

E-locker Update

Bicycle & Active
Transportation Advisory
Committee

September 16, 2022



E-lockers in the Corridor



- 324 spaces
- 22 stations

Zone 1



Zone 2



Zone 3



Zone 4



Overall Use - Unique Cards

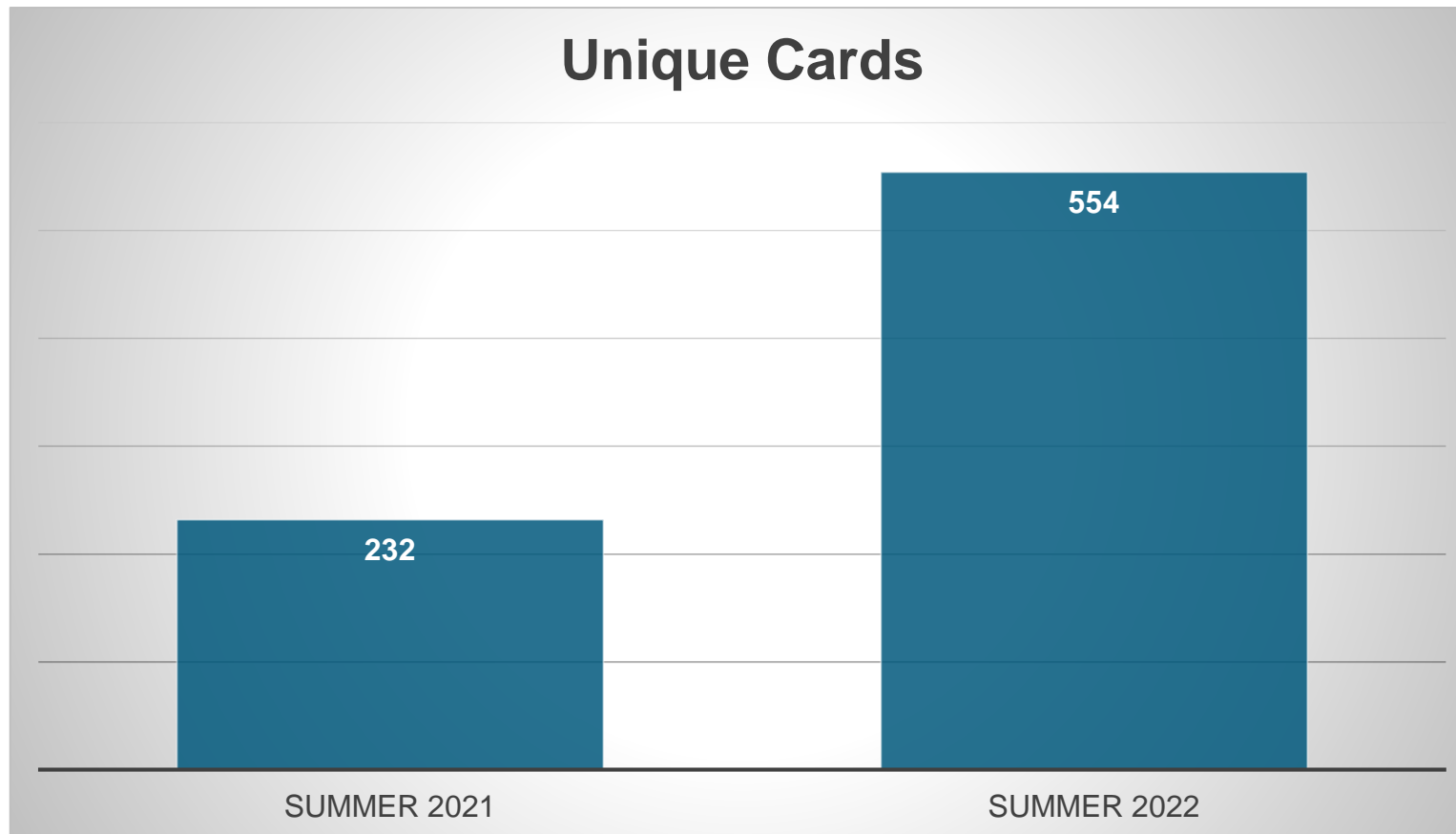

- Compares June 13 to September 13 in 2021 vs. 2022

Overall Use – Weekday Rentals

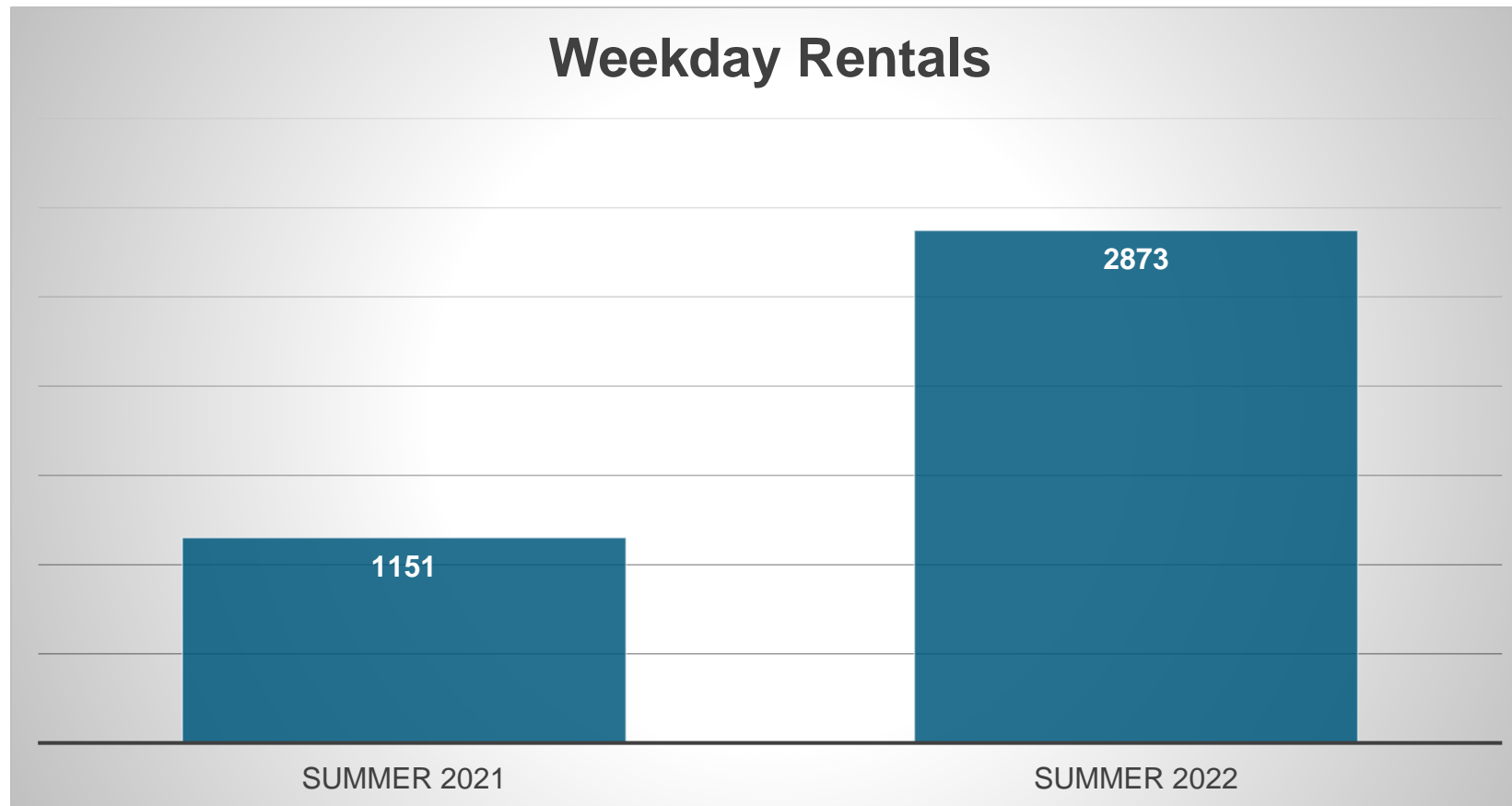

- Compares June 13 to September 13 in 2021 vs. 2022

Overall Use – Weekend Rentals

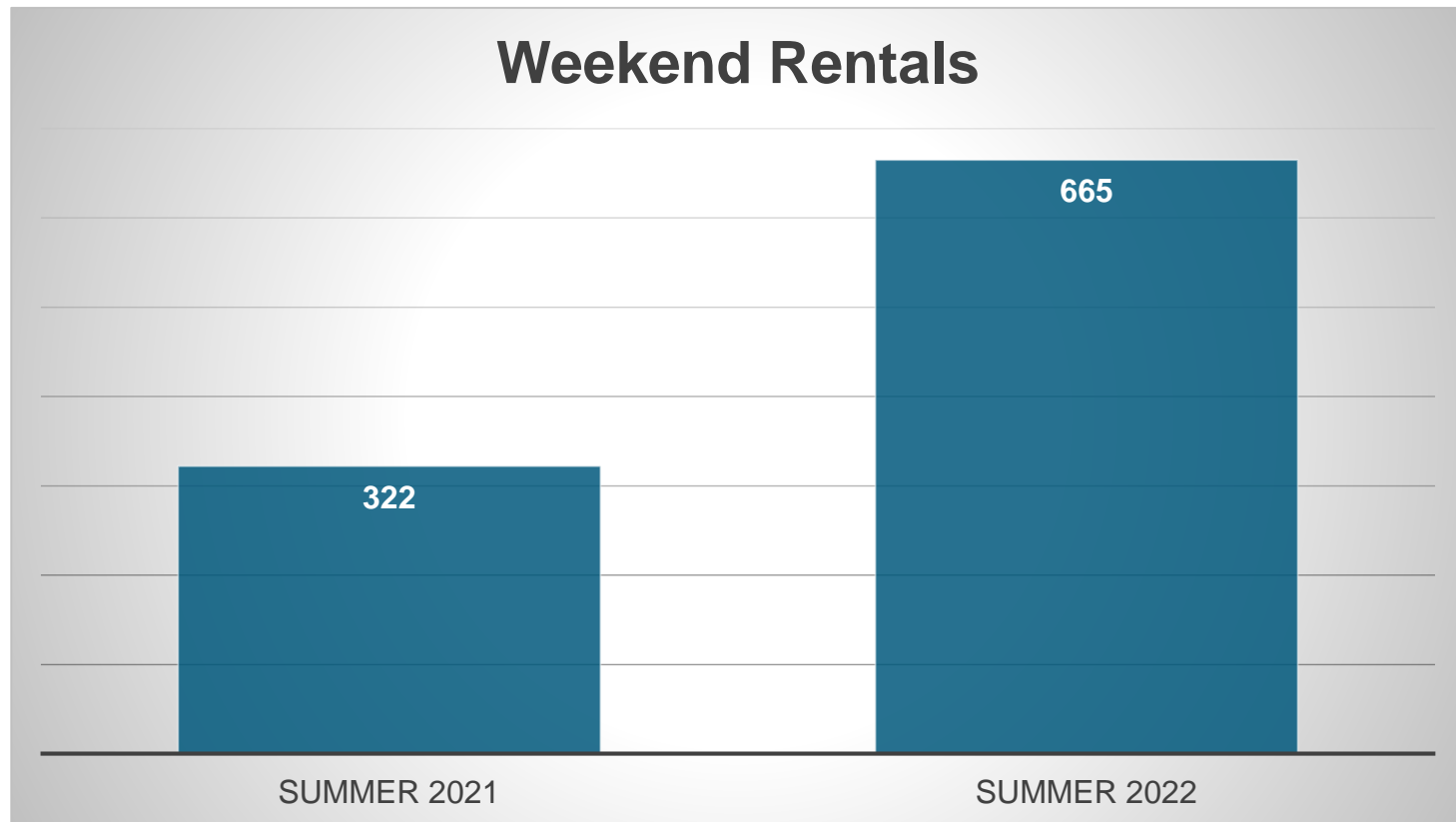

- Compares June 13 to September 13 in 2021 vs. 2022

Overall Use – Total Rentals

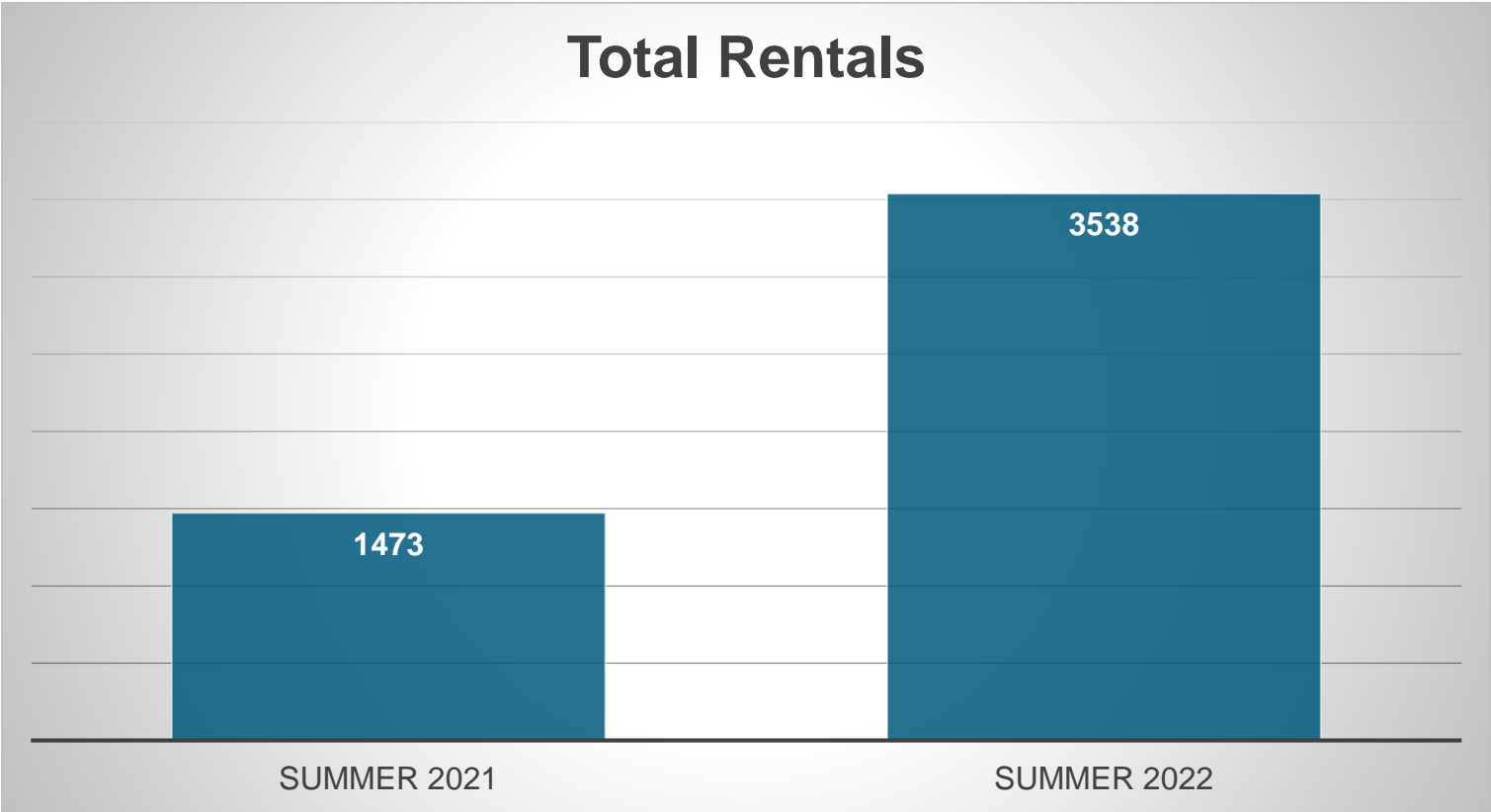

- Compares June 13 to September 13 in 2021 vs. 2022



Customers by Station

Unique Cards

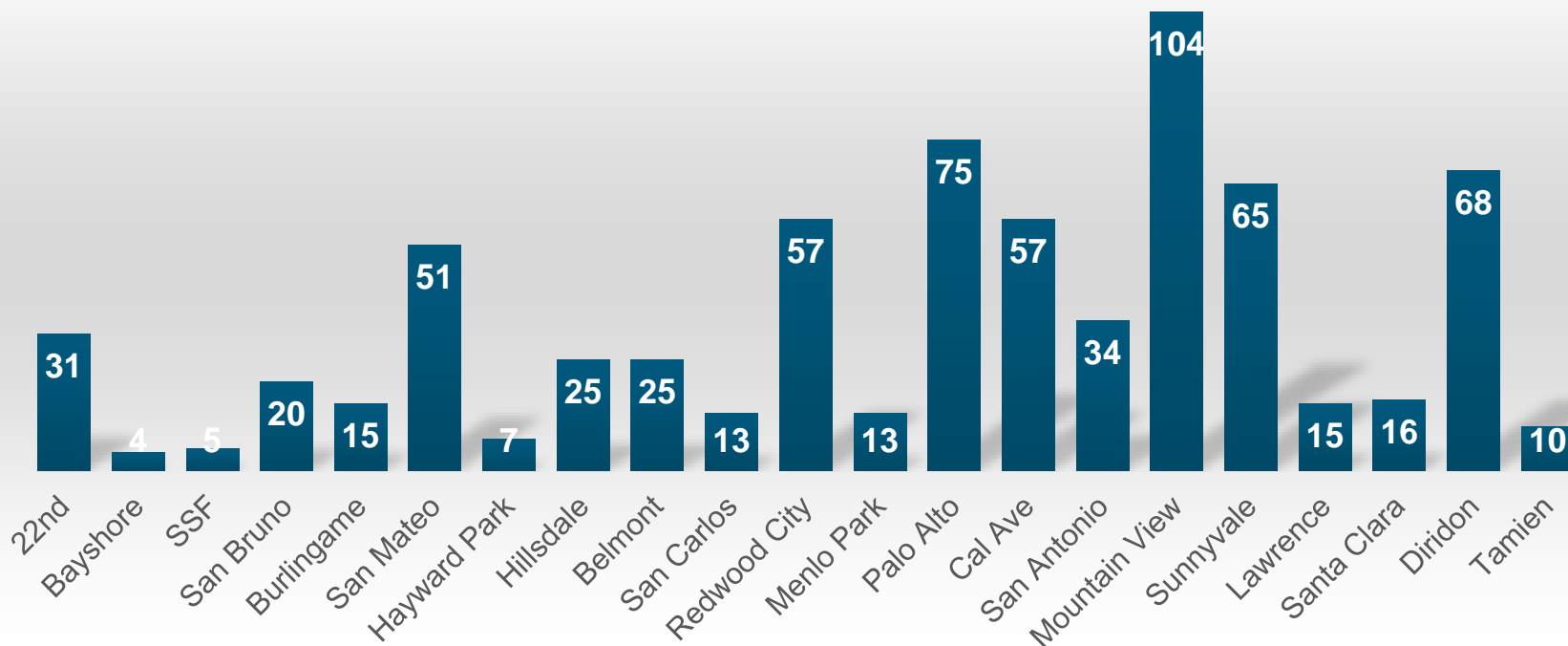

- Mid-June 2022 – mid-September 2022
- Millbrae data not available
- About 150 of 554 customers used more than 1 station

Weekday Rentals by Station

Weekday Rentals

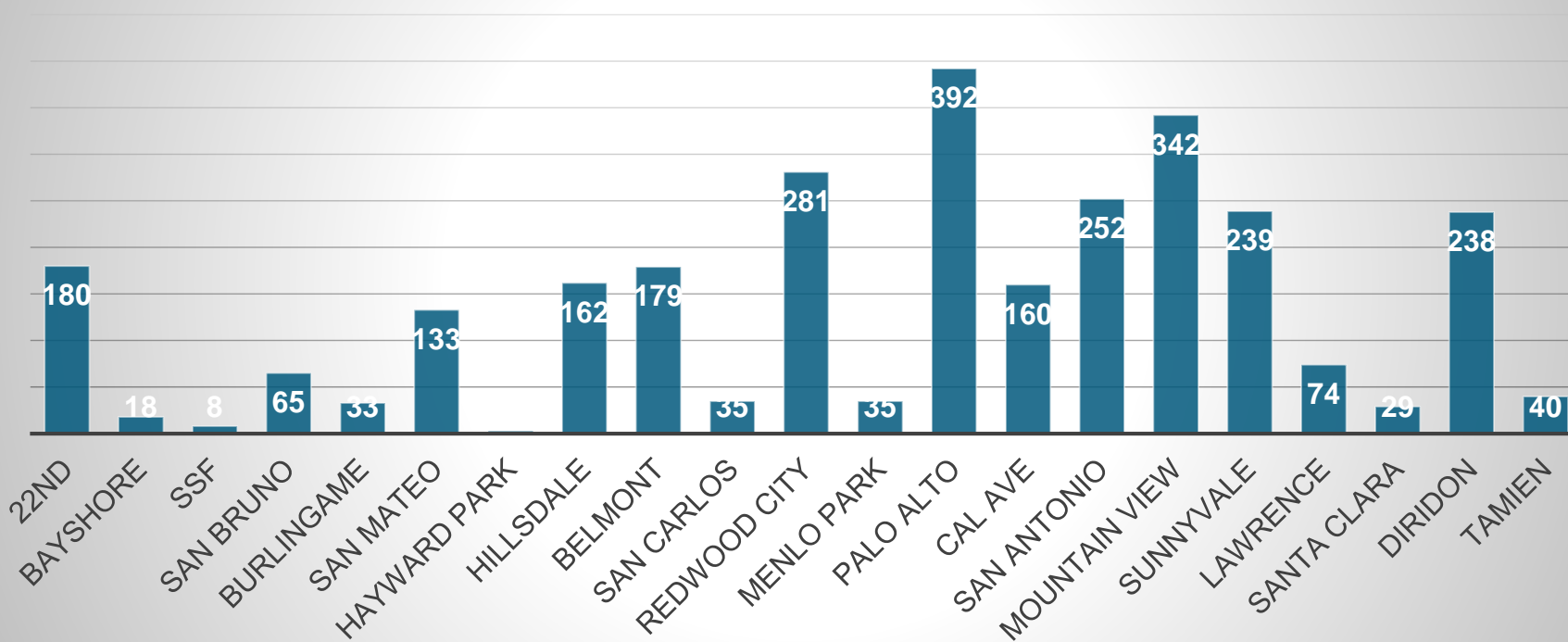

- Mid-June 2022 – mid-September 2022
- Millbrae data not available

Weekend Rentals by Station

Weekend Rentals

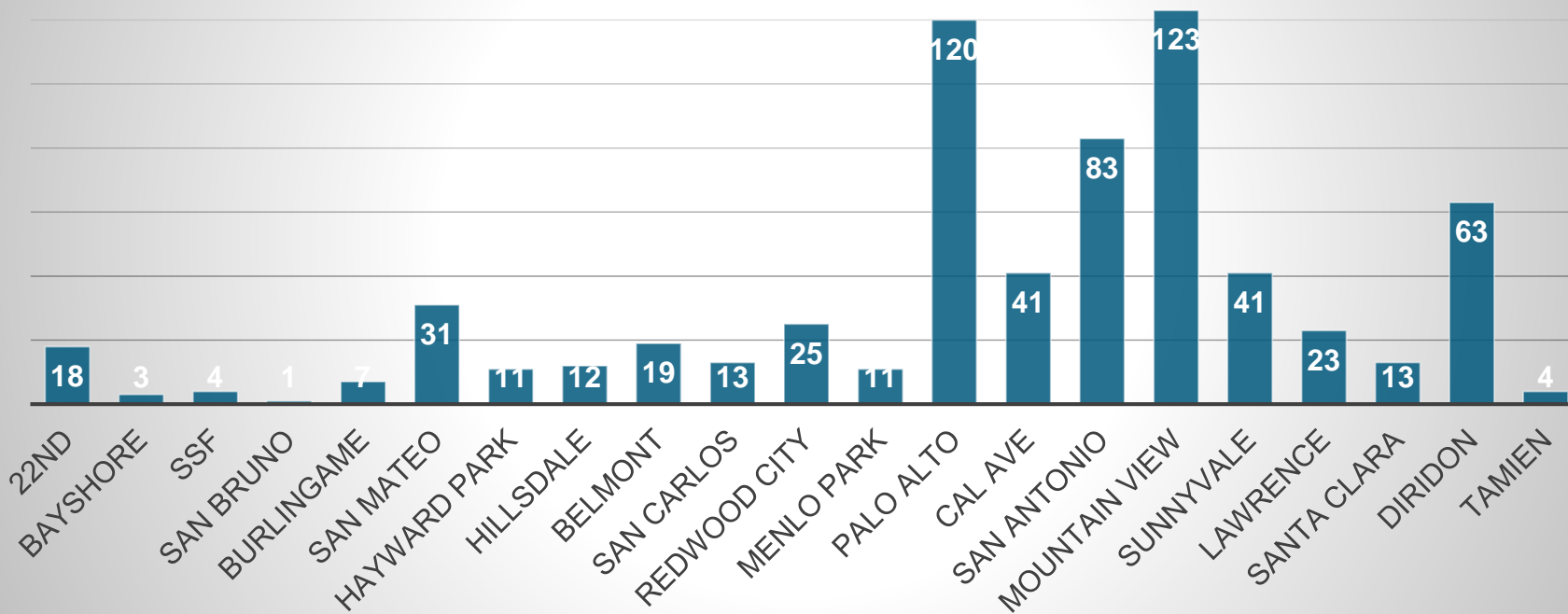

- Mid-June 2022 – mid-September 2022
- Millbrae data not available

Total Rentals by Station

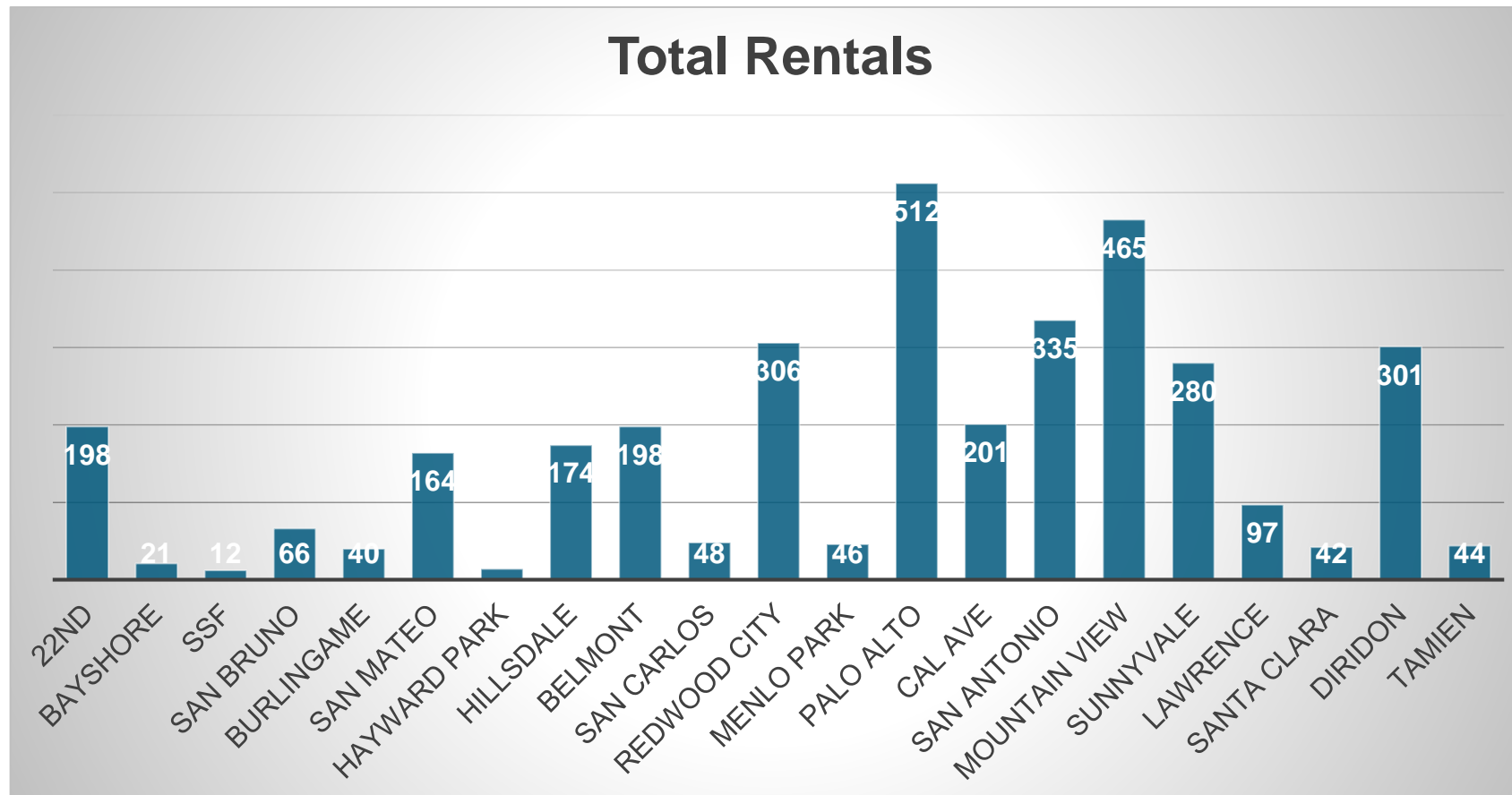

- Mid-June 2022 – mid-September 2022
- Millbrae data not available

Repeat Customers

- Highest average rentals per card:
 - San Antonio (9.9)
 - Belmont (7.9)
 - Hillsdale (7.0)
- Lowest average rentals per card:
 - Hayward Park (2.0)
 - South San Francisco (2.4)
 - Burlingame (2.7)
- Mid-June 2022 – mid-September 2022
- Millbrae data not available

Method of Rental Starts

All Time Rental Starts

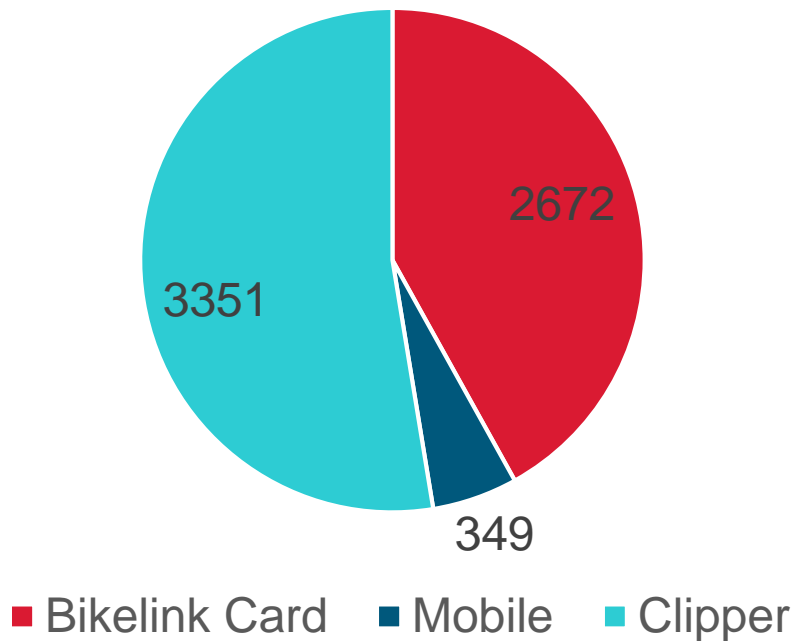

- Highest percentage Clipper starts:
 - Bayshore (88%), SSF (82%), Burlingame (76%)
- Lowest percentage Clipper starts
 - San Antonio (19%), San Bruno (28%), Tamien & Menlo Park (40%)

Contract Modification

- Costs of sheet metal increased significantly
- Vendor costs are up 40+%
- Working to revise contract

Bike Link App



- App is available
- Stickers for e-lockers ordered
- Promotion of app coming

G-7 Model

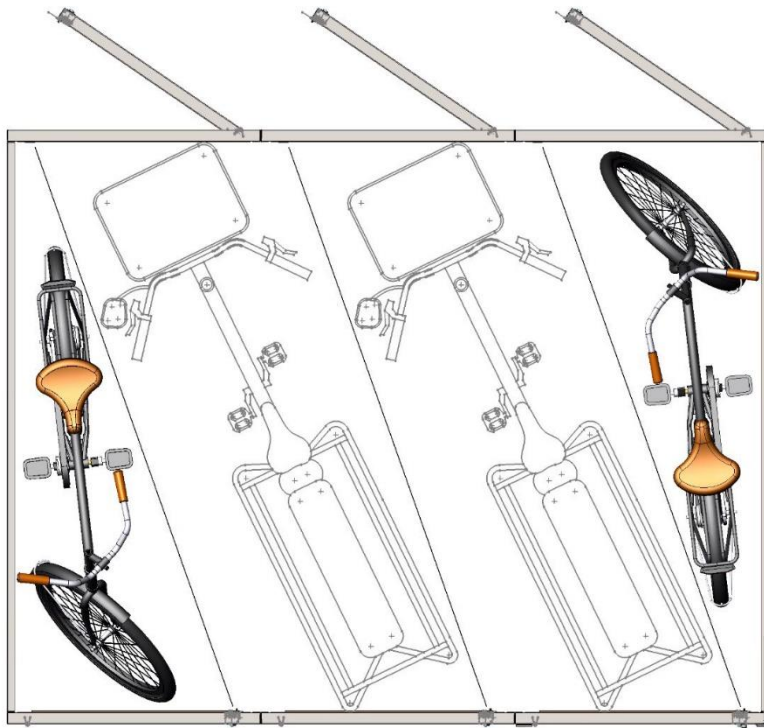

- Being assembled in Berkeley
- Includes option for cargo bikes
- Allows for future 2nd level
- Installations planned:
 - Hillsdale
 - Palo Alto
 - Cal Ave
 - San Antonio
 - Diridon

Questions

