

E-locker Update

Bicycle & Active
Transportation Advisory
Committee

September 15, 2022



E-lockers & Biking in the Corridor

- 324 spaces at 22 stations
- 21% of Caltrain customers use a bike as part of their trip*
 - Most take it on board (19% of all customers)
 - The rest (2% of all customers) leave a bike at a station
- *2022 Customer Satisfaction Survey of over 2,000 people



Zone 1



Zone 2



Zone 3



Zone 4



Overall Use - Unique Cards

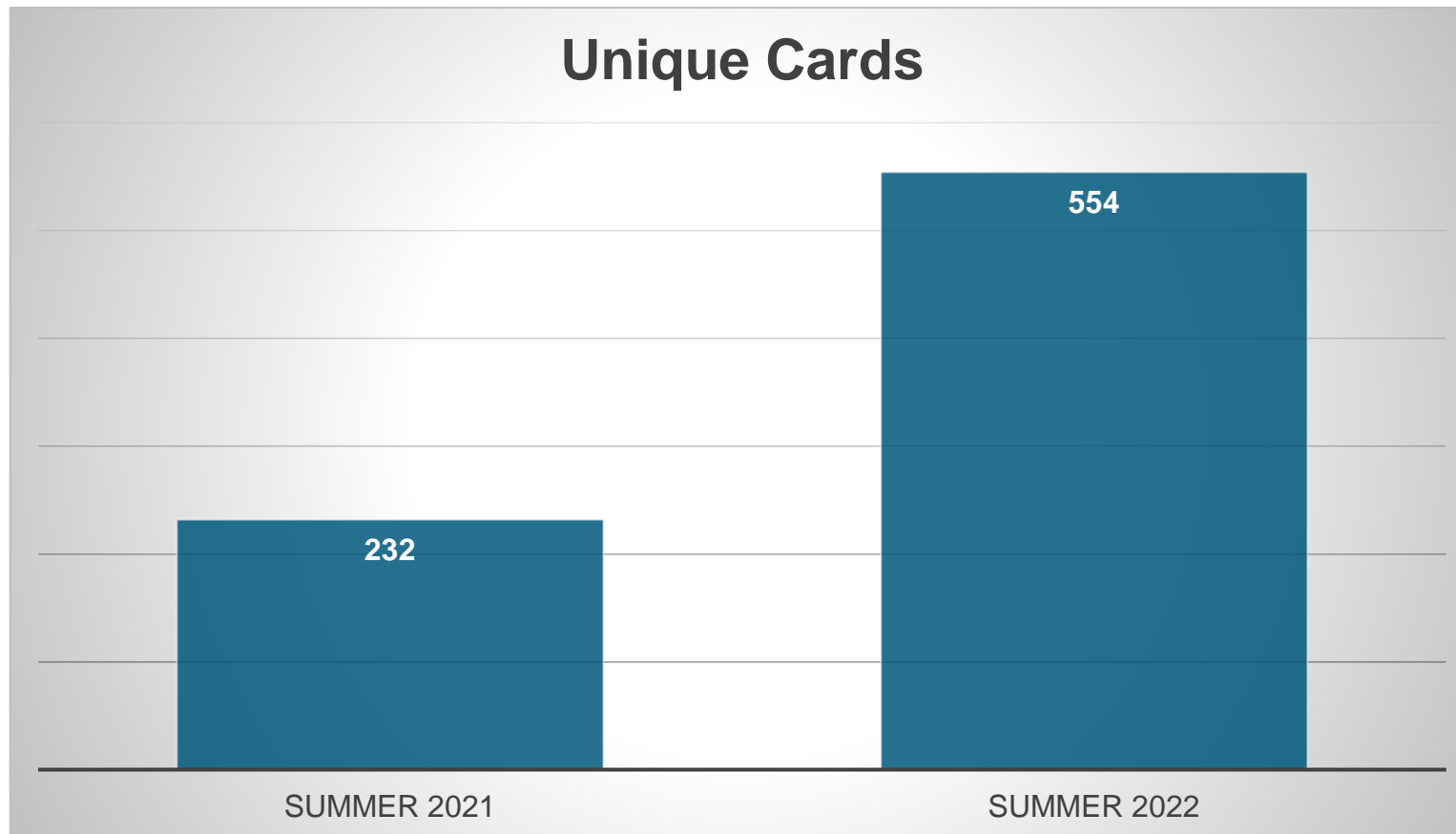

- Compares June 13 to September 13 in 2021 vs. 2022

Overall Use – Weekday Rentals

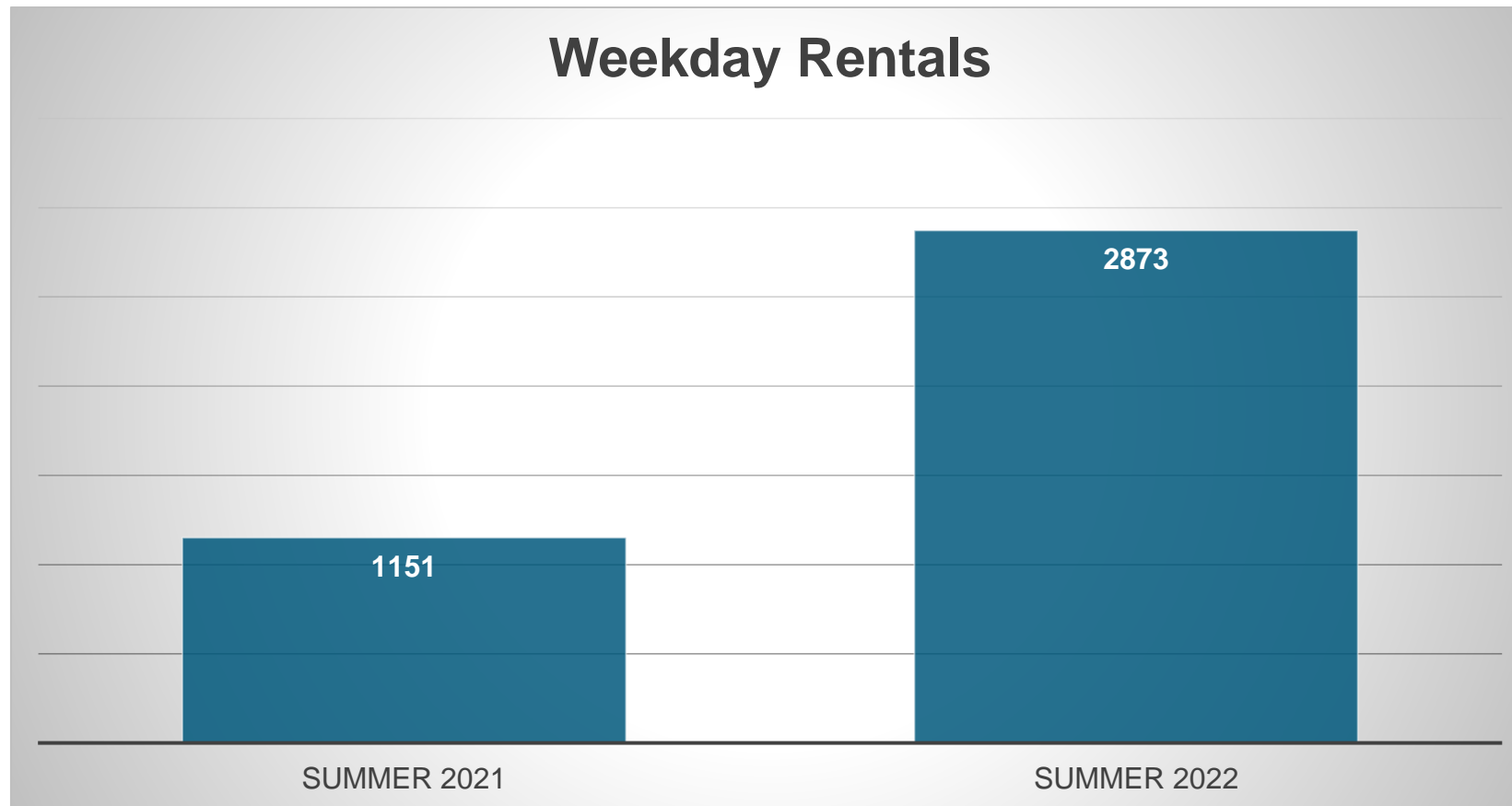

- Compares June 13 to September 13 in 2021 vs. 2022

Overall Use – Weekend Rentals

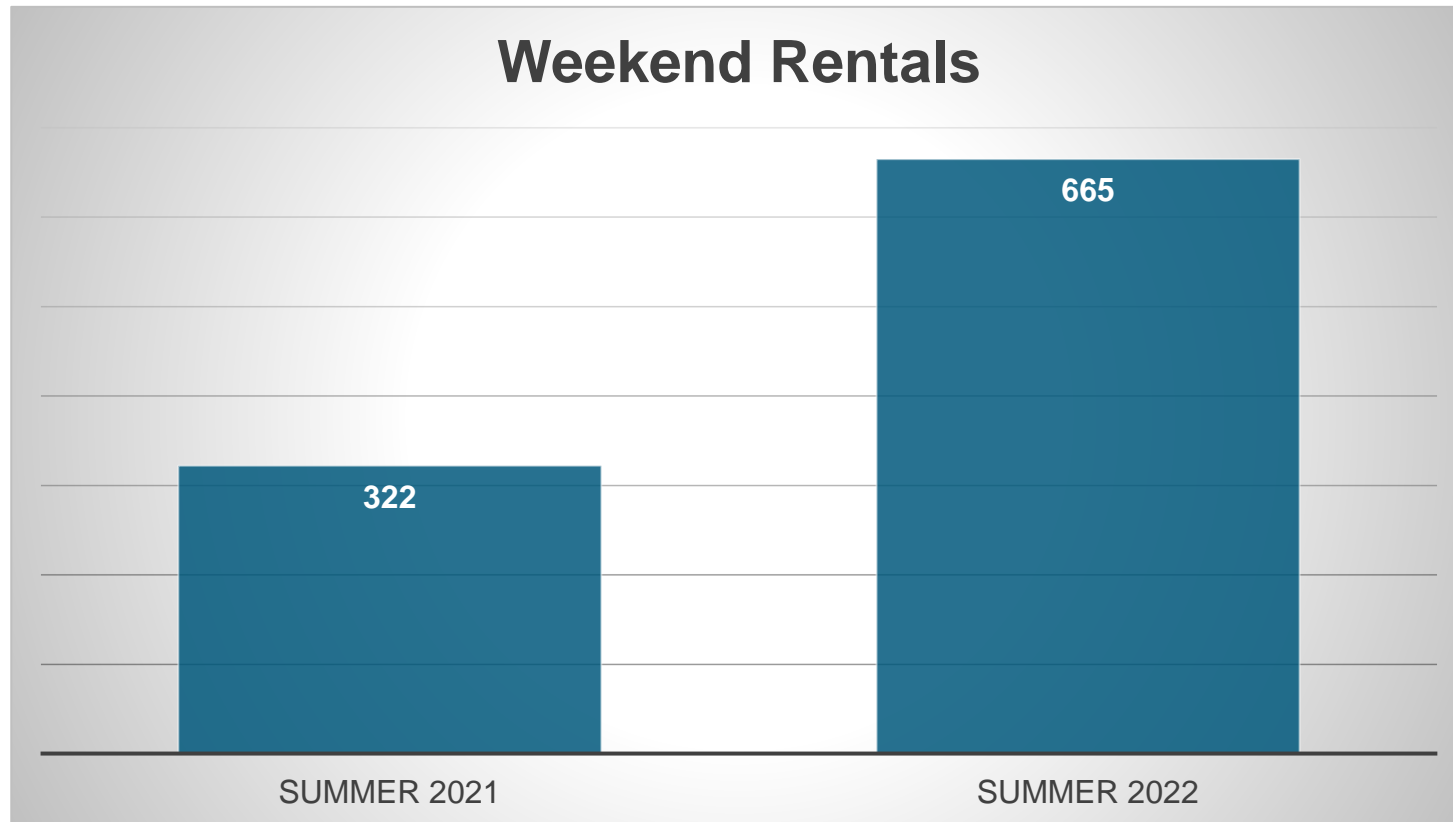

- Compares June 13 to September 13 in 2021 vs. 2022

Overall Use – Total Rentals

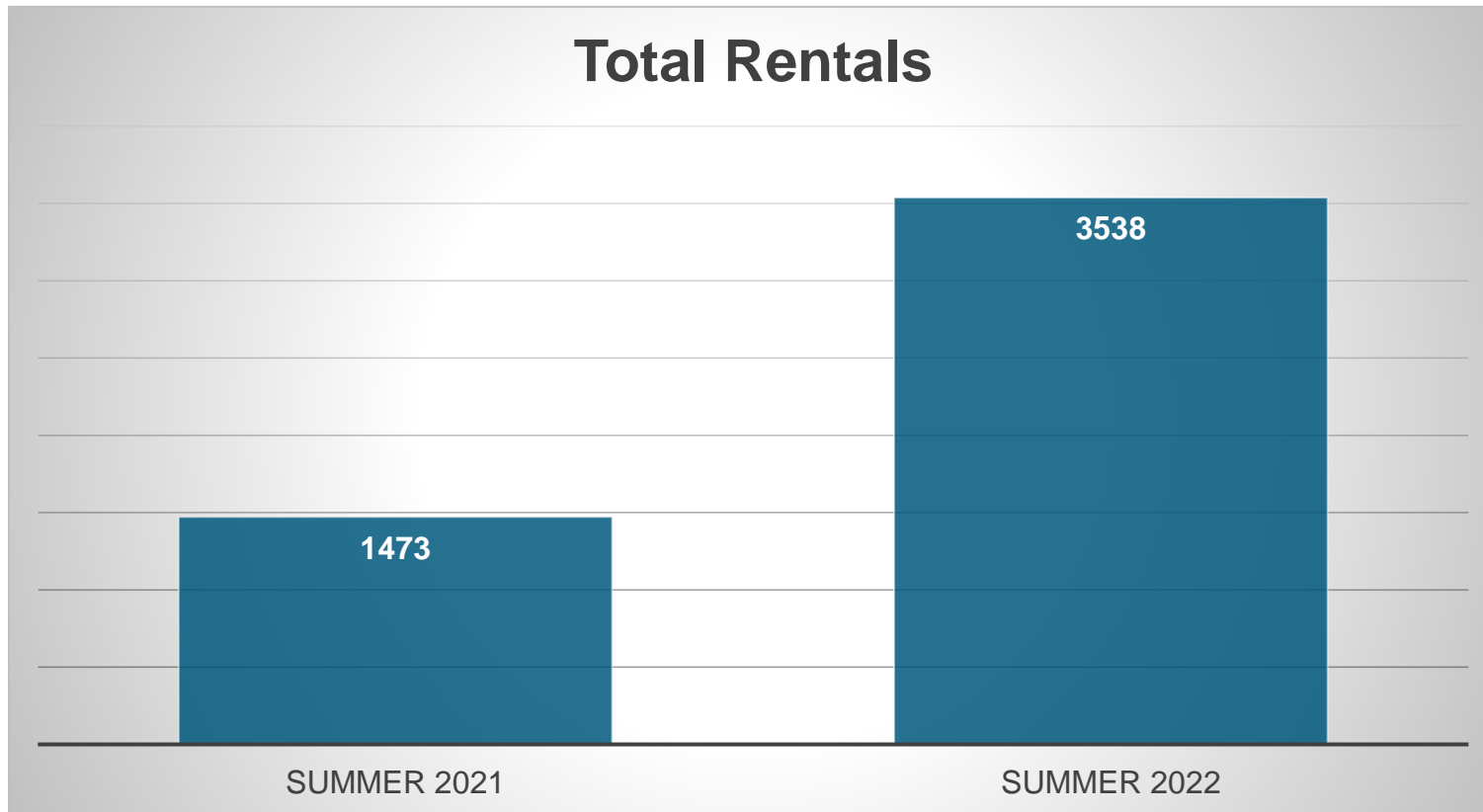

- Compares June 13 to September 13 in 2021 vs. 2022

Customers by Station – Summer 2022

Unique Cards

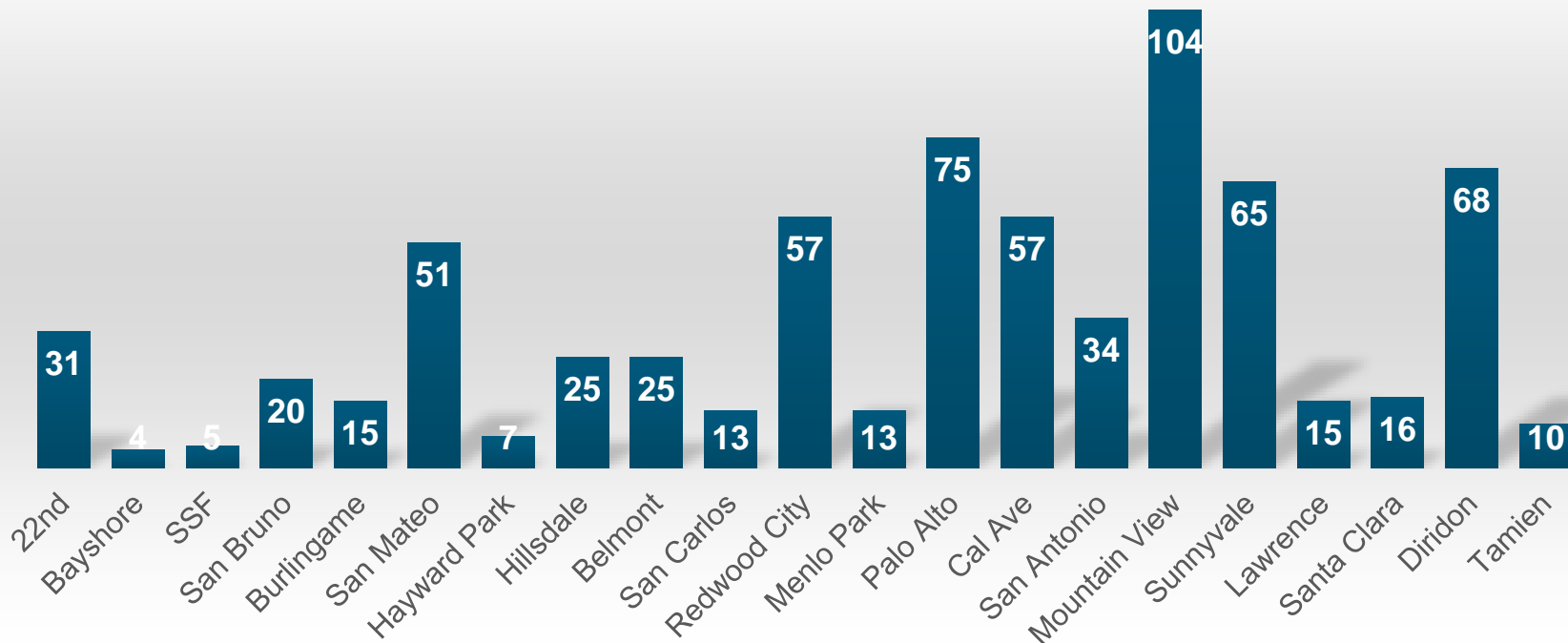

- Mid-June 2022 – mid-September 2022
- Millbrae data not available
- About 150 of 554 customers used more than 1 station

Weekday Rentals by Station – Summer 2022

Weekday Rentals

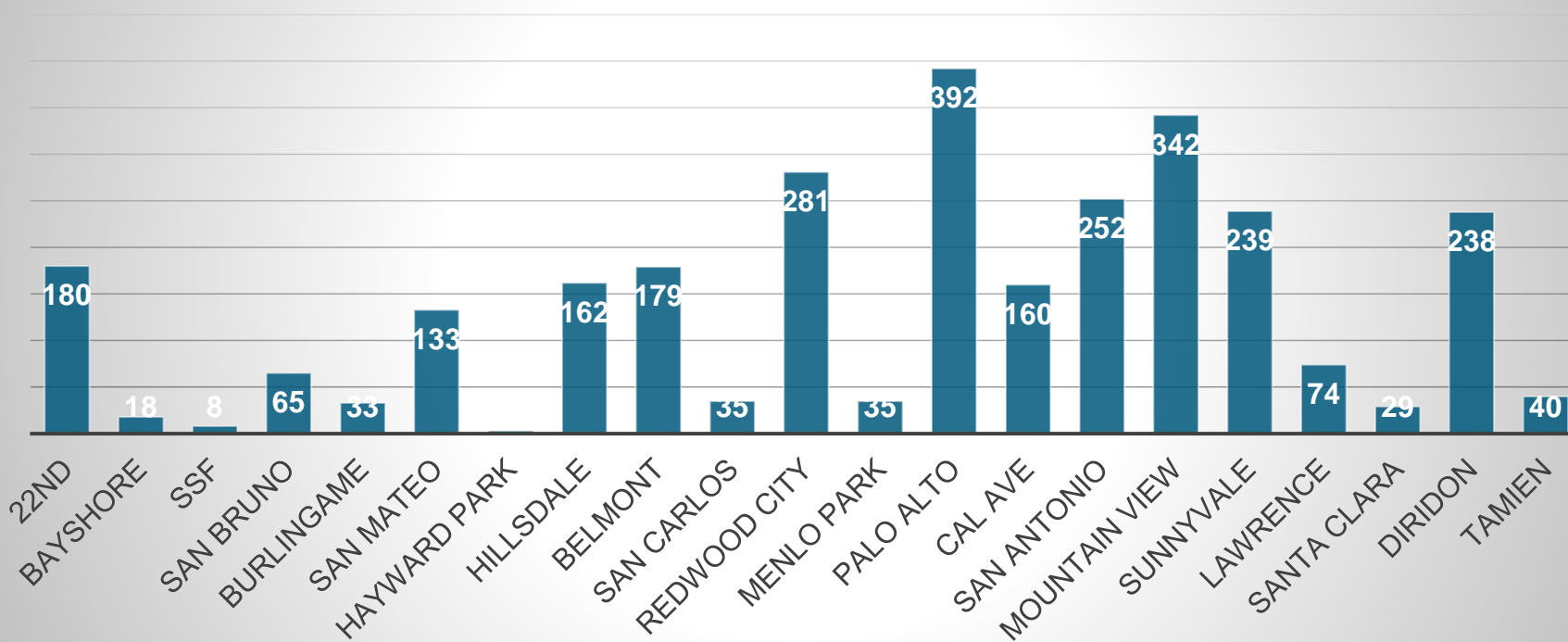

- Mid-June 2022 – mid-September 2022
- Millbrae data not available

Weekend Rentals by Station – Summer 2022

Weekend Rentals

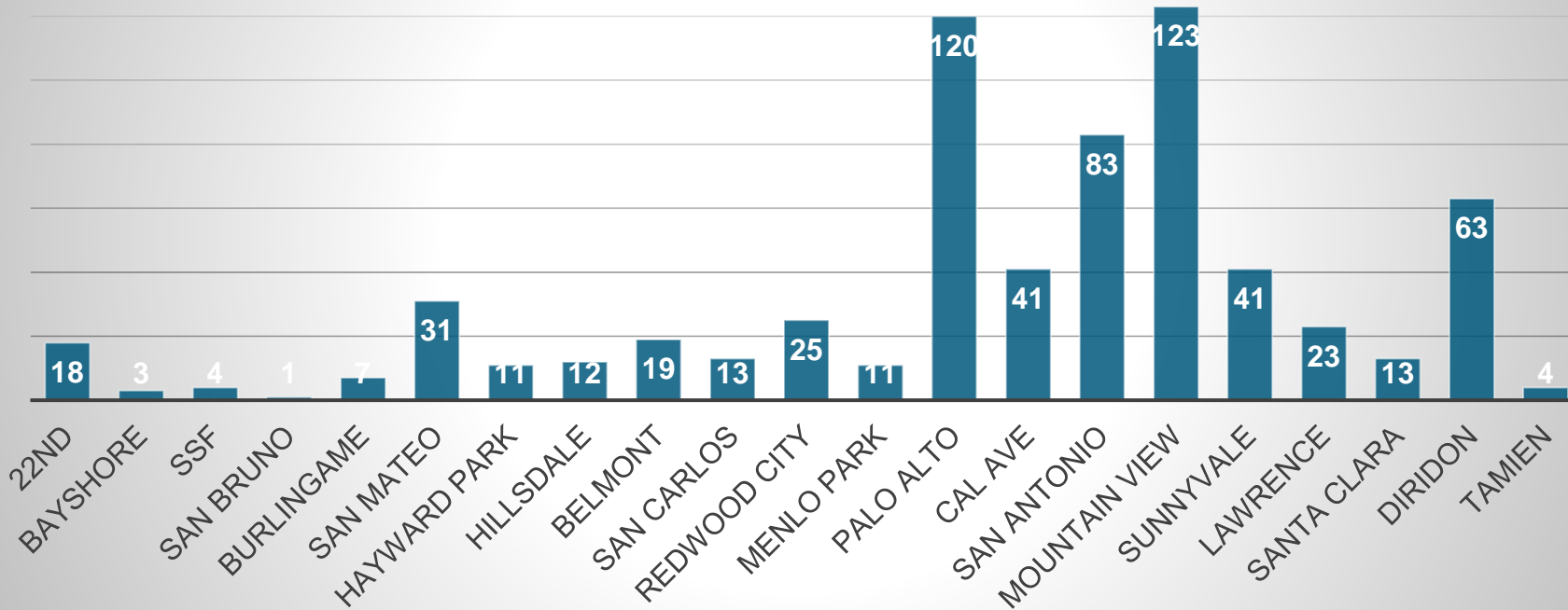

- Mid-June 2022 – mid-September 2022
- Millbrae data not available

Total Rentals by Station – Summer 2022

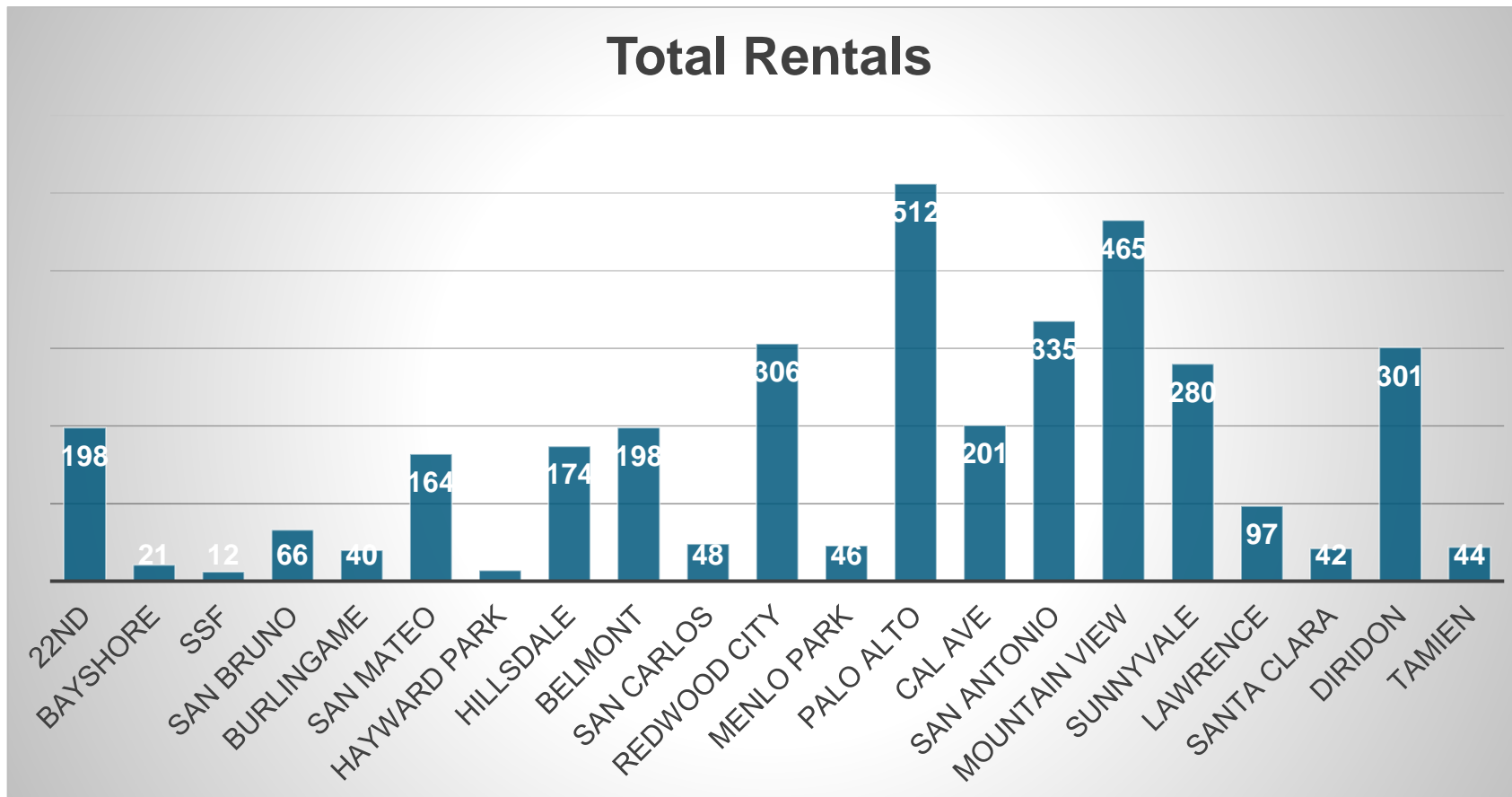

- Mid-June 2022 – mid-September 2022
- Millbrae data not available

Repeat Customers – Summer 2022

- Highest average rentals per card:
 - San Antonio (9.9)
 - Belmont (7.9)
 - Hillsdale (7.0)
- Lowest average rentals per card:
 - Hayward Park (2.0)
 - South San Francisco (2.4)
 - Burlingame (2.7)
- Mid-June 2022 – mid-September 2022
- Millbrae data not available

Overall Use

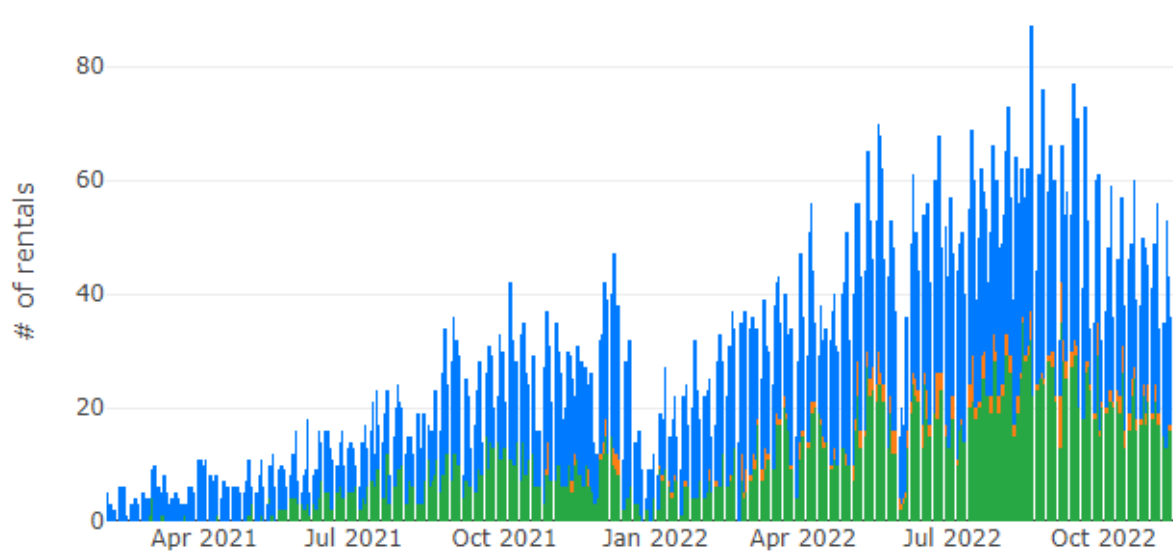

- 16250 rentals started
- 1359 unique cards

App Clipper Bike Link Card

Contract Modification

- Costs of sheet metal increased significantly
- Vendor costs are up 40+%
- Working to revise contract

Bike Link App



- App is available
- Stickers for e-lockers ordered
- Promotion of app coming

G-7 Model

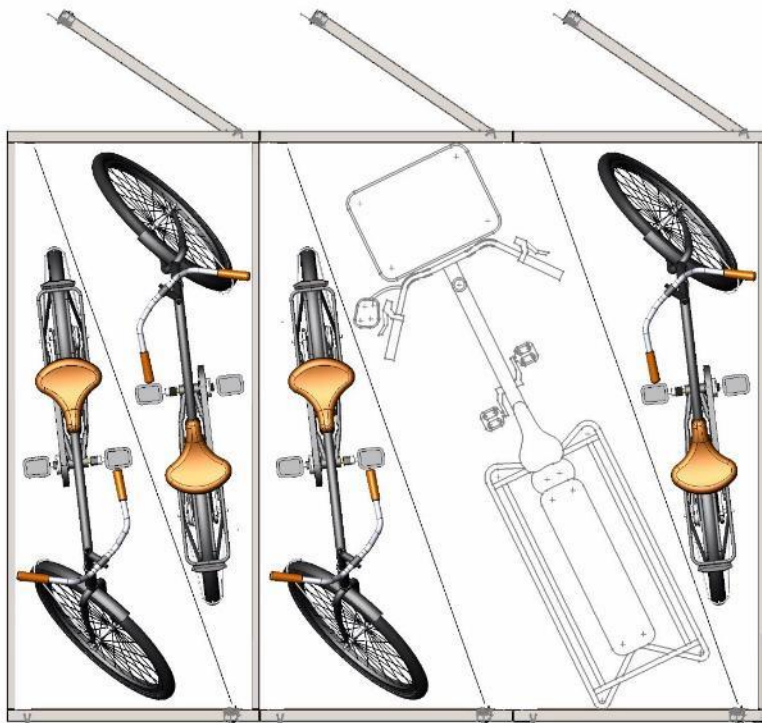

- Being assembled in Berkeley
- Includes option for cargo bikes
- Allows for future 2nd level
- Installations planned:
 - Hillsdale
 - Palo Alto
 - Cal Ave
 - San Antonio
 - Diridon

Questions

