

ATTACHMENT G
SYNCHRO/SIMTRAFFIC OUTPUT SHEETS



Existing Conditions



Intersection Pennsylvania Street/22nd Street

Unsignalized

Direction	Movement	Volume (veh/hr)			GEH	Total Delay (sec/veh)		
		Demand	Served	% Served		Average	Std. Dev.	LOS
NB	Left Turn	52	52	99.2%	0.1	7.7	0.6	A
	Through	162	159	98.4%	0.2	8.1	0.4	A
	Right Turn	57	59	104.0%	0.3	6.1	0.7	A
	Subtotal	271	270	99.7%	0.0	7.6	0.3	A
SB	Left Turn	26	27	103.1%	0.2	6.3	0.7	A
	Through	70	70	99.6%	0.0	6.8	0.5	A
	Right Turn	10	10	100.0%	0.0	3.7	0.4	A
	Subtotal	106	107	100.5%	0.0	6.4	0.5	A
EB	Left Turn	6	5	86.7%	0.3	4.8	0.6	A
	Through	21	21	101.0%	0.0	6.2	0.7	A
	Right Turn	64	65	101.7%	0.1	3.9	0.4	A
	Subtotal	91	92	100.5%	0.1	4.5	0.3	A
WB	Left Turn	61	56	91.8%	0.7	5.5	0.4	A
	Through	21	26	121.4%	0.9	5.4	0.6	A
	Right Turn	16	16	101.9%	0.1	4.1	0.6	A
	Subtotal	98	98	99.8%	0.0	5.2	0.2	A
Total		566	566	100.0%	0.0	6.5	0.2	A

Intersection Indiana Street/22nd Street

Unsignalized

Direction	Movement	Volume (veh/hr)			GEH	Total Delay (sec/veh)		
		Demand	Served	% Served		Average	Std. Dev.	LOS
NB	Left Turn	13	14	103.8%	0.1	5.0	0.6	A
	Through	58	53	90.5%	0.7	6.3	0.5	A
	Right Turn	44	45	101.1%	0.1	4.2	0.5	A
	Subtotal	115	111	96.1%	0.4	5.3	0.4	A
SB	Left Turn	3	3	83.3%	0.3	5.1	2.2	A
	Through	17	18	103.5%	0.1	5.5	0.6	A
	Right Turn	11	9	82.7%	0.6	3.2	0.4	A
	Subtotal	31	29	94.2%	0.3	4.7	0.4	A
EB	Left Turn	18	18	100.6%	0.0	4.8	0.5	A
	Through	79	83	105.2%	0.5	5.2	0.3	A
	Right Turn	15	16	105.3%	0.2	3.6	0.4	A
	Subtotal	112	117	104.5%	0.5	4.9	0.2	A
WB	Left Turn	7	5	74.3%	0.7	4.1	0.4	A
	Through	71	70	97.9%	0.2	4.9	0.2	A
	Right Turn	6	10	158.3%	1.3	3.3	0.5	A
	Subtotal	84	84	100.2%	0.0	4.7	0.2	A
Total		342	341	99.7%	0.1	5.0	0.1	A

SimTraffic Post-Processor
Average Results from 20 Runs
Volume and Delay by Movement

Caltrain Electrification
Existing Conditions
AM Peak Hour

Intersection

Tunnel Avenue/Blanken Avenue

Unsignalized

Direction	Movement	Volume (veh/hr)			GEH	Total Delay (sec/veh)		
		Demand	Served	% Served		Average	Std. Dev.	LOS
NB	Left Turn	41	39	95.9%	0.3	7.4	0.6	A
	Through	118	121	102.5%	0.3	8.4	0.5	A
	Right Turn	15	15	101.3%	0.1	5.5	0.8	A
	Subtotal	174	176	100.9%	0.1	7.9	0.4	A
SB	Left Turn	56	50	88.4%	0.9	6.0	0.5	A
	Through	98	103	105.2%	0.5	7.2	0.3	A
	Right Turn	7	8	108.6%	0.2	4.0	1.0	A
	Subtotal	161	160	99.5%	0.1	6.7	0.3	A
EB	Left Turn	10	10	100.0%	0.0	8.2	1.9	A
	Through	143	145	101.3%	0.2	9.5	0.7	A
	Right Turn	181	184	101.8%	0.2	6.5	0.7	A
	Subtotal	334	339	101.5%	0.3	7.9	0.6	A
WB	Left Turn	17	17	100.6%	0.0	7.0	1.2	A
	Through	72	75	104.6%	0.4	7.6	0.5	A
	Right Turn	67	65	96.7%	0.3	4.3	0.5	A
	Subtotal	156	157	100.8%	0.1	6.2	0.5	A
Total		825	832	100.8%	0.2	7.3	0.4	A

SimTraffic Post-Processor
Average Results from 20 Runs
Volume and Delay by Movement

Caltrain Electrification
Existing Conditions
AM Peak Hour

Intersection

Dubuque Avenue/Grand Avenue

Signalized

Direction	Movement	Volume (veh/hr)			GEH	Total Delay (sec/veh)		
		Demand	Served	% Served		Average	Std. Dev.	LOS
NB	Left Turn							
	Through							
	Right Turn							
	Subtotal							
SB	Left Turn	26	24	90.4%	0.5	48.0	7.8	D
	Through							
	Right Turn	42	40	95.0%	0.3	9.1	0.6	A
	Subtotal	68	63	93.2%	0.6	23.3	2.4	C
EB	Left Turn	39	37	94.6%	0.3	60.2	6.0	E
	Through	647	638	98.7%	0.3	4.3	0.6	A
	Right Turn							
	Subtotal	686	675	98.4%	0.4	7.3	0.6	A
WB	Left Turn							
	Through	524	526	100.3%	0.1	6.0	0.7	A
	Right Turn	35	36	102.9%	0.2	4.2	1.0	A
	Subtotal	559	562	100.4%	0.1	5.9	0.6	A
Total		1313	1300	99.0%	0.4	7.5	0.5	A

SimTraffic Post-Processor
Average Results from 20 Runs
Volume and Delay by Movement

Caltrain Electrification
Existing Conditions
AM Peak Hour

Intersection

Linden Avenue-San Mateo Avenue/San Mateo Avenue

Signalized

Direction	Movement	Volume (veh/hr)			GEH	Total Delay (sec/veh)		
		Demand	Served	% Served		Average	Std. Dev.	LOS
NB	Left Turn							
	Through	74	74	100.5%	0.0	5.5	0.9	A
	Right Turn	196	192	98.1%	0.3	1.2	0.1	A
	Subtotal	270	267	98.7%	0.2	2.4	0.3	A
SB	Left Turn	124	121	97.4%	0.3	12.6	0.8	B
	Through	100	103	102.9%	0.3	2.1	0.8	A
	Right Turn							
	Subtotal	224	224	99.9%	0.0	7.8	0.6	A
EB	Left Turn							
	Through							
	Right Turn							
	Subtotal							
WB	Left Turn	163	164	100.4%	0.1	12.8	0.6	B
	Through							
	Right Turn	82	84	101.8%	0.2	6.0	0.1	A
	Subtotal	245	247	100.9%	0.1	10.5	0.5	B
Total		739	738	99.8%	0.1	6.7	0.3	A

Intersection

Herman Street/Scott Street

Unsignalized

Direction	Movement	Volume (veh/hr)			GEH	Total Delay (sec/veh)		
		Demand	Served	% Served		Average	Std. Dev.	LOS
NB	Left Turn							
	Through	108	109	100.6%	0.1	11.5	1.8	B
	Right Turn	129	122	94.6%	0.6	8.3	2.3	A
	Subtotal	237	231	97.3%	0.4	9.8	1.9	A
SB	Left Turn	33	32	97.6%	0.1	9.7	1.4	A
	Through	93	96	103.3%	0.3	9.5	0.7	A
	Right Turn	2	1	60.0%	0.6	4.3	3.6	A
	Subtotal	128	130	101.2%	0.1	9.5	0.8	A
EB	Left Turn							
	Through	23	24	104.8%	0.2	9.1	1.6	A
	Right Turn	5	5	104.0%	0.1	4.4	1.5	A
	Subtotal	28	29	104.6%	0.2	8.3	1.5	A
WB	Left Turn	50	56	111.4%	0.8	0.2	0.1	A
	Through	7	10	135.7%	0.9	0.4	0.3	A
	Right Turn	50	50	99.6%	0.0	0.2	0.1	A
	Subtotal	107	115	107.5%	0.8	0.2	0.1	A
Total		500	505	100.9%	0.2	7.4	1.1	A

SimTraffic Post-Processor
Average Results from 20 Runs
Volume and Delay by Movement

Caltrain Electrification
Existing Conditions
AM Peak Hour

Intersection **Montgomery Avenue/Scott Street**

Unsignalized

Direction	Movement	Volume (veh/hr)			GEH	Total Delay (sec/veh)		
		Demand	Served	% Served		Average	Std. Dev.	LOS
NB	Left Turn	13	15	115.4%	0.5	5.7	1.2	A
	Through	3	1	46.7%	1.1	4.5	3.4	A
	Right Turn	9	11	118.9%	0.5	3.1	0.7	A
	Subtotal	25	27	108.4%	0.4	4.8	1.0	A
SB	Left Turn	6	6	100.0%	0.0	4.5	0.9	A
	Through	2	3	145.0%	0.6	5.5	2.7	A
	Right Turn	11	13	119.1%	0.6	3.4	0.7	A
	Subtotal	19	22	115.8%	0.7	4.0	0.8	A
EB	Left Turn	31	30	96.5%	0.2	2.0	0.2	A
	Through	133	129	96.8%	0.4	0.6	0.1	A
	Right Turn	21	20	95.7%	0.2	0.3	0.1	A
	Subtotal	185	179	96.6%	0.5	0.8	0.1	A
WB	Left Turn	8	9	107.5%	0.2	1.9	0.7	A
	Through	83	88	105.4%	0.5	0.2	0.1	A
	Right Turn	3	3	93.3%	0.1	0.2	0.3	A
	Subtotal	94	99	105.2%	0.5	0.4	0.1	A
Total		323	327	101.2%	0.2	1.2	0.1	A

Intersection **Driveway-Dollar Avenue/Linden Avenue**

Signalized

Direction	Movement	Volume (veh/hr)			GEH	Total Delay (sec/veh)		
		Demand	Served	% Served		Average	Std. Dev.	LOS
NB	Left Turn	64	65	101.4%	0.1	22.7	1.5	C
	Through							
	Right Turn	58	56	96.9%	0.2	16.4	2.6	B
	Subtotal	122	121	99.3%	0.1	19.8	1.6	B
SB	Left Turn	2	2	95.0%	0.1	26.8	16.8	C
	Through							
	Right Turn							
	Subtotal	2	2	95.0%	0.1	26.8	16.8	C
EB	Left Turn							
	Through	164	166	101.0%	0.1	24.3	2.1	C
	Right Turn	67	67	100.4%	0.0	14.7	2.8	B
	Subtotal	231	233	100.8%	0.1	21.5	2.0	C
WB	Left Turn	39	38	97.2%	0.2	1.6	1.0	A
	Through	117	118	100.9%	0.1	1.6	0.5	A
	Right Turn							
	Subtotal	156	156	99.9%	0.0	1.6	0.4	A
Total		511	512	100.2%	0.0	15.1	1.4	B

SimTraffic Post-Processor
Average Results from 20 Runs
Volume and Delay by Movement

Caltrain Electrification
Existing Conditions
AM Peak Hour

Intersection

San Mateo Avenue/San Bruno Avenue

Signalized

Direction	Movement	Volume (veh/hr)			GEH	Total Delay (sec/veh)		
		Demand	Served	% Served		Average	Std. Dev.	LOS
NB	Left Turn	7	7	100.0%	0.0	22.0	4.8	C
	Through	74	71	95.7%	0.4	18.1	2.3	B
	Right Turn	153	154	100.3%	0.0	8.4	0.3	A
	Subtotal	234	231	98.8%	0.2	11.8	0.8	B
SB	Left Turn	51	50	97.6%	0.2	23.0	3.0	C
	Through	26	28	108.1%	0.4	19.6	4.7	B
	Right Turn	33	34	104.2%	0.2	10.1	2.9	B
	Subtotal	110	112	102.1%	0.2	18.4	2.7	B
EB	Left Turn	2	1	70.0%	0.5	6.1	8.1	A
	Through	368	382	103.8%	0.7	3.4	0.3	A
	Right Turn							
	Subtotal	370	384	103.6%	0.7	3.4	0.3	A
WB	Left Turn	77	72	93.2%	0.6	23.0	2.4	C
	Through	271	260	95.8%	0.7	15.1	0.9	B
	Right Turn	105	102	97.0%	0.3	9.2	1.5	A
	Subtotal	453	433	95.6%	0.9	15.0	0.9	B
Total		1167	1160	99.4%	0.2	10.9	0.5	B

SimTraffic Post-Processor
Average Results from 20 Runs
Volume and Delay by Movement

Caltrain Electrification
Existing Conditions
AM Peak Hour

Intersection

El Camino Real/Millbrae Avenue

Signalized

Direction	Movement	Volume (veh/hr)			GEH	Total Delay (sec/veh)		
		Demand	Served	% Served		Average	Std. Dev.	LOS
NB	Left Turn	22	23	106.4%	0.3	75.3	15.2	E
	Through	354	351	99.2%	0.2	40.1	1.7	D
	Right Turn	549	545	99.3%	0.2	5.0	0.6	A
	Subtotal	925	920	99.4%	0.2	20.1	0.8	C
SB	Left Turn	668	659	98.7%	0.3	84.6	10.0	F
	Through	700	699	99.9%	0.0	30.4	2.0	C
	Right Turn	32	32	100.9%	0.1	31.6	4.9	C
	Subtotal	1400	1391	99.3%	0.3	56.1	5.9	E
EB	Left Turn	58	56	97.1%	0.2	85.6	5.9	F
	Through	642	650	101.2%	0.3	53.5	4.8	D
	Right Turn	20	24	120.0%	0.9	50.2	8.7	D
	Subtotal	720	730	101.4%	0.4	55.8	4.7	E
WB	Left Turn	424	432	102.0%	0.4	71.1	6.2	E
	Through	212	232	109.5%	1.3	34.6	2.6	C
	Right Turn	483	478	99.0%	0.2	11.1	0.7	B
	Subtotal	1119	1143	102.1%	0.7	38.5	2.4	D
Total		4164	4183	100.5%	0.3	43.4	1.9	D

Intersection

Rollins Road/Millbrae Avenue

Signalized

Direction	Movement	Volume (veh/hr)			GEH	Total Delay (sec/veh)		
		Demand	Served	% Served		Average	Std. Dev.	LOS
NB	Left Turn	116	118	101.4%	0.1	43.7	2.2	D
	Through	113	111	98.6%	0.2	48.3	4.2	D
	Right Turn	246	245	99.6%	0.1	20.6	1.6	C
	Subtotal	475	474	99.8%	0.0	32.8	1.2	C
SB	Left Turn	131	127	97.1%	0.3	38.9	1.2	D
	Through	17	17	99.4%	0.0	39.8	5.6	D
	Right Turn	20	22	110.0%	0.4	6.4	2.2	A
	Subtotal	168	166	98.9%	0.1	34.6	1.4	C
EB	Left Turn	286	278	97.2%	0.5	71.6	11.1	E
	Through	1300	1310	100.8%	0.3	30.0	1.4	C
	Right Turn	273	275	100.6%	0.1	18.5	1.1	B
	Subtotal	1859	1863	100.2%	0.1	34.5	1.9	C
WB	Left Turn	436	441	101.1%	0.2	53.9	3.6	D
	Through	983	1002	101.9%	0.6	29.8	1.7	C
	Right Turn	413	421	101.9%	0.4	11.6	1.6	B
	Subtotal	1832	1864	101.7%	0.7	31.4	1.9	C
Total		4334	4366	100.7%	0.5	33.0	0.9	C

Intersection **California Drive/Oak Grove Avenue**

Signalized

Direction	Movement	Volume (veh/hr)			GEH	Total Delay (sec/veh)		
		Demand	Served	% Served		Average	Std. Dev.	LOS
NB	Left Turn	21	18	87.6%	0.6	54.3	10.2	D
	Through	472	487	103.2%	0.7	28.2	1.1	C
	Right Turn	223	217	97.4%	0.4	8.6	1.2	A
	Subtotal	716	723	100.9%	0.3	23.0	0.8	C
SB	Left Turn	56	55	98.8%	0.1	57.7	3.7	E
	Through	622	631	101.5%	0.4	25.2	1.7	C
	Right Turn	29	32	108.6%	0.5	11.9	1.8	B
	Subtotal	707	718	101.5%	0.4	27.1	1.8	C
EB	Left Turn	38	39	101.8%	0.1	76.6	22.1	E
	Through	301	314	104.2%	0.7	76.4	17.2	E
	Right Turn	22	22	97.7%	0.1	70.7	26.4	E
	Subtotal	361	374	103.5%	0.7	76.0	17.9	E
WB	Left Turn	155	151	97.1%	0.4	30.2	1.6	C
	Through	95	97	101.7%	0.2	30.8	3.7	C
	Right Turn	88	84	95.8%	0.4	19.3	3.2	B
	Subtotal	338	331	98.0%	0.4	27.6	1.9	C
Total		2122	2146	101.1%	0.5	34.3	3.7	C

Intersection **Carolan Avenue/Oak Grove Avenue**

Unsignalized

Direction	Movement	Volume (veh/hr)			GEH	Total Delay (sec/veh)		
		Demand	Served	% Served		Average	Std. Dev.	LOS
NB	Left Turn	43	48	110.7%	0.7	98.2	36.2	F
	Through	92	91	98.6%	0.1	82.8	33.4	F
	Right Turn	37	34	92.2%	0.5	85.2	40.5	F
	Subtotal	172	172	100.2%	0.0	87.1	34.4	F
SB	Left Turn	4	5	122.5%	0.4	46.0	43.1	E
	Through	106	108	101.7%	0.2	31.6	6.6	D
	Right Turn	169	164	97.3%	0.4	38.8	11.8	E
	Subtotal	279	277	99.3%	0.1	36.1	7.2	E
EB	Left Turn	378	371	98.2%	0.4	0.5	0.1	A
	Through	120	135	112.8%	1.4	1.1	0.2	A
	Right Turn	82	84	102.2%	0.2	0.2	0.1	A
	Subtotal	580	590	101.8%	0.4	0.6	0.1	A
WB	Left Turn	17	16	92.4%	0.3	135.9	71.5	F
	Through	126	119	94.2%	0.7	146.9	62.4	F
	Right Turn	16	16	102.5%	0.1	124.0	68.3	F
	Subtotal	159	151	94.8%	0.7	142.9	62.8	F
Total		1190	1191	100.0%	0.0	39.6	12.4	E

Intersection **California Drive/North Lane**

Unsignalized

Direction	Movement	Volume (veh/hr)			GEH	Total Delay (sec/veh)		
		Demand	Served	% Served		Average	Std. Dev.	LOS
NB	Left Turn							
	Through	667	673	100.8%	0.2	1.3	0.1	A
	Right Turn	169	164	97.3%	0.4	3.0	0.5	A
	Subtotal	836	837	100.1%	0.0	1.7	0.1	A
SB	Left Turn	114	118	103.8%	0.4	30.6	5.7	D
	Through	620	616	99.4%	0.2	4.0	0.6	A
	Right Turn							
	Subtotal	734	734	100.1%	0.0	8.3	1.4	A
EB	Left Turn							
	Through							
	Right Turn							
	Subtotal							
WB	Left Turn	46	47	101.1%	0.1	36.5	6.4	E
	Through							
	Right Turn	105	105	99.5%	0.0	4.9	0.6	A
	Subtotal	151	151	100.0%	0.0	14.7	2.7	B
Total		1721	1722	100.1%	0.0	5.6	0.6	A

Intersection **Carolan Avenue/North Lane**

Unsignalized

Direction	Movement	Volume (veh/hr)			GEH	Total Delay (sec/veh)		
		Demand	Served	% Served		Average	Std. Dev.	LOS
NB	Left Turn	70	71	101.6%	0.1	42.2	18.8	E
	Through	125	124	99.1%	0.1	13.2	3.8	B
	Right Turn	12	12	96.7%	0.1	6.5	2.7	A
	Subtotal	207	207	99.8%	0.0	23.0	9.3	C
SB	Left Turn	3	4	116.7%	0.3	14.1	12.1	B
	Through	116	114	97.8%	0.2	20.4	3.7	C
	Right Turn	81	81	99.8%	0.0	21.8	11.2	C
	Subtotal	200	198	98.9%	0.2	20.9	6.1	C
EB	Left Turn	186	185	99.4%	0.1	0.7	0.1	A
	Through	12	14	115.0%	0.5	0.7	0.3	A
	Right Turn	85	86	101.2%	0.1	0.4	0.1	A
	Subtotal	283	285	100.6%	0.1	0.6	0.1	A
WB	Left Turn							
	Through							
	Right Turn							
	Subtotal							
Total		690	689	99.9%	0.0	13.2	4.5	B

Intersection Anita Road/Peninsula Avenue

Unsignalized

Direction	Movement	Volume (veh/hr)			GEH	Total Delay (sec/veh)		
		Demand	Served	% Served		Average	Std. Dev.	LOS
NB	Left Turn							
	Through							
	Right Turn							
	Subtotal							
SB	Left Turn	20	20	98.5%	0.1	16.4	6.6	C
	Through							
	Right Turn	20	20	97.5%	0.1	14.9	7.4	B
	Subtotal	40	39	98.0%	0.1	15.6	6.9	C
EB	Left Turn	40	41	103.3%	0.2	7.4	1.8	A
	Through	557	573	102.9%	0.7	0.6	0.2	A
	Right Turn							
	Subtotal	597	614	102.9%	0.7	1.1	0.3	A
WB	Left Turn							
	Through	521	532	102.0%	0.5	5.0	0.6	A
	Right Turn	60	62	103.5%	0.3	4.0	1.3	A
	Subtotal	581	594	102.2%	0.5	4.9	0.6	A
Total		1218	1247	102.4%	0.8	3.4	0.5	A

Intersection Woodside Way/Villa Terrace

Unsignalized

Direction	Movement	Volume (veh/hr)			GEH	Total Delay (sec/veh)		
		Demand	Served	% Served		Average	Std. Dev.	LOS
NB	Left Turn	6	6	105.0%	0.1	4.5	0.6	A
	Through	25	27	106.8%	0.3	5.6	0.3	A
	Right Turn	3	3	110.0%	0.2	2.4	0.3	A
	Subtotal	34	36	106.8%	0.4	5.1	0.3	A
SB	Left Turn	6	4	73.3%	0.7	5.3	0.9	A
	Through	18	21	115.0%	0.6	6.1	0.7	A
	Right Turn	53	50	93.6%	0.5	3.1	0.2	A
	Subtotal	77	75	97.0%	0.3	4.1	0.4	A
EB	Left Turn	40	40	100.8%	0.0	1.9	0.1	A
	Through	16	17	108.1%	0.3	0.7	0.6	A
	Right Turn	6	7	116.7%	0.4	0.2	0.3	A
	Subtotal	62	65	104.2%	0.3	1.4	0.2	A
WB	Left Turn							
	Through	14	15	110.0%	0.4	0.4	0.3	A
	Right Turn	17	19	113.5%	0.5	0.2	0.1	A
	Subtotal	31	35	111.9%	0.6	0.2	0.1	A
Total		204	210	103.1%	0.4	2.8	0.2	A

SimTraffic Post-Processor
Average Results from 20 Runs
Volume and Delay by Movement

Caltrain Electrification
Existing Conditions
AM Peak Hour

Intersection N. San Mateo Drive/Villa Terrace

Unsignalized

Direction	Movement	Volume (veh/hr)			GEH	Total Delay (sec/veh)		
		Demand	Served	% Served		Average	Std. Dev.	LOS
NB	Left Turn	15	14	96.0%	0.2	4.3	1.1	A
	Through	422	420	99.4%	0.1	0.5	0.1	A
	Right Turn	32	34	107.2%	0.4	0.6	0.2	A
	Subtotal	469	468	99.8%	0.0	0.6	0.1	A
SB	Left Turn	10	10	96.0%	0.1	5.6	1.1	A
	Through	498	500	100.5%	0.1	2.2	0.1	A
	Right Turn	14	15	108.6%	0.3	2.2	0.3	A
	Subtotal	522	525	100.6%	0.1	2.2	0.1	A
EB	Left Turn	9	9	101.1%	0.0	12.2	3.6	B
	Through	20	21	103.0%	0.1	13.8	2.9	B
	Right Turn	12	11	87.5%	0.4	5.8	2.3	A
	Subtotal	41	40	98.0%	0.1	11.7	2.0	B
WB	Left Turn	34	31	91.5%	0.5	9.1	1.2	A
	Through	20	21	102.5%	0.1	11.0	1.5	B
	Right Turn	19	21	110.5%	0.4	4.8	0.8	A
	Subtotal	73	73	99.5%	0.0	8.4	0.7	A
Total		1105	1106	100.1%	0.0	2.3	0.1	A

Intersection Arundel Road/Peninsula Avenue

Unsignalized

Direction	Movement	Volume (veh/hr)			GEH	Total Delay (sec/veh)		
		Demand	Served	% Served		Average	Std. Dev.	LOS
NB	Left Turn	24	25	102.5%	0.1	22.2	5.6	C
	Through	8	10	126.3%	0.7	18.7	8.2	C
	Right Turn	50	53	105.8%	0.4	9.8	1.6	A
	Subtotal	82	88	106.8%	0.6	14.3	2.3	B
SB	Left Turn	14	14	98.6%	0.1	13.2	3.7	B
	Through	9	9	100.0%	0.0	18.5	7.5	C
	Right Turn	6	6	101.7%	0.0	9.2	5.2	A
	Subtotal	29	29	99.7%	0.0	14.3	2.3	B
EB	Left Turn	8	7	87.5%	0.4	4.6	1.9	A
	Through	534	554	103.8%	0.9	0.5	0.1	A
	Right Turn	35	33	95.1%	0.3	0.5	0.2	A
	Subtotal	577	595	103.0%	0.7	0.5	0.1	A
WB	Left Turn	33	29	89.1%	0.6	5.1	0.8	A
	Through	551	546	99.0%	0.2	2.4	0.6	A
	Right Turn	22	20	89.5%	0.5	1.3	0.4	A
	Subtotal	606	595	98.1%	0.5	2.5	0.5	A
Total		1294	1306	100.9%	0.3	2.7	0.3	A

Intersection **Railroad Ave/1st Ave**

Unsignalized

Direction	Movement	Volume (veh/hr)			GEH	Total Delay (sec/veh)		
		Demand	Served	% Served		Average	Std. Dev.	LOS
NB	Left Turn	2	1	60.0%	0.6	12.4	12.6	B
	Through	4	5	122.5%	0.4	9.0	5.0	A
	Right Turn	3	5	150.0%	0.8	5.4	1.1	A
	Subtotal	9	11	117.8%	0.5	8.8	3.6	A
SB	Left Turn							
	Through							
	Right Turn							
	Subtotal							
EB	Left Turn	10	10	98.0%	0.1	2.0	1.0	A
	Through	43	46	106.5%	0.4	0.3	0.1	A
	Right Turn							
	Subtotal	53	56	104.9%	0.4	0.6	0.2	A
WB	Left Turn							
	Through	128	130	101.3%	0.1	10.6	2.3	B
	Right Turn	6	7	111.7%	0.3	6.7	4.9	A
	Subtotal	134	136	101.7%	0.2	10.4	2.4	B
Total		196	203	103.3%	0.5	7.7	1.7	A

Intersection **S. B. St/1st Ave**

Signalized

Direction	Movement	Volume (veh/hr)			GEH	Total Delay (sec/veh)		
		Demand	Served	% Served		Average	Std. Dev.	LOS
NB	Left Turn	15	16	108.7%	0.3	34.8	9.6	C
	Through	145	148	102.3%	0.3	13.2	2.7	B
	Right Turn	19	18	96.3%	0.2	11.4	6.9	B
	Subtotal	179	183	102.2%	0.3	14.9	2.9	B
SB	Left Turn	31	29	92.9%	0.4	24.4	9.4	C
	Through	107	111	104.0%	0.4	12.9	4.9	B
	Right Turn	5	5	90.0%	0.2	6.7	5.9	A
	Subtotal	143	145	101.1%	0.1	14.9	5.0	B
EB	Left Turn	2	2	85.0%	0.2	71.7	55.2	E
	Through	19	20	103.2%	0.1	66.8	10.6	E
	Right Turn	19	17	90.5%	0.4	20.1	11.1	C
	Subtotal	40	39	96.3%	0.2	47.7	11.4	D
WB	Left Turn	10	11	106.0%	0.2	53.3	15.3	D
	Through	36	36	100.3%	0.0	49.7	5.2	D
	Right Turn	58	55	94.8%	0.4	27.2	6.1	C
	Subtotal	104	102	97.8%	0.2	38.1	5.2	D
Total		466	468	100.4%	0.1	22.6	1.1	C

SimTraffic Post-Processor
Average Results from 20 Runs
Volume and Delay by Movement

Caltrain Electrification
Existing Conditions
AM Peak Hour

Intersection Transit Center Way/1st St

Unsignalized

Direction	Movement	Volume (veh/hr)			GEH	Total Delay (sec/veh)		
		Demand	Served	% Served		Average	Std. Dev.	LOS
NB	Left Turn	8	8	103.8%	0.1	6.7	5.8	A
	Through							
	Right Turn	5	7	130.0%	0.6	3.5	3.4	A
	Subtotal	13	15	113.8%	0.5	5.1	3.3	A
SB	Left Turn							
	Through							
	Right Turn							
	Subtotal							
EB	Left Turn	15	13	84.7%	0.6	3.0	0.7	A
	Through	48	50	104.2%	0.3	1.8	1.0	A
	Right Turn	6	6	96.7%	0.1	0.9	1.1	A
	Subtotal	69	69	99.3%	0.1	1.9	0.8	A
WB	Left Turn							
	Through	96	95	98.4%	0.2	1.7	0.9	A
	Right Turn	34	37	109.7%	0.6	0.3	0.4	A
	Subtotal	130	132	101.4%	0.2	1.4	0.8	A
Total		212	215	101.5%	0.2	1.8	0.7	A

SimTraffic Post-Processor
Average Results from 20 Runs
Volume and Delay by Movement

Caltrain Electrification
Existing Conditions
AM Peak Hour

Intersection **Railroad Avenue/9th Avenue**

Unsignalized

Direction	Movement	Volume (veh/hr)			GEH	Total Delay (sec/veh)		
		Demand	Served	% Served		Average	Std. Dev.	LOS
NB	Left Turn	24	25	102.9%	0.1	42.5	24.4	E
	Through							
	Right Turn	12	12	95.8%	0.1	18.5	15.3	C
	Subtotal	36	36	100.6%	0.0	34.7	20.4	D
SB	Left Turn							
	Through							
	Right Turn							
	Subtotal							
EB	Left Turn							
	Through	366	371	101.3%	0.3	0.8	0.1	A
	Right Turn	78	79	101.0%	0.1	0.2	0.1	A
	Subtotal	444	450	101.3%	0.3	0.7	0.1	A
WB	Left Turn	6	5	83.3%	0.4	9.0	4.0	A
	Through	442	456	103.1%	0.7	5.0	0.9	A
	Right Turn							
	Subtotal	448	461	102.9%	0.6	5.1	0.9	A
Total		928	947	102.0%	0.6	4.2	1.1	A

Intersection **S B Street/9th Avenue**

Signalized

Direction	Movement	Volume (veh/hr)			GEH	Total Delay (sec/veh)		
		Demand	Served	% Served		Average	Std. Dev.	LOS
NB	Left Turn	9	9	96.7%	0.1	20.7	4.8	C
	Through	106	111	104.2%	0.4	13.8	1.4	B
	Right Turn	154	155	100.9%	0.1	7.6	1.2	A
	Subtotal	269	275	102.1%	0.3	10.5	1.4	B
SB	Left Turn	73	74	101.5%	0.1	18.9	2.8	B
	Through	49	57	115.7%	1.1	8.6	2.3	A
	Right Turn	39	40	101.8%	0.1	4.5	1.2	A
	Subtotal	161	171	105.9%	0.7	12.2	1.1	B
EB	Left Turn	31	31	101.3%	0.1	34.5	11.2	C
	Through	217	217	100.0%	0.0	27.8	6.2	C
	Right Turn	4	5	120.0%	0.4	22.7	19.2	C
	Subtotal	252	253	100.5%	0.1	28.5	7.0	C
WB	Left Turn	94	99	105.7%	0.5	15.6	2.5	B
	Through	285	290	101.9%	0.3	11.8	1.1	B
	Right Turn	87	88	100.7%	0.1	6.5	1.1	A
	Subtotal	466	477	102.4%	0.5	11.6	1.1	B
Total		1148	1176	102.4%	0.8	15.0	1.2	B

SimTraffic Post-Processor
Average Results from 20 Runs
Volume and Delay by Movement

Caltrain Electrification
Existing Conditions
AM Peak Hour

Intersection

Concar Drive/SR 92 WB Ramps

Signalized

Direction	Movement	Volume (veh/hr)			GEH	Total Delay (sec/veh)		
		Demand	Served	% Served		Average	Std. Dev.	LOS
NB	Left Turn	23	25	106.5%	0.3	22.0	1.2	C
	Through	47	49	103.2%	0.2	21.3	2.0	C
	Right Turn							
	Subtotal	70	73	104.3%	0.4	21.6	1.3	C
SB	Left Turn							
	Through	9	8	93.3%	0.2	18.6	5.2	B
	Right Turn	2	3	140.0%	0.5	3.0	1.3	A
	Subtotal	11	11	101.8%	0.1	14.3	3.6	B
EB	Left Turn							
	Through	55	52	93.8%	0.5	24.1	1.9	C
	Right Turn	24	23	93.8%	0.3	10.5	1.7	B
	Subtotal	79	74	93.8%	0.6	19.9	1.6	B
WB	Left Turn	689	677	98.3%	0.4	2.9	0.4	A
	Through	24	25	102.9%	0.1	4.7	1.6	A
	Right Turn	17	18	107.1%	0.3	0.8	0.4	A
	Subtotal	730	720	98.7%	0.4	2.9	0.4	A
Total		890	879	98.7%	0.4	6.0	0.6	A

SimTraffic Post-Processor
Average Results from 20 Runs
Volume and Delay by Movement

Caltrain Electrification
Existing Conditions
AM Peak Hour

Intersection Delaware Ave/25th Ave

Signalized

Direction	Movement	Volume (veh/hr)			GEH	Total Delay (sec/veh)		
		Demand	Served	% Served		Average	Std. Dev.	LOS
NB	Left Turn	20	19	93.5%	0.3	25.7	5.1	C
	Through	10	10	103.0%	0.1	15.1	9.8	B
	Right Turn							
	Subtotal	30	29	96.7%	0.2	22.1	5.2	C
SB	Left Turn							
	Through	27	28	104.1%	0.2	16.7	5.8	B
	Right Turn	521	523	100.4%	0.1	4.4	1.0	A
	Subtotal	548	551	100.6%	0.1	5.0	1.1	A
EB	Left Turn	517	511	98.8%	0.3	34.7	2.6	C
	Through							
	Right Turn	40	40	99.8%	0.0	11.8	4.1	B
	Subtotal	557	551	98.8%	0.3	33.0	2.4	C
WB	Left Turn							
	Through							
	Right Turn							
	Subtotal							
Total		1135	1131	99.6%	0.1	19.1	0.8	B

Intersection El Camino Real/25th Ave

Signalized

Direction	Movement	Volume (veh/hr)			GEH	Total Delay (sec/veh)		
		Demand	Served	% Served		Average	Std. Dev.	LOS
NB	Left Turn	37	35	94.3%	0.4	50.4	4.7	D
	Through	1012	987	97.6%	0.8	16.2	0.9	B
	Right Turn	324	319	98.5%	0.3	17.4	1.5	B
	Subtotal	1373	1341	97.7%	0.9	17.3	0.9	B
SB	Left Turn	72	66	91.5%	0.7	45.9	4.0	D
	Through	1066	1045	98.0%	0.7	14.0	0.8	B
	Right Turn	55	57	104.0%	0.3	14.3	1.7	B
	Subtotal	1193	1168	97.9%	0.7	15.8	0.9	B
EB	Left Turn	148	150	101.4%	0.2	42.0	6.3	D
	Through	161	156	96.7%	0.4	63.8	11.6	E
	Right Turn	36	35	98.3%	0.1	20.7	6.6	C
	Subtotal	345	341	98.9%	0.2	49.8	8.3	D
WB	Left Turn	364	365	100.4%	0.1	92.7	19.1	F
	Through	116	120	103.4%	0.4	101.7	18.5	F
	Right Turn	61	63	102.6%	0.2	54.7	17.8	D
	Subtotal	541	548	101.3%	0.3	90.3	18.3	F
Total		3452	3398	98.4%	0.9	32.0	3.4	C

SimTraffic Post-Processor
Average Results from 20 Runs
Volume and Delay by Movement

Caltrain Electrification
Existing Conditions
AM Peak Hour

Intersection **El Camino Real/31st Street**

Signalized

Direction	Movement	Volume (veh/hr)			GEH	Total Delay (sec/veh)		
		Demand	Served	% Served		Average	Std. Dev.	LOS
NB	Left Turn	60	61	102.3%	0.2	68.0	14.2	E
	Through	1253	1253	100.0%	0.0	15.3	1.1	B
	Right Turn	112	112	99.7%	0.0	2.8	0.4	A
	Subtotal	1425	1426	100.0%	0.0	16.6	1.2	B
SB	Left Turn	55	55	100.5%	0.0	61.2	11.5	E
	Through	1222	1224	100.1%	0.0	16.8	1.1	B
	Right Turn	114	115	100.6%	0.1	10.8	1.6	B
	Subtotal	1391	1394	100.2%	0.1	18.0	0.9	B
EB	Left Turn	114	108	94.9%	0.6	58.0	5.9	E
	Through	45	43	96.4%	0.2	79.4	13.5	E
	Right Turn	164	163	99.2%	0.1	6.3	0.7	A
	Subtotal	323	314	97.3%	0.5	34.3	3.3	C
WB	Left Turn	17	15	90.0%	0.4	29.9	5.7	C
	Through	59	59	100.3%	0.0	30.7	5.6	C
	Right Turn	56	57	100.9%	0.1	14.4	2.6	B
	Subtotal	132	131	99.2%	0.1	23.5	3.5	C
Total		3271	3265	99.8%	0.1	19.2	0.9	B

Intersection **El Camino Real/Hillsdale Blvd**

Signalized

Direction	Movement	Volume (veh/hr)			GEH	Total Delay (sec/veh)		
		Demand	Served	% Served		Average	Std. Dev.	LOS
NB	Left Turn							
	Through							
	Right Turn							
	Subtotal							
SB	Left Turn	340	342	100.7%	0.1	56.6	2.4	E
	Through							
	Right Turn	56	58	102.7%	0.2	4.2	0.9	A
	Subtotal	396	400	101.0%	0.2	49.1	2.6	D
EB	Left Turn							
	Through	436	436	100.0%	0.0	63.7	3.0	E
	Right Turn	46	46	100.0%	0.0	18.6	4.9	B
	Subtotal	482	482	100.0%	0.0	59.4	2.8	E
WB	Left Turn	253	240	95.0%	0.8	14.3	2.8	B
	Through	495	486	98.1%	0.4	13.1	1.4	B
	Right Turn							
	Subtotal	748	726	97.0%	0.8	13.5	1.5	B
Total		2453	2437	99.3%	0.3	43.7	0.8	D

SimTraffic Post-Processor
Average Results from 20 Runs
Volume and Delay by Movement

Caltrain Electrification
Existing Conditions
AM Peak Hour

Intersection **Curtiss Street/Hillsdale Blvd**

Signalized

Direction	Movement	Volume (veh/hr)			GEH	Total Delay (sec/veh)		
		Demand	Served	% Served		Average	Std. Dev.	LOS
NB	Left Turn	120	112	93.1%	0.8	29.7	2.4	C
	Through	8	9	107.5%	0.2	28.0	5.5	C
	Right Turn	123	124	101.0%	0.1	16.5	1.0	B
	Subtotal	251	245	97.4%	0.4	22.9	1.0	C
SB	Left Turn	30	28	91.7%	0.5	26.9	5.6	C
	Through	7	6	88.6%	0.3	28.4	11.3	C
	Right Turn	30	31	102.3%	0.1	14.4	3.1	B
	Subtotal	67	64	96.1%	0.3	21.1	4.2	C
EB	Left Turn	6	5	76.7%	0.6	31.3	11.8	C
	Through	1028	1030	100.2%	0.1	10.5	1.1	B
	Right Turn	66	62	94.2%	0.5	9.8	1.0	A
	Subtotal	1100	1097	99.7%	0.1	10.6	1.1	B
WB	Left Turn	22	25	111.8%	0.5	27.6	4.3	C
	Through	1165	1154	99.1%	0.3	10.4	1.0	B
	Right Turn	21	22	102.4%	0.1	7.4	1.5	A
	Subtotal	1208	1200	99.3%	0.2	10.7	1.0	B
Total		2626	2606	99.2%	0.4	12.0	0.7	B

SimTraffic Post-Processor
Average Results from 20 Runs
Volume and Delay by Movement

Caltrain Electrification
Existing Conditions
AM Peak Hour

Intersection

El Camino Real/Ralston Avenue

Signalized

Direction	Movement	Volume (veh/hr)			GEH	Total Delay (sec/veh)		
		Demand	Served	% Served		Average	Std. Dev.	LOS
NB	Left Turn	88	87	99.3%	0.1	65.3	4.7	E
	Through	570	595	104.4%	1.0	42.6	1.8	D
	Right Turn	185	193	104.2%	0.6	10.4	1.1	B
	Subtotal	843	875	103.8%	1.1	37.7	1.6	D
SB	Left Turn	325	274	84.4%	2.9	468.2	89.0	F
	Through	922	843	91.5%	2.6	191.2	63.9	F
	Right Turn	75	70	93.2%	0.6	161.5	51.8	F
	Subtotal	1322	1188	89.8%	3.8	253.6	70.1	F
EB	Left Turn	159	151	94.8%	0.7	196.1	61.1	F
	Through	775	731	94.3%	1.6	206.4	59.7	F
	Right Turn	43	37	85.3%	1.0	215.6	65.4	F
	Subtotal	977	918	94.0%	1.9	205.1	60.0	F
WB	Left Turn	156	153	98.2%	0.2	41.4	2.4	D
	Through	530	516	97.4%	0.6	45.3	1.2	D
	Right Turn	165	169	102.4%	0.3	9.1	1.1	A
	Subtotal	851	838	98.5%	0.4	37.3	1.1	D
Total		3993	3820	95.7%	2.8	144.8	11.5	F

SimTraffic Post-Processor
Average Results from 20 Runs
Volume and Delay by Movement

Caltrain Electrification
Existing Conditions
AM Peak Hour

Intersection

El Camino Real/San Carlos Avenue-Caltrain Station

Signalized

Direction	Movement	Volume (veh/hr)			GEH	Total Delay (sec/veh)		
		Demand	Served	% Served		Average	Std. Dev.	LOS
NB	Left Turn	84	79	94.0%	0.6	58.3	3.4	E
	Through	643	646	100.5%	0.1	17.1	0.9	B
	Right Turn	10	8	82.0%	0.6	18.2	6.9	B
	Subtotal	737	733	99.5%	0.1	21.5	0.6	C
SB	Left Turn	22	20	92.7%	0.3	64.0	7.6	E
	Through	867	875	100.9%	0.3	26.0	1.2	C
	Right Turn	276	282	102.2%	0.4	10.5	0.6	B
	Subtotal	1165	1177	101.1%	0.4	22.9	1.1	C
EB	Left Turn	497	489	98.4%	0.4	35.1	0.9	D
	Through	39	46	117.7%	1.1	32.9	4.6	C
	Right Turn	218	214	98.0%	0.3	29.2	1.8	C
	Subtotal	754	749	99.3%	0.2	33.2	0.8	C
WB	Left Turn	11	11	100.9%	0.0	62.2	12.6	E
	Through	12	12	97.5%	0.1	56.2	9.5	E
	Right Turn	16	19	119.4%	0.7	12.1	2.1	B
	Subtotal	39	42	107.4%	0.5	38.0	7.3	D
Total		2695	2701	100.2%	0.1	25.6	0.6	C

Intersection **California/Broadway**

Unsignalized

Direction	Movement	Volume (veh/hr)			GEH	Total Delay (sec/veh)		
		Demand	Served	% Served		Average	Std. Dev.	LOS
NB	Left Turn	10	11	106.0%	0.2	58.9	33.5	F
	Through	17	20	118.8%	0.7	50.5	29.6	F
	Right Turn	56	51	91.1%	0.7	63.9	44.8	F
	Subtotal	83	82	98.6%	0.1	60.0	38.3	F
SB	Left Turn	19	18	96.8%	0.1	60.0	25.9	F
	Through	12	12	100.0%	0.0	47.1	31.8	E
	Right Turn	15	15	100.7%	0.0	24.4	17.6	C
	Subtotal	46	46	98.9%	0.1	44.4	20.6	E
EB	Left Turn	27	26	96.7%	0.2	25.3	14.3	D
	Through	316	305	96.6%	0.6	24.9	9.2	C
	Right Turn	47	49	103.8%	0.3	22.5	10.9	C
	Subtotal	390	380	97.4%	0.5	24.6	9.5	C
WB	Left Turn	42	44	105.2%	0.3	10.9	2.4	B
	Through	134	137	102.1%	0.2	4.8	1.2	A
	Right Turn	21	19	91.4%	0.4	0.3	0.2	A
	Subtotal	197	200	101.6%	0.2	5.7	1.4	A
Total		716	708	98.8%	0.3	24.8	9.6	C

Intersection **Arguello Street/Brewster Ave**

Signalized

Direction	Movement	Volume (veh/hr)			GEH	Total Delay (sec/veh)		
		Demand	Served	% Served		Average	Std. Dev.	LOS
NB	Left Turn	18	18	99.4%	0.0	54.2	11.2	D
	Through	100	103	103.1%	0.3	23.1	2.5	C
	Right Turn	10	12	116.0%	0.5	4.4	2.5	A
	Subtotal	128	133	103.6%	0.4	25.5	2.4	C
SB	Left Turn	36	38	105.3%	0.3	61.0	10.1	E
	Through	97	96	99.0%	0.1	34.4	6.9	C
	Right Turn	134	134	100.1%	0.0	24.7	7.4	C
	Subtotal	267	268	100.4%	0.1	33.3	6.7	C
EB	Left Turn	78	78	99.7%	0.0	4.0	0.8	A
	Through	497	497	100.0%	0.0	2.9	0.3	A
	Right Turn	41	42	102.4%	0.2	0.9	0.3	A
	Subtotal	616	617	100.1%	0.0	2.9	0.2	A
WB	Left Turn	23	21	92.2%	0.4	30.4	8.1	C
	Through	139	137	98.6%	0.2	19.1	4.2	B
	Right Turn	12	13	106.7%	0.2	10.2	7.5	B
	Subtotal	174	171	98.3%	0.2	19.9	4.4	B
Total		1185	1189	100.3%	0.1	14.7	2.1	B

Intersection El Camino Real/Broadway

Signalized

Direction	Movement	Volume (veh/hr)			GEH	Total Delay (sec/veh)		
		Demand	Served	% Served		Average	Std. Dev.	LOS
NB	Left Turn	150	154	102.9%	0.3	56.9	3.8	E
	Through	1054	1081	102.6%	0.8	20.4	1.9	C
	Right Turn	76	70	91.8%	0.7	11.0	3.5	B
	Subtotal	1280	1305	102.0%	0.7	24.2	1.8	C
SB	Left Turn	100	100	99.8%	0.0	67.3	9.5	E
	Through	992	1002	101.0%	0.3	17.4	1.5	B
	Right Turn	8	10	125.0%	0.7	8.0	2.6	A
	Subtotal	1100	1112	101.1%	0.4	21.7	1.9	C
EB	Left Turn	4	4	110.0%	0.2	58.0	32.7	E
	Through	214	205	96.0%	0.6	57.9	14.7	E
	Right Turn	280	289	103.0%	0.5	38.0	12.1	D
	Subtotal	498	498	100.1%	0.0	46.4	13.1	D
WB	Left Turn	29	29	101.4%	0.1	52.4	9.1	D
	Through	94	98	104.0%	0.4	34.9	3.5	C
	Right Turn	36	34	94.2%	0.4	22.9	3.3	C
	Subtotal	159	161	101.3%	0.2	35.7	3.7	D
Total		3037	3077	101.3%	0.7	27.5	3.3	C

Intersection Arguello St/Marshall St

Signalized

Direction	Movement	Volume (veh/hr)			GEH	Total Delay (sec/veh)		
		Demand	Served	% Served		Average	Std. Dev.	LOS
NB	Left Turn	35	38	107.1%	0.4	32.9	5.9	C
	Through	52	54	103.7%	0.3	25.6	5.0	C
	Right Turn	12	14	112.5%	0.4	14.3	5.7	B
	Subtotal	99	105	106.0%	0.6	26.7	4.7	C
SB	Left Turn	43	39	90.9%	0.6	41.6	7.8	D
	Through	80	84	104.6%	0.4	26.6	4.5	C
	Right Turn	38	38	100.0%	0.0	24.6	7.8	C
	Subtotal	161	161	99.9%	0.0	29.6	5.0	C
EB	Left Turn	30	28	93.0%	0.4	6.1	1.7	A
	Through	282	274	97.1%	0.5	3.5	0.5	A
	Right Turn	79	72	91.0%	0.8	0.9	0.2	A
	Subtotal	391	374	95.5%	0.9	3.2	0.5	A
WB	Left Turn	7	7	92.9%	0.2	31.7	13.3	C
	Through	124	126	101.7%	0.2	25.8	7.2	C
	Right Turn	46	51	111.1%	0.7	4.4	1.9	A
	Subtotal	177	184	103.8%	0.5	20.1	5.1	C
Total		828	823	99.4%	0.2	15.1	2.2	B

SimTraffic Post-Processor
Average Results from 20 Runs
Volume and Delay by Movement

Caltrain Electrification
Existing Conditions
AM Peak Hour

Intersection

El Camino Real/James

Signalized

Direction	Movement	Volume (veh/hr)			GEH	Total Delay (sec/veh)		
		Demand	Served	% Served		Average	Std. Dev.	LOS
NB	Left Turn	175	166	94.9%	0.7	63.7	7.2	E
	Through	1158	1100	95.0%	1.7	18.8	0.8	B
	Right Turn	60	56	93.2%	0.5	9.4	0.6	A
	Subtotal	1393	1322	94.9%	1.9	24.1	1.2	C
SB	Left Turn	93	89	95.6%	0.4	64.9	3.0	E
	Through	1172	1130	96.4%	1.3	12.1	1.0	B
	Right Turn	105	101	96.4%	0.4	7.1	1.0	A
	Subtotal	1370	1320	96.3%	1.4	15.2	0.8	B
EB	Left Turn	144	135	93.4%	0.8	103.6	62.0	F
	Through	94	84	88.9%	1.1	51.0	31.3	D
	Right Turn	173	167	96.3%	0.5	37.8	39.7	D
	Subtotal	411	385	93.6%	1.3	63.7	44.8	E
WB	Left Turn	63	59	94.1%	0.5	45.2	4.4	D
	Through	107	102	95.2%	0.5	43.8	3.6	D
	Right Turn	45	45	99.1%	0.1	28.7	4.8	C
	Subtotal	215	206	95.7%	0.6	41.0	3.1	D
Total		3389	3232	95.4%	2.7	26.2	5.2	C

SimTraffic Post-Processor
Average Results from 20 Runs
Volume and Delay by Movement

Caltrain Electrification
Existing Conditions
AM Peak Hour

Intersection

El Camino Real/Atherton Avenue-Fair Oaks Lane

Signalized

Direction	Movement	Volume (veh/hr)			GEH	Total Delay (sec/veh)		
		Demand	Served	% Served		Average	Std. Dev.	LOS
NB	Left Turn	72	71	97.9%	0.2	44.4	3.7	D
	Through	789	812	102.9%	0.8	19.7	0.7	B
	Right Turn	28	26	91.4%	0.5	18.5	4.7	B
	Subtotal	889	908	102.1%	0.6	21.6	0.7	C
SB	Left Turn	64	64	100.2%	0.0	53.5	5.8	D
	Through	1683	1714	101.8%	0.7	36.0	2.4	D
	Right Turn	170	172	101.1%	0.1	44.1	4.4	D
	Subtotal	1917	1950	101.7%	0.7	37.3	2.5	D
EB	Left Turn	110	108	98.4%	0.2	49.0	5.1	D
	Through	74	69	92.8%	0.6	45.9	4.6	D
	Right Turn	118	112	95.2%	0.5	28.0	4.9	C
	Subtotal	302	289	95.8%	0.7	40.1	4.1	D
WB	Left Turn	77	75	97.9%	0.2	46.8	6.3	D
	Through	127	123	97.2%	0.3	44.6	3.3	D
	Right Turn	62	58	93.5%	0.5	20.1	5.1	C
	Subtotal	266	257	96.5%	0.6	39.7	3.8	D
Total		3374	3403	100.9%	0.5	33.6	1.6	C

Intersection

El Camino Real/Watkins Avenue

Unsignalized

Direction	Movement	Volume (veh/hr)			GEH	Total Delay (sec/veh)		
		Demand	Served	% Served		Average	Std. Dev.	LOS
NB	Left Turn							
	Through	821	832	101.3%	0.4	0.9	0.1	A
	Right Turn	60	63	104.7%	0.4	1.6	0.2	A
	Subtotal	881	895	101.5%	0.5	0.9	0.1	A
SB	Left Turn	61	53	87.0%	1.0	10.2	1.2	B
	Through	1817	1855	102.1%	0.9	5.1	0.1	A
	Right Turn							
	Subtotal	1878	1909	101.6%	0.7	5.3	0.1	A
EB	Left Turn							
	Through							
	Right Turn							
	Subtotal							
WB	Left Turn	69	68	97.8%	0.2	43.0	8.0	E
	Through							
	Right Turn	68	70	103.5%	0.3	26.4	5.8	D
	Subtotal	137	138	100.7%	0.1	34.5	6.9	D
Total		2896	2941	101.6%	0.8	5.3	0.4	A

Intersection El Camino Real/Glenwood

Signalized

Direction	Movement	Volume (veh/hr)			GEH	Total Delay (sec/veh)		
		Demand	Served	% Served		Average	Std. Dev.	LOS
NB	Left Turn	67	69	102.5%	0.2	49.3	4.1	D
	Through	735	741	100.8%	0.2	9.3	0.3	A
	Right Turn	34	37	109.7%	0.6	5.0	0.5	A
	Subtotal	836	847	101.3%	0.4	12.3	0.6	B
SB	Left Turn	63	63	99.7%	0.0	65.9	22.5	E
	Through	1355	1330	98.2%	0.7	45.8	21.6	D
	Right Turn	462	447	96.7%	0.7	12.7	6.9	B
	Subtotal	1880	1840	97.9%	0.9	38.5	17.9	D
EB	Left Turn	258	262	101.7%	0.3	52.4	16.1	D
	Through	147	150	102.0%	0.2	58.2	17.1	E
	Right Turn	85	86	101.6%	0.2	27.5	9.8	C
	Subtotal	490	499	101.8%	0.4	49.9	15.6	D
WB	Left Turn	66	67	102.0%	0.2	39.8	2.8	D
	Through	187	191	102.2%	0.3	41.9	4.5	D
	Right Turn	11	10	94.5%	0.2	32.6	8.3	C
	Subtotal	264	269	101.8%	0.3	41.0	3.6	D
Total		3470	3454	99.5%	0.3	34.1	9.9	C

Intersection El Camino Real/Oak Grove

Signalized

Direction	Movement	Volume (veh/hr)			GEH	Total Delay (sec/veh)		
		Demand	Served	% Served		Average	Std. Dev.	LOS
NB	Left Turn	87	85	97.2%	0.3	37.9	7.5	D
	Through	737	752	102.0%	0.5	7.9	0.7	A
	Right Turn	73	75	102.6%	0.2	3.2	0.7	A
	Subtotal	897	911	101.6%	0.5	10.3	1.0	B
SB	Left Turn	102	94	91.7%	0.9	55.5	4.1	E
	Through	1337	1323	99.0%	0.4	10.7	4.7	B
	Right Turn	67	66	99.1%	0.1	9.5	3.0	A
	Subtotal	1506	1483	98.5%	0.6	13.5	4.3	B
EB	Left Turn	60	58	96.0%	0.3	57.3	8.8	E
	Through	176	174	98.6%	0.2	39.4	5.3	D
	Right Turn	48	48	100.8%	0.1	23.7	3.2	C
	Subtotal	284	280	98.5%	0.3	40.4	4.5	D
WB	Left Turn	109	105	96.1%	0.4	50.6	8.0	D
	Through	198	197	99.4%	0.1	38.1	5.5	D
	Right Turn	39	42	107.7%	0.5	11.7	3.2	B
	Subtotal	346	344	99.3%	0.1	38.7	5.5	D
Total		3033	3018	99.5%	0.3	17.9	2.3	B

Intersection El Camino Real/Santa Cruz Ave

Signalized

Direction	Movement	Volume (veh/hr)			GEH	Total Delay (sec/veh)		
		Demand	Served	% Served		Average	Std. Dev.	LOS
NB	Left Turn							
	Through	772	798	103.4%	0.9	2.7	0.3	A
	Right Turn	46	44	95.4%	0.3	2.4	0.6	A
	Subtotal	818	842	102.9%	0.8	2.7	0.3	A
SB	Left Turn							
	Through	1407	1391	98.9%	0.4	7.1	4.0	A
	Right Turn	87	88	100.6%	0.1	4.6	2.3	A
	Subtotal	1494	1478	99.0%	0.4	7.0	3.9	A
EB	Left Turn	99	102	102.8%	0.3	39.3	2.4	D
	Through	61	60	98.5%	0.1	33.0	4.2	C
	Right Turn	68	68	99.3%	0.1	23.5	3.2	C
	Subtotal	228	229	100.6%	0.1	33.0	2.7	C
WB	Left Turn	62	57	91.5%	0.7	33.3	4.3	C
	Through	64	66	102.3%	0.2	31.0	4.1	C
	Right Turn	26	29	112.3%	0.6	18.1	4.0	B
	Subtotal	152	151	99.6%	0.0	29.3	2.9	C
Total		2692	2701	100.3%	0.2	9.1	2.4	A

Intersection Merril St/Santa Cruz Ave

Unsignalized

Direction	Movement	Volume (veh/hr)			GEH	Total Delay (sec/veh)		
		Demand	Served	% Served		Average	Std. Dev.	LOS
NB	Left Turn	60	57	94.7%	0.4	7.1	1.8	A
	Through	15	18	118.7%	0.7	7.8	2.7	A
	Right Turn							
	Subtotal	75	75	99.5%	0.0	7.3	1.8	A
SB	Left Turn	4	4	97.5%	0.1	6.7	1.0	A
	Through	22	22	101.8%	0.1	8.9	0.6	A
	Right Turn	78	80	102.2%	0.2	5.3	0.5	A
	Subtotal	104	106	101.9%	0.2	6.1	0.4	A
EB	Left Turn	75	75	100.5%	0.0	6.5	0.7	A
	Through	15	15	100.0%	0.0	7.0	1.0	A
	Right Turn	17	15	85.3%	0.6	5.0	0.9	A
	Subtotal	107	105	98.0%	0.2	6.3	0.6	A
WB	Left Turn							
	Through	14	13	95.7%	0.2	3.3	0.4	A
	Right Turn	7	7	104.3%	0.1	2.7	0.5	A
	Subtotal	21	21	98.6%	0.1	3.1	0.3	A
Total		307	306	99.7%	0.0	6.3	0.5	A

SimTraffic Post-Processor
Average Results from 20 Runs
Volume and Delay b Movement

Caltrain Electrification
Existing Conditions
AM Peak Hour

Intersection Ravenswood Ave/Laurel St

Signalized

Direction	Movement	Volume (veh/hr)			GEH	Total Delay (sec/veh)		
		Demand	Served	% Served		Average	Std. Dev.	LOS
NB	Left Turn	168	155	92.1%	1.0	33.4	3.6	C
	Through	63	64	101.7%	0.1	19.9	1.9	B
	Right Turn	27	25	94.1%	0.3	15.7	3.5	B
	Subtotal	258	244	94.7%	0.9	28.0	2.3	C
SB	Left Turn	162	143	88.4%	1.5	55.7	15.1	E
	Through	174	168	96.3%	0.5	55.6	17.3	E
	Right Turn	79	77	98.0%	0.2	47.6	16.6	D
	Subtotal	415	388	93.5%	1.3	54.0	16.1	D
EB	Left Turn	32	30	92.8%	0.4	42.4	6.0	D
	Through	772	722	93.5%	1.8	31.2	3.2	C
	Right Turn	105	100	94.8%	0.5	29.0	5.7	C
	Subtotal	909	851	93.6%	2.0	31.4	3.3	C
WB	Left Turn	18	19	105.6%	0.2	55.3	9.6	E
	Through	589	576	97.8%	0.5	15.6	1.5	B
	Right Turn	16	15	94.4%	0.2	11.2	4.2	B
	Subtotal	623	610	98.0%	0.5	16.7	1.7	B
Total		2205	2093	94.9%	2.4	31.0	4.3	C

SimTraffic Post-Processor
Average Results from 20 Runs
Volume and Delay by Movement

Caltrain Electrification
Existing Conditions
AM Peak Hour

Intersection

High Street/University Ave

Signalized

Direction	Movement	Volume (veh/hr)			GEH	Total Delay (sec/veh)		
		Demand	Served	% Served		Average	Std. Dev.	LOS
NB	Left Turn							
	Through							
	Right Turn							
	Subtotal							
SB	Left Turn	11	12	106.4%	0.2	19.6	5.8	B
	Through	28	30	108.6%	0.4	13.9	3.1	B
	Right Turn	215	215	100.1%	0.0	11.8	1.0	B
	Subtotal	254	257	101.3%	0.2	12.4	1.0	B
EB	Left Turn							
	Through	451	456	101.1%	0.2	11.5	0.8	B
	Right Turn	215	220	102.4%	0.4	3.5	0.4	A
	Subtotal	666	676	101.5%	0.4	8.9	0.6	A
WB	Left Turn	11	9	80.9%	0.7	26.4	6.8	C
	Through	535	543	101.5%	0.3	17.1	1.1	B
	Right Turn							
	Subtotal	546	552	101.1%	0.3	17.3	1.1	B
Total		1466	1486	101.3%	0.5	12.6	0.5	B

SimTraffic Post-Processor
Average Results from 20 Runs
Volume and Delay by Movement

Caltrain Electrification
Existing Conditions
AM Peak Hour

Intersection

Showers Drive/Pacchetti Way

Signalized

Direction	Movement	Volume (veh/hr)			GEH	Total Delay (sec/veh)		
		Demand	Served	% Served		Average	Std. Dev.	LOS
NB	Left Turn	11	10	90.0%	0.3	22.6	2.1	C
	Through	24	24	99.2%	0.0	2.0	1.2	A
	Right Turn							
	Subtotal	35	34	96.3%	0.2	8.2	2.5	A
SB	Left Turn							
	Through	53	56	104.7%	0.3	3.0	1.0	A
	Right Turn	21	17	82.9%	0.8	1.0	0.8	A
	Subtotal	74	73	98.5%	0.1	2.5	0.9	A
EB	Left Turn	4	4	90.0%	0.2	13.1	3.4	B
	Through							
	Right Turn							
	Subtotal	4	4	90.0%	0.2	13.1	3.4	B
WB	Left Turn							
	Through							
	Right Turn							
	Subtotal							
Total		113	110	97.5%	0.3	4.5	1.2	A

SimTraffic Post-Processor
Average Results from 20 Runs
Volume and Delay by Movement

Caltrain Electrification
Existing Conditions
AM Peak Hour

Intersection Hope Street/Evelyn Ave

Signalized

Direction	Movement	Volume (veh/hr)			GEH	Total Delay (sec/veh)		
		Demand	Served	% Served		Average	Std. Dev.	LOS
NB	Left Turn	19	16	82.6%	0.8	20.7	5.1	C
	Through							
	Right Turn	64	65	101.4%	0.1	4.9	0.7	A
	Subtotal	83	81	97.1%	0.3	8.0	1.6	A
SB	Left Turn							
	Through							
	Right Turn							
	Subtotal							
EB	Left Turn							
	Through	28	27	96.1%	0.2	1.5	0.5	A
	Right Turn	7	9	124.3%	0.6	1.3	0.7	A
	Subtotal	35	36	101.7%	0.1	1.4	0.4	A
WB	Left Turn	48	49	102.1%	0.1	1.6	0.5	A
	Through	270	274	101.4%	0.2	2.0	0.3	A
	Right Turn							
	Subtotal	318	323	101.5%	0.3	2.0	0.3	A
Total		436	439	100.7%	0.1	3.0	0.4	A

Intersection Castro Street/Villa Street

Signalized

Direction	Movement	Volume (veh/hr)			GEH	Total Delay (sec/veh)		
		Demand	Served	% Served		Average	Std. Dev.	LOS
NB	Left Turn	16	15	90.6%	0.4	19.6	3.3	B
	Through	171	168	98.4%	0.2	12.7	1.2	B
	Right Turn	33	33	100.9%	0.1	6.5	1.2	A
	Subtotal	220	216	98.2%	0.3	12.2	1.0	B
SB	Left Turn	134	125	93.4%	0.8	9.7	0.8	A
	Through	197	198	100.4%	0.0	6.9	0.9	A
	Right Turn	7	7	102.9%	0.1	6.1	4.8	A
	Subtotal	338	330	97.6%	0.4	7.9	0.6	A
EB	Left Turn	49	45	92.7%	0.5	19.1	1.2	B
	Through	142	145	102.3%	0.3	14.3	1.4	B
	Right Turn	8	8	102.5%	0.1	7.4	3.2	A
	Subtotal	199	199	99.9%	0.0	15.1	1.3	B
WB	Left Turn	36	32	88.1%	0.7	17.9	1.6	B
	Through	159	156	97.9%	0.3	14.7	1.0	B
	Right Turn	39	41	105.9%	0.4	9.2	1.8	A
	Subtotal	234	229	97.7%	0.3	14.2	1.0	B
Total		991	974	98.3%	0.6	11.8	0.7	B

SimTraffic Post-Processor
Average Results from 20 Runs
Volume and Delay by Movement

Caltrain Electrification
Existing Conditions
AM Peak Hour

Intersection Frances St/Evelyn Ave

Signalized

Direction	Movement	Volume (veh/hr)			GEH	Total Delay (sec/veh)		
		Demand	Served	% Served		Average	Std. Dev.	LOS
NB	Left Turn	15	15	98.0%	0.1	21.7	6.7	C
	Through	13	14	106.2%	0.2	13.4	5.2	B
	Right Turn	8	9	110.0%	0.3	3.5	1.8	A
	Subtotal	36	37	103.6%	0.2	14.2	3.6	B
SB	Left Turn	65	60	92.9%	0.6	22.6	3.7	C
	Through	16	16	102.5%	0.1	18.7	4.2	B
	Right Turn	52	54	103.3%	0.2	11.4	2.4	B
	Subtotal	133	131	98.1%	0.2	17.7	2.6	B
EB	Left Turn	43	43	99.3%	0.0	44.7	8.3	D
	Through	191	192	100.3%	0.0	13.1	1.0	B
	Right Turn	24	23	96.3%	0.2	8.5	2.1	A
	Subtotal	258	257	99.8%	0.0	18.0	1.9	B
WB	Left Turn	39	37	95.6%	0.3	45.9	3.9	D
	Through	495	499	100.8%	0.2	14.9	1.6	B
	Right Turn	111	111	99.6%	0.0	5.6	1.5	A
	Subtotal	645	647	100.3%	0.1	15.1	1.7	B
Total		1072	1072	100.0%	0.0	16.1	1.5	B

SimTraffic Post-Processor
Average Results from 20 Runs
Volume and Delay by Movement

Caltrain Electrification
Existing Conditions
AM Peak Hour

Intersection Lawrence Expressway/Kifer Road

Signalized

Direction	Movement	Volume (veh/hr)			GEH	Total Delay (sec/veh)		
		Demand	Served	% Served		Average	Std. Dev.	LOS
NB	Left Turn	248	233	94.1%	0.9	161.2	8.5	F
	Through	4377	3976	90.8%	6.2	128.8	9.1	F
	Right Turn	523	468	89.4%	2.5	144.9	9.6	F
	Subtotal	5148	4677	90.9%	6.7	132.0	9.0	F
SB	Left Turn	210	208	99.2%	0.1	88.4	6.7	F
	Through	1276	1274	99.8%	0.1	18.5	1.6	B
	Right Turn	395	401	101.6%	0.3	14.0	1.5	B
	Subtotal	1881	1884	100.1%	0.1	25.3	2.1	C
EB	Left Turn	110	111	101.1%	0.1	89.9	5.0	F
	Through	145	148	101.9%	0.2	73.4	5.1	E
	Right Turn	151	153	101.1%	0.1	1.6	0.1	A
	Subtotal	406	412	101.4%	0.3	51.2	2.5	D
WB	Left Turn	70	74	105.4%	0.4	86.0	5.2	F
	Through	155	164	105.9%	0.7	75.6	4.7	E
	Right Turn	101	100	98.9%	0.1	10.9	4.0	B
	Subtotal	326	338	103.6%	0.6	58.6	4.1	E
Total		7761	7310	94.2%	5.2	96.6	6.1	F

Intersection Lawrence Expressway/Reed Ave-Monroe St

Signalized

Direction	Movement	Volume (veh/hr)			GEH	Total Delay (sec/veh)		
		Demand	Served	% Served		Average	Std. Dev.	LOS
NB	Left Turn	152	146	95.9%	0.5	138.9	9.6	F
	Through	4449	4248	95.5%	3.0	68.5	3.3	E
	Right Turn	103	103	99.8%	0.0	52.9	4.0	D
	Subtotal	4704	4497	95.6%	3.1	70.4	3.3	E
SB	Left Turn	82	81	99.1%	0.1	82.0	5.0	F
	Through	1256	1251	99.6%	0.1	28.1	1.4	C
	Right Turn	159	162	101.8%	0.2	8.4	0.3	A
	Subtotal	1497	1494	99.8%	0.1	28.9	1.1	C
EB	Left Turn	404	190	47.0%	12.4	1287.2	371.5	F
	Through	307	228	74.4%	4.8	156.1	40.1	F
	Right Turn	217	150	69.1%	5.0	41.5	25.1	D
	Subtotal	928	568	61.2%	13.2	499.2	131.3	F
WB	Left Turn	182	186	102.4%	0.3	140.5	45.0	F
	Through	222	223	100.5%	0.1	118.2	40.0	F
	Right Turn	295	299	101.2%	0.2	50.7	16.5	D
	Subtotal	699	708	101.3%	0.3	95.7	25.9	F
Total		7828	7268	92.8%	6.5	97.3	11.0	F

SimTraffic Post-Processor
Average Results from 20 Runs
Volume and Delay by Movement

Caltrain Electrification
Existing Conditions
AM Peak Hour

Intersection

El Camino Real/Railroad Avenue

Signalized

Direction	Movement	Volume (veh/hr)			GEH	Total Delay (sec/veh)		
		Demand	Served	% Served		Average	Std. Dev.	LOS
NB	Left Turn	198	192	96.7%	0.5	144.6	31.6	F
	Through	1037	1042	100.5%	0.2	8.2	0.6	A
	Right Turn	51	49	96.9%	0.2	8.8	2.5	A
	Subtotal	1286	1283	99.8%	0.1	28.5	4.7	C
SB	Left Turn	56	53	94.5%	0.4	80.1	6.1	F
	Through	384	387	100.9%	0.2	10.7	0.7	B
	Right Turn	99	100	101.1%	0.1	9.6	1.6	A
	Subtotal	539	540	100.2%	0.1	17.3	1.0	B
EB	Left Turn	8	9	113.8%	0.4	69.6	21.4	E
	Through	2	2	100.0%	0.0	51.6	45.8	D
	Right Turn	21	22	103.3%	0.2	8.0	1.0	A
	Subtotal	31	33	105.8%	0.3	27.9	8.2	C
WB	Left Turn	46	45	98.3%	0.1	79.1	9.0	E
	Through	14	14	100.7%	0.0	66.1	14.8	E
	Right Turn	38	38	99.2%	0.0	15.7	6.5	B
	Subtotal	98	97	99.0%	0.1	52.9	4.3	D
Total		1954	1953	100.0%	0.0	26.6	3.0	C

Intersection Santa Clara Street/Cahill Street

Signalized

Direction	Movement	Volume (veh/hr)			GEH	Total Delay (sec/veh)		
		Demand	Served	% Served		Average	Std. Dev.	LOS
NB	Left Turn	63	60	94.4%	0.4	24.8	3.6	C
	Through							
	Right Turn	76	75	98.7%	0.1	5.7	0.5	A
	Subtotal	139	135	96.8%	0.4	14.1	1.7	B
SB	Left Turn							
	Through							
	Right Turn							
	Subtotal							
EB	Left Turn							
	Through	452	476	105.4%	1.1	14.4	0.8	B
	Right Turn	47	49	103.6%	0.2	11.7	1.3	B
	Subtotal	499	525	105.2%	1.1	14.2	0.8	B
WB	Left Turn	230	229	99.7%	0.0	28.3	2.7	C
	Through	1003	1046	104.3%	1.4	4.1	0.5	A
	Right Turn	15	16	106.7%	0.3	2.7	1.6	A
	Subtotal	1248	1292	103.5%	1.2	8.4	0.6	A
Total		1886	1951	103.5%	1.5	10.4	0.4	B

Intersection San Fernando Street/Montgomery Street

Signalized

Direction	Movement	Volume (veh/hr)			GEH	Total Delay (sec/veh)		
		Demand	Served	% Served		Average	Std. Dev.	LOS
NB	Left Turn							
	Through							
	Right Turn							
	Subtotal							
SB	Left Turn	28	21	75.7%	1.4	12.8	1.2	B
	Through	203	201	99.0%	0.1	13.7	0.7	B
	Right Turn	7	8	115.7%	0.4	7.6	2.6	A
	Subtotal	238	230	96.7%	0.5	13.4	0.7	B
EB	Left Turn							
	Through	76	83	108.7%	0.7	3.9	0.9	A
	Right Turn	104	103	99.1%	0.1	2.2	0.3	A
	Subtotal	180	186	103.2%	0.4	3.0	0.5	A
WB	Left Turn	72	74	102.1%	0.2	7.2	0.7	A
	Through	122	128	104.8%	0.5	5.3	0.6	A
	Right Turn							
	Subtotal	194	201	103.8%	0.5	6.0	0.6	A
Total		612	617	100.9%	0.2	7.9	0.4	A

SimTraffic Post-Processor
Average Results from 20 Runs
Volume and Delay by Movement

Caltrain Electrification
Existing Conditions
AM Peak Hour

Intersection

Lick Avenue-Shadow Run Drive/Alma Avenue

Signalized

Direction	Movement	Volume (veh/hr)			GEH	Total Delay (sec/veh)		
		Demand	Served	% Served		Average	Std. Dev.	LOS
NB	Left Turn	30	29	97.0%	0.2	43.1	3.9	D
	Through	11	10	90.9%	0.3	40.1	7.3	D
	Right Turn	11	11	103.6%	0.1	9.3	6.4	A
	Subtotal	52	51	97.1%	0.2	35.1	3.2	D
SB	Left Turn	54	52	95.7%	0.3	47.0	2.2	D
	Through							
	Right Turn	38	41	106.6%	0.4	3.9	1.0	A
	Subtotal	92	92	100.2%	0.0	28.1	2.4	C
EB	Left Turn	29	32	109.0%	0.5	42.3	6.1	D
	Through	410	412	100.5%	0.1	12.2	0.8	B
	Right Turn	8	9	113.8%	0.4	9.5	3.9	A
	Subtotal	447	453	101.3%	0.3	14.2	0.7	B
WB	Left Turn	5	5	94.0%	0.1	58.3	13.6	E
	Through	570	573	100.5%	0.1	14.0	0.7	B
	Right Turn	159	155	97.2%	0.4	12.5	1.1	B
	Subtotal	734	732	99.8%	0.1	13.9	0.7	B
Total		1325	1328	100.2%	0.1	15.8	0.3	B

SimTraffic Post-Processor
Average Results from 20 Runs
Volume and Delay by Movement

Caltrain Electrification
Existing Conditions
AM Peak Hour

Intersection 7th Street/Mission Bay

Signalized

Direction	Movement	Volume (veh/hr)			GEH	Total Delay (sec/veh)		
		Demand	Served	% Served		Average	Std. Dev.	LOS
NB	Left Turn							
	Through	693	694	100.1%	0.0	7.6	0.7	A
	Right Turn	43	44	102.6%	0.2	19.4	5.8	B
	Subtotal	736	738	100.2%	0.1	8.3	0.6	A
SB	Left Turn	37	37	100.0%	0.0	42.9	7.4	D
	Through	249	241	96.7%	0.5	5.4	0.6	A
	Right Turn							
	Subtotal	286	278	97.2%	0.5	10.3	1.3	B
EB	Left Turn							
	Through							
	Right Turn							
	Subtotal							
WB	Left Turn	23	23	99.1%	0.0	3.4	1.4	A
	Through							
	Right Turn	62	60	97.3%	0.2	0.7	0.2	A
	Subtotal	85	83	97.8%	0.2	1.4	0.4	A
Total		1107	1099	99.2%	0.3	8.3	0.5	A

Intersection Berry Street/Mission Bay

Signalized

Direction	Movement	Volume (veh/hr)			GEH	Total Delay (sec/veh)		
		Demand	Served	% Served		Average	Std. Dev.	LOS
NB	Left Turn							
	Through							
	Right Turn							
	Subtotal							
SB	Left Turn							
	Through							
	Right Turn	85	84	98.8%	0.1	3.6	1.2	A
	Subtotal	85	84	98.8%	0.1	3.6	1.2	A
EB	Left Turn	80	81	101.5%	0.1	0.9	1.0	A
	Through							
	Right Turn							
	Subtotal	80	81	101.5%	0.1	0.9	1.0	A
WB	Left Turn							
	Through							
	Right Turn							
	Subtotal							
Total		165	165	100.1%	0.0	2.3	0.9	A

Intersection Main Street/Maple Street

Unsignalized

Direction	Movement	Volume (veh/hr)			GEH	Total Delay (sec/veh)		
		Demand	Served	% Served		Average	Std. Dev.	LOS
NB	Left Turn							
	Through	444	455	102.6%	0.5	1.7	0.3	A
	Right Turn							
	Subtotal	444	455	102.6%	0.5	1.7	0.3	A
SB	Left Turn							
	Through	294	291	98.9%	0.2	5.0	0.4	A
	Right Turn							
	Subtotal	294	291	98.9%	0.2	5.0	0.4	A
EB	Left Turn							
	Through							
	Right Turn							
	Subtotal							
WB	Left Turn	2	2	95.0%	0.1	19.4	14.1	C
	Through							
	Right Turn	6	7	111.7%	0.3	8.5	5.8	A
	Subtotal	8	9	107.5%	0.2	10.9	5.1	B
Total		746	755	101.2%	0.3	3.1	0.3	A

Intersection Main Street/Beech Street

Unsignalized

Direction	Movement	Volume (veh/hr)			GEH	Total Delay (sec/veh)		
		Demand	Served	% Served		Average	Std. Dev.	LOS
NB	Left Turn	69	67	97.5%	0.2	3.5	0.6	A
	Through	252	253	100.4%	0.1	1.2	0.2	A
	Right Turn							
	Subtotal	321	320	99.8%	0.0	1.7	0.3	A
SB	Left Turn							
	Through	182	195	107.3%	1.0	0.7	0.1	A
	Right Turn	50	55	109.0%	0.6	0.3	0.1	A
	Subtotal	232	250	107.7%	1.1	0.6	0.0	A
EB	Left Turn	21	21	101.9%	0.1	8.9	1.1	A
	Through							
	Right Turn	59	63	106.6%	0.5	4.1	0.4	A
	Subtotal	80	84	105.4%	0.5	5.2	0.5	A
WB	Left Turn							
	Through							
	Right Turn							
	Subtotal							
Total		633	654	103.4%	0.8	1.7	0.1	A

SimTraffic Post-Processor
 Average Results from 20 Runs
 Volume and Delay by Movement

Caltrain Electrification
 Existing Conditions
 AM Peak Hour

Intersection Main Street/Middlefield Road

Signalized

Direction	Movement	Volume (veh/hr)			GEH	Total Delay (sec/veh)		
		Demand	Served	% Served		Average	Std. Dev.	LOS
NB	Left Turn	40	39	97.5%	0.2	35.1	3.7	D
	Through	382	392	102.6%	0.5	14.4	0.9	B
	Right Turn	28	30	107.5%	0.4	3.4	1.0	A
	Subtotal	450	461	102.4%	0.5	15.4	0.8	B
SB	Left Turn	22	20	89.5%	0.5	31.7	3.3	C
	Through	232	234	100.6%	0.1	15.7	1.5	B
	Right Turn	44	46	105.5%	0.4	2.3	0.2	A
	Subtotal	298	300	100.5%	0.1	14.7	1.2	B
EB	Left Turn	57	59	102.8%	0.2	15.5	2.4	B
	Through	264	257	97.2%	0.5	12.0	1.3	B
	Right Turn	43	40	93.5%	0.4	7.1	1.5	A
	Subtotal	364	355	97.6%	0.5	12.0	1.3	B
WB	Left Turn	19	18	92.6%	0.3	7.4	3.5	A
	Through	108	107	99.4%	0.1	3.4	0.7	A
	Right Turn	64	63	98.8%	0.1	1.7	0.5	A
	Subtotal	191	188	98.5%	0.2	3.1	0.6	A
Total		1303	1304	100.1%	0.0	12.5	0.6	B

Intersection Fair Oaks Lane/Middlefield Road

Unsignalized

Direction	Movement	Volume (veh/hr)			GEH	Total Delay (sec/veh)		
		Demand	Served	% Served		Average	Std. Dev.	LOS
NB	Left Turn	13	10	80.0%	0.8	87.1	27.5	F
	Through	5	6	110.0%	0.2	91.1	55.1	F
	Right Turn	194	192	98.8%	0.2	46.5	20.6	E
	Subtotal	212	208	97.9%	0.3	49.7	20.8	E
SB	Left Turn	10	9	89.0%	0.4	237.4	101.5	F
	Through	66	67	102.1%	0.2	216.3	67.8	F
	Right Turn	48	52	107.5%	0.5	188.5	76.4	F
	Subtotal	124	128	103.1%	0.3	206.6	70.9	F
EB	Left Turn	3	3	86.7%	0.2	2.9	2.6	A
	Through	690	681	98.8%	0.3	4.3	0.4	A
	Right Turn	101	98	97.3%	0.3	3.0	0.4	A
	Subtotal	794	782	98.5%	0.4	4.1	0.3	A
WB	Left Turn	210	202	96.3%	0.5	20.1	2.7	C
	Through	427	438	102.5%	0.5	5.6	1.0	A
	Right Turn	15	17	111.3%	0.4	4.7	2.1	A
	Subtotal	652	657	100.7%	0.2	10.1	1.4	B
Total		1782	1774	99.6%	0.2	26.2	6.7	D

Intersection Watkins Avenue/Middlefield Road

Unsignalized

Direction	Movement	Volume (veh/hr)			GEH	Total Delay (sec/veh)		
		Demand	Served	% Served		Average	Std. Dev.	LOS
NB	Left Turn	53	50	93.6%	0.5	45.1	13.0	E
	Through							
	Right Turn	63	62	98.7%	0.1	20.8	8.9	C
	Subtotal	116	112	96.4%	0.4	31.6	9.5	D
SB	Left Turn							
	Through							
	Right Turn							
	Subtotal							
EB	Left Turn							
	Through	808	808	100.0%	0.0	4.4	0.2	A
	Right Turn	86	83	96.7%	0.3	3.6	0.3	A
	Subtotal	894	891	99.7%	0.1	4.4	0.2	A
WB	Left Turn	57	53	92.8%	0.6	14.2	1.5	B
	Through	599	606	101.1%	0.3	5.2	0.4	A
	Right Turn							
	Subtotal	656	658	100.4%	0.1	5.9	0.5	A
Total		1666	1662	99.7%	0.1	6.8	0.6	A

SimTraffic Post-Processor
Average Results from 20 Runs
Volume and Delay by Movement

Caltrain Electrification
Existing Conditions
AM Peak Hour

Intersection

Linden Avenue-Glenwood Avenue/Middlefield Road

Unsignalized

Direction	Movement	Volume (veh/hr)			GEH	Total Delay (sec/veh)		
		Demand	Served	% Served		Average	Std. Dev.	LOS
NB	Left Turn	67	66	98.7%	0.1	72.9	28.1	F
	Through	5	7	148.0%	1.0	72.9	42.3	F
	Right Turn	83	86	103.4%	0.3	28.7	14.5	D
	Subtotal	155	159	102.8%	0.3	49.2	20.6	E
SB	Left Turn	20	19	97.0%	0.1	47.0	23.1	E
	Through	9	9	96.7%	0.1	56.7	23.2	F
	Right Turn	30	28	91.7%	0.5	21.2	9.4	C
	Subtotal	59	56	94.2%	0.4	35.6	16.3	E
EB	Left Turn	45	42	94.0%	0.4	11.4	2.3	B
	Through	676	673	99.6%	0.1	8.8	0.4	A
	Right Turn	150	155	103.1%	0.4	7.4	0.7	A
	Subtotal	871	870	99.9%	0.0	8.7	0.4	A
WB	Left Turn	85	86	101.5%	0.1	15.6	2.0	C
	Through	559	556	99.4%	0.1	2.8	0.3	A
	Right Turn	7	8	114.3%	0.4	2.1	0.6	A
	Subtotal	651	650	99.9%	0.0	4.5	0.5	A
Total		1736	1735	100.0%	0.0	11.7	2.5	B

SimTraffic Post-Processor
Average Results from 20 Runs
Volume and Delay by Movement

Caltrain Electrification
Existing Conditions
AM Peak Hour

Intersection California Street/Rengstorff Avenue

Signalized

Direction	Movement	Volume (veh/hr)			GEH	Total Delay (sec/veh)		
		Demand	Served	% Served		Average	Std. Dev.	LOS
NB	Left Turn	51	51	99.0%	0.1	94.7	4.9	F
	Through	305	310	101.7%	0.3	29.3	4.2	C
	Right Turn	129	126	97.3%	0.3	25.1	4.4	C
	Subtotal	485	486	100.2%	0.1	35.0	2.9	C
SB	Left Turn	116	119	102.8%	0.3	88.1	7.0	F
	Through	202	206	101.8%	0.3	22.3	2.6	C
	Right Turn	57	55	95.8%	0.3	17.4	5.9	B
	Subtotal	375	379	101.2%	0.2	42.2	3.0	D
EB	Left Turn	49	44	89.6%	0.7	102.0	10.0	F
	Through	367	352	95.9%	0.8	58.3	3.8	E
	Right Turn	25	27	106.8%	0.3	50.5	10.9	D
	Subtotal	441	423	95.8%	0.9	62.3	3.4	E
WB	Left Turn	100	91	90.6%	1.0	100.1	6.3	F
	Through	281	282	100.4%	0.1	54.5	2.6	D
	Right Turn	111	115	103.5%	0.4	47.4	6.7	D
	Subtotal	492	488	99.1%	0.2	61.3	3.2	E
Total		1793	1776	99.0%	0.4	50.3	1.3	D

SimTraffic Post-Processor
Average Results from 20 Runs
Volume and Delay by Movement

Caltrain Electrification
Existing Conditions
PM Peak Hour

Intersection Pennsylvania Street/22nd Street

Unsignalized

Direction	Movement	Volume (veh/hr)			GEH	Total Delay (sec/veh)		
		Demand	Served	% Served		Average	Std. Dev.	LOS
NB	Left Turn	45	44	96.7%	0.2	7.0	0.5	A
	Through	178	174	97.9%	0.3	7.8	0.6	A
	Right Turn	38	35	92.6%	0.5	5.7	0.8	A
	Subtotal	261	253	96.9%	0.5	7.3	0.5	A
SB	Left Turn	11	10	86.4%	0.5	5.9	1.0	A
	Through	100	97	96.7%	0.3	6.5	0.4	A
	Right Turn	3	3	86.7%	0.2	3.8	1.6	A
	Subtotal	114	109	95.4%	0.5	6.4	0.4	A
EB	Left Turn	4	4	90.0%	0.2	4.8	1.4	A
	Through	30	31	103.3%	0.2	6.3	0.6	A
	Right Turn	67	70	104.3%	0.4	4.1	0.4	A
	Subtotal	101	105	103.5%	0.3	4.8	0.4	A
WB	Left Turn	102	105	102.9%	0.3	5.8	0.4	A
	Through	27	28	102.2%	0.1	6.0	0.5	A
	Right Turn	24	27	110.4%	0.5	4.0	0.4	A
	Subtotal	153	159	104.0%	0.5	5.5	0.4	A
Total		629	625	99.4%	0.1	6.3	0.3	A

Intersection Indiana Street/22nd Street

Unsignalized

Direction	Movement	Volume (veh/hr)			GEH	Total Delay (sec/veh)		
		Demand	Served	% Served		Average	Std. Dev.	LOS
NB	Left Turn	16	15	93.1%	0.3	5.3	0.8	A
	Through	60	60	99.8%	0.0	6.1	0.3	A
	Right Turn	49	49	100.0%	0.0	4.0	0.4	A
	Subtotal	125	124	99.0%	0.1	5.2	0.3	A
SB	Left Turn	8	7	90.0%	0.3	5.0	1.1	A
	Through	17	19	108.8%	0.4	5.8	0.5	A
	Right Turn	29	30	103.8%	0.2	3.9	0.4	A
	Subtotal	54	56	103.3%	0.2	4.7	0.3	A
EB	Left Turn	12	14	112.5%	0.4	4.4	0.4	A
	Through	70	66	93.9%	0.5	5.3	0.3	A
	Right Turn	10	10	103.0%	0.1	3.4	0.7	A
	Subtotal	92	90	97.3%	0.3	5.0	0.3	A
WB	Left Turn	7	6	85.7%	0.4	5.0	0.9	A
	Through	104	111	106.5%	0.7	5.5	0.3	A
	Right Turn	2	3	130.0%	0.4	3.2	1.8	A
	Subtotal	113	119	105.7%	0.6	5.4	0.3	A
Total		384	389	101.2%	0.2	5.1	0.2	A

SimTraffic Post-Processor
Average Results from 20 Runs
Volume and Delay by Movement

Caltrain Electrification
Existing Conditions
PM Peak Hour

Intersection

Tunnel Avenue/Blanken Avenue

Unsignalized

Direction	Movement	Volume (veh/hr)			GEH	Total Delay (sec/veh)		
		Demand	Served	% Served		Average	Std. Dev.	LOS
NB	Left Turn	24	25	102.5%	0.1	5.8	0.7	A
	Through	138	131	94.9%	0.6	7.6	0.5	A
	Right Turn	5	5	106.0%	0.1	3.9	1.1	A
	Subtotal	167	161	96.3%	0.5	7.2	0.4	A
SB	Left Turn	65	67	103.5%	0.3	5.1	0.3	A
	Through	52	52	100.8%	0.1	6.0	0.5	A
	Right Turn	8	9	115.0%	0.4	3.7	0.6	A
	Subtotal	125	129	103.1%	0.3	5.4	0.3	A
EB	Left Turn	3	3	83.3%	0.3	5.0	3.0	A
	Through	52	55	105.4%	0.4	6.1	0.5	A
	Right Turn	75	79	105.3%	0.5	3.8	0.4	A
	Subtotal	130	136	104.8%	0.5	4.7	0.5	A
WB	Left Turn	8	9	106.3%	0.2	6.3	1.2	A
	Through	119	118	99.3%	0.1	7.6	0.2	A
	Right Turn	73	70	95.3%	0.4	4.3	0.2	A
	Subtotal	200	196	98.2%	0.3	6.4	0.2	A
Total		622	622	100.1%	0.0	6.0	0.2	A

SimTraffic Post-Processor
Average Results from 20 Runs
Volume and Delay by Movement

Caltrain Electrification
Existing Conditions
PM Peak Hour

Intersection

Dubuque Way/Grand Avenue

Signalized

Direction	Movement	Volume (veh/hr)			GEH	Total Delay (sec/veh)		
		Demand	Served	% Served		Average	Std. Dev.	LOS
NB	Left Turn							
	Through							
	Right Turn							
	Subtotal							
SB	Left Turn	12	11	94.2%	0.2	42.4	12.7	D
	Through							
	Right Turn	47	47	99.8%	0.0	14.9	1.5	B
	Subtotal	59	58	98.6%	0.1	20.0	2.6	B
EB	Left Turn	23	24	103.0%	0.1	52.4	6.2	D
	Through	229	230	100.6%	0.1	3.2	0.7	A
	Right Turn							
	Subtotal	252	254	100.8%	0.1	7.7	1.0	A
WB	Left Turn							
	Through	1566	1562	99.7%	0.1	7.0	0.5	A
	Right Turn	56	54	96.6%	0.3	6.9	1.2	A
	Subtotal	1622	1616	99.6%	0.2	7.0	0.5	A
Total		1933	1928	99.7%	0.1	7.5	0.5	A

Intersection

Linden Avenue-San Mateo Avenue/San Mateo Avenue

Signalized

Direction	Movement	Volume (veh/hr)			GEH	Total Delay (sec/veh)		
		Demand	Served	% Served		Average	Std. Dev.	LOS
NB	Left Turn							
	Through	124	129	103.9%	0.4	6.6	1.0	A
	Right Turn	205	209	102.1%	0.3	1.4	0.2	A
	Subtotal	329	338	102.8%	0.5	3.4	0.4	A
SB	Left Turn	128	125	97.9%	0.2	13.2	1.0	B
	Through	127	129	101.6%	0.2	3.4	0.6	A
	Right Turn							
	Subtotal	255	254	99.7%	0.0	8.2	0.6	A
EB	Left Turn							
	Through							
	Right Turn							
	Subtotal							
WB	Left Turn	214	212	99.0%	0.1	13.4	0.8	B
	Through							
	Right Turn	156	154	98.8%	0.2	6.5	0.2	A
	Subtotal	370	366	98.9%	0.2	10.5	0.5	B
Total		954	958	100.5%	0.1	7.4	0.3	A

Intersection

Herman Street/Scott Street

Unsignalized

Direction	Movement	Volume (veh/hr)			GEH	Total Delay (sec/veh)		
		Demand	Served	% Served		Average	Std. Dev.	LOS
NB	Left Turn	5	4	72.0%	0.7	12.6	5.2	B
	Through	103	96	93.1%	0.7	11.1	0.7	B
	Right Turn	110	109	99.2%	0.1	7.5	0.9	A
	Subtotal	218	209	95.7%	0.6	9.2	0.9	A
SB	Left Turn	46	48	104.8%	0.3	13.3	1.5	B
	Through	151	154	101.9%	0.2	14.4	1.7	B
	Right Turn	7	7	105.7%	0.1	8.8	1.3	A
	Subtotal	204	209	102.6%	0.4	14.0	1.5	B
EB	Left Turn	2	2	75.0%	0.4	4.1	3.2	A
	Through	11	12	112.7%	0.4	9.3	1.2	A
	Right Turn	6	6	95.0%	0.1	6.0	3.1	A
	Subtotal	19	20	103.2%	0.1	8.0	1.1	A
WB	Left Turn	160	160	100.3%	0.0	0.2	0.0	A
	Through	19	23	118.9%	0.8	0.3	0.2	A
	Right Turn	26	28	109.2%	0.5	0.1	0.1	A
	Subtotal	205	211	103.1%	0.4	0.2	0.0	A
Total		646	649	100.5%	0.1	7.7	0.5	A

SimTraffic Post-Processor
Average Results from 20 Runs
Volume and Delay by Movement

Caltrain Electrification
Existing Conditions
PM Peak Hour

Intersection **Montgomery Avenue/Scott Street**

Unsignalized

Direction	Movement	Volume (veh/hr)			GEH	Total Delay (sec/veh)		
		Demand	Served	% Served		Average	Std. Dev.	LOS
NB	Left Turn	28	25	90.0%	0.5	7.0	1.3	A
	Through	3	3	110.0%	0.2	6.7	3.2	A
	Right Turn	17	18	104.7%	0.2	3.6	0.5	A
	Subtotal	48	46	96.5%	0.2	5.7	0.7	A
SB	Left Turn	7	9	121.4%	0.5	6.4	1.4	A
	Through	7	7	105.7%	0.1	7.4	0.9	A
	Right Turn	18	19	105.6%	0.2	3.5	0.6	A
	Subtotal	32	35	109.1%	0.5	5.0	0.4	A
EB	Left Turn	19	20	104.2%	0.2	2.4	0.5	A
	Through	124	124	99.8%	0.0	0.6	0.2	A
	Right Turn	24	26	108.3%	0.4	0.3	0.1	A
	Subtotal	167	170	101.6%	0.2	0.8	0.2	A
WB	Left Turn	11	10	90.0%	0.3	1.6	0.3	A
	Through	159	166	104.5%	0.6	0.4	0.1	A
	Right Turn	3	3	113.3%	0.2	0.1	0.1	A
	Subtotal	173	180	103.8%	0.5	0.5	0.2	A
Total		420	430	102.5%	0.5	1.5	0.2	A

Intersection **Driveway-Dollar Avenue/Linden Avenue**

Signalized

Direction	Movement	Volume (veh/hr)			GEH	Total Delay (sec/veh)		
		Demand	Served	% Served		Average	Std. Dev.	LOS
NB	Left Turn	80	80	100.1%	0.0	74.9	9.3	E
	Through							
	Right Turn	43	38	88.8%	0.8	61.0	10.2	E
	Subtotal	123	118	96.2%	0.4	70.2	8.1	E
SB	Left Turn							
	Through							
	Right Turn							
	Subtotal							
EB	Left Turn							
	Through	212	211	99.6%	0.1	87.7	8.8	F
	Right Turn	115	117	101.8%	0.2	71.1	9.6	E
	Subtotal	327	328	100.4%	0.1	81.8	8.8	F
WB	Left Turn	46	48	104.3%	0.3	3.6	2.4	A
	Through	234	243	104.0%	0.6	3.3	1.3	A
	Right Turn							
	Subtotal	280	291	104.0%	0.7	3.3	1.1	A
Total		730	738	101.1%	0.3	48.9	3.4	D

SimTraffic Post-Processor
Average Results from 20 Runs
Volume and Delay by Movement

Caltrain Electrification
Existing Conditions
PM Peak Hour

Intersection

San Mateo Avenue/San Bruno Avenue

Signalized

Direction	Movement	Volume (veh/hr)			GEH	Total Delay (sec/veh)		
		Demand	Served	% Served		Average	Std. Dev.	LOS
NB	Left Turn	20	17	86.0%	0.6	210.2	98.8	F
	Through	63	58	92.4%	0.6	127.7	69.4	F
	Right Turn	128	123	96.3%	0.4	61.8	52.8	E
	Subtotal	211	199	94.2%	0.9	94.4	59.9	F
SB	Left Turn	91	71	78.5%	2.2	424.4	205.8	F
	Through	83	70	84.5%	1.5	406.6	187.2	F
	Right Turn	95	70	73.2%	2.8	455.9	239.7	F
	Subtotal	269	211	78.4%	3.7	428.3	208.5	F
EB	Left Turn							
	Through	371	370	99.6%	0.1	3.6	0.4	A
	Right Turn							
	Subtotal	371	370	99.6%	0.1	3.6	0.4	A
WB	Left Turn	130	129	99.0%	0.1	104.0	53.1	F
	Through	544	540	99.3%	0.2	131.0	61.7	F
	Right Turn	54	54	99.4%	0.0	123.2	57.3	F
	Subtotal	728	722	99.2%	0.2	125.6	59.8	F
Total		1579	1502	95.1%	2.0	132.4	39.6	F

SimTraffic Post-Processor
Average Results from 20 Runs
Volume and Delay by Movement

Caltrain Electrification
Existing Conditions
PM Peak Hour

Intersection

El Camino Real/Millbrae Avenue

Signalized

Direction	Movement	Volume (veh/hr)			GEH	Total Delay (sec/veh)		
		Demand	Served	% Served		Average	Std. Dev.	LOS
NB	Left Turn	37	35	95.7%	0.3	73.1	5.0	E
	Through	665	695	104.5%	1.1	45.9	2.1	D
	Right Turn	368	366	99.5%	0.1	3.3	0.3	A
	Subtotal	1070	1096	102.5%	0.8	32.5	1.6	C
SB	Left Turn	620	613	98.9%	0.3	72.7	4.9	E
	Through	913	907	99.4%	0.2	34.5	2.1	C
	Right Turn	63	64	100.8%	0.1	34.8	4.1	C
	Subtotal	1596	1584	99.2%	0.3	49.3	3.1	D
EB	Left Turn	132	135	102.0%	0.2	75.5	5.4	E
	Through	278	276	99.2%	0.1	47.9	1.7	D
	Right Turn	35	35	100.0%	0.0	36.3	4.9	D
	Subtotal	445	445	100.1%	0.0	55.4	2.1	E
WB	Left Turn	602	598	99.4%	0.2	61.7	2.8	E
	Through	608	594	97.8%	0.6	45.7	2.7	D
	Right Turn	774	778	100.6%	0.2	19.2	2.4	B
	Subtotal	1984	1971	99.3%	0.3	40.1	1.1	D
Total		5095	5096	100.0%	0.0	42.7	1.0	D

Intersection

Rollins Road/Millbrae Avenue

Signalized

Direction	Movement	Volume (veh/hr)			GEH	Total Delay (sec/veh)		
		Demand	Served	% Served		Average	Std. Dev.	LOS
NB	Left Turn	318	320	100.5%	0.1	50.0	1.2	D
	Through	53	57	107.0%	0.5	47.3	5.8	D
	Right Turn	446	441	98.9%	0.2	28.2	2.0	C
	Subtotal	817	817	100.0%	0.0	38.0	1.5	D
SB	Left Turn	371	376	101.3%	0.3	44.0	1.8	D
	Through	47	45	94.9%	0.4	35.7	5.9	D
	Right Turn	135	139	103.2%	0.4	17.3	1.4	B
	Subtotal	553	560	101.2%	0.3	36.7	0.9	D
EB	Left Turn	79	80	101.3%	0.1	61.1	4.6	E
	Through	1049	1047	99.8%	0.1	37.8	1.9	D
	Right Turn	138	132	95.4%	0.6	16.2	1.3	B
	Subtotal	1266	1259	99.4%	0.2	37.1	1.6	D
WB	Left Turn	353	352	99.6%	0.1	62.6	2.4	E
	Through	1531	1521	99.3%	0.3	39.6	2.7	D
	Right Turn	172	175	101.6%	0.2	7.6	1.6	A
	Subtotal	2056	2047	99.6%	0.2	40.8	2.4	D
Total		4692	4683	99.8%	0.1	38.8	1.3	D

SimTraffic Post-Processor
Average Results from 20 Runs
Volume and Delay by Movement

Caltrain Electrification
Existing Conditions
PM Peak Hour

Intersection

California Drive/Oak Grove

Signalized

Direction	Movement	Volume (veh/hr)			GEH	Total Delay (sec/veh)		
		Demand	Served	% Served		Average	Std. Dev.	LOS
NB	Left Turn	33	35	106.4%	0.4	51.8	6.5	D
	Through	544	558	102.5%	0.6	22.2	1.3	C
	Right Turn	242	249	103.1%	0.5	8.9	2.2	A
	Subtotal	819	842	102.8%	0.8	19.5	1.4	B
SB	Left Turn	41	39	95.4%	0.3	59.0	8.1	E
	Through	680	678	99.8%	0.1	22.8	1.7	C
	Right Turn	55	55	99.5%	0.0	10.6	1.4	B
	Subtotal	776	772	99.5%	0.1	23.8	1.6	C
EB	Left Turn	28	25	87.5%	0.7	45.1	10.7	D
	Through	199	196	98.5%	0.2	45.2	6.7	D
	Right Turn	32	33	101.9%	0.1	31.4	7.5	C
	Subtotal	259	253	97.8%	0.4	43.4	6.7	D
WB	Left Turn	191	182	95.3%	0.7	24.8	1.7	C
	Through	115	115	99.8%	0.0	25.3	3.1	C
	Right Turn	101	99	97.9%	0.2	15.2	3.3	B
	Subtotal	407	396	97.2%	0.6	22.5	2.1	C
Total		2261	2263	100.1%	0.0	24.2	1.4	C

Intersection

Carolan Ave/Oak Grove

Unsignalized

Direction	Movement	Volume (veh/hr)			GEH	Total Delay (sec/veh)		
		Demand	Served	% Served		Average	Std. Dev.	LOS
NB	Left Turn	43	38	87.4%	0.9	48.7	10.2	E
	Through	87	93	106.4%	0.6	32.8	7.1	D
	Right Turn	42	48	114.5%	0.9	27.2	10.4	D
	Subtotal	172	178	103.7%	0.5	34.8	7.6	D
SB	Left Turn	20	17	83.5%	0.8	40.2	10.3	E
	Through	133	133	99.9%	0.0	36.1	9.9	E
	Right Turn	241	232	96.1%	0.6	71.4	32.5	F
	Subtotal	394	381	96.8%	0.6	57.9	21.9	F
EB	Left Turn	298	300	100.5%	0.1	0.5	0.2	A
	Through	122	133	109.2%	1.0	1.1	0.1	A
	Right Turn	62	64	103.2%	0.3	0.2	0.1	A
	Subtotal	482	497	103.0%	0.7	0.6	0.1	A
WB	Left Turn	47	46	98.7%	0.1	82.8	34.2	F
	Through	123	117	95.3%	0.5	96.0	35.1	F
	Right Turn	15	15	99.3%	0.0	88.8	43.8	F
	Subtotal	185	179	96.5%	0.5	92.1	35.2	F
Total		1233	1235	100.1%	0.1	36.6	11.5	E

Intersection **California Dr/North Lane**

Unsignalized

Direction	Movement	Volume (veh/hr)			GEH	Total Delay (sec/veh)		
		Demand	Served	% Served		Average	Std. Dev.	LOS
NB	Left Turn							
	Through	743	758	102.1%	0.6	1.1	0.2	A
	Right Turn	53	52	98.3%	0.1	2.9	1.0	A
	Subtotal	796	811	101.8%	0.5	1.2	0.2	A
SB	Left Turn	122	123	101.1%	0.1	17.3	2.9	C
	Through	706	704	99.7%	0.1	4.9	0.7	A
	Right Turn							
	Subtotal	828	828	99.9%	0.0	6.8	0.9	A
EB	Left Turn							
	Through							
	Right Turn							
	Subtotal							
WB	Left Turn	32	31	96.9%	0.2	34.2	6.5	D
	Through							
	Right Turn	124	128	103.2%	0.4	5.8	0.4	A
	Subtotal	156	159	101.9%	0.2	11.4	2.0	B
Total		1780	1797	101.0%	0.4	4.7	0.5	A

Intersection **Carolan Ave/North Lane**

Unsignalized

Direction	Movement	Volume (veh/hr)			GEH	Total Delay (sec/veh)		
		Demand	Served	% Served		Average	Std. Dev.	LOS
NB	Left Turn	87	89	102.2%	0.2	27.7	9.7	D
	Through	114	113	99.2%	0.1	10.6	2.9	B
	Right Turn	8	9	117.5%	0.5	9.3	14.3	A
	Subtotal	209	211	101.1%	0.2	17.8	6.3	C
SB	Left Turn	3	4	143.3%	0.7	8.4	2.3	A
	Through	154	160	103.6%	0.4	14.0	1.7	B
	Right Turn	69	69	99.6%	0.0	17.9	6.0	C
	Subtotal	226	233	102.9%	0.4	15.0	2.4	B
EB	Left Turn	58	55	95.3%	0.4	0.6	0.1	A
	Through	5	13	252.0%	2.6	0.8	0.4	A
	Right Turn	112	113	100.4%	0.0	0.4	0.1	A
	Subtotal	175	180	103.1%	0.4	0.5	0.1	A
WB	Left Turn							
	Through							
	Right Turn							
	Subtotal							
Total		610	624	102.3%	0.6	11.8	3.0	B

Intersection Anita Road/Peninsula Avenue

Unsignalized

Direction	Movement	Volume (veh/hr)			GEH	Total Delay (sec/veh)		
		Demand	Served	% Served		Average	Std. Dev.	LOS
NB	Left Turn							
	Through							
	Right Turn							
	Subtotal							
SB	Left Turn	17	18	107.6%	0.3	100.6	96.1	F
	Through							
	Right Turn	6	6	105.0%	0.1	199.1	108.1	F
	Subtotal	23	25	107.0%	0.3	124.5	97.3	F
EB	Left Turn	10	10	102.0%	0.1	17.3	5.4	C
	Through	602	593	98.5%	0.4	0.7	0.2	A
	Right Turn							
	Subtotal	612	603	98.6%	0.3	0.9	0.2	A
WB	Left Turn							
	Through	639	633	99.0%	0.2	35.0	4.6	D
	Right Turn	20	21	105.5%	0.2	29.1	7.5	D
	Subtotal	659	654	99.2%	0.2	34.8	4.6	D
Total		1294	1282	99.1%	0.3	20.6	3.1	C

Intersection Woodside Way/Villa Terrace

Unsignalized

Direction	Movement	Volume (veh/hr)			GEH	Total Delay (sec/veh)		
		Demand	Served	% Served		Average	Std. Dev.	LOS
NB	Left Turn	4	4	87.5%	0.3	4.3	0.4	A
	Through	12	14	115.8%	0.5	5.5	0.3	A
	Right Turn	6	5	86.7%	0.3	2.7	0.5	A
	Subtotal	22	23	102.7%	0.1	4.7	0.5	A
SB	Left Turn	10	11	108.0%	0.2	4.9	0.5	A
	Through	40	48	119.0%	1.1	5.6	0.6	A
	Right Turn	54	48	89.6%	0.8	3.3	0.2	A
	Subtotal	104	107	102.7%	0.3	4.5	0.3	A
EB	Left Turn	25	26	105.2%	0.3	2.9	0.2	A
	Through	28	30	106.4%	0.3	2.2	0.3	A
	Right Turn	12	15	125.0%	0.8	1.3	0.2	A
	Subtotal	65	71	109.4%	0.7	2.3	0.2	A
WB	Left Turn	3	3	86.7%	0.2	1.6	0.6	A
	Through	28	26	91.8%	0.4	0.6	0.1	A
	Right Turn	15	17	114.0%	0.5	0.2	0.1	A
	Subtotal	46	45	98.7%	0.1	0.5	0.1	A
Total		237	246	103.8%	0.6	3.1	0.2	A

SimTraffic Post-Processor
Average Results from 20 Runs
Volume and Delay by Movement

Caltrain Electrification
Existing Conditions
PM Peak Hour

Intersection N. San Mateo Drive/Villa Terrace

Unsignalized

Direction	Movement	Volume (veh/hr)			GEH	Total Delay (sec/veh)		
		Demand	Served	% Served		Average	Std. Dev.	LOS
NB	Left Turn	8	6	78.8%	0.6	4.6	1.6	A
	Through	555	544	98.0%	0.5	0.6	0.0	A
	Right Turn	40	43	107.8%	0.5	0.8	0.2	A
	Subtotal	603	594	98.4%	0.4	0.7	0.1	A
SB	Left Turn	17	19	110.0%	0.4	5.7	0.9	A
	Through	486	485	99.7%	0.1	1.9	0.1	A
	Right Turn	14	13	90.0%	0.4	1.6	0.5	A
	Subtotal	517	516	99.8%	0.1	2.0	0.1	A
EB	Left Turn	3	2	76.7%	0.4	11.2	5.2	B
	Through	8	8	105.0%	0.1	14.0	4.5	B
	Right Turn	13	13	99.2%	0.0	4.7	1.1	A
	Subtotal	24	24	98.3%	0.1	8.8	2.5	A
WB	Left Turn	35	31	88.3%	0.7	15.1	2.3	C
	Through	14	12	82.9%	0.7	19.4	6.4	C
	Right Turn	37	35	95.7%	0.3	8.6	1.4	A
	Subtotal	86	78	90.6%	0.9	12.8	2.1	B
Total		1230	1211	98.4%	0.5	2.2	0.2	A

Intersection Arundel Road/Peninsula Avenue

Unsignalized

Direction	Movement	Volume (veh/hr)			GEH	Total Delay (sec/veh)		
		Demand	Served	% Served		Average	Std. Dev.	LOS
NB	Left Turn	15	16	104.7%	0.2	575.6	279.8	F
	Through	7	7	95.7%	0.1	518.9	412.0	F
	Right Turn	30	26	87.0%	0.7	395.2	185.8	F
	Subtotal	52	49	93.3%	0.5	464.5	234.4	F
SB	Left Turn	11	12	110.9%	0.4	67.7	58.4	F
	Through	7	7	92.9%	0.2	67.8	53.5	F
	Right Turn	10	10	99.0%	0.0	103.6	84.4	F
	Subtotal	28	29	102.1%	0.1	82.4	69.7	F
EB	Left Turn	7	6	85.7%	0.4	14.3	10.6	B
	Through	560	554	98.9%	0.3	0.8	0.2	A
	Right Turn	52	50	95.8%	0.3	0.7	0.2	A
	Subtotal	619	609	98.4%	0.4	0.9	0.2	A
WB	Left Turn	54	51	94.6%	0.4	62.4	26.0	F
	Through	634	628	99.1%	0.2	59.6	24.7	F
	Right Turn	21	21	101.9%	0.1	51.5	21.9	F
	Subtotal	709	701	98.9%	0.3	59.5	24.6	F
Total		1408	1387	98.5%	0.6	47.0	12.5	E

Intersection **Railroad Ave/1st Ave**

Unsignalized

Direction	Movement	Volume (veh/hr)			GEH	Total Delay (sec/veh)		
		Demand	Served	% Served		Average	Std. Dev.	LOS
NB	Left Turn	12	13	107.5%	0.3	27.1	16.5	D
	Through	11	12	105.5%	0.2	16.3	8.4	C
	Right Turn	8	11	136.3%	0.9	11.3	8.0	B
	Subtotal	31	35	114.2%	0.8	19.0	9.5	C
SB	Left Turn							
	Through							
	Right Turn							
	Subtotal							
EB	Left Turn	5	6	116.0%	0.3	1.8	0.9	A
	Through	189	191	101.2%	0.2	0.3	0.1	A
	Right Turn							
	Subtotal	194	197	101.5%	0.2	0.4	0.1	A
WB	Left Turn							
	Through	139	139	100.2%	0.0	13.0	3.2	B
	Right Turn	3	4	133.3%	0.5	6.1	7.3	A
	Subtotal	142	143	100.9%	0.1	12.8	3.2	B
Total		367	376	102.4%	0.5	6.9	2.2	A

Intersection **S. B. St/1st Ave**

Signalized

Direction	Movement	Volume (veh/hr)			GEH	Total Delay (sec/veh)		
		Demand	Served	% Served		Average	Std. Dev.	LOS
NB	Left Turn	45	40	87.8%	0.8	28.1	5.8	C
	Through	215	211	98.3%	0.3	19.4	4.6	B
	Right Turn	60	61	102.0%	0.2	14.7	3.8	B
	Subtotal	320	312	97.5%	0.5	19.5	4.3	B
SB	Left Turn	62	64	103.2%	0.3	38.1	4.7	D
	Through	147	145	98.3%	0.2	28.6	6.0	C
	Right Turn	25	24	94.4%	0.3	24.4	9.3	C
	Subtotal	234	232	99.2%	0.1	30.7	5.5	C
EB	Left Turn	10	8	84.0%	0.5	75.5	21.1	E
	Through	70	69	98.3%	0.1	61.2	6.1	E
	Right Turn	32	34	106.3%	0.3	35.3	2.9	D
	Subtotal	112	111	99.3%	0.1	54.3	4.5	D
WB	Left Turn	22	22	98.6%	0.1	48.1	12.2	D
	Through	55	59	107.1%	0.5	44.9	5.6	D
	Right Turn	76	74	97.1%	0.3	23.9	5.2	C
	Subtotal	153	154	100.9%	0.1	35.1	4.2	D
Total		819	810	98.9%	0.3	30.5	2.5	C

SimTraffic Post-Processor
Average Results from 20 Runs
Volume and Delay by Movement

Caltrain Electrification
Existing Conditions
PM Peak Hour

Intersection

Transit Center Way/1st St

Unsignalized

Direction	Movement	Volume (veh/hr)			GEH	Total Delay (sec/veh)		
		Demand	Served	% Served		Average	Std. Dev.	LOS
NB	Left Turn	34	31	91.8%	0.5	33.7	18.7	D
	Through	8	8	97.5%	0.1	19.6	13.4	C
	Right Turn	33	33	98.8%	0.1	21.8	15.2	C
	Subtotal	75	72	95.5%	0.4	26.7	15.1	D
SB	Left Turn							
	Through							
	Right Turn							
	Subtotal							
EB	Left Turn	31	30	95.5%	0.3	4.5	1.9	A
	Through	161	170	105.8%	0.7	2.4	0.7	A
	Right Turn							
	Subtotal	192	200	104.1%	0.6	2.7	0.7	A
WB	Left Turn							
	Through	119	125	105.0%	0.5	9.3	2.1	A
	Right Turn	32	30	95.0%	0.3	4.0	3.1	A
	Subtotal	151	155	102.8%	0.3	8.2	2.1	A
Total		418	427	102.1%	0.4	8.8	3.6	A

SimTraffic Post-Processor
Average Results from 20 Runs
Volume and Delay by Movement

Caltrain Electrification
Existing Conditions
PM Peak Hour

Intersection **Railroad Avenue/9th Avenue**

Unsignalized

Direction	Movement	Volume (veh/hr)			GEH	Total Delay (sec/veh)		
		Demand	Served	% Served		Average	Std. Dev.	LOS
NB	Left Turn	34	31	89.7%	0.6	28.4	7.0	D
	Through							
	Right Turn	41	43	103.9%	0.2	16.6	9.2	C
	Subtotal	75	73	97.5%	0.2	21.4	8.2	C
SB	Left Turn							
	Through							
	Right Turn							
	Subtotal							
EB	Left Turn							
	Through	398	406	102.0%	0.4	0.7	0.1	A
	Right Turn	52	55	104.8%	0.3	0.1	0.0	A
	Subtotal	450	460	102.3%	0.5	0.6	0.1	A
WB	Left Turn	8	8	101.3%	0.0	9.0	2.2	A
	Through	385	391	101.5%	0.3	4.2	1.0	A
	Right Turn							
	Subtotal	393	399	101.5%	0.3	4.3	1.0	A
Total		918	932	101.6%	0.5	3.9	1.0	A

Intersection **S B Street/9th Avenue**

Signalized

Direction	Movement	Volume (veh/hr)			GEH	Total Delay (sec/veh)		
		Demand	Served	% Served		Average	Std. Dev.	LOS
NB	Left Turn	6	6	101.7%	0.0	16.1	6.7	B
	Through	94	96	101.8%	0.2	13.4	0.8	B
	Right Turn	138	135	98.1%	0.2	7.0	0.9	A
	Subtotal	238	237	99.7%	0.1	9.9	0.9	A
SB	Left Turn	87	86	99.0%	0.1	17.6	1.3	B
	Through	79	79	99.5%	0.0	10.5	1.9	B
	Right Turn	58	56	96.4%	0.3	4.8	1.1	A
	Subtotal	224	221	98.5%	0.2	11.8	1.0	B
EB	Left Turn	42	45	107.4%	0.5	32.0	10.9	C
	Through	225	240	106.7%	1.0	25.4	6.5	C
	Right Turn	10	11	114.0%	0.4	21.5	9.2	C
	Subtotal	277	297	107.0%	1.2	26.3	7.3	C
WB	Left Turn	87	86	98.9%	0.1	15.1	2.9	B
	Through	227	231	101.7%	0.3	10.0	1.1	A
	Right Turn	105	98	93.0%	0.7	5.5	1.4	A
	Subtotal	419	415	98.9%	0.2	10.0	1.3	A
Total		1158	1169	100.9%	0.3	14.4	1.7	B

SimTraffic Post-Processor
 Average Results from 20 Runs
 Volume and Delay by Movement

Caltrain Electrification
 Existing Conditions
 PM Peak Hour

Intersection

Concar Drive/SR 92 WB Ramps

Signalized

Direction	Movement	Volume (veh/hr)			GEH	Total Delay (sec/veh)		
		Demand	Served	% Served		Average	Std. Dev.	LOS
NB	Left Turn	14	12	82.9%	0.7	17.5	3.4	B
	Through	40	42	103.8%	0.2	18.0	2.4	B
	Right Turn							
	Subtotal	54	53	98.3%	0.1	18.0	1.6	B
SB	Left Turn	20	17	86.0%	0.6	20.4	2.3	C
	Through	44	46	104.1%	0.3	17.3	1.6	B
	Right Turn	4	4	92.5%	0.2	3.7	4.7	A
	Subtotal	68	67	98.1%	0.2	17.4	1.2	B
EB	Left Turn							
	Through	68	34	49.4%	4.8	24.0	3.1	C
	Right Turn	42	45	107.6%	0.5	8.5	2.5	A
	Subtotal	110	79	71.6%	3.2	15.1	2.8	B
WB	Left Turn	628	627	99.8%	0.0	3.3	0.5	A
	Through	88	60	68.2%	3.3	4.5	0.8	A
	Right Turn	41	54	131.0%	1.8	0.9	0.2	A
	Subtotal	757	741	97.8%	0.6	3.2	0.4	A
Total		989	939	95.0%	1.6	6.1	0.5	A

SimTraffic Post-Processor
Average Results from 20 Runs
Volume and Delay by Movement

Caltrain Electrification
Existing Conditions
PM Peak Hour

Intersection Delaware Ave/25th Ave

Signalized

Direction	Movement	Volume (veh/hr)			GEH	Total Delay (sec/veh)		
		Demand	Served	% Served		Average	Std. Dev.	LOS
NB	Left Turn	50	49	98.0%	0.1	30.2	12.0	C
	Through	8	9	111.3%	0.3	11.4	9.1	B
	Right Turn							
	Subtotal	58	58	99.8%	0.0	27.2	10.9	C
SB	Left Turn							
	Through	7	8	108.6%	0.2	12.3	9.8	B
	Right Turn	616	625	101.4%	0.3	6.2	3.2	A
	Subtotal	623	632	101.5%	0.4	6.3	3.1	A
EB	Left Turn	542	520	96.0%	0.9	37.4	2.0	D
	Through							
	Right Turn	30	29	96.7%	0.2	16.3	9.1	B
	Subtotal	572	549	96.0%	1.0	36.3	2.1	D
WB	Left Turn							
	Through							
	Right Turn							
	Subtotal							
Total		1253	1239	98.9%	0.4	20.6	2.4	C

Intersection El Camino Real/25th Ave

Unsignalized

Direction	Movement	Volume (veh/hr)			GEH	Total Delay (sec/veh)		
		Demand	Served	% Served		Average	Std. Dev.	LOS
NB	Left Turn	95	94	98.8%	0.1	63.7	5.2	F
	Through	1501	1515	100.9%	0.4	23.3	1.1	C
	Right Turn	313	321	102.5%	0.4	28.1	1.7	D
	Subtotal	1909	1930	101.1%	0.5	26.1	1.4	D
SB	Left Turn	126	123	97.9%	0.2	132.1	48.9	F
	Through	1281	1302	101.7%	0.6	20.5	1.4	C
	Right Turn	117	123	104.8%	0.5	22.2	1.7	C
	Subtotal	1524	1548	101.6%	0.6	29.7	5.4	D
EB	Left Turn	214	176	82.1%	2.7	648.6	85.7	F
	Through	133	102	76.8%	2.8	747.0	101.6	F
	Right Turn	51	40	77.6%	1.7	582.3	106.8	F
	Subtotal	398	318	79.8%	4.3	672.0	92.0	F
WB	Left Turn	374	376	100.6%	0.1	74.7	17.7	F
	Through	183	182	99.6%	0.1	90.4	16.6	F
	Right Turn	109	108	98.7%	0.1	51.9	12.4	F
	Subtotal	666	666	100.0%	0.0	75.3	16.5	F
Total		4497	4462	99.2%	0.5	80.6	4.5	F

SimTraffic Post-Processor
Average Results from 20 Runs
Volume and Delay by Movement

Caltrain Electrification
Existing Conditions
PM Peak Hour

Intersection El Camino Real/31st Street

Signalized

Direction	Movement	Volume (veh/hr)			GEH	Total Delay (sec/veh)		
		Demand	Served	% Served		Average	Std. Dev.	LOS
NB	Left Turn	150	150	100.1%	0.0	68.0	6.6	E
	Through	1479	1447	97.9%	0.8	26.2	1.1	C
	Right Turn	10	11	106.0%	0.2	1.9	0.5	A
	Subtotal	1639	1608	98.1%	0.8	29.9	1.2	C
SB	Left Turn	240	222	92.5%	1.2	365.3	154.9	F
	Through	1318	1300	98.6%	0.5	47.9	28.8	D
	Right Turn	63	60	94.6%	0.4	25.5	24.5	C
	Subtotal	1621	1582	97.6%	1.0	91.7	45.9	F
EB	Left Turn	253	252	99.5%	0.1	199.8	101.8	F
	Through	26	26	99.2%	0.0	224.5	113.7	F
	Right Turn	151	143	95.0%	0.6	19.1	21.0	B
	Subtotal	430	421	97.9%	0.4	139.9	75.2	F
WB	Left Turn	74	70	93.9%	0.5	40.1	4.3	D
	Through	27	29	107.4%	0.4	37.3	5.1	D
	Right Turn	13	13	100.0%	0.0	19.7	6.3	B
	Subtotal	114	112	97.8%	0.2	36.9	3.0	D
Total		3804	3722	97.9%	1.3	68.7	18.5	E

Intersection El Camino Real/Hillsdale Blvd

Signalized

Direction	Movement	Volume (veh/hr)			GEH	Total Delay (sec/veh)		
		Demand	Served	% Served		Average	Std. Dev.	LOS
NB	Left Turn							
	Through							
	Right Turn							
	Subtotal							
SB	Left Turn	390	373	95.5%	0.9	75.7	4.0	E
	Through							
	Right Turn	103	99	96.2%	0.4	6.7	0.6	A
	Subtotal	493	472	95.7%	1.0	61.2	3.6	E
EB	Left Turn							
	Through	553	545	98.6%	0.3	52.2	2.4	D
	Right Turn	125	127	101.7%	0.2	22.6	2.7	C
	Subtotal	678	672	99.1%	0.2	46.6	2.3	D
WB	Left Turn	320	316	98.8%	0.2	3.8	1.6	A
	Through	676	680	100.5%	0.1	2.7	0.9	A
	Right Turn							
	Subtotal	996	996	100.0%	0.0	3.0	0.8	A
Total		2908	2889	99.3%	0.4	67.1	1.7	E

SimTraffic Post-Processor
Average Results from 20 Runs
Volume and Delay by Movement

Caltrain Electrification
Existing Conditions
PM Peak Hour

Intersection **Curtiss Street/Hillsdale Blvd**

Signalized

Direction	Movement	Volume (veh/hr)			GEH	Total Delay (sec/veh)		
		Demand	Served	% Served		Average	Std. Dev.	LOS
NB	Left Turn	40	41	103.5%	0.2	31.0	3.9	C
	Through	20	21	105.5%	0.2	31.0	6.2	C
	Right Turn	56	58	103.8%	0.3	15.9	1.2	B
	Subtotal	116	121	104.0%	0.4	23.7	2.6	C
SB	Left Turn	32	35	108.1%	0.5	26.9	4.2	C
	Through	7	7	97.1%	0.1	24.9	9.1	C
	Right Turn	7	8	111.4%	0.3	20.2	7.7	C
	Subtotal	46	49	107.0%	0.5	25.6	3.4	C
EB	Left Turn							
	Through	1294	1295	100.1%	0.0	10.4	0.6	B
	Right Turn	49	47	95.9%	0.3	10.2	1.4	B
	Subtotal	1343	1342	99.9%	0.0	10.4	0.6	B
WB	Left Turn	5	4	84.0%	0.4	37.6	26.2	D
	Through	1247	1260	101.1%	0.4	17.8	16.3	B
	Right Turn	35	35	101.1%	0.1	15.6	14.4	B
	Subtotal	1287	1300	101.0%	0.4	17.8	16.3	B
Total		2792	2812	100.7%	0.4	14.7	7.7	B

SimTraffic Post-Processor
Average Results from 20 Runs
Volume and Delay by Movement

Caltrain Electrification
Existing Conditions
PM Peak Hour

Intersection

El Camino Real/Ralston Avenue

Signalized

Direction	Movement	Volume (veh/hr)			GEH	Total Delay (sec/veh)		
		Demand	Served	% Served		Average	Std. Dev.	LOS
NB	Left Turn	98	101	102.7%	0.3	104.4	19.1	F
	Through	954	983	103.0%	0.9	73.2	19.6	E
	Right Turn	225	234	103.9%	0.6	8.8	1.4	A
	Subtotal	1277	1317	103.1%	1.1	64.2	16.0	E
SB	Left Turn	246	227	92.4%	1.2	229.1	106.1	F
	Through	888	881	99.2%	0.2	52.0	29.7	D
	Right Turn	125	121	97.0%	0.3	28.3	27.2	C
	Subtotal	1259	1230	97.7%	0.8	82.8	43.7	F
EB	Left Turn	223	213	95.4%	0.7	157.0	65.2	F
	Through	575	566	98.5%	0.4	171.4	70.3	F
	Right Turn	78	78	99.9%	0.0	182.3	72.5	F
	Subtotal	876	857	97.8%	0.7	169.0	69.4	F
WB	Left Turn	259	252	97.1%	0.5	49.7	1.6	D
	Through	668	674	100.9%	0.2	68.7	5.7	E
	Right Turn	352	349	99.1%	0.2	30.5	6.1	C
	Subtotal	1279	1274	99.6%	0.1	54.6	2.9	D
Total		4691	4678	99.7%	0.2	85.4	11.9	F

SimTraffic Post-Processor
Average Results from 20 Runs
Volume and Delay by Movement

Caltrain Electrification
Existing Conditions
PM Peak Hour

Intersection

El Camino Real/San Carlos Avenue-Caltrain Station

Signalized

Direction	Movement	Volume (veh/hr)			GEH	Total Delay (sec/veh)		
		Demand	Served	% Served		Average	Std. Dev.	LOS
NB	Left Turn	218	220	101.0%	0.1	83.4	19.2	F
	Through	1051	1038	98.8%	0.4	71.9	27.9	E
	Right Turn	5	6	124.0%	0.5	82.1	31.7	F
	Subtotal	1274	1264	99.2%	0.3	74.0	25.9	E
SB	Left Turn	14	11	80.0%	0.8	67.7	12.9	E
	Through	932	930	99.7%	0.1	29.6	2.2	C
	Right Turn	402	406	101.0%	0.2	11.9	1.4	B
	Subtotal	1348	1347	99.9%	0.0	24.6	1.8	C
EB	Left Turn	381	369	96.8%	0.6	47.2	2.4	D
	Through	12	16	130.0%	1.0	36.3	4.3	D
	Right Turn	167	174	104.3%	0.5	27.8	2.3	C
	Subtotal	560	559	99.7%	0.1	40.8	1.9	D
WB	Left Turn	13	12	89.2%	0.4	63.5	11.8	E
	Through	24	20	83.8%	0.8	55.5	10.4	E
	Right Turn	27	26	96.7%	0.2	25.8	3.9	C
	Subtotal	64	58	90.3%	0.8	43.7	4.6	D
Total		3246	3227	99.4%	0.3	47.1	10.2	D

SimTraffic Post-Processor
Average Results from 20 Runs
Volume and Delay by Movement

Caltrain Electrification
Existing Conditions
PM Peak Hour

Intersection California/Broadway

Unsignalized

Direction	Movement	Volume (veh/hr)			GEH	Total Delay (sec/veh)		
		Demand	Served	% Served		Average	Std. Dev.	LOS
NB	Left Turn	12	10	83.3%	0.6	454.6	540.7	F
	Through	23	24	102.6%	0.1	544.8	808.8	F
	Right Turn	59	49	83.4%	1.3	482.2	550.1	F
	Subtotal	94	83	88.1%	1.2	493.0	613.8	F
SB	Left Turn	21	14	68.6%	1.6	836.4	856.3	F
	Through	28	21	76.1%	1.3	924.3	1243.5	F
	Right Turn	54	43	79.8%	1.6	713.8	916.8	F
	Subtotal	103	79	76.5%	2.5	777.8	961.1	F
EB	Left Turn	35	33	93.7%	0.4	65.5	29.6	F
	Through	180	168	93.2%	0.9	89.0	87.9	F
	Right Turn	50	45	90.4%	0.7	128.4	228.0	F
	Subtotal	265	246	92.7%	1.2	91.4	100.2	F
WB	Left Turn	94	81	85.9%	1.4	12.1	15.7	B
	Through	326	301	92.3%	1.4	4.3	3.2	A
	Right Turn	39	35	90.0%	0.6	0.2	0.1	A
	Subtotal	459	417	90.8%	2.0	5.4	5.1	A
Total		921	824	89.5%	3.3	130.0	121.1	F

Intersection Arguello Street/Brewster Ave

Signalized

Direction	Movement	Volume (veh/hr)			GEH	Total Delay (sec/veh)		
		Demand	Served	% Served		Average	Std. Dev.	LOS
NB	Left Turn	75	66	87.3%	1.1	97.0	38.6	F
	Through	144	136	94.7%	0.6	51.9	44.5	D
	Right Turn	40	42	106.0%	0.4	23.7	33.9	C
	Subtotal	259	244	94.3%	0.9	59.4	40.3	E
SB	Left Turn	20	19	97.0%	0.1	96.0	41.0	F
	Through	116	114	97.9%	0.2	81.1	82.5	F
	Right Turn	94	89	94.6%	0.5	76.2	82.4	E
	Subtotal	230	222	96.5%	0.5	80.4	78.5	F
EB	Left Turn	95	79	82.8%	1.7	7.4	2.8	A
	Through	193	175	90.8%	1.3	5.3	2.8	A
	Right Turn	30	27	89.7%	0.6	5.1	10.6	A
	Subtotal	318	281	88.3%	2.1	5.6	1.7	A
WB	Left Turn	20	21	104.5%	0.2	38.9	39.1	D
	Through	413	395	95.7%	0.9	30.1	12.6	C
	Right Turn	49	51	104.1%	0.3	21.2	6.6	C
	Subtotal	482	467	96.9%	0.7	29.5	11.5	C
Total		1289	1214	94.2%	2.1	39.4	24.7	D

Intersection El Camino Real/Broadway

Signalized

Direction	Movement	Volume (veh/hr)			GEH	Total Delay (sec/veh)		
		Demand	Served	% Served		Average	Std. Dev.	LOS
NB	Left Turn	160	158	98.5%	0.2	64.8	5.5	E
	Through	1240	1244	100.3%	0.1	37.8	9.6	D
	Right Turn	92	89	96.3%	0.4	69.3	142.5	E
	Subtotal	1492	1490	99.9%	0.0	41.5	12.1	D
SB	Left Turn	73	68	93.2%	0.6	119.0	183.7	F
	Through	1140	1162	101.9%	0.6	29.9	1.4	C
	Right Turn	15	15	100.0%	0.0	19.8	6.2	B
	Subtotal	1228	1245	101.4%	0.5	33.2	5.5	C
EB	Left Turn	11	10	87.3%	0.4	157.3	295.8	F
	Through	100	90	90.0%	1.0	164.6	361.3	F
	Right Turn	190	178	93.8%	0.9	112.1	270.3	F
	Subtotal	301	278	92.3%	1.4	130.4	299.8	F
WB	Left Turn	105	92	87.6%	1.3	69.8	12.1	E
	Through	190	180	94.6%	0.8	59.6	8.1	E
	Right Turn	97	83	85.5%	1.5	50.6	6.9	D
	Subtotal	392	355	90.5%	1.9	60.1	8.2	E
Total		3413	3368	98.7%	0.8	45.5	24.4	D

Intersection Arguello St/Broadway

Signalized

Direction	Movement	Volume (veh/hr)			GEH	Total Delay (sec/veh)		
		Demand	Served	% Served		Average	Std. Dev.	LOS
NB	Left Turn	25	21	82.8%	0.9	89.6	129.3	F
	Through	66	63	95.6%	0.4	54.4	48.3	D
	Right Turn	107	98	91.5%	0.9	39.0	30.5	D
	Subtotal	198	182	91.8%	1.2	48.2	39.7	D
SB	Left Turn	27	23	83.3%	0.9	78.2	94.6	E
	Through	79	77	98.0%	0.2	43.2	47.3	D
	Right Turn	60	56	93.0%	0.6	75.8	126.1	E
	Subtotal	166	156	93.8%	0.8	58.9	79.1	E
EB	Left Turn	95	84	88.2%	1.2	15.6	2.2	B
	Through	140	124	88.6%	1.4	9.7	4.0	A
	Right Turn	25	23	90.0%	0.5	1.1	0.6	A
	Subtotal	260	230	88.6%	1.9	11.0	3.0	B
WB	Left Turn	9	9	101.1%	0.0	62.5	27.5	E
	Through	374	343	91.6%	1.7	77.1	53.9	E
	Right Turn	98	96	98.2%	0.2	16.4	12.2	B
	Subtotal	481	448	93.1%	1.5	63.5	39.4	E
Total		1105	1016	91.9%	2.7	48.7	38.1	D

SimTraffic Post-Processor
Average Results from 20 Runs
Volume and Delay by Movement

Caltrain Electrification
Existing Conditions
PM Peak Hour

Intersection

El Camino Real/James

Signalized

Direction	Movement	Volume (veh/hr)			GEH	Total Delay (sec/veh)		
		Demand	Served	% Served		Average	Std. Dev.	LOS
NB	Left Turn	128	123	95.9%	0.5	77.1	15.8	E
	Through	1409	1323	93.9%	2.3	34.2	19.6	C
	Right Turn	38	35	92.9%	0.4	18.3	15.4	B
	Subtotal	1575	1481	94.0%	2.4	37.4	19.1	D
SB	Left Turn	119	111	93.4%	0.7	68.6	3.7	E
	Through	1314	1242	94.5%	2.0	21.2	1.6	C
	Right Turn	78	73	93.3%	0.6	12.7	2.8	B
	Subtotal	1511	1426	94.4%	2.2	24.5	1.5	C
EB	Left Turn	85	84	99.1%	0.1	77.6	13.4	E
	Through	55	53	96.7%	0.2	41.2	1.8	D
	Right Turn	95	89	94.0%	0.6	22.7	1.8	C
	Subtotal	235	227	96.5%	0.5	47.5	5.4	D
WB	Left Turn	116	93	80.0%	2.3	57.2	4.6	E
	Through	109	98	89.6%	1.1	54.9	10.9	D
	Right Turn	76	62	81.1%	1.7	37.5	7.6	D
	Subtotal	301	252	83.8%	2.9	51.5	2.6	D
Total		3622	3386	93.5%	4.0	33.7	8.7	C

Intersection El Camino Real/Atherton Avenue-Fair Oaks Lane

Signalized

Direction	Movement	Volume (veh/hr)			GEH	Total Delay (sec/veh)		
		Demand	Served	% Served		Average	Std. Dev.	LOS
NB	Left Turn	166	164	99.0%	0.1	49.3	2.5	D
	Through	1770	1772	100.1%	0.1	23.4	1.3	C
	Right Turn	70	72	102.9%	0.2	25.8	2.4	C
	Subtotal	2006	2009	100.1%	0.1	25.6	1.1	C
SB	Left Turn	36	34	95.6%	0.3	52.3	5.2	D
	Through	1075	1081	100.5%	0.2	25.6	1.7	C
	Right Turn	72	70	97.4%	0.2	26.0	3.5	C
	Subtotal	1183	1185	100.2%	0.1	26.4	1.8	C
EB	Left Turn	125	121	97.0%	0.3	48.1	3.6	D
	Through	89	85	96.0%	0.4	45.3	6.2	D
	Right Turn	61	60	98.4%	0.1	26.2	5.6	C
	Subtotal	275	267	96.9%	0.5	42.3	4.1	D
WB	Left Turn	37	29	78.6%	1.4	42.0	6.3	D
	Through	105	111	105.6%	0.6	41.8	2.6	D
	Right Turn	63	63	99.7%	0.0	19.9	3.4	B
	Subtotal	205	203	98.9%	0.2	35.0	1.1	C
Total		3669	3663	99.8%	0.1	27.6	1.1	C

Intersection El Camino Real/Watkins Avenue

Unsignalized

Direction	Movement	Volume (veh/hr)			GEH	Total Delay (sec/veh)		
		Demand	Served	% Served		Average	Std. Dev.	LOS
NB	Left Turn							
	Through	1908	1905	99.8%	0.1	2.1	0.1	A
	Right Turn	47	47	99.8%	0.0	3.0	0.3	A
	Subtotal	1955	1952	99.8%	0.1	2.1	0.1	A
SB	Left Turn	29	28	95.5%	0.2	21.5	3.6	C
	Through	1144	1141	99.7%	0.1	3.8	0.2	A
	Right Turn							
	Subtotal	1173	1168	99.6%	0.1	4.2	0.2	A
EB	Left Turn							
	Through							
	Right Turn							
	Subtotal							
WB	Left Turn	9	7	72.2%	0.9	107.6	88.7	F
	Through							
	Right Turn	98	96	98.4%	0.2	44.3	37.7	E
	Subtotal	107	103	96.2%	0.4	48.1	41.2	E
Total		3235	3223	99.6%	0.2	4.3	1.3	A

SimTraffic Post-Processor
Average Results from 20 Runs
Volume and Delay by Movement

Caltrain Electrification
Existing Conditions
PM Peak Hour

Intersection

El Camino Real/Glenwood

Signalized

Direction	Movement	Volume (veh/hr)			GEH	Total Delay (sec/veh)		
		Demand	Served	% Served		Average	Std. Dev.	LOS
NB	Left Turn	107	103	96.1%	0.4	75.2	7.9	E
	Through	1546	1501	97.1%	1.1	24.9	7.2	C
	Right Turn	37	34	93.0%	0.4	21.4	7.6	C
	Subtotal	1690	1638	96.9%	1.3	28.0	6.8	C
SB	Left Turn	38	36	95.3%	0.3	47.7	4.9	D
	Through	1000	989	98.9%	0.3	22.4	1.4	C
	Right Turn	242	247	102.2%	0.3	5.7	0.6	A
	Subtotal	1280	1273	99.4%	0.2	19.9	1.2	B
EB	Left Turn	315	308	97.9%	0.4	56.1	12.8	E
	Through	112	110	98.3%	0.2	61.7	16.1	E
	Right Turn	100	100	100.1%	0.0	22.1	10.7	C
	Subtotal	527	519	98.4%	0.4	50.7	13.1	D
WB	Left Turn	80	75	93.9%	0.6	42.0	4.1	D
	Through	161	157	97.4%	0.3	48.5	3.1	D
	Right Turn	25	28	113.2%	0.6	36.1	5.0	D
	Subtotal	266	260	97.8%	0.4	45.3	2.9	D
Total		3763	3690	98.1%	1.2	29.6	4.5	C

Intersection

El Camino Real/Oak Grove

Signalized

Direction	Movement	Volume (veh/hr)			GEH	Total Delay (sec/veh)		
		Demand	Served	% Served		Average	Std. Dev.	LOS
NB	Left Turn	109	108	99.3%	0.1	37.5	2.8	D
	Through	1487	1432	96.3%	1.4	22.1	2.1	C
	Right Turn	99	97	98.1%	0.2	12.0	1.2	B
	Subtotal	1695	1637	96.6%	1.4	22.6	2.0	C
SB	Left Turn	104	104	100.0%	0.0	43.1	4.8	D
	Through	986	967	98.1%	0.6	14.2	0.7	B
	Right Turn	90	92	102.7%	0.3	10.7	0.7	B
	Subtotal	1180	1164	98.6%	0.5	16.5	0.7	B
EB	Left Turn	118	119	101.1%	0.1	87.3	76.6	F
	Through	216	226	104.8%	0.7	94.3	82.2	F
	Right Turn	130	131	100.5%	0.1	65.2	80.4	E
	Subtotal	464	476	102.7%	0.6	84.6	80.5	F
WB	Left Turn	98	97	99.2%	0.1	45.9	4.1	D
	Through	181	181	100.1%	0.0	45.4	2.8	D
	Right Turn	85	87	102.7%	0.2	21.2	2.9	C
	Subtotal	364	366	100.5%	0.1	39.7	2.7	D
Total		3703	3643	98.4%	1.0	30.9	11.0	C

Intersection

El Camino Real/Santa Cruz Ave

Signalized

Direction	Movement	Volume (veh/hr)			GEH	Total Delay (sec/veh)		
		Demand	Served	% Served		Average	Std. Dev.	LOS
NB	Left Turn							
	Through	1475	1434	97.2%	1.1	10.1	2.6	B
	Right Turn	75	69	92.5%	0.7	5.4	1.1	A
	Subtotal	1550	1504	97.0%	1.2	9.9	2.5	A
SB	Left Turn							
	Through	1117	1102	98.6%	0.5	4.2	1.1	A
	Right Turn	97	94	96.4%	0.4	3.0	0.4	A
	Subtotal	1214	1195	98.5%	0.5	4.1	1.0	A
EB	Left Turn	170	162	95.5%	0.6	46.1	9.3	D
	Through	68	67	98.2%	0.1	37.4	3.0	D
	Right Turn	164	165	100.6%	0.1	23.0	3.9	C
	Subtotal	402	394	98.0%	0.4	35.0	5.3	C
WB	Left Turn	70	65	92.6%	0.6	42.0	2.7	D
	Through	61	54	89.2%	0.9	50.2	6.4	D
	Right Turn	50	46	92.0%	0.6	40.6	6.0	D
	Subtotal	181	165	91.3%	1.2	44.3	3.9	D
Total		3347	3258	97.3%	1.5	12.5	1.5	B

Intersection

Merril St/Santa Cruz Ave

Unsignalized

Direction	Movement	Volume (veh/hr)			GEH	Total Delay (sec/veh)		
		Demand	Served	% Served		Average	Std. Dev.	LOS
NB	Left Turn	60	51	84.5%	1.3	8.8	1.5	A
	Through	13	14	106.2%	0.2	9.4	3.4	A
	Right Turn							
	Subtotal	73	65	88.4%	1.0	8.9	1.7	A
SB	Left Turn	4	4	105.0%	0.1	9.0	2.3	A
	Through	4	4	105.0%	0.1	10.5	2.7	B
	Right Turn	106	98	92.5%	0.8	5.5	0.6	A
	Subtotal	114	107	93.4%	0.7	5.8	0.5	A
EB	Left Turn	100	94	94.4%	0.6	7.1	0.5	A
	Through	20	19	94.5%	0.2	9.3	1.2	A
	Right Turn	23	24	102.6%	0.1	5.3	1.0	A
	Subtotal	143	137	95.7%	0.5	7.1	0.4	A
WB	Left Turn							
	Through	15	15	102.7%	0.1	5.4	1.9	A
	Right Turn	12	14	113.3%	0.4	5.4	1.5	A
	Subtotal	27	29	107.4%	0.4	5.3	0.9	A
Total		357	337	94.4%	1.1	6.9	0.4	A

SimTraffic Post-Processor
Average Results from 20 Runs
Volume and Delay by Movement

Caltrain Electrification
Existing Conditions
PM Peak Hour

Intersection

Ravenswood Ave/Laurel St

Signalized

Direction	Movement	Volume (veh/hr)			GEH	Total Delay (sec/veh)		
		Demand	Served	% Served		Average	Std. Dev.	LOS
NB	Left Turn	199	185	92.9%	1.0	43.3	4.4	D
	Through	140	129	92.2%	0.9	27.5	3.0	C
	Right Turn	44	40	90.9%	0.6	23.3	3.0	C
	Subtotal	383	354	92.4%	1.5	35.3	3.7	D
SB	Left Turn	58	54	92.2%	0.6	36.8	3.6	D
	Through	134	131	97.5%	0.3	34.2	2.4	C
	Right Turn	51	47	92.2%	0.6	26.4	2.8	C
	Subtotal	243	231	95.1%	0.8	33.2	2.7	C
EB	Left Turn	74	63	84.7%	1.4	37.5	5.8	D
	Through	879	807	91.8%	2.5	27.2	2.0	C
	Right Turn	126	113	89.8%	1.2	24.9	4.1	C
	Subtotal	1079	983	91.1%	3.0	27.6	1.9	C
WB	Left Turn	32	30	93.1%	0.4	62.3	15.5	E
	Through	565	553	97.8%	0.5	14.2	1.0	B
	Right Turn	39	38	96.2%	0.2	11.5	1.3	B
	Subtotal	636	620	97.5%	0.6	16.4	1.5	B
Total		2341	2187	93.4%	3.2	26.3	1.5	C

SimTraffic Post-Processor
Average Results from 20 Runs
Volume and Delay by Movement

Caltrain Electrification
Existing Conditions
PM Peak Hour

Intersection

High Street/University Ave

Signalized

Direction	Movement	Volume (veh/hr)			GEH	Total Delay (sec/veh)		
		Demand	Served	% Served		Average	Std. Dev.	LOS
NB	Left Turn							
	Through							
	Right Turn							
	Subtotal							
SB	Left Turn	14	13	95.0%	0.2	21.5	5.6	C
	Through	65	66	100.9%	0.1	14.7	2.6	B
	Right Turn	155	152	98.0%	0.3	9.5	1.1	A
	Subtotal	234	231	98.6%	0.2	11.7	1.1	B
EB	Left Turn							
	Through	587	580	98.7%	0.3	15.4	0.9	B
	Right Turn	396	409	103.2%	0.6	5.3	0.7	A
	Subtotal	983	988	100.5%	0.2	11.2	0.6	B
WB	Left Turn	27	24	89.3%	0.6	35.7	6.3	D
	Through	409	422	103.2%	0.6	21.0	2.4	C
	Right Turn							
	Subtotal	436	446	102.3%	0.5	21.8	2.6	C
Total		1653	1665	100.7%	0.3	14.1	0.9	B

SimTraffic Post-Processor
 Average Results from 20 Runs
 Volume and Delay by Movement

Caltrain Electrification
 Existing Conditions
 PM Peak Hour

Intersection

Showers Drive/Pacchetti Way

Signalized

Direction	Movement	Volume (veh/hr)			GEH	Total Delay (sec/veh)		
		Demand	Served	% Served		Average	Std. Dev.	LOS
NB	Left Turn	3	2	53.3%	0.9	19.2	13.9	B
	Through	19	19	101.6%	0.1	2.5	0.9	A
	Right Turn							
	Subtotal	22	21	95.0%	0.2	4.4	1.6	A
SB	Left Turn							
	Through	168	165	98.3%	0.2	3.7	0.4	A
	Right Turn	40	41	101.3%	0.1	1.4	0.4	A
	Subtotal	208	206	98.8%	0.2	3.2	0.4	A
EB	Left Turn	10	8	81.0%	0.6	13.4	3.9	B
	Through							
	Right Turn	9	8	93.3%	0.2	3.1	0.9	A
	Subtotal	19	17	86.8%	0.6	8.1	2.0	A
WB	Left Turn							
	Through							
	Right Turn							
	Subtotal							
Total		249	243	97.6%	0.4	3.7	0.4	A

Intersection Hope Street/Evelyn Ave

Signalized

Direction	Movement	Volume (veh/hr)			GEH	Total Delay (sec/veh)		
		Demand	Served	% Served		Average	Std. Dev.	LOS
NB	Left Turn	46	44	96.5%	0.2	15.0	1.8	B
	Through							
	Right Turn	140	147	104.8%	0.6	4.8	0.3	A
	Subtotal	186	191	102.7%	0.4	7.2	0.6	A
SB	Left Turn							
	Through							
	Right Turn							
	Subtotal							
EB	Left Turn							
	Through	34	34	100.0%	0.0	2.2	0.5	A
	Right Turn	17	17	97.1%	0.1	0.8	0.3	A
	Subtotal	51	51	99.0%	0.1	1.7	0.2	A
WB	Left Turn	69	67	97.5%	0.2	2.0	0.6	A
	Through	167	163	97.7%	0.3	1.8	0.2	A
	Right Turn							
	Subtotal	236	230	97.6%	0.4	1.9	0.2	A
Total		473	472	99.8%	0.0	4.0	0.2	A

Intersection 229 Castro Street/Villa Street

Signalized

Direction	Movement	Volume (veh/hr)			GEH	Total Delay (sec/veh)		
		Demand	Served	% Served		Average	Std. Dev.	LOS
NB	Left Turn	34	29	85.6%	0.9	29.6	3.9	C
	Through	248	244	98.4%	0.3	22.1	0.8	C
	Right Turn	37	37	100.0%	0.0	14.3	2.2	B
	Subtotal	319	310	97.2%	0.5	21.8	0.7	C
SB	Left Turn	202	206	102.0%	0.3	28.5	1.3	C
	Through	239	252	105.3%	0.8	10.2	0.8	B
	Right Turn	63	67	105.9%	0.5	7.3	1.2	A
	Subtotal	504	524	104.0%	0.9	17.0	0.6	B
EB	Left Turn	62	61	98.7%	0.1	32.7	3.5	C
	Through	191	195	102.1%	0.3	26.5	2.6	C
	Right Turn	32	34	104.7%	0.3	21.4	5.8	C
	Subtotal	285	290	101.6%	0.3	27.3	2.8	C
WB	Left Turn	22	21	94.1%	0.3	31.4	4.9	C
	Through	186	192	103.3%	0.4	23.0	2.6	C
	Right Turn	59	58	98.3%	0.1	16.7	3.4	B
	Subtotal	267	271	101.4%	0.2	22.3	2.8	C
Total		1375	1395	101.4%	0.5	21.2	0.7	C

SimTraffic Post-Processor
Average Results from 20 Runs
Volume and Delay by Movement

Caltrain Electrification
Existing Conditions
PM Peak Hour

Intersection

Frances St/Evelyn Ave

Signalized

Direction	Movement	Volume (veh/hr)			GEH	Total Delay (sec/veh)		
		Demand	Served	% Served		Average	Std. Dev.	LOS
NB	Left Turn	24	28	114.6%	0.7	45.9	5.9	D
	Through	14	14	99.3%	0.0	40.7	8.0	D
	Right Turn	17	17	100.6%	0.0	22.0	6.6	C
	Subtotal	55	59	106.4%	0.5	37.7	5.4	D
SB	Left Turn	71	70	99.0%	0.1	53.9	5.3	D
	Through	16	18	110.6%	0.4	50.7	8.1	D
	Right Turn	44	52	117.0%	1.1	29.6	3.9	C
	Subtotal	131	140	106.5%	0.7	44.5	3.8	D
EB	Left Turn	36	33	92.5%	0.5	89.3	15.9	F
	Through	471	474	100.7%	0.1	18.3	1.2	B
	Right Turn	68	70	103.4%	0.3	16.3	1.3	B
	Subtotal	575	578	100.5%	0.1	22.2	1.7	C
WB	Left Turn	73	70	95.6%	0.4	69.7	4.5	E
	Through	339	360	106.1%	1.1	9.8	0.6	A
	Right Turn	69	72	104.3%	0.4	3.4	0.9	A
	Subtotal	481	502	104.3%	0.9	17.2	0.9	B
Total		1242	1277	102.8%	1.0	23.4	0.7	C

SimTraffic Post-Processor
Average Results from 20 Runs
Volume and Delay by Movement

Caltrain Electrification
Existing Conditions
PM Peak Hour

Intersection Lawrence Expressway/Kifer Road

Signalized

Direction	Movement	Volume (veh/hr)			GEH	Total Delay (sec/veh)		
		Demand	Served	% Served		Average	Std. Dev.	LOS
NB	Left Turn	84	86	102.1%	0.2	71.3	8.0	E
	Through	1674	1649	98.5%	0.6	76.1	1.2	E
	Right Turn	245	242	98.6%	0.2	84.2	2.4	F
	Subtotal	2003	1976	98.7%	0.6	76.9	1.2	E
SB	Left Turn	387	377	97.4%	0.5	223.1	56.2	F
	Through	3068	3078	100.3%	0.2	63.9	11.8	E
	Right Turn	45	43	95.8%	0.3	73.8	15.6	E
	Subtotal	3500	3498	99.9%	0.0	81.3	14.8	F
EB	Left Turn	276	175	63.2%	6.8	51.2	4.1	D
	Through	534	354	66.4%	8.5	90.7	8.5	F
	Right Turn	1078	693	64.3%	12.9	262.9	4.1	F
	Subtotal	1888	1222	64.7%	16.9	182.8	3.4	F
WB	Left Turn	599	367	61.3%	10.6	302.6	155.0	F
	Through	892	507	56.9%	14.5	533.3	6.3	F
	Right Turn	189	106	56.2%	6.8	529.9	16.4	F
	Subtotal	1680	981	58.4%	19.2	447.6	59.8	F
Total		9071	7677	84.6%	15.2	143.1	11.0	F

Intersection Lawrence Expressway/Reed Ave-Monroe St

Signalized

Direction	Movement	Volume (veh/hr)			GEH	Total Delay (sec/veh)		
		Demand	Served	% Served		Average	Std. Dev.	LOS
NB	Left Turn	132	137	103.8%	0.4	113.5	32.8	F
	Through	1674	1670	99.8%	0.1	35.4	1.1	D
	Right Turn	342	339	99.1%	0.2	14.1	1.7	B
	Subtotal	2148	2146	99.9%	0.0	37.2	2.5	D
SB	Left Turn	603	521	86.4%	3.5	124.3	15.7	F
	Through	3806	3322	87.3%	8.1	45.3	2.5	D
	Right Turn	336	301	89.5%	2.0	30.1	2.4	C
	Subtotal	4745	4144	87.3%	9.0	54.2	2.8	D
EB	Left Turn	252	232	92.1%	1.3	230.8	82.8	F
	Through	553	489	88.4%	2.8	357.6	116.2	F
	Right Turn	362	329	90.9%	1.8	184.2	102.7	F
	Subtotal	1167	1050	89.9%	3.5	275.3	104.6	F
WB	Left Turn	342	321	93.9%	1.1	304.4	89.7	F
	Through	297	287	96.5%	0.6	207.8	69.4	F
	Right Turn	77	74	96.1%	0.3	42.2	37.9	D
	Subtotal	716	682	95.2%	1.3	235.6	75.0	F
Total		8776	8022	91.4%	8.2	93.7	14.8	F

SimTraffic Post-Processor
Average Results from 20 Runs
Volume and Delay by Movement

Caltrain Electrification
Existing Conditions
PM Peak Hour

Intersection

El Camino Real/Railroad Avenue

Signalized

Direction	Movement	Volume (veh/hr)			GEH	Total Delay (sec/veh)		
		Demand	Served	% Served		Average	Std. Dev.	LOS
NB	Left Turn	167	0	0.0%	18.3	0.0	0.0	A
	Through	659	848	128.7%	6.9	22.0	1.0	C
	Right Turn	18	0	0.0%	6.0	0.0	0.0	A
	Subtotal	844	848	100.5%	0.1	22.0	1.0	C
SB	Left Turn	66	0	0.0%	11.5	0.0	0.0	A
	Through	1121	1356	120.9%	6.7	16.7	0.6	B
	Right Turn	156	0	0.0%	17.7	0.0	0.0	A
	Subtotal	1343	1356	100.9%	0.3	16.7	0.6	B
EB	Left Turn	54	0	0.0%	10.4	0.0	0.0	A
	Through	2	178	8875.0%	18.5	31.5	3.3	C
	Right Turn	116	0	0.0%	15.2	0.0	0.0	A
	Subtotal	172	178	103.2%	0.4	31.5	3.3	C
WB	Left Turn	65	0	0.0%	11.4	0.0	0.0	A
	Through	8	98	1227.5%	12.4	60.2	5.1	E
	Right Turn	23	0	0.0%	6.8	0.0	0.0	A
	Subtotal	96	98	102.3%	0.2	60.2	5.1	E
Total		2455	2480	101.0%	0.5	21.3	0.4	C

SimTraffic Post-Processor
Average Results from 20 Runs
Volume and Delay by Movement

Caltrain Electrification
Existing Conditions
PM Peak Hour

Intersection Santa Clara Street/Cahill Street

Signalized

Direction	Movement	Volume (veh/hr)			GEH	Total Delay (sec/veh)		
		Demand	Served	% Served		Average	Std. Dev.	LOS
NB	Left Turn	94	99	104.9%	0.5	28.7	2.5	C
	Through							
	Right Turn	98	97	98.9%	0.1	12.9	0.8	B
	Subtotal	192	196	101.8%	0.3	20.9	1.9	C
SB	Left Turn							
	Through							
	Right Turn	2	2	95.0%	0.1	3.5	1.5	A
	Subtotal	2	2	95.0%	0.1	3.5	1.5	A
EB	Left Turn							
	Through	1015	1045	103.0%	0.9	15.3	0.7	B
	Right Turn	76	80	105.1%	0.4	14.8	1.0	B
	Subtotal	1091	1125	103.1%	1.0	15.2	0.7	B
WB	Left Turn	105	106	101.1%	0.1	31.5	2.8	C
	Through	647	669	103.4%	0.9	3.2	0.4	A
	Right Turn	9	9	96.7%	0.1	1.2	0.8	A
	Subtotal	761	784	103.0%	0.8	7.0	0.6	A
Total		2046	2107	103.0%	1.3	12.7	0.6	B

Intersection San Fernando Street/Montgomery Street

Signalized

Direction	Movement	Volume (veh/hr)			GEH	Total Delay (sec/veh)		
		Demand	Served	% Served		Average	Std. Dev.	LOS
NB	Left Turn							
	Through							
	Right Turn							
	Subtotal							
SB	Left Turn	48	47	98.5%	0.1	10.1	1.0	B
	Through	682	709	103.9%	1.0	8.5	0.4	A
	Right Turn	16	18	111.3%	0.4	7.9	2.3	A
	Subtotal	746	774	103.7%	1.0	8.6	0.4	A
EB	Left Turn							
	Through	70	79	112.4%	1.0	9.9	1.0	A
	Right Turn	96	97	101.5%	0.1	4.9	0.7	A
	Subtotal	166	176	106.1%	0.8	7.1	0.9	A
WB	Left Turn	106	114	107.1%	0.7	15.8	0.9	B
	Through	109	122	111.9%	1.2	13.3	1.2	B
	Right Turn							
	Subtotal	215	236	109.5%	1.4	14.5	0.9	B
Total		1127	1186	105.2%	1.7	9.6	0.4	A

SimTraffic Post-Processor
Average Results from 20 Runs
Volume and Delay by Movement

Caltrain Electrification
Existing Conditions
PM Peak Hour

Intersection

Lick Avenue-Shadow Run Drive/Alma Avenue

Signalized

Direction	Movement	Volume (veh/hr)			GEH	Total Delay (sec/veh)		
		Demand	Served	% Served		Average	Std. Dev.	LOS
NB	Left Turn	20	17	85.5%	0.7	44.3	6.8	D
	Through	2	2	85.0%	0.2	37.8	28.9	D
	Right Turn	7	6	85.7%	0.4	5.5	3.1	A
	Subtotal	29	25	85.5%	0.8	34.6	5.3	C
SB	Left Turn	166	167	100.6%	0.1	47.8	1.9	D
	Through	7	8	112.9%	0.3	26.1	12.6	C
	Right Turn	54	53	97.8%	0.2	6.4	1.8	A
	Subtotal	227	228	100.3%	0.0	37.4	2.3	D
EB	Left Turn	50	46	92.2%	0.6	47.4	3.7	D
	Through	486	497	102.2%	0.5	15.7	0.6	B
	Right Turn	36	37	102.2%	0.1	13.1	1.9	B
	Subtotal	572	580	101.3%	0.3	18.0	0.8	B
WB	Left Turn	10	8	81.0%	0.6	43.1	14.5	D
	Through	558	565	101.2%	0.3	16.7	0.7	B
	Right Turn	51	51	100.6%	0.0	14.2	2.5	B
	Subtotal	619	624	100.8%	0.2	16.8	0.7	B
Total		1447	1456	100.6%	0.2	20.8	0.7	C

SimTraffic Post-Processor
Average Results from 20 Runs
Volume and Delay by Movement

Caltrain Electrification
Existing Conditions
PM Peak Hour

Intersection 7th Street/Mission Bay

Signalized

Direction	Movement	Volume (veh/hr)			GEH	Total Delay (sec/veh)		
		Demand	Served	% Served		Average	Std. Dev.	LOS
NB	Left Turn							
	Through	875	873	99.8%	0.1	7.4	0.5	A
	Right Turn	52	51	98.5%	0.1	20.1	2.8	C
	Subtotal	927	924	99.7%	0.1	8.1	0.6	A
SB	Left Turn	80	81	101.1%	0.1	99.9	6.9	F
	Through	224	220	98.0%	0.3	4.0	1.1	A
	Right Turn	2	2	90.0%	0.1	0.8	1.6	A
	Subtotal	306	302	98.8%	0.2	29.7	2.1	C
EB	Left Turn							
	Through							
	Right Turn							
	Subtotal							
WB	Left Turn	24	22	90.0%	0.5	3.5	3.1	A
	Through							
	Right Turn	59	58	97.8%	0.2	0.6	0.1	A
	Subtotal	83	79	95.5%	0.4	1.5	0.9	A
Total		1316	1306	99.2%	0.3	12.7	0.6	B

Intersection Berry Street/Mission Bay

Signalized

Direction	Movement	Volume (veh/hr)			GEH	Total Delay (sec/veh)		
		Demand	Served	% Served		Average	Std. Dev.	LOS
NB	Left Turn							
	Through							
	Right Turn							
	Subtotal							
SB	Left Turn							
	Through							
	Right Turn	83	81	97.7%	0.2	21.2	3.9	C
	Subtotal	83	81	97.7%	0.2	21.2	3.9	C
EB	Left Turn	132	132	99.8%	0.0	0.5	0.2	A
	Through							
	Right Turn							
	Subtotal	132	132	99.8%	0.0	0.5	0.2	A
WB	Left Turn							
	Through							
	Right Turn							
	Subtotal							
Total		215	213	99.0%	0.1	8.4	1.9	A

Intersection Main Street/Maple Street

Unsignalized

Direction	Movement	Volume (veh/hr)			GEH	Total Delay (sec/veh)		
		Demand	Served	% Served		Average	Std. Dev.	LOS
NB	Left Turn							
	Through	463	479	103.5%	0.7	4.9	1.0	A
	Right Turn							
	Subtotal	463	479	103.5%	0.7	4.9	1.0	A
SB	Left Turn							
	Through	455	450	98.9%	0.2	11.4	0.7	B
	Right Turn							
	Subtotal	455	450	98.9%	0.2	11.4	0.7	B
EB	Left Turn							
	Through							
	Right Turn							
	Subtotal							
WB	Left Turn							
	Through							
	Right Turn	5	4	70.0%	0.7	14.3	11.7	B
	Subtotal	5	4	70.0%	0.7	14.3	11.7	B
Total		923	932	101.0%	0.3	8.1	0.5	A

Intersection Main Street/Beech Street

Unsignalized

Direction	Movement	Volume (veh/hr)			GEH	Total Delay (sec/veh)		
		Demand	Served	% Served		Average	Std. Dev.	LOS
NB	Left Turn	62	60	96.6%	0.3	3.4	0.4	A
	Through	278	280	100.8%	0.1	1.1	0.3	A
	Right Turn							
	Subtotal	340	340	100.0%	0.0	1.5	0.3	A
SB	Left Turn							
	Through	278	291	104.5%	0.7	0.5	0.1	A
	Right Turn	8	9	111.3%	0.3	0.3	0.3	A
	Subtotal	286	300	104.7%	0.8	0.5	0.1	A
EB	Left Turn	49	46	94.1%	0.4	10.0	1.2	A
	Through							
	Right Turn	16	15	95.0%	0.2	4.5	0.8	A
	Subtotal	65	61	94.3%	0.5	8.6	1.0	A
WB	Left Turn							
	Through							
	Right Turn							
	Subtotal							
Total		691	701	101.4%	0.4	1.7	0.2	A

SimTraffic Post-Processor
Average Results from 20 Runs
Volume and Delay by Movement

Caltrain Electrification
Existing Conditions
PM Peak Hour

Intersection Main Street/Middlefield Road

Signalized

Direction	Movement	Volume (veh/hr)			GEH	Total Delay (sec/veh)		
		Demand	Served	% Served		Average	Std. Dev.	LOS
NB	Left Turn	50	47	93.4%	0.5	56.1	3.6	E
	Through	390	410	105.0%	1.0	21.6	1.1	C
	Right Turn	28	26	93.2%	0.4	7.8	3.9	A
	Subtotal	468	482	103.1%	0.7	24.2	0.8	C
SB	Left Turn	41	39	95.6%	0.3	48.4	8.3	D
	Through	359	349	97.3%	0.5	28.3	2.6	C
	Right Turn	58	60	102.6%	0.2	6.1	1.1	A
	Subtotal	458	448	97.8%	0.5	27.1	2.1	C
EB	Left Turn	87	85	97.8%	0.2	40.1	5.5	D
	Through	247	248	100.4%	0.1	21.9	2.5	C
	Right Turn	50	51	102.2%	0.2	15.8	2.5	B
	Subtotal	384	384	100.0%	0.0	25.1	2.9	C
WB	Left Turn	46	46	100.0%	0.0	10.4	2.8	B
	Through	359	357	99.5%	0.1	6.3	1.3	A
	Right Turn	91	90	99.3%	0.1	1.2	0.6	A
	Subtotal	496	494	99.5%	0.1	5.8	1.0	A
Total		1806	1808	100.1%	0.0	20.1	0.8	C

Intersection Fair Oaks Lane/Middlefield Road

Unsignalized

Direction	Movement	Volume (veh/hr)			GEH	Total Delay (sec/veh)		
		Demand	Served	% Served		Average	Std. Dev.	LOS
NB	Left Turn	28	27	95.7%	0.2	58.8	19.9	F
	Through	13	12	90.0%	0.4	45.3	23.4	E
	Right Turn	122	118	96.8%	0.4	18.1	8.6	C
	Subtotal	163	157	96.1%	0.5	27.2	11.5	D
SB	Left Turn	7	7	101.4%	0.0	41.5	13.6	E
	Through	14	13	90.0%	0.4	35.7	18.3	E
	Right Turn							
	Subtotal	21	20	93.8%	0.3	41.3	14.6	E
EB	Left Turn	10	8	84.0%	0.5	6.1	1.6	A
	Through	538	538	99.9%	0.0	2.9	0.4	A
	Right Turn	34	35	102.1%	0.1	2.2	0.6	A
	Subtotal	582	581	99.8%	0.1	2.9	0.4	A
WB	Left Turn	185	180	97.4%	0.4	11.0	1.2	B
	Through	720	714	99.1%	0.2	5.1	0.3	A
	Right Turn	18	17	93.9%	0.3	3.7	0.9	A
	Subtotal	923	911	98.6%	0.4	6.3	0.4	A
Total		1689	1668	98.7%	0.5	7.4	1.3	A

Intersection Watkins Avenue/Middlefield Road

Unsignalized

Direction	Movement	Volume (veh/hr)			GEH	Total Delay (sec/veh)		
		Demand	Served	% Served		Average	Std. Dev.	LOS
NB	Left Turn	42	44	105.2%	0.3	44.1	11.4	E
	Through							
	Right Turn	50	50	100.4%	0.0	13.8	3.0	B
	Subtotal	92	94	102.6%	0.2	28.3	7.8	D
SB	Left Turn							
	Through							
	Right Turn							
	Subtotal							
EB	Left Turn							
	Through	593	592	99.9%	0.0	3.7	0.3	A
	Right Turn	74	73	98.2%	0.2	3.0	0.3	A
	Subtotal	667	665	99.7%	0.1	3.6	0.2	A
WB	Left Turn	77	77	100.5%	0.0	12.8	1.1	B
	Through	881	879	99.7%	0.1	6.5	0.3	A
	Right Turn							
	Subtotal	958	956	99.8%	0.1	7.0	0.3	A
Total		1717	1715	99.9%	0.0	6.8	0.4	A

SimTraffic Post-Processor
Average Results from 20 Runs
Volume and Delay by Movement

Caltrain Electrification
Existing Conditions
PM Peak Hour

Intersection

Linden Avenue-Glenwood Avenue/Middlefield Road

Unsignalized

Direction	Movement	Volume (veh/hr)			GEH	Total Delay (sec/veh)		
		Demand	Served	% Served		Average	Std. Dev.	LOS
NB	Left Turn	120	94	78.2%	2.5	630.8	145.0	F
	Through	19	14	73.7%	1.2	656.0	156.9	F
	Right Turn	105	92	87.9%	1.3	547.6	145.4	F
	Subtotal	244	200	82.0%	2.9	594.7	142.1	F
SB	Left Turn	17	16	93.5%	0.3	83.1	51.2	F
	Through	3	3	110.0%	0.2	52.6	33.9	F
	Right Turn	50	49	97.0%	0.2	46.1	25.9	E
	Subtotal	70	68	96.7%	0.3	55.8	31.8	F
EB	Left Turn	46	44	96.5%	0.2	18.5	3.1	C
	Through	471	480	101.9%	0.4	7.4	0.3	A
	Right Turn	126	129	102.1%	0.2	6.1	0.3	A
	Subtotal	643	653	101.5%	0.4	7.9	0.3	A
WB	Left Turn	113	113	100.0%	0.0	14.0	0.9	B
	Through	788	795	100.9%	0.3	6.0	0.5	A
	Right Turn	89	93	104.0%	0.4	4.9	0.7	A
	Subtotal	990	1001	101.1%	0.3	6.8	0.5	A
Total		1947	1922	98.7%	0.6	69.8	15.3	F

SimTraffic Post-Processor
Average Results from 20 Runs
Volume and Delay by Movement

Caltrain Electrification
Existing Conditions
PM Peak Hour

Intersection California Street/Rengstorff Avenue

Signalized

Direction	Movement	Volume (veh/hr)			GEH	Total Delay (sec/veh)		
		Demand	Served	% Served		Average	Std. Dev.	LOS
NB	Left Turn	51	49	96.7%	0.2	95.4	6.0	F
	Through	347	347	100.0%	0.0	41.8	2.7	D
	Right Turn	85	88	103.6%	0.3	39.5	5.7	D
	Subtotal	483	484	100.3%	0.1	46.9	2.4	D
SB	Left Turn	144	143	99.2%	0.1	108.3	9.2	F
	Through	485	483	99.5%	0.1	36.4	2.7	D
	Right Turn	54	52	96.9%	0.2	32.7	4.8	C
	Subtotal	683	678	99.3%	0.2	51.2	4.0	D
EB	Left Turn	53	50	93.6%	0.5	104.4	6.7	F
	Through	293	301	102.8%	0.5	53.5	3.1	D
	Right Turn	39	41	104.9%	0.3	43.8	6.1	D
	Subtotal	385	392	101.8%	0.3	58.9	3.1	E
WB	Left Turn	178	170	95.7%	0.6	118.0	9.5	F
	Through	393	399	101.6%	0.3	48.1	3.1	D
	Right Turn	180	177	98.3%	0.2	46.3	5.2	D
	Subtotal	751	747	99.4%	0.2	63.6	4.1	E
Total		2302	2301	99.9%	0.0	55.6	1.3	E

2020 No Project



Intersection Pennsylvania Street/22nd Street

Unsignalized

Direction	Movement	Volume (veh/hr)			GEH	Total Delay (sec/veh)		
		Demand	Served	% Served		Average	Std. Dev.	LOS
NB	Left Turn	60	57	94.2%	0.5	8.8	1.1	A
	Through	170	161	94.5%	0.7	9.8	0.7	A
	Right Turn	60	58	96.2%	0.3	8.0	0.9	A
	Subtotal	290	275	94.8%	0.9	9.2	0.6	A
SB	Left Turn	30	27	90.0%	0.6	6.7	1.0	A
	Through	80	72	90.3%	0.9	7.7	0.6	A
	Right Turn	20	19	97.0%	0.1	4.9	1.0	A
	Subtotal	130	119	91.2%	1.0	7.0	0.5	A
EB	Left Turn	10	7	71.0%	1.0	5.3	0.9	A
	Through	20	21	106.5%	0.3	7.1	0.8	A
	Right Turn	70	73	104.3%	0.4	4.6	0.5	A
	Subtotal	100	101	101.4%	0.1	5.2	0.5	A
WB	Left Turn	70	67	96.0%	0.3	6.7	0.5	A
	Through	30	31	104.0%	0.2	6.5	0.8	A
	Right Turn	20	22	108.0%	0.4	4.9	0.7	A
	Subtotal	120	120	100.0%	0.0	6.3	0.3	A
Total		640	615	96.1%	1.0	7.5	0.3	A

Intersection Indiana Street/22nd Street

Unsignalized

Direction	Movement	Volume (veh/hr)			GEH	Total Delay (sec/veh)		
		Demand	Served	% Served		Average	Std. Dev.	LOS
NB	Left Turn	10	10	96.0%	0.1	6.6	1.7	A
	Through	70	69	99.1%	0.1	6.9	0.5	A
	Right Turn	50	54	108.4%	0.6	5.0	0.4	A
	Subtotal	130	133	102.5%	0.3	6.1	0.4	A
SB	Left Turn	10	9	86.0%	0.5	5.6	1.1	A
	Through	20	19	94.0%	0.3	6.6	0.5	A
	Right Turn	10	11	105.0%	0.2	3.7	0.6	A
	Subtotal	40	38	94.8%	0.3	5.6	0.4	A
EB	Left Turn	20	20	99.0%	0.0	5.7	1.2	A
	Through	90	88	97.4%	0.2	5.6	0.2	A
	Right Turn	20	21	102.5%	0.1	3.9	0.4	A
	Subtotal	130	128	98.5%	0.2	5.3	0.3	A
WB	Left Turn	10	7	74.0%	0.9	4.9	0.8	A
	Through	70	66	93.9%	0.5	5.5	0.3	A
	Right Turn	10	10	103.0%	0.1	4.1	0.7	A
	Subtotal	90	83	92.7%	0.7	5.3	0.3	A
Total		390	383	98.1%	0.4	5.6	0.3	A

SimTraffic Post-Processor
Average Results from 20 Runs
Volume and Delay by Movement

Caltrain Electrification
2020 No Project Conditions
AM Peak Hour

Intersection

Tunnel Avenue/Blanken Avenue

Unsignalized

Direction	Movement	Volume (veh/hr)			GEH	Total Delay (sec/veh)		
		Demand	Served	% Served		Average	Std. Dev.	LOS
NB	Left Turn	50	52	104.2%	0.3	10.7	1.0	B
	Through	130	132	101.2%	0.1	11.7	1.0	B
	Right Turn	20	20	101.0%	0.0	8.8	2.1	A
	Subtotal	200	204	102.0%	0.3	11.2	0.9	B
SB	Left Turn	60	59	97.7%	0.2	8.8	1.0	A
	Through	110	109	98.6%	0.1	10.5	1.2	B
	Right Turn	10	12	122.0%	0.7	6.8	1.6	A
	Subtotal	180	179	99.6%	0.1	9.7	0.9	A
EB	Left Turn	20	19	93.5%	0.3	15.5	3.0	C
	Through	190	189	99.5%	0.1	16.5	2.2	C
	Right Turn	190	191	100.4%	0.1	14.1	2.2	B
	Subtotal	400	399	99.6%	0.1	15.3	2.0	C
WB	Left Turn	20	20	101.0%	0.0	9.5	1.8	A
	Through	80	80	99.9%	0.0	9.9	0.8	A
	Right Turn	70	67	95.3%	0.4	6.4	1.3	A
	Subtotal	170	167	98.1%	0.2	8.5	1.0	A
Total		950	949	99.8%	0.0	12.1	1.0	B

SimTraffic Post-Processor
Average Results from 20 Runs
Volume and Delay by Movement

Caltrain Electrification
2020 No Project Conditions
AM Peak Hour

Intersection

Dubuque Avenue/Grand Avenue

Signalized

Direction	Movement	Volume (veh/hr)			GEH	Total Delay (sec/veh)		
		Demand	Served	% Served		Average	Std. Dev.	LOS
NB	Left Turn							
	Through							
	Right Turn							
	Subtotal							
SB	Left Turn	30	31	103.7%	0.2	33.2	3.1	C
	Through							
	Right Turn	60	64	106.3%	0.5	9.4	0.7	A
	Subtotal	90	95	105.4%	0.5	17.3	2.1	B
EB	Left Turn	40	43	106.8%	0.4	43.9	6.9	D
	Through	650	628	96.6%	0.9	5.8	0.7	A
	Right Turn							
	Subtotal	690	670	97.1%	0.8	8.2	0.8	A
WB	Left Turn							
	Through	520	514	98.8%	0.3	8.5	0.7	A
	Right Turn	40	41	103.0%	0.2	6.5	1.6	A
	Subtotal	560	555	99.1%	0.2	8.3	0.7	A
Total		1340	1320	98.5%	0.5	8.9	0.6	A

Intersection

Linden Avenue-San Mateo Avenue/San Mateo Avenue

Signalized

Direction	Movement	Volume (veh/hr)			GEH	Total Delay (sec/veh)		
		Demand	Served	% Served		Average	Std. Dev.	LOS
NB	Left Turn							
	Through	90	93	102.8%	0.3	5.4	0.9	A
	Right Turn	200	208	103.8%	0.5	1.2	0.1	A
	Subtotal	290	300	103.5%	0.6	2.5	0.2	A
SB	Left Turn	140	140	99.9%	0.0	20.2	2.0	C
	Through	140	135	96.5%	0.4	3.1	0.5	A
	Right Turn							
	Subtotal	280	275	98.2%	0.3	11.8	1.2	B
EB	Left Turn							
	Through							
	Right Turn							
	Subtotal							
WB	Left Turn	190	188	98.7%	0.2	12.2	0.4	B
	Through							
	Right Turn	110	115	104.9%	0.5	6.2	0.2	A
	Subtotal	300	303	101.0%	0.2	9.9	0.3	A
Total		870	878	100.9%	0.3	8.0	0.4	A

Intersection

Herman Street/Scott Street

Unsignalized

Direction	Movement	Volume (veh/hr)			GEH	Total Delay (sec/veh)		
		Demand	Served	% Served		Average	Std. Dev.	LOS
NB	Left Turn	10	9	92.0%	0.3	10.8	2.0	B
	Through	130	128	98.1%	0.2	12.8	1.6	B
	Right Turn	150	154	102.3%	0.3	10.1	2.4	B
	Subtotal	290	290	100.1%	0.0	11.3	1.9	B
SB	Left Turn	40	34	85.8%	0.9	10.3	1.6	B
	Through	110	110	100.4%	0.0	9.6	1.1	A
	Right Turn	10	10	103.0%	0.1	6.8	2.0	A
	Subtotal	160	155	96.9%	0.4	9.6	1.3	A
EB	Left Turn	10	10	97.0%	0.1	6.3	2.2	A
	Through	30	30	100.3%	0.0	8.7	0.8	A
	Right Turn	10	11	112.0%	0.4	5.0	3.4	A
	Subtotal	50	51	102.0%	0.1	7.5	1.4	A
WB	Left Turn	60	62	103.3%	0.3	0.3	0.1	A
	Through	10	12	119.0%	0.6	0.7	0.4	A
	Right Turn	60	62	102.7%	0.2	0.2	0.1	A
	Subtotal	130	136	104.2%	0.5	0.3	0.1	A
Total		630	632	100.3%	0.1	8.2	1.1	A

Intersection **Montgomery Avenue/Scott Street**

Unsignalized

Direction	Movement	Volume (veh/hr)			GEH	Total Delay (sec/veh)		
		Demand	Served	% Served		Average	Std. Dev.	LOS
NB	Left Turn	20	19	96.0%	0.2	6.4	1.2	A
	Through	10	11	106.0%	0.2	7.2	1.1	A
	Right Turn	10	10	100.0%	0.0	3.8	1.2	A
	Subtotal	40	40	99.5%	0.0	5.9	0.8	A
SB	Left Turn	20	20	101.0%	0.0	5.4	0.5	A
	Through	10	11	106.0%	0.2	7.1	1.1	A
	Right Turn	10	10	96.0%	0.1	3.1	0.5	A
	Subtotal	40	40	101.0%	0.1	5.3	0.4	A
EB	Left Turn	40	37	93.3%	0.4	2.2	0.3	A
	Through	150	152	101.4%	0.2	0.7	0.2	A
	Right Turn	30	29	97.7%	0.1	0.3	0.1	A
	Subtotal	220	219	99.4%	0.1	0.9	0.2	A
WB	Left Turn	10	9	88.0%	0.4	2.1	0.7	A
	Through	100	105	104.9%	0.5	0.3	0.1	A
	Right Turn	10	10	95.0%	0.2	0.3	0.3	A
	Subtotal	120	123	102.7%	0.3	0.4	0.1	A
Total		420	422	100.5%	0.1	1.7	0.1	A

Intersection **Driveway-Dollar Avenue/Linden Avenue**

Signalized

Direction	Movement	Volume (veh/hr)			GEH	Total Delay (sec/veh)		
		Demand	Served	% Served		Average	Std. Dev.	LOS
NB	Left Turn	70	75	106.4%	0.5	23.2	2.1	C
	Through							
	Right Turn	70	68	97.0%	0.3	15.2	2.5	B
	Subtotal	140	142	101.7%	0.2	19.4	2.0	B
SB	Left Turn	10	10	103.0%	0.1	35.4	9.8	D
	Through							
	Right Turn							
	Subtotal	10	10	103.0%	0.1	35.4	9.8	D
EB	Left Turn							
	Through	200	195	97.5%	0.4	26.3	4.4	C
	Right Turn	80	76	95.3%	0.4	16.9	3.3	B
	Subtotal	280	271	96.8%	0.5	23.7	4.0	C
WB	Left Turn	50	50	99.8%	0.0	2.3	0.9	A
	Through	140	147	105.2%	0.6	2.6	0.8	A
	Right Turn	10	11	109.0%	0.3	0.3	0.1	A
	Subtotal	200	208	104.1%	0.6	2.4	0.6	A
Total		630	632	100.3%	0.1	15.9	2.3	B

SimTraffic Post-Processor
Average Results from 20 Runs
Volume and Delay by Movement

Caltrain Electrification
2020 No Project Conditions
AM Peak Hour

Intersection

San Mateo Avenue/San Bruno Avenue

Signalized

Direction	Movement	Volume (veh/hr)			GEH	Total Delay (sec/veh)		
		Demand	Served	% Served		Average	Std. Dev.	LOS
NB	Left Turn	10	10	104.0%	0.1	32.6	8.3	C
	Through	90	87	97.0%	0.3	26.2	3.6	C
	Right Turn	220	221	100.2%	0.0	10.0	0.5	A
	Subtotal	320	318	99.4%	0.1	15.1	1.4	B
SB	Left Turn	90	87	97.0%	0.3	37.3	2.8	D
	Through	60	61	101.2%	0.1	27.0	3.4	C
	Right Turn	40	39	98.5%	0.1	9.4	2.1	A
	Subtotal	190	187	98.6%	0.2	28.1	1.9	C
EB	Left Turn	50	49	98.0%	0.1	18.5	4.9	B
	Through	370	371	100.2%	0.0	8.5	1.4	A
	Right Turn	10	10	103.0%	0.1	3.6	2.3	A
	Subtotal	430	430	100.0%	0.0	9.5	1.5	A
WB	Left Turn	230	228	99.0%	0.2	41.5	2.6	D
	Through	360	348	96.5%	0.7	20.4	1.1	C
	Right Turn	130	131	100.8%	0.1	15.0	1.4	B
	Subtotal	720	706	98.1%	0.5	26.2	0.8	C
Total		1660	1642	98.9%	0.4	19.9	0.7	B

Intersection

El Camino Real/Millbrae Avenue

Signalized

Direction	Movement	Volume (veh/hr)			GEH	Total Delay (sec/veh)		
		Demand	Served	% Served		Average	Std. Dev.	LOS
NB	Left Turn	50	48	96.4%	0.3	78.4	6.8	E
	Through	420	415	98.9%	0.2	38.0	2.3	D
	Right Turn	550	570	103.6%	0.8	5.8	0.6	A
	Subtotal	1020	1033	101.3%	0.4	22.2	1.0	C
SB	Left Turn	670	628	93.7%	1.7	212.3	39.6	F
	Through	790	761	96.3%	1.0	69.5	24.0	E
	Right Turn	40	41	103.0%	0.2	69.2	29.9	E
	Subtotal	1500	1430	95.3%	1.8	132.1	30.1	F
EB	Left Turn	60	62	102.8%	0.2	104.6	15.7	F
	Through	720	730	101.4%	0.4	62.7	8.4	E
	Right Turn	30	29	96.0%	0.2	63.0	12.7	E
	Subtotal	810	820	101.3%	0.4	65.8	9.0	E
WB	Left Turn	460	455	99.0%	0.2	130.5	38.3	F
	Through	210	221	105.2%	0.7	35.3	2.9	D
	Right Turn	530	528	99.6%	0.1	11.5	1.1	B
	Subtotal	1200	1204	100.4%	0.1	61.2	15.6	E
Total		4530	4487	99.1%	0.6	75.7	10.6	E

Intersection

Rollins Road/Millbrae Avenue

Signalized

Direction	Movement	Volume (veh/hr)			GEH	Total Delay (sec/veh)		
		Demand	Served	% Served		Average	Std. Dev.	LOS
NB	Left Turn	120	120	100.3%	0.0	39.6	3.7	D
	Through	120	124	102.9%	0.3	99.6	18.9	F
	Right Turn	250	255	102.1%	0.3	27.6	9.0	C
	Subtotal	490	499	101.9%	0.4	48.4	8.2	D
SB	Left Turn	200	199	99.7%	0.0	26.7	1.0	C
	Through	20	19	92.5%	0.3	23.9	4.9	C
	Right Turn	70	68	96.4%	0.3	7.0	0.9	A
	Subtotal	290	285	98.4%	0.3	21.8	0.8	C
EB	Left Turn	350	345	98.5%	0.3	70.2	21.2	E
	Through	1300	1305	100.4%	0.1	32.2	1.9	C
	Right Turn	290	284	97.9%	0.4	18.8	1.8	B
	Subtotal	1940	1933	99.6%	0.2	37.1	4.6	D
WB	Left Turn	440	438	99.5%	0.1	56.2	10.0	E
	Through	1010	1019	100.9%	0.3	42.8	6.6	D
	Right Turn	470	481	102.4%	0.5	13.4	1.2	B
	Subtotal	1920	1938	100.9%	0.4	38.5	5.8	D
Total		4640	4656	100.3%	0.2	38.0	4.1	D

Intersection **California Drive/Oak Grove Avenue**

Signalized

Direction	Movement	Volume (veh/hr)			GEH	Total Delay (sec/veh)		
		Demand	Served	% Served		Average	Std. Dev.	LOS
NB	Left Turn	30	28	92.7%	0.4	57.1	6.4	E
	Through	480	469	97.7%	0.5	30.8	1.6	C
	Right Turn	230	231	100.3%	0.1	10.3	1.5	B
	Subtotal	740	728	98.3%	0.5	25.3	1.5	C
SB	Left Turn	120	95	79.1%	2.4	596.0	172.5	F
	Through	630	577	91.6%	2.1	135.3	69.2	F
	Right Turn	50	45	89.6%	0.8	100.5	58.9	F
	Subtotal	800	717	89.6%	3.0	194.3	81.2	F
EB	Left Turn	90	86	95.9%	0.4	75.8	24.7	E
	Through	310	303	97.6%	0.4	84.2	28.6	F
	Right Turn	30	30	100.7%	0.0	79.6	42.7	E
	Subtotal	430	419	97.5%	0.5	82.2	28.8	F
WB	Left Turn	160	146	91.3%	1.1	28.4	1.8	C
	Through	100	93	93.4%	0.7	30.0	2.8	C
	Right Turn	90	82	91.1%	0.9	14.9	1.9	B
	Subtotal	350	321	91.8%	1.6	25.4	1.8	C
Total		2320	2185	94.2%	2.8	91.3	25.5	F

Intersection **Carolan Avenue/Oak Grove Avenue**

Unsignalized

Direction	Movement	Volume (veh/hr)			GEH	Total Delay (sec/veh)		
		Demand	Served	% Served		Average	Std. Dev.	LOS
NB	Left Turn	50	40	80.2%	1.5	326.6	143.9	F
	Through	100	93	92.6%	0.8	305.2	135.7	F
	Right Turn	40	34	85.0%	1.0	295.5	135.1	F
	Subtotal	190	167	87.7%	1.7	308.7	136.8	F
SB	Left Turn	10	9	86.0%	0.5	74.0	29.4	F
	Through	140	134	95.8%	0.5	79.2	31.3	F
	Right Turn	170	163	95.6%	0.6	153.5	87.5	F
	Subtotal	320	305	95.4%	0.8	119.3	58.6	F
EB	Left Turn	390	372	95.5%	0.9	0.4	0.1	A
	Through	140	140	100.0%	0.0	1.2	0.1	A
	Right Turn	130	123	94.2%	0.7	0.2	0.0	A
	Subtotal	660	635	96.2%	1.0	0.6	0.1	A
WB	Left Turn	20	16	81.0%	0.9	328.6	81.6	F
	Through	130	114	87.7%	1.4	346.4	101.3	F
	Right Turn	20	16	79.0%	1.0	314.4	106.0	F
	Subtotal	170	146	85.9%	1.9	341.2	96.5	F
Total		1340	1253	93.5%	2.4	109.9	28.6	F

Intersection California Drive/North Lane

Unsignalized

Direction	Movement	Volume (veh/hr)			GEH	Total Delay (sec/veh)		
		Demand	Served	% Served		Average	Std. Dev.	LOS
NB	Left Turn							
	Through	730	720	98.6%	0.4	1.2	0.2	A
	Right Turn	190	181	95.4%	0.6	2.5	0.7	A
	Subtotal	920	901	97.9%	0.6	1.4	0.2	A
SB	Left Turn	130	115	88.5%	1.4	38.8	25.6	E
	Through	660	613	92.9%	1.9	3.1	1.1	A
	Right Turn							
	Subtotal	790	728	92.2%	2.2	8.8	5.3	A
EB	Left Turn							
	Through							
	Right Turn							
	Subtotal							
WB	Left Turn	60	60	99.3%	0.1	37.1	6.3	E
	Through							
	Right Turn	110	111	100.5%	0.1	5.0	0.6	A
	Subtotal	170	170	100.1%	0.0	16.3	2.9	C
Total		1880	1799	95.7%	1.9	5.8	2.3	A

Intersection Carolan Avenue/North Lane

Unsignalized

Direction	Movement	Volume (veh/hr)			GEH	Total Delay (sec/veh)		
		Demand	Served	% Served		Average	Std. Dev.	LOS
NB	Left Turn	80	81	101.3%	0.1	52.5	29.5	F
	Through	150	144	95.9%	0.5	23.9	15.2	C
	Right Turn	20	18	89.0%	0.5	16.6	14.3	C
	Subtotal	250	243	97.0%	0.5	32.9	19.7	D
SB	Left Turn	10	9	93.0%	0.2	16.2	6.2	C
	Through	130	120	91.9%	0.9	20.2	5.2	C
	Right Turn	90	86	95.3%	0.4	19.8	6.4	C
	Subtotal	230	215	93.3%	1.0	19.8	4.3	C
EB	Left Turn	210	197	93.6%	0.9	1.2	1.0	A
	Through	20	22	109.5%	0.4	0.9	0.3	A
	Right Turn	90	84	92.9%	0.7	0.4	0.2	A
	Subtotal	320	302	94.4%	1.0	0.9	0.7	A
WB	Left Turn							
	Through							
	Right Turn							
	Subtotal							
Total		800	759	94.9%	1.5	16.5	7.4	C

Intersection Anita Road/Peninsula Avenue

Unsignalized

Direction	Movement	Volume (veh/hr)			GEH	Total Delay (sec/veh)		
		Demand	Served	% Served		Average	Std. Dev.	LOS
NB	Left Turn							
	Through							
	Right Turn							
	Subtotal							
SB	Left Turn	30	25	84.7%	0.9	17.8	6.1	C
	Through							
	Right Turn	30	30	101.3%	0.1	16.5	11.9	C
	Subtotal	60	56	93.0%	0.6	17.2	9.0	C
EB	Left Turn	50	51	102.4%	0.2	8.8	1.8	A
	Through	560	566	101.1%	0.2	0.8	0.2	A
	Right Turn							
	Subtotal	610	617	101.2%	0.3	1.5	0.4	A
WB	Left Turn							
	Through	530	557	105.1%	1.2	5.9	1.5	A
	Right Turn	70	68	97.4%	0.2	4.4	2.0	A
	Subtotal	600	625	104.2%	1.0	5.7	1.5	A
Total		1270	1298	102.2%	0.8	4.2	1.1	A

Intersection Woodside Way/Villa Terrace

Unsignalized

Direction	Movement	Volume (veh/hr)			GEH	Total Delay (sec/veh)		
		Demand	Served	% Served		Average	Std. Dev.	LOS
NB	Left Turn	10	10	95.0%	0.2	5.0	1.0	A
	Through	30	29	97.0%	0.2	6.0	0.4	A
	Right Turn	10	12	116.0%	0.5	3.2	1.8	A
	Subtotal	50	50	100.4%	0.0	5.1	0.7	A
SB	Left Turn	10	10	104.0%	0.1	5.6	0.8	A
	Through	20	24	119.5%	0.8	6.0	0.8	A
	Right Turn	60	55	92.3%	0.6	3.4	0.4	A
	Subtotal	90	90	99.7%	0.0	4.3	0.3	A
EB	Left Turn	50	48	96.6%	0.2	2.1	0.2	A
	Through	30	31	103.3%	0.2	0.7	0.3	A
	Right Turn	10	9	86.0%	0.5	0.4	0.4	A
	Subtotal	90	88	97.7%	0.2	1.4	0.2	A
WB	Left Turn	10	8	80.0%	0.7	1.9	0.3	A
	Through	20	21	104.0%	0.2	0.4	0.2	A
	Right Turn	20	23	112.5%	0.5	0.2	0.1	A
	Subtotal	50	51	102.6%	0.2	0.5	0.2	A
Total		280	279	99.7%	0.1	2.9	0.2	A

Intersection N. San Mateo Drive/Villa Terrace

Unsignalized

Direction	Movement	Volume (veh/hr)			GEH	Total Delay (sec/veh)		
		Demand	Served	% Served		Average	Std. Dev.	LOS
NB	Left Turn	20	19	93.5%	0.3	4.6	1.2	A
	Through	440	441	100.2%	0.0	0.6	0.1	A
	Right Turn	40	37	93.5%	0.4	0.7	0.2	A
	Subtotal	500	497	99.4%	0.1	0.7	0.1	A
SB	Left Turn	20	18	89.5%	0.5	5.1	0.8	A
	Through	520	519	99.8%	0.0	2.3	0.1	A
	Right Turn	20	21	106.0%	0.3	2.2	0.7	A
	Subtotal	560	558	99.7%	0.1	2.3	0.2	A
EB	Left Turn	10	9	86.0%	0.5	16.0	5.9	C
	Through	30	32	105.7%	0.3	14.5	2.3	B
	Right Turn	20	17	86.0%	0.6	5.8	2.1	A
	Subtotal	60	58	95.8%	0.3	12.0	1.9	B
WB	Left Turn	40	37	92.3%	0.5	11.4	1.7	B
	Through	30	28	93.0%	0.4	14.1	2.2	B
	Right Turn	20	22	111.0%	0.5	7.4	3.5	A
	Subtotal	90	87	96.7%	0.3	11.2	1.9	B
Total		1210	1200	99.1%	0.3	2.8	0.1	A

Intersection Arundel Road/Peninsula Avenue

Unsignalized

Direction	Movement	Volume (veh/hr)			GEH	Total Delay (sec/veh)		
		Demand	Served	% Served		Average	Std. Dev.	LOS
NB	Left Turn	30	29	97.7%	0.1	29.4	9.5	D
	Through	10	12	119.0%	0.6	21.1	8.1	C
	Right Turn	60	62	103.0%	0.2	13.1	3.3	B
	Subtotal	100	103	103.0%	0.3	18.8	5.3	C
SB	Left Turn	20	20	98.5%	0.1	15.2	4.0	C
	Through	10	11	112.0%	0.4	18.7	3.3	C
	Right Turn	10	9	87.0%	0.4	7.4	3.3	A
	Subtotal	40	40	99.0%	0.1	14.2	2.9	B
EB	Left Turn	10	9	93.0%	0.2	5.0	2.2	A
	Through	540	547	101.3%	0.3	0.6	0.0	A
	Right Turn	40	37	91.5%	0.5	0.6	0.2	A
	Subtotal	590	593	100.5%	0.1	0.6	0.1	A
WB	Left Turn	40	40	98.8%	0.1	6.7	1.3	A
	Through	560	568	101.5%	0.4	3.5	0.8	A
	Right Turn	30	29	97.3%	0.1	2.7	1.2	A
	Subtotal	630	637	101.1%	0.3	3.6	0.8	A
Total		1360	1372	100.9%	0.3	3.8	0.6	A

Intersection **Railroad Ave/1st Ave**

Unsignalized

Direction	Movement	Volume (veh/hr)			GEH	Total Delay (sec/veh)		
		Demand	Served	% Served		Average	Std. Dev.	LOS
NB	Left Turn	10	9	91.0%	0.3	18.9	10.3	C
	Through	10	11	105.0%	0.2	12.9	7.5	B
	Right Turn	10	10	99.0%	0.0	6.8	3.1	A
	Subtotal	30	30	98.3%	0.1	12.6	4.3	B
SB	Left Turn							
	Through							
	Right Turn							
	Subtotal							
EB	Left Turn	20	20	98.5%	0.1	1.8	0.7	A
	Through	50	49	98.4%	0.1	0.4	0.2	A
	Right Turn							
	Subtotal	70	69	98.4%	0.1	0.8	0.3	A
WB	Left Turn							
	Through	130	130	99.7%	0.0	8.4	1.7	A
	Right Turn	10	12	120.0%	0.6	3.1	2.0	A
	Subtotal	140	142	101.1%	0.1	8.0	1.7	A
Total		240	240	100.0%	0.0	6.5	1.5	A

Intersection **S. B. St/1st Ave**

Signalized

Direction	Movement	Volume (veh/hr)			GEH	Total Delay (sec/veh)		
		Demand	Served	% Served		Average	Std. Dev.	LOS
NB	Left Turn	20	20	98.5%	0.1	23.7	8.9	C
	Through	150	154	102.9%	0.3	12.4	3.9	B
	Right Turn	20	21	102.5%	0.1	7.6	2.9	A
	Subtotal	190	195	102.4%	0.3	13.0	3.7	B
SB	Left Turn	30	26	87.3%	0.7	14.9	4.1	B
	Through	180	186	103.3%	0.4	9.1	2.7	A
	Right Turn	10	12	117.0%	0.5	6.8	8.0	A
	Subtotal	220	224	101.8%	0.3	9.6	2.9	A
EB	Left Turn	10	11	112.0%	0.4	62.1	14.8	E
	Through	40	37	92.3%	0.5	55.4	10.0	E
	Right Turn	20	19	93.0%	0.3	20.4	5.8	C
	Subtotal	70	67	95.3%	0.4	46.7	5.3	D
WB	Left Turn	20	18	91.0%	0.4	58.0	7.1	E
	Through	50	52	103.4%	0.2	49.8	8.0	D
	Right Turn	60	61	101.0%	0.1	29.6	7.2	C
	Subtotal	130	131	100.4%	0.0	41.7	7.3	D
Total		610	616	100.9%	0.2	21.6	2.5	C

SimTraffic Post-Processor
Average Results from 20 Runs
Volume and Delay by Movement

Caltrain Electrification
2020 No Project Conditions
AM Peak Hour

Intersection

Transit Center Way/1st St

Unsignalized

Direction	Movement	Volume (veh/hr)			GEH	Total Delay (sec/veh)		
		Demand	Served	% Served		Average	Std. Dev.	LOS
NB	Left Turn	10	9	89.0%	0.4	7.6	9.3	A
	Through	10	10	95.0%	0.2	4.2	4.7	A
	Right Turn	10	11	110.0%	0.3	5.0	3.2	A
	Subtotal	30	29	98.0%	0.1	5.3	4.4	A
SB	Left Turn							
	Through							
	Right Turn							
	Subtotal							
EB	Left Turn	20	19	95.0%	0.2	3.3	1.0	A
	Through	60	58	97.3%	0.2	2.1	0.8	A
	Right Turn	10	8	78.0%	0.7	1.1	1.4	A
	Subtotal	90	85	94.7%	0.5	2.3	0.6	A
WB	Left Turn							
	Through	120	119	99.0%	0.1	2.6	2.1	A
	Right Turn	20	21	105.0%	0.2	1.1	1.6	A
	Subtotal	140	140	99.9%	0.0	2.4	1.8	A
Total		260	254	97.8%	0.3	2.7	1.5	A

SimTraffic Post-Processor
Average Results from 20 Runs
Volume and Delay by Movement

Caltrain Electrification
2020 No Project Conditions
AM Peak Hour

Intersection **Railroad Avenue/9th Avenue**

Unsignalized

Direction	Movement	Volume (veh/hr)			GEH	Total Delay (sec/veh)		
		Demand	Served	% Served		Average	Std. Dev.	LOS
NB	Left Turn	58	58	99.8%	0.0	46.0	12.0	E
	Through							
	Right Turn	20	23	113.0%	0.6	31.6	14.5	D
	Subtotal	78	81	103.2%	0.3	41.8	11.8	E
SB	Left Turn							
	Through							
	Right Turn							
	Subtotal							
EB	Left Turn							
	Through	440	430	97.6%	0.5	0.9	0.2	A
	Right Turn	90	88	97.8%	0.2	0.2	0.1	A
	Subtotal	530	518	97.6%	0.5	0.8	0.2	A
WB	Left Turn	6	6	93.3%	0.2	9.0	5.5	A
	Through	442	448	101.4%	0.3	5.4	1.6	A
	Right Turn							
	Subtotal	448	454	101.3%	0.3	5.5	1.6	A
Total		1056	1052	99.6%	0.1	6.0	1.7	A

Intersection **S B Street/9th Avenue**

Signalized

Direction	Movement	Volume (veh/hr)			GEH	Total Delay (sec/veh)		
		Demand	Served	% Served		Average	Std. Dev.	LOS
NB	Left Turn	10	12	115.0%	0.5	22.4	2.6	C
	Through	110	110	100.3%	0.0	17.5	1.6	B
	Right Turn	160	156	97.8%	0.3	11.5	1.6	B
	Subtotal	280	278	99.4%	0.1	14.3	1.5	B
SB	Left Turn	80	75	93.9%	0.6	30.6	7.5	C
	Through	50	54	107.2%	0.5	12.7	3.0	B
	Right Turn	40	42	104.5%	0.3	5.7	1.7	A
	Subtotal	170	171	100.3%	0.0	18.8	4.2	B
EB	Left Turn	40	37	93.5%	0.4	27.9	4.1	C
	Through	290	285	98.2%	0.3	21.9	3.7	C
	Right Turn	10	9	90.0%	0.3	14.8	5.9	B
	Subtotal	340	331	97.4%	0.5	22.4	3.5	C
WB	Left Turn	100	100	100.0%	0.0	15.2	1.9	B
	Through	300	306	102.0%	0.4	9.1	0.8	A
	Right Turn	90	85	94.1%	0.6	5.5	1.0	A
	Subtotal	490	491	100.2%	0.0	9.8	0.9	A
Total		1280	1271	99.3%	0.3	15.3	1.3	B

Intersection

Concar Drive/SR 92 WB Ramps

Signalized

Direction	Movement	Volume (veh/hr)			GEH	Total Delay (sec/veh)		
		Demand	Served	% Served		Average	Std. Dev.	LOS
NB	Left Turn	50	49	97.8%	0.2	23.9	1.5	C
	Through	50	50	100.6%	0.0	23.2	1.8	C
	Right Turn							
	Subtotal	100	99	99.2%	0.1	23.5	1.5	C
SB	Left Turn	10	10	98.0%	0.1	17.1	3.6	B
	Through	10	10	104.0%	0.1	16.2	4.0	B
	Right Turn	10	11	106.0%	0.2	3.9	2.4	A
	Subtotal	30	31	102.7%	0.1	12.3	2.6	B
EB	Left Turn	10	10	97.0%	0.1	21.8	5.0	C
	Through	60	60	100.5%	0.0	24.2	2.9	C
	Right Turn	30	33	108.3%	0.4	12.1	1.5	B
	Subtotal	100	103	102.5%	0.2	20.1	1.8	C
WB	Left Turn	760	751	98.8%	0.3	3.0	0.3	A
	Through	30	33	110.7%	0.6	4.4	0.9	A
	Right Turn	20	22	107.5%	0.3	1.1	0.3	A
	Subtotal	810	806	99.5%	0.1	3.0	0.3	A
Total		1040	1038	99.8%	0.1	7.0	0.5	A

SimTraffic Post-Processor
Average Results from 20 Runs
Volume and Delay by Movement

Caltrain Electrification
2020 No Project Conditions
AM Peak Hour

Intersection

Delaware Ave/25th Ave

Signalized

Direction	Movement	Volume (veh/hr)			GEH	Total Delay (sec/veh)		
		Demand	Served	% Served		Average	Std. Dev.	LOS
NB	Left Turn	30	29	98.0%	0.1	34.7	9.2	C
	Through	20	23	113.5%	0.6	16.8	6.0	B
	Right Turn							
	Subtotal	50	52	104.2%	0.3	26.8	6.2	C
SB	Left Turn							
	Through	30	26	87.7%	0.7	20.4	9.6	C
	Right Turn	590	590	100.0%	0.0	4.8	0.5	A
	Subtotal	620	617	99.4%	0.1	5.5	0.7	A
EB	Left Turn	590	588	99.7%	0.1	27.5	2.6	C
	Through							
	Right Turn	40	40	100.5%	0.0	10.5	2.0	B
	Subtotal	630	629	99.8%	0.1	26.4	2.4	C
WB	Left Turn							
	Through							
	Right Turn							
	Subtotal							
Total		1300	1297	99.8%	0.1	16.4	0.8	B

Intersection

El Camino Real/25th Ave

Signalized

Direction	Movement	Volume (veh/hr)			GEH	Total Delay (sec/veh)		
		Demand	Served	% Served		Average	Std. Dev.	LOS
NB	Left Turn	70	65	92.9%	0.6	80.0	16.5	E
	Through	1020	1039	101.9%	0.6	24.9	1.3	C
	Right Turn	330	325	98.3%	0.3	28.1	2.9	C
	Subtotal	1420	1429	100.6%	0.2	28.2	1.6	C
SB	Left Turn	80	79	98.3%	0.2	53.0	10.4	D
	Through	1070	1071	100.1%	0.0	20.9	0.7	C
	Right Turn	60	58	96.7%	0.3	21.4	2.8	C
	Subtotal	1210	1207	99.8%	0.1	23.0	1.1	C
EB	Left Turn	150	152	101.0%	0.1	42.6	6.1	D
	Through	220	221	100.4%	0.1	74.5	10.6	E
	Right Turn	40	41	101.8%	0.1	31.4	9.7	C
	Subtotal	410	413	100.7%	0.1	58.5	8.1	E
WB	Left Turn	560	568	101.4%	0.3	50.0	9.8	D
	Through	130	136	104.4%	0.5	61.5	12.0	E
	Right Turn	100	102	101.9%	0.2	38.2	7.3	D
	Subtotal	790	806	102.0%	0.6	50.5	9.3	D
Total		3830	3855	100.6%	0.4	34.5	1.6	C

SimTraffic Post-Processor
Average Results from 20 Runs
Volume and Delay by Movement

Caltrain Electrification
2020 No Project Conditions
AM Peak Hour

Intersection El Camino Real/31st Street

Signalized

Direction	Movement	Volume (veh/hr)			GEH	Total Delay (sec/veh)		
		Demand	Served	% Served		Average	Std. Dev.	LOS
NB	Left Turn	70	67	95.3%	0.4	61.6	14.9	E
	Through	1370	1374	100.3%	0.1	19.9	0.8	B
	Right Turn	120	117	97.3%	0.3	2.4	0.3	A
	Subtotal	1560	1558	99.9%	0.1	20.4	0.9	C
SB	Left Turn	60	57	94.8%	0.4	54.7	14.5	D
	Through	1280	1290	100.8%	0.3	22.1	1.2	C
	Right Turn	120	117	97.8%	0.2	16.3	2.6	B
	Subtotal	1460	1465	100.3%	0.1	22.9	1.3	C
EB	Left Turn	120	112	93.3%	0.7	40.1	5.1	D
	Through	50	51	101.6%	0.1	52.5	10.8	D
	Right Turn	160	164	102.6%	0.3	6.7	0.7	A
	Subtotal	330	327	99.1%	0.2	25.2	3.6	C
WB	Left Turn	20	19	95.0%	0.2	20.1	3.0	C
	Through	60	63	104.3%	0.3	17.8	2.7	B
	Right Turn	60	65	108.0%	0.6	12.8	1.1	B
	Subtotal	140	146	104.6%	0.5	15.9	1.4	B
Total		3490	3496	100.2%	0.1	21.7	1.1	C

Intersection El Camino Real/Hillsdale Blvd

Signalized

Direction	Movement	Volume (veh/hr)			GEH	Total Delay (sec/veh)		
		Demand	Served	% Served		Average	Std. Dev.	LOS
NB	Left Turn							
	Through							
	Right Turn							
	Subtotal							
SB	Left Turn	350	361	103.1%	0.6	36.8	1.9	D
	Through							
	Right Turn	80	81	101.1%	0.1	6.0	1.0	A
	Subtotal	430	442	102.7%	0.6	31.1	1.7	C
EB	Left Turn							
	Through	460	473	102.8%	0.6	63.1	14.6	E
	Right Turn	90	87	96.7%	0.3	26.4	10.8	C
	Subtotal	550	560	101.8%	0.4	57.4	14.1	E
WB	Left Turn	410	384	93.8%	1.3	15.0	1.3	B
	Through	720	687	95.4%	1.3	12.5	0.7	B
	Right Turn							
	Subtotal	1130	1071	94.8%	1.8	13.4	0.5	B
Total		3010	2966	98.5%	0.8	77.6	4.0	E

SimTraffic Post-Processor
Average Results from 20 Runs
Volume and Delay by Movement

Caltrain Electrification
2020 No Project Conditions
AM Peak Hour

Intersection **Curtiss Street/Hillsdale Blvd**

Signalized

Direction	Movement	Volume (veh/hr)			GEH	Total Delay (sec/veh)		
		Demand	Served	% Served		Average	Std. Dev.	LOS
NB	Left Turn	130	128	98.7%	0.1	45.7	3.3	D
	Through	10	9	93.0%	0.2	43.3	10.9	D
	Right Turn	130	133	102.6%	0.3	25.7	3.0	C
	Subtotal	270	271	100.4%	0.1	35.7	2.8	D
SB	Left Turn	40	39	97.3%	0.2	37.7	7.8	D
	Through	10	9	86.0%	0.5	39.9	17.6	D
	Right Turn	40	40	99.5%	0.0	28.6	7.8	C
	Subtotal	90	87	97.0%	0.3	33.4	5.8	C
EB	Left Turn	10	11	111.0%	0.3	32.5	9.4	C
	Through	1130	1146	101.4%	0.5	11.8	1.6	B
	Right Turn	90	87	96.9%	0.3	11.2	1.2	B
	Subtotal	1230	1244	101.1%	0.4	12.0	1.6	B
WB	Left Turn	40	40	99.5%	0.0	68.8	23.1	E
	Through	1200	1159	96.6%	1.2	47.6	19.6	D
	Right Turn	30	32	105.0%	0.3	45.0	21.3	D
	Subtotal	1270	1231	96.9%	1.1	48.3	19.7	D
Total		2860	2833	99.1%	0.5	30.7	9.3	C

SimTraffic Post-Processor
Average Results from 20 Runs
Volume and Delay by Movement

Caltrain Electrification
2020 No Project Conditions
AM Peak Hour

Intersection

El Camino Real/Ralston Avenue

Signalized

Direction	Movement	Volume (veh/hr)			GEH	Total Delay (sec/veh)		
		Demand	Served	% Served		Average	Std. Dev.	LOS
NB	Left Turn	90	84	93.8%	0.6	180.9	77.6	F
	Through	720	696	96.7%	0.9	167.4	78.6	F
	Right Turn	190	184	96.9%	0.4	27.0	29.1	C
	Subtotal	1000	965	96.5%	1.1	142.0	69.0	F
SB	Left Turn	380	366	96.2%	0.7	236.4	32.9	F
	Through	930	916	98.5%	0.5	63.8	11.3	E
	Right Turn	90	88	97.8%	0.2	26.2	9.1	C
	Subtotal	1400	1370	97.8%	0.8	107.5	15.1	F
EB	Left Turn	160	151	94.6%	0.7	261.9	43.6	F
	Through	780	714	91.6%	2.4	291.4	43.7	F
	Right Turn	170	159	93.2%	0.9	321.0	48.1	F
	Subtotal	1110	1024	92.3%	2.6	291.7	44.2	F
WB	Left Turn	160	152	95.2%	0.6	55.3	2.0	E
	Through	540	532	98.5%	0.4	84.8	11.1	F
	Right Turn	170	171	100.5%	0.1	11.0	0.9	B
	Subtotal	870	855	98.3%	0.5	64.8	7.0	E
Total		4380	4214	96.2%	2.5	151.4	9.5	F

Intersection

El Camino Real/San Carlos Avenue-Caltrain Station

Signalized

Direction	Movement	Volume (veh/hr)			GEH	Total Delay (sec/veh)		
		Demand	Served	% Served		Average	Std. Dev.	LOS
NB	Left Turn	90	84	93.1%	0.7	49.3	1.4	D
	Through	650	660	101.6%	0.4	16.3	0.9	B
	Right Turn	20	22	112.0%	0.5	15.0	3.0	B
	Subtotal	760	767	100.9%	0.2	19.9	1.0	B
SB	Left Turn	20	18	89.5%	0.5	47.2	5.5	D
	Through	870	874	100.4%	0.1	19.5	1.0	B
	Right Turn	280	278	99.4%	0.1	8.5	0.4	A
	Subtotal	1170	1170	100.0%	0.0	17.3	0.7	B
EB	Left Turn	500	493	98.5%	0.3	26.1	1.3	C
	Through	40	49	123.3%	1.4	27.9	3.4	C
	Right Turn	220	217	98.6%	0.2	23.8	2.1	C
	Subtotal	760	759	99.8%	0.0	25.5	1.3	C
WB	Left Turn	40	37	92.3%	0.5	69.0	11.5	E
	Through	40	39	96.3%	0.2	56.2	9.5	E
	Right Turn	40	38	94.0%	0.4	19.7	3.9	B
	Subtotal	120	113	94.2%	0.6	48.2	6.4	D
Total		2810	2808	99.9%	0.0	21.5	0.4	C

SimTraffic Post-Processor
Average Results from 20 Runs
Volume and Delay by Movement

Caltrain Electrification
2020 No Project Conditions
AM Peak Hour

Intersection California/Broadway

Unsignalized

Direction	Movement	Volume (veh/hr)			GEH	Total Delay (sec/veh)		
		Demand	Served	% Served		Average	Std. Dev.	LOS
NB	Left Turn	20	11	53.5%	2.4	914.5	245.9	F
	Through	30	17	56.7%	2.7	824.2	251.5	F
	Right Turn	90	55	61.2%	4.1	808.2	237.8	F
	Subtotal	140	83	59.1%	5.4	824.8	237.9	F
SB	Left Turn	30	27	91.0%	0.5	377.0	231.9	F
	Through	20	19	95.0%	0.2	414.0	295.5	F
	Right Turn	20	22	107.5%	0.3	357.7	276.3	F
	Subtotal	70	68	96.9%	0.3	378.5	255.9	F
EB	Left Turn	30	22	74.3%	1.5	76.0	13.6	F
	Through	480	375	78.1%	5.1	79.7	13.1	F
	Right Turn	70	57	80.7%	1.7	75.1	18.4	F
	Subtotal	580	454	78.2%	5.6	78.9	13.2	F
WB	Left Turn	70	66	94.9%	0.4	24.1	6.5	C
	Through	260	250	96.3%	0.6	10.4	2.4	B
	Right Turn	30	29	96.3%	0.2	0.5	0.4	A
	Subtotal	360	346	96.0%	0.8	12.2	3.0	B
Total		1150	950	82.6%	6.2	138.6	33.5	F

Intersection Arguello Street/Brewster Ave

Signalized

Direction	Movement	Volume (veh/hr)			GEH	Total Delay (sec/veh)		
		Demand	Served	% Served		Average	Std. Dev.	LOS
NB	Left Turn	20	20	100.0%	0.0	45.7	7.2	D
	Through	110	108	97.8%	0.2	27.5	4.1	C
	Right Turn	20	20	97.5%	0.1	4.7	0.6	A
	Subtotal	150	147	98.1%	0.2	26.9	3.3	C
SB	Left Turn	40	39	98.5%	0.1	66.1	15.0	E
	Through	140	132	94.2%	0.7	52.6	16.7	D
	Right Turn	140	141	100.9%	0.1	41.3	16.9	D
	Subtotal	320	313	97.7%	0.4	49.2	16.3	D
EB	Left Turn	80	49	61.6%	3.8	42.5	90.6	D
	Through	500	315	62.9%	9.2	35.5	31.6	D
	Right Turn	50	32	64.8%	2.7	13.0	33.9	B
	Subtotal	630	396	62.9%	10.3	34.1	33.3	C
WB	Left Turn	30	28	94.3%	0.3	41.2	6.0	D
	Through	140	137	98.1%	0.2	45.0	5.4	D
	Right Turn	20	22	107.5%	0.3	25.7	8.0	C
	Subtotal	190	187	98.5%	0.2	42.2	4.9	D
Total		1290	1043	80.9%	7.2	36.9	10.1	D

Intersection El Camino Real/Broadway

Signalized

Direction	Movement	Volume (veh/hr)			GEH	Total Delay (sec/veh)		
		Demand	Served	% Served		Average	Std. Dev.	LOS
NB	Left Turn	170	170	100.0%	0.0	85.0	30.9	F
	Through	1070	1091	102.0%	0.6	35.9	5.8	D
	Right Turn	80	79	99.1%	0.1	64.8	19.1	E
	Subtotal	1320	1341	101.6%	0.6	44.0	6.8	D
SB	Left Turn	110	105	95.4%	0.5	160.9	55.0	F
	Through	1000	1006	100.6%	0.2	31.0	2.5	C
	Right Turn	10	11	107.0%	0.2	19.1	7.5	B
	Subtotal	1120	1122	100.2%	0.1	43.0	5.9	D
EB	Left Turn	10	6	64.0%	1.3	181.9	32.9	F
	Through	390	268	68.7%	6.7	187.5	31.0	F
	Right Turn	290	203	69.9%	5.6	155.3	27.7	F
	Subtotal	690	477	69.1%	8.8	173.8	29.1	F
WB	Left Turn	30	28	92.0%	0.4	33.4	5.6	C
	Through	190	179	94.2%	0.8	23.0	1.6	C
	Right Turn	80	78	96.9%	0.3	18.6	2.4	B
	Subtotal	300	284	94.7%	0.9	22.8	1.5	C
Total		3430	3223	94.0%	3.6	60.6	6.1	E

Intersection Arguello St/Marshall

Signalized

Direction	Movement	Volume (veh/hr)			GEH	Total Delay (sec/veh)		
		Demand	Served	% Served		Average	Std. Dev.	LOS
NB	Left Turn	50	48	95.6%	0.3	77.4	46.4	E
	Through	80	84	104.5%	0.4	62.1	44.5	E
	Right Turn	20	21	106.5%	0.3	47.3	35.5	D
	Subtotal	150	153	101.8%	0.2	64.8	43.7	E
SB	Left Turn	50	42	84.4%	1.1	76.9	32.1	E
	Through	130	117	89.6%	1.2	61.8	30.3	E
	Right Turn	40	37	92.5%	0.5	56.3	32.6	E
	Subtotal	220	196	89.0%	1.7	64.1	29.7	E
EB	Left Turn	40	29	73.3%	1.8	14.7	3.7	B
	Through	440	333	75.8%	5.4	6.9	0.6	A
	Right Turn	120	93	77.3%	2.6	1.5	0.4	A
	Subtotal	600	455	75.9%	6.3	6.3	0.6	A
WB	Left Turn	30	24	80.3%	1.1	101.6	29.9	F
	Through	270	261	96.8%	0.5	94.9	25.1	F
	Right Turn	30	33	110.3%	0.6	4.8	3.2	A
	Subtotal	330	319	96.5%	0.6	85.9	22.8	F
Total		1300	1122	86.3%	5.1	47.2	12.1	D

SimTraffic Post-Processor
Average Results from 20 Runs
Volume and Delay by Movement

Caltrain Electrification
2020 No Project Conditions
AM Peak Hour

Intersection

El Camino Real/James

Signalized

Direction	Movement	Volume (veh/hr)			GEH	Total Delay (sec/veh)		
		Demand	Served	% Served		Average	Std. Dev.	LOS
NB	Left Turn	179	165	92.4%	1.0	60.1	10.4	E
	Through	1189	1151	96.8%	1.1	24.4	1.6	C
	Right Turn	63	60	95.9%	0.3	9.9	0.4	A
	Subtotal	1431	1377	96.2%	1.4	28.1	2.2	C
SB	Left Turn	95	84	88.8%	1.1	60.3	11.0	E
	Through	1179	1056	89.6%	3.7	32.1	3.6	C
	Right Turn	116	99	85.1%	1.7	16.1	2.4	B
	Subtotal	1390	1239	89.1%	4.2	32.8	3.8	C
EB	Left Turn	147	139	94.7%	0.7	34.1	2.7	C
	Through	95	86	90.2%	1.0	17.6	1.6	B
	Right Turn	179	163	91.1%	1.2	17.2	2.0	B
	Subtotal	421	388	92.1%	1.6	23.4	1.3	C
WB	Left Turn	74	57	76.8%	2.1	23.8	3.6	C
	Through	116	90	77.9%	2.5	26.7	3.9	C
	Right Turn	53	41	77.5%	1.7	23.0	5.9	C
	Subtotal	243	188	77.5%	3.7	25.2	2.9	C
Total		3485	3192	91.6%	5.1	29.2	2.1	C

Intersection

El Camino Real/Atherton Avenue-Fair Oaks Lane

Signalized

Direction	Movement	Volume (veh/hr)			GEH	Total Delay (sec/veh)		
		Demand	Served	% Served		Average	Std. Dev.	LOS
NB	Left Turn	80	76	94.5%	0.5	52.7	5.2	D
	Through	790	801	101.4%	0.4	19.7	1.2	B
	Right Turn	30	30	100.3%	0.0	19.1	2.3	B
	Subtotal	900	907	100.8%	0.2	22.4	1.0	C
SB	Left Turn	80	74	93.0%	0.6	48.2	3.6	D
	Through	1690	1656	98.0%	0.8	40.3	6.9	D
	Right Turn	180	175	97.3%	0.4	49.8	9.4	D
	Subtotal	1950	1906	97.7%	1.0	41.5	6.9	D
EB	Left Turn	120	117	97.5%	0.3	37.6	3.3	D
	Through	80	84	104.5%	0.4	35.3	2.5	D
	Right Turn	140	136	97.4%	0.3	21.5	2.0	C
	Subtotal	340	337	99.1%	0.2	30.5	2.3	C
WB	Left Turn	80	83	103.4%	0.3	71.5	17.0	E
	Through	130	135	104.0%	0.5	66.7	17.2	E
	Right Turn	70	73	103.7%	0.3	38.9	14.4	D
	Subtotal	280	291	103.8%	0.6	61.0	17.0	E
Total		3470	3440	99.1%	0.5	37.1	3.7	D

Intersection

El Camino Real/Watkins Avenue

Unsignalized

Direction	Movement	Volume (veh/hr)			GEH	Total Delay (sec/veh)		
		Demand	Served	% Served		Average	Std. Dev.	LOS
NB	Left Turn							
	Through	830	829	99.9%	0.0	0.9	0.1	A
	Right Turn	70	73	104.0%	0.3	1.6	0.2	A
	Subtotal	900	902	100.2%	0.1	1.0	0.1	A
SB	Left Turn	70	67	95.4%	0.4	10.0	0.9	A
	Through	1840	1828	99.3%	0.3	4.9	0.3	A
	Right Turn							
	Subtotal	1910	1895	99.2%	0.4	5.0	0.3	A
EB	Left Turn							
	Through							
	Right Turn							
	Subtotal							
WB	Left Turn	70	74	105.9%	0.5	44.4	9.6	E
	Through							
	Right Turn	70	73	104.1%	0.3	26.2	9.5	D
	Subtotal	140	147	105.0%	0.6	35.3	9.4	E
Total		2950	2943	99.8%	0.1	5.3	0.5	A

SimTraffic Post-Processor
Average Results from 20 Runs
Volume and Delay by Movement

Caltrain Electrification
2020 No Project Conditions
AM Peak Hour

Intersection **El Camino Real/Glenwood**

Signalized

Direction	Movement	Volume (veh/hr)			GEH	Total Delay (sec/veh)		
		Demand	Served	% Served		Average	Std. Dev.	LOS
NB	Left Turn	70	68	97.4%	0.2	55.8	4.4	E
	Through	740	733	99.0%	0.3	12.2	0.7	B
	Right Turn	40	41	102.3%	0.1	6.0	0.8	A
	Subtotal	850	842	99.0%	0.3	15.5	0.8	B
SB	Left Turn	100	94	94.1%	0.6	86.0	19.2	F
	Through	1360	1319	97.0%	1.1	76.0	19.7	E
	Right Turn	470	463	98.4%	0.3	20.0	6.8	B
	Subtotal	1930	1875	97.2%	1.3	62.7	16.2	E
EB	Left Turn	260	261	100.4%	0.1	85.5	23.5	F
	Through	150	157	104.3%	0.5	89.6	24.1	F
	Right Turn	100	102	101.6%	0.2	56.8	23.4	E
	Subtotal	510	519	101.8%	0.4	81.1	23.5	F
WB	Left Turn	90	93	103.8%	0.4	54.7	5.1	D
	Through	190	197	103.7%	0.5	56.3	4.8	E
	Right Turn	20	19	95.0%	0.2	47.5	10.1	D
	Subtotal	300	309	103.1%	0.5	55.2	4.6	E
Total		3590	3546	98.8%	0.7	53.6	11.1	D

Intersection **El Camino Real/Oak Grove**

Signalized

Direction	Movement	Volume (veh/hr)			GEH	Total Delay (sec/veh)		
		Demand	Served	% Served		Average	Std. Dev.	LOS
NB	Left Turn	90	85	94.9%	0.5	36.4	5.2	D
	Through	740	735	99.3%	0.2	7.0	0.8	A
	Right Turn	80	77	96.1%	0.3	3.7	0.4	A
	Subtotal	910	897	98.6%	0.4	9.5	0.9	A
SB	Left Turn	110	102	92.7%	0.8	110.2	13.2	F
	Through	1370	1309	95.5%	1.7	88.6	16.5	F
	Right Turn	70	67	95.3%	0.4	77.4	15.2	E
	Subtotal	1550	1478	95.3%	1.9	89.6	16.1	F
EB	Left Turn	70	68	96.4%	0.3	67.4	6.4	E
	Through	180	178	98.7%	0.2	46.6	4.0	D
	Right Turn	20	22	108.5%	0.4	30.8	5.6	C
	Subtotal	270	267	98.8%	0.2	50.5	3.8	D
WB	Left Turn	110	106	96.5%	0.4	50.1	4.3	D
	Through	200	202	101.0%	0.1	39.5	3.8	D
	Right Turn	40	41	103.5%	0.2	9.3	2.1	A
	Subtotal	350	350	99.9%	0.0	39.2	3.2	D
Total		3080	2991	97.1%	1.6	56.3	8.4	E

SimTraffic Post-Processor
Average Results from 20 Runs
Volume and Delay by Movement

Caltrain Electrification
2020 No Project Conditions
AM Peak Hour

Intersection El Camino Real/Santa Cruz Ave

Signalized

Direction	Movement	Volume (veh/hr)			GEH	Total Delay (sec/veh)		
		Demand	Served	% Served		Average	Std. Dev.	LOS
NB	Left Turn							
	Through	780	789	101.2%	0.3	4.2	0.3	A
	Right Turn	50	45	90.4%	0.7	3.1	0.6	A
	Subtotal	830	834	100.5%	0.1	4.1	0.3	A
SB	Left Turn							
	Through	1410	1351	95.8%	1.6	37.5	3.3	D
	Right Turn	90	84	92.9%	0.7	22.2	2.2	C
	Subtotal	1500	1435	95.6%	1.7	36.6	3.2	D
EB	Left Turn	100	100	99.6%	0.0	50.5	12.8	D
	Through	270	269	99.6%	0.1	60.3	18.4	E
	Right Turn	180	169	94.0%	0.8	46.0	10.3	D
	Subtotal	550	538	97.8%	0.5	54.1	15.1	D
WB	Left Turn	110	88	79.8%	2.2	35.6	2.2	D
	Through	70	60	85.4%	1.3	38.1	4.8	D
	Right Turn	30	24	81.0%	1.1	20.0	5.4	B
	Subtotal	210	172	81.9%	2.8	34.3	2.8	C
Total		3090	2978	96.4%	2.0	30.5	3.8	C

Intersection Merril St/Santa Cruz Ave

Unsignalized

Direction	Movement	Volume (veh/hr)			GEH	Total Delay (sec/veh)		
		Demand	Served	% Served		Average	Std. Dev.	LOS
NB	Left Turn	70	30	43.4%	5.6	6.3	0.9	A
	Through	20	12	57.5%	2.1	6.6	1.0	A
	Right Turn	10	4	39.0%	2.3	3.8	0.5	A
	Subtotal	100	46	45.8%	6.3	6.1	0.7	A
SB	Left Turn	10	8	80.0%	0.7	8.1	1.4	A
	Through	30	33	108.3%	0.4	9.2	0.8	A
	Right Turn	90	89	99.1%	0.1	5.8	0.5	A
	Subtotal	130	130	99.8%	0.0	6.8	0.6	A
EB	Left Turn	80	79	98.4%	0.1	14.2	1.2	B
	Through	30	36	121.0%	1.1	13.0	0.9	B
	Right Turn	210	205	97.4%	0.4	12.4	1.0	B
	Subtotal	320	320	99.9%	0.0	12.9	0.8	B
WB	Left Turn	10	10	101.0%	0.0	3.5	0.5	A
	Through	50	49	97.8%	0.2	4.2	0.4	A
	Right Turn	10	9	94.0%	0.2	3.0	0.6	A
	Subtotal	70	68	97.7%	0.2	3.9	0.3	A
Total		620	564	90.9%	2.3	9.9	0.6	A

SimTraffic Post-Processor
Average Results from 20 Runs
Volume and Delay by Movement

Caltrain Electrification
2020 No Project Conditions
AM Peak Hour

Intersection Ravenswood Ave/Laurel St

Signalized

Direction	Movement	Volume (veh/hr)			GEH	Total Delay (sec/veh)		
		Demand	Served	% Served		Average	Std. Dev.	LOS
NB	Left Turn	179	170	95.2%	0.7	35.7	3.8	D
	Through	74	65	87.4%	1.1	22.1	3.7	C
	Right Turn	32	31	97.5%	0.1	17.1	2.1	B
	Subtotal	285	266	93.4%	1.1	30.3	3.1	C
SB	Left Turn	179	164	91.7%	1.1	279.8	113.2	F
	Through	179	158	88.3%	1.6	279.3	120.9	F
	Right Turn	84	75	89.4%	1.0	280.7	121.7	F
	Subtotal	442	397	89.9%	2.2	279.6	117.0	F
EB	Left Turn	42	35	84.0%	1.1	43.0	4.0	D
	Through	832	753	90.5%	2.8	34.8	2.4	C
	Right Turn	116	109	94.1%	0.6	32.8	4.3	C
	Subtotal	990	897	90.6%	3.0	34.9	2.3	C
WB	Left Turn	21	19	88.1%	0.6	54.3	7.1	D
	Through	589	565	95.9%	1.0	14.5	1.1	B
	Right Turn	21	20	93.8%	0.3	10.3	2.6	B
	Subtotal	631	603	95.6%	1.1	15.6	1.2	B
Total		2348	2164	92.2%	3.9	73.4	20.5	E

Intersection

High Street/University Ave

Signalized

Direction	Movement	Volume (veh/hr)			GEH	Total Delay (sec/veh)		
		Demand	Served	% Served		Average	Std. Dev.	LOS
NB	Left Turn							
	Through							
	Right Turn							
	Subtotal							
SB	Left Turn	30	31	102.0%	0.1	23.5	6.4	C
	Through	50	54	107.8%	0.5	10.3	1.4	B
	Right Turn	220	220	99.9%	0.0	11.1	1.1	B
	Subtotal	300	304	101.4%	0.2	12.2	1.3	B
EB	Left Turn							
	Through	490	495	101.0%	0.2	10.7	0.8	B
	Right Turn	280	283	101.1%	0.2	3.7	0.4	A
	Subtotal	770	778	101.1%	0.3	8.2	0.6	A
WB	Left Turn	30	27	89.3%	0.6	18.2	2.8	B
	Through	540	535	99.1%	0.2	11.4	0.9	B
	Right Turn							
	Subtotal	570	562	98.6%	0.3	11.7	0.9	B
Total		1640	1645	100.3%	0.1	10.1	0.3	B

Intersection

Showers Drive/Pacchetti Way

Signalized

Direction	Movement	Volume (veh/hr)			GEH	Total Delay (sec/veh)		
		Demand	Served	% Served		Average	Std. Dev.	LOS
NB	Left Turn	20	19	93.5%	0.3	21.5	1.9	C
	Through	20	20	100.0%	0.0	1.1	0.7	A
	Right Turn							
	Subtotal	40	39	96.8%	0.2	11.0	1.9	B
SB	Left Turn							
	Through	70	75	107.0%	0.6	2.6	0.6	A
	Right Turn	30	30	98.7%	0.1	1.3	0.5	A
	Subtotal	100	105	104.5%	0.4	2.2	0.5	A
EB	Left Turn							
	Through							
	Right Turn	10	10	95.0%	0.2	2.4	0.3	A
	Subtotal	10	10	95.0%	0.2	2.4	0.3	A
WB	Left Turn							
	Through							
	Right Turn							
	Subtotal							
Total		150	153	101.8%	0.2	4.4	0.5	A

Intersection Hope Street/Evelyn Ave

Signalized

Direction	Movement	Volume (veh/hr)			GEH	Total Delay (sec/veh)		
		Demand	Served	% Served		Average	Std. Dev.	LOS
NB	Left Turn	40	38	94.0%	0.4	20.5	3.7	C
	Through							
	Right Turn	70	67	96.3%	0.3	5.1	0.4	A
	Subtotal	110	105	95.5%	0.5	10.6	1.3	B
SB	Left Turn							
	Through							
	Right Turn							
	Subtotal							
EB	Left Turn							
	Through	30	32	105.0%	0.3	1.9	0.6	A
	Right Turn	40	38	95.5%	0.3	1.2	0.3	A
	Subtotal	70	70	99.6%	0.0	1.5	0.2	A
WB	Left Turn	60	56	93.3%	0.5	2.2	0.4	A
	Through	310	305	98.5%	0.3	2.3	0.2	A
	Right Turn							
	Subtotal	370	361	97.6%	0.5	2.2	0.2	A
Total		550	536	97.4%	0.6	3.8	0.3	A

Intersection Castro Street/Villa Street

Signalized

Direction	Movement	Volume (veh/hr)			GEH	Total Delay (sec/veh)		
		Demand	Served	% Served		Average	Std. Dev.	LOS
NB	Left Turn	20	20	102.0%	0.1	17.5	2.7	B
	Through	180	177	98.4%	0.2	10.7	1.0	B
	Right Turn	40	45	112.5%	0.8	6.5	2.0	A
	Subtotal	240	243	101.1%	0.2	10.5	0.9	B
SB	Left Turn	140	141	100.7%	0.1	10.2	0.6	B
	Through	220	228	103.6%	0.5	6.5	0.5	A
	Right Turn	10	11	107.0%	0.2	3.9	1.8	A
	Subtotal	370	380	102.6%	0.5	7.8	0.4	A
EB	Left Turn	50	45	90.4%	0.7	19.6	2.5	B
	Through	150	153	102.1%	0.3	15.2	1.0	B
	Right Turn	10	11	107.0%	0.2	9.1	3.7	A
	Subtotal	210	209	99.5%	0.1	15.9	1.3	B
WB	Left Turn	40	36	88.8%	0.7	19.6	2.4	B
	Through	180	178	99.1%	0.1	15.6	1.2	B
	Right Turn	40	35	88.5%	0.7	9.9	2.2	A
	Subtotal	260	249	95.9%	0.7	15.3	1.3	B
Total		1080	1081	100.1%	0.0	11.7	0.6	B

Intersection

Frances St/Evelyn Ave

Signalized

Direction	Movement	Volume (veh/hr)			GEH	Total Delay (sec/veh)		
		Demand	Served	% Served		Average	Std. Dev.	LOS
NB	Left Turn	20	18	90.0%	0.5	21.0	2.7	C
	Through	10	11	108.0%	0.2	14.3	5.5	B
	Right Turn	10	9	86.0%	0.5	5.6	2.6	A
	Subtotal	40	37	93.5%	0.4	15.5	2.7	B
SB	Left Turn	110	109	98.9%	0.1	20.3	2.7	C
	Through	30	29	98.0%	0.1	18.7	3.1	B
	Right Turn	90	90	99.8%	0.0	14.0	2.6	B
	Subtotal	230	228	99.1%	0.1	17.6	2.3	B
EB	Left Turn	40	42	104.0%	0.3	47.6	8.1	D
	Through	200	195	97.6%	0.3	13.9	1.2	B
	Right Turn	30	32	105.0%	0.3	7.9	1.5	A
	Subtotal	270	268	99.4%	0.1	18.5	2.1	B
WB	Left Turn	40	37	92.0%	0.5	46.0	5.5	D
	Through	550	569	103.4%	0.8	21.8	2.2	C
	Right Turn	110	112	102.0%	0.2	11.6	3.4	B
	Subtotal	700	718	102.5%	0.7	21.5	2.4	C
Total		1240	1251	100.9%	0.3	20.0	1.6	B

SimTraffic Post-Processor
Average Results from 20 Runs
Volume and Delay by Movement

Caltrain Electrification
2020 No Project Conditions
AM Peak Hour

Intersection Lawrence Expressway/Kifer Road

Signalized

Direction	Movement	Volume (veh/hr)			GEH	Total Delay (sec/veh)		
		Demand	Served	% Served		Average	Std. Dev.	LOS
NB	Left Turn	260	204	78.5%	3.7	165.4	11.6	F
	Through	4650	3536	76.0%	17.4	169.0	10.8	F
	Right Turn	550	432	78.5%	5.3	184.1	10.5	F
	Subtotal	5460	4172	76.4%	18.6	170.4	10.7	F
SB	Left Turn	230	232	100.7%	0.1	109.1	37.5	F
	Through	1440	1454	101.0%	0.4	19.9	1.3	B
	Right Turn	410	412	100.4%	0.1	14.1	1.2	B
	Subtotal	2080	2097	100.8%	0.4	28.7	5.2	C
EB	Left Turn	120	124	103.3%	0.4	62.9	6.4	E
	Through	150	150	100.1%	0.0	46.7	2.1	D
	Right Turn	210	225	107.2%	1.0	2.0	0.2	A
	Subtotal	480	499	104.0%	0.9	30.6	2.2	C
WB	Left Turn	80	71	89.3%	1.0	62.9	4.0	E
	Through	200	197	98.7%	0.2	49.9	3.2	D
	Right Turn	160	160	99.9%	0.0	6.1	1.7	A
	Subtotal	440	429	97.4%	0.6	35.8	2.0	D
Total		8460	7197	85.1%	14.3	111.4	5.7	F

Intersection Lawrence Expressway/Reed Ave-Monroe St

Signalized

Direction	Movement	Volume (veh/hr)			GEH	Total Delay (sec/veh)		
		Demand	Served	% Served		Average	Std. Dev.	LOS
NB	Left Turn	170	132	77.6%	3.1	135.9	3.2	F
	Through	4720	3668	77.7%	16.2	114.9	4.5	F
	Right Turn	110	79	71.5%	3.2	92.4	3.4	F
	Subtotal	5000	3879	77.6%	16.8	115.2	4.4	F
SB	Left Turn	90	88	97.3%	0.3	68.4	6.0	E
	Through	1460	1492	102.2%	0.8	31.6	6.3	C
	Right Turn	180	182	101.0%	0.1	11.5	1.2	B
	Subtotal	1730	1761	101.8%	0.7	31.3	5.4	C
EB	Left Turn	430	296	68.8%	7.0	645.5	288.3	F
	Through	340	298	87.6%	2.4	88.4	35.4	F
	Right Turn	240	213	88.6%	1.8	26.1	19.8	C
	Subtotal	1010	806	79.8%	6.8	272.0	116.9	F
WB	Left Turn	200	208	104.1%	0.6	78.5	27.3	E
	Through	240	231	96.1%	0.6	63.5	35.8	E
	Right Turn	310	296	95.5%	0.8	103.1	177.4	F
	Subtotal	750	735	98.0%	0.6	82.7	87.9	F
Total		8490	7181	84.6%	14.8	107.3	11.7	F

SimTraffic Post-Processor
Average Results from 20 Runs
Volume and Delay by Movement

Caltrain Electrification
2020 No Project Conditions
AM Peak Hour

Intersection

El Camino Real/Railroad Avenue

Signalized

Direction	Movement	Volume (veh/hr)				Total Delay (sec/veh)		
		Demand	Served	% Served	GEH	Average	Std. Dev.	LOS
NB	Left Turn	210	198	94.1%	0.9	52.2	6.2	D
	Through	1080	1053	97.5%	0.8	12.9	0.5	B
	Right Turn	60	56	93.7%	0.5	11.8	0.9	B
	Subtotal	1350	1307	96.8%	1.2	18.8	1.2	B
SB	Left Turn	60	64	106.0%	0.5	36.2	3.9	D
	Through	400	403	100.6%	0.1	13.3	1.0	B
	Right Turn	100	105	104.6%	0.5	11.2	2.0	B
	Subtotal	560	571	101.9%	0.5	15.5	1.0	B
EB	Left Turn	10	9	94.0%	0.2	29.9	6.1	C
	Through	10	11	105.0%	0.2	19.7	5.9	B
	Right Turn	30	29	97.7%	0.1	7.5	0.5	A
	Subtotal	50	49	98.4%	0.1	14.4	2.1	B
WB	Left Turn	60	61	101.3%	0.1	31.0	3.5	C
	Through	20	20	100.5%	0.0	18.6	3.7	B
	Right Turn	50	51	102.4%	0.2	7.0	1.1	A
	Subtotal	130	132	101.6%	0.2	19.8	2.2	B
Total		2090	2059	98.5%	0.7	17.8	0.9	B

Intersection Santa Clara Street/Cahill Street

Signalized

Direction	Movement	Volume (veh/hr)			GEH	Total Delay (sec/veh)		
		Demand	Served	% Served		Average	Std. Dev.	LOS
NB	Left Turn	90	85	94.9%	0.5	32.6	2.3	C
	Through	10	18	180.0%	2.1	23.7	5.9	C
	Right Turn	120	123	102.6%	0.3	8.6	1.0	A
	Subtotal	220	227	103.0%	0.4	18.8	1.6	B
SB	Left Turn	10	9	91.0%	0.3	36.0	6.8	D
	Through	10	11	108.0%	0.2	40.2	9.6	D
	Right Turn	10	12	124.0%	0.7	14.1	4.4	B
	Subtotal	30	32	107.7%	0.4	29.1	5.7	C
EB	Left Turn	10	9	86.0%	0.5	139.9	84.9	F
	Through	540	545	100.8%	0.2	35.4	10.2	D
	Right Turn	70	74	105.4%	0.4	32.2	10.0	C
	Subtotal	620	627	101.1%	0.3	36.6	11.2	D
WB	Left Turn	280	274	97.8%	0.4	64.8	18.3	E
	Through	1150	1171	101.8%	0.6	12.2	8.8	B
	Right Turn	20	19	92.5%	0.3	15.9	21.7	B
	Subtotal	1450	1464	100.9%	0.4	22.1	10.7	C
Total		2320	2349	101.3%	0.6	25.8	7.1	C

Intersection San Fernando Street/Montgomery Street

Signalized

Direction	Movement	Volume (veh/hr)			GEH	Total Delay (sec/veh)		
		Demand	Served	% Served		Average	Std. Dev.	LOS
NB	Left Turn							
	Through							
	Right Turn							
	Subtotal							
SB	Left Turn	70	70	100.1%	0.0	37.1	3.7	D
	Through	490	496	101.2%	0.3	36.8	5.1	D
	Right Turn	10	11	113.0%	0.4	28.0	9.0	C
	Subtotal	570	577	101.3%	0.3	36.7	4.7	D
EB	Left Turn							
	Through	120	123	102.2%	0.2	7.0	0.8	A
	Right Turn	150	153	101.9%	0.2	6.2	0.9	A
	Subtotal	270	275	102.0%	0.3	6.6	0.6	A
WB	Left Turn	310	315	101.5%	0.3	17.7	2.0	B
	Through	280	291	103.9%	0.7	16.2	2.3	B
	Right Turn							
	Subtotal	590	606	102.6%	0.6	17.0	2.1	B
Total		1430	1458	102.0%	0.7	22.8	1.9	C

SimTraffic Post-Processor
Average Results from 20 Runs
Volume and Delay by Movement

Caltrain Electrification
2020 No Project Conditions
AM Peak Hour

Intersection

Lick Avenue-Shadow Run Drive/Alma Avenue

Signalized

Direction	Movement	Volume (veh/hr)			GEH	Total Delay (sec/veh)		
		Demand	Served	% Served		Average	Std. Dev.	LOS
NB	Left Turn	40	41	101.5%	0.1	32.4	3.5	C
	Through	40	43	107.5%	0.5	27.4	3.7	C
	Right Turn	20	20	98.5%	0.1	8.6	2.0	A
	Subtotal	100	103	103.3%	0.3	25.7	2.2	C
SB	Left Turn	70	67	95.4%	0.4	35.6	3.0	D
	Through	10	12	115.0%	0.5	23.9	7.5	C
	Right Turn	50	49	98.8%	0.1	5.2	2.0	A
	Subtotal	130	128	98.2%	0.2	22.9	2.8	C
EB	Left Turn	60	57	95.7%	0.3	32.1	3.4	C
	Through	480	485	101.0%	0.2	14.6	0.7	B
	Right Turn	10	12	122.0%	0.7	9.7	3.7	A
	Subtotal	550	555	100.8%	0.2	16.3	0.5	B
WB	Left Turn	30	30	98.7%	0.1	45.2	5.1	D
	Through	700	682	97.5%	0.7	25.6	1.7	C
	Right Turn	340	341	100.3%	0.1	27.0	2.4	C
	Subtotal	1070	1053	98.4%	0.5	26.6	1.7	C
Total		1850	1838	99.4%	0.3	23.2	1.1	C

Intersection 7th Street/Mission Bay

Signalized

Direction	Movement	Volume (veh/hr)			GEH	Total Delay (sec/veh)		
		Demand	Served	% Served		Average	Std. Dev.	LOS
NB	Left Turn	10	8	82.0%	0.6	29.7	8.1	C
	Through	810	810	100.0%	0.0	10.7	0.7	B
	Right Turn	50	52	103.0%	0.2	16.0	2.8	B
	Subtotal	870	870	100.0%	0.0	11.2	0.6	B
SB	Left Turn	40	33	82.5%	1.2	38.9	5.5	D
	Through	290	290	99.9%	0.0	6.6	0.8	A
	Right Turn	10	11	112.0%	0.4	3.7	1.6	A
	Subtotal	340	334	98.2%	0.3	9.7	1.2	A
EB	Left Turn							
	Through							
	Right Turn							
	Subtotal							
WB	Left Turn	30	29	95.7%	0.2	3.4	2.1	A
	Through							
	Right Turn	70	73	103.9%	0.3	0.9	0.2	A
	Subtotal	100	101	101.4%	0.1	1.6	0.6	A
Total		1310	1305	99.6%	0.1	10.1	0.5	B

Intersection Berry Street/Mission Bay

Signalized

Direction	Movement	Volume (veh/hr)			GEH	Total Delay (sec/veh)		
		Demand	Served	% Served		Average	Std. Dev.	LOS
NB	Left Turn							
	Through							
	Right Turn							
	Subtotal							
SB	Left Turn							
	Through							
	Right Turn	100	101	100.7%	0.1	3.1	1.5	A
	Subtotal	100	101	100.7%	0.1	3.1	1.5	A
EB	Left Turn	90	85	94.8%	0.5	0.4	0.7	A
	Through							
	Right Turn							
	Subtotal	90	85	94.8%	0.5	0.4	0.7	A
WB	Left Turn							
	Through							
	Right Turn							
	Subtotal							
Total		190	186	97.9%	0.3	1.9	1.1	A

Intersection Main Street/Maple Street

Unsignalized

Direction	Movement	Volume (veh/hr)			GEH	Total Delay (sec/veh)		
		Demand	Served	% Served		Average	Std. Dev.	LOS
NB	Left Turn							
	Through	460	446	97.0%	0.7	5.8	0.7	A
	Right Turn							
	Subtotal	460	446	97.0%	0.7	5.8	0.7	A
SB	Left Turn							
	Through	310	297	95.8%	0.7	8.9	2.2	A
	Right Turn							
	Subtotal	310	297	95.8%	0.7	8.9	2.2	A
EB	Left Turn							
	Through							
	Right Turn							
	Subtotal							
WB	Left Turn	10	0	0.0%	4.5	0.0	0.0	A
	Through							
	Right Turn	10	20	197.0%	2.5	39.3	19.1	E
	Subtotal	20	20	98.5%	0.1	39.3	19.1	E
Total		790	763	96.5%	1.0	7.9	1.4	A

Intersection Main Street/Beech Street

Unsignalized

Direction	Movement	Volume (veh/hr)			GEH	Total Delay (sec/veh)		
		Demand	Served	% Served		Average	Std. Dev.	LOS
NB	Left Turn	80	76	95.3%	0.4	4.0	0.8	A
	Through	280	271	96.8%	0.5	1.5	0.2	A
	Right Turn							
	Subtotal	360	347	96.5%	0.7	2.0	0.3	A
SB	Left Turn							
	Through	200	194	97.1%	0.4	1.3	0.3	A
	Right Turn	60	59	99.0%	0.1	0.7	0.3	A
	Subtotal	260	254	97.5%	0.4	1.2	0.3	A
EB	Left Turn	30	28	92.3%	0.4	10.0	2.7	A
	Through							
	Right Turn	60	62	104.0%	0.3	4.7	0.7	A
	Subtotal	90	90	100.1%	0.0	6.4	0.8	A
WB	Left Turn							
	Through							
	Right Turn							
	Subtotal							
Total		710	691	97.3%	0.7	2.3	0.2	A

Intersection Main Street/Middlefield Road

Signalized

Direction	Movement	Volume (veh/hr)			GEH	Total Delay (sec/veh)		
		Demand	Served	% Served		Average	Std. Dev.	LOS
NB	Left Turn	50	49	98.0%	0.1	53.6	6.8	D
	Through	390	381	97.8%	0.4	28.5	0.7	C
	Right Turn	30	33	110.7%	0.6	7.3	2.6	A
	Subtotal	470	464	98.6%	0.3	29.6	1.0	C
SB	Left Turn	30	26	85.3%	0.8	41.4	6.8	D
	Through	240	231	96.2%	0.6	25.9	2.3	C
	Right Turn	50	53	105.2%	0.4	2.9	0.4	A
	Subtotal	320	309	96.6%	0.6	23.3	2.1	C
EB	Left Turn	60	56	93.2%	0.5	28.0	3.0	C
	Through	330	328	99.4%	0.1	29.1	1.8	C
	Right Turn	50	49	97.8%	0.2	24.2	4.7	C
	Subtotal	440	433	98.4%	0.3	28.5	2.0	C
WB	Left Turn	20	17	84.5%	0.7	4.1	4.8	A
	Through	110	116	105.0%	0.5	4.0	1.0	A
	Right Turn	70	67	95.9%	0.4	1.3	0.7	A
	Subtotal	200	200	99.8%	0.0	3.1	0.7	A
Total		1430	1405	98.3%	0.7	24.2	0.7	C

Intersection Fair Oaks/Middlefield Road

Unsignalized

Direction	Movement	Volume (veh/hr)			GEH	Total Delay (sec/veh)		
		Demand	Served	% Served		Average	Std. Dev.	LOS
NB	Left Turn	20	18	91.0%	0.4	187.2	157.5	F
	Through	10	9	90.0%	0.3	168.4	151.1	F
	Right Turn	200	191	95.7%	0.6	98.9	92.4	F
	Subtotal	230	219	95.0%	0.8	109.0	99.2	F
SB	Left Turn	20	15	74.5%	1.2	731.7	244.3	F
	Through	70	55	77.9%	2.0	732.0	202.5	F
	Right Turn	50	40	79.4%	1.5	689.0	217.9	F
	Subtotal	140	109	77.9%	2.8	713.7	209.3	F
EB	Left Turn	10	7	71.0%	1.0	6.6	1.8	A
	Through	700	691	98.8%	0.3	4.7	0.5	A
	Right Turn	110	104	94.4%	0.6	3.2	0.6	A
	Subtotal	820	802	97.8%	0.6	4.5	0.5	A
WB	Left Turn	220	226	102.6%	0.4	23.3	6.4	C
	Through	440	445	101.0%	0.2	6.4	3.1	A
	Right Turn	20	19	93.0%	0.3	5.3	2.6	A
	Subtotal	680	689	101.3%	0.3	11.9	4.2	B
Total		1870	1819	97.3%	1.2	60.7	14.3	F

Intersection Watkins Avenue/Middlefield Road

Unsignalized

Direction	Movement	Volume (veh/hr)			GEH	Total Delay (sec/veh)		
		Demand	Served	% Served		Average	Std. Dev.	LOS
NB	Left Turn	70	70	100.0%	0.0	75.4	28.8	F
	Through							
	Right Turn	80	79	99.1%	0.1	31.9	19.4	D
	Subtotal	150	149	99.5%	0.1	52.5	24.5	F
SB	Left Turn							
	Through							
	Right Turn							
	Subtotal							
EB	Left Turn							
	Through	820	811	98.8%	0.3	5.0	0.3	A
	Right Turn	100	99	99.0%	0.1	3.8	0.3	A
	Subtotal	920	910	98.9%	0.3	4.9	0.3	A
WB	Left Turn	60	57	94.8%	0.4	15.9	2.8	C
	Through	610	618	101.3%	0.3	5.2	0.4	A
	Right Turn							
	Subtotal	670	675	100.7%	0.2	6.1	0.5	A
Total		1740	1734	99.6%	0.2	9.5	2.3	A

Intersection

Linden Avenue-Glenwood Avenue/Middlefield Road

Unsignalized

Direction	Movement	Volume (veh/hr)			GEH	Total Delay (sec/veh)		
		Demand	Served	% Served		Average	Std. Dev.	LOS
NB	Left Turn	70	67	95.6%	0.4	107.3	39.4	F
	Through	10	12	119.0%	0.6	89.0	42.2	F
	Right Turn	100	96	96.3%	0.4	43.1	21.4	E
	Subtotal	180	175	97.3%	0.4	70.9	30.0	F
SB	Left Turn	30	27	91.3%	0.5	55.9	13.1	F
	Through	10	12	124.0%	0.7	74.2	19.8	F
	Right Turn	40	39	97.8%	0.1	38.0	17.8	E
	Subtotal	80	79	98.6%	0.1	49.5	15.0	E
EB	Left Turn	50	46	91.4%	0.6	11.6	0.8	B
	Through	680	677	99.5%	0.1	8.9	0.4	A
	Right Turn	170	166	97.5%	0.3	7.6	0.5	A
	Subtotal	900	888	98.7%	0.4	8.8	0.4	A
WB	Left Turn	90	88	97.9%	0.2	16.7	2.3	C
	Through	560	559	99.9%	0.0	2.9	0.3	A
	Right Turn	10	13	129.0%	0.9	2.0	0.7	A
	Subtotal	660	660	100.0%	0.0	4.7	0.4	A
Total		1820	1803	99.0%	0.4	15.2	2.7	C

Intersection California Street/Rengstorff Avenue

Signalized

Direction	Movement	Volume (veh/hr)			GEH	Total Delay (sec/veh)		
		Demand	Served	% Served		Average	Std. Dev.	LOS
NB	Left Turn	60	57	95.2%	0.4	64.5	12.6	E
	Through	310	310	100.1%	0.0	23.0	1.2	C
	Right Turn	140	148	105.9%	0.7	18.5	1.9	B
	Subtotal	510	516	101.1%	0.2	26.3	2.2	C
SB	Left Turn	120	119	99.1%	0.1	78.5	11.2	E
	Through	210	206	98.2%	0.3	18.9	1.7	B
	Right Turn	60	59	97.5%	0.2	14.0	2.2	B
	Subtotal	390	384	98.4%	0.3	36.7	4.5	D
EB	Left Turn	50	47	94.8%	0.4	54.7	8.8	D
	Through	480	473	98.6%	0.3	22.2	1.0	C
	Right Turn	30	32	108.0%	0.4	19.3	3.4	B
	Subtotal	560	553	98.7%	0.3	24.9	1.6	C
WB	Left Turn	110	107	97.6%	0.2	91.2	18.0	F
	Through	420	429	102.1%	0.4	20.7	2.3	C
	Right Turn	120	121	100.4%	0.0	18.2	2.2	B
	Subtotal	650	657	101.0%	0.3	31.8	4.4	C
Total		2110	2109	99.9%	0.0	29.5	1.7	C

Intersection Pennsylvania Street/22nd Street

Unsignalized

Direction	Movement	Volume (veh/hr)			GEH	Total Delay (sec/veh)		
		Demand	Served	% Served		Average	Std. Dev.	LOS
NB	Left Turn	50	44	87.0%	1.0	7.0	0.5	A
	Through	190	174	91.7%	1.2	7.8	0.6	A
	Right Turn	40	35	88.0%	0.8	5.7	0.8	A
	Subtotal	280	253	90.3%	1.7	7.3	0.5	A
SB	Left Turn	20	10	47.5%	2.7	5.9	1.0	A
	Through	110	97	87.9%	1.3	6.5	0.4	A
	Right Turn	10	3	26.0%	2.9	3.8	1.6	A
	Subtotal	140	109	77.7%	2.8	6.4	0.4	A
EB	Left Turn	10	4	36.0%	2.5	4.8	1.4	A
	Through	40	31	77.5%	1.5	6.3	0.6	A
	Right Turn	70	70	99.9%	0.0	4.1	0.4	A
	Subtotal	120	105	87.1%	1.5	4.8	0.4	A
WB	Left Turn	100	105	105.0%	0.5	5.8	0.4	A
	Through	30	28	92.0%	0.4	6.0	0.5	A
	Right Turn	20	27	132.5%	1.3	4.0	0.4	A
	Subtotal	150	159	106.1%	0.7	5.5	0.4	A
Total		690	625	90.6%	2.5	6.3	0.3	A

Intersection Indiana Street/22nd Street

Unsignalized

Direction	Movement	Volume (veh/hr)			GEH	Total Delay (sec/veh)		
		Demand	Served	% Served		Average	Std. Dev.	LOS
NB	Left Turn	20	15	74.5%	1.2	5.3	0.8	A
	Through	70	60	85.6%	1.3	6.1	0.3	A
	Right Turn	60	49	81.7%	1.5	4.0	0.4	A
	Subtotal	150	124	82.5%	2.2	5.2	0.3	A
SB	Left Turn	10	7	72.0%	1.0	5.0	1.1	A
	Through	20	19	92.5%	0.3	5.8	0.5	A
	Right Turn	30	30	100.3%	0.0	3.9	0.4	A
	Subtotal	60	56	93.0%	0.6	4.7	0.3	A
EB	Left Turn	10	14	135.0%	1.0	4.4	0.4	A
	Through	70	66	93.9%	0.5	5.3	0.3	A
	Right Turn	10	10	103.0%	0.1	3.4	0.7	A
	Subtotal	90	90	99.4%	0.1	5.0	0.3	A
WB	Left Turn	10	6	60.0%	1.4	5.0	0.9	A
	Through	120	111	92.3%	0.9	5.5	0.3	A
	Right Turn	10	3	26.0%	2.9	3.2	1.8	A
	Subtotal	140	119	85.3%	1.8	5.4	0.3	A
Total		440	389	88.3%	2.5	5.1	0.2	A

SimTraffic Post-Processor
Average Results from 20 Runs
Volume and Delay by Movement

Caltrain Electrification
2020 No Project Conditions
PM Peak Hour

Intersection unnel Avenue/Blanken Avenue

Unsignalized

Direction	Movement	Volume (veh/hr)			GEH	Total Delay (sec/veh)		
		Demand	Served	% Served		Average	Std. Dev.	LOS
NB	Left Turn	30	30	101.0%	0.1	23.2	4.5	C
	Through	230	221	96.1%	0.6	23.4	3.5	C
	Right Turn	10	10	103.0%	0.1	21.3	6.6	C
	Subtotal	270	262	96.9%	0.5	23.3	3.5	C
SB	Left Turn	110	105	95.7%	0.5	13.7	1.7	B
	Through	90	88	98.0%	0.2	14.3	2.0	B
	Right Turn	10	10	100.0%	0.0	12.5	4.2	B
	Subtotal	210	204	96.9%	0.5	13.9	1.8	B
EB	Left Turn	10	7	74.0%	0.9	13.5	4.5	B
	Through	60	59	98.3%	0.1	13.2	1.7	B
	Right Turn	130	131	100.5%	0.1	10.7	1.2	B
	Subtotal	200	197	98.5%	0.2	11.5	1.2	B
WB	Left Turn	10	8	79.0%	0.7	43.1	20.4	E
	Through	260	255	98.1%	0.3	41.1	11.3	E
	Right Turn	120	118	98.6%	0.2	36.9	10.8	E
	Subtotal	390	381	97.8%	0.4	39.8	11.1	E
Total		1070	1044	97.5%	0.8	25.4	4.7	D

Intersection

Dubuque Way/Grand Avenue

Signalized

Direction	Movement	Volume (veh/hr)			GEH	Total Delay (sec/veh)		
		Demand	Served	% Served		Average	Std. Dev.	LOS
NB	Left Turn							
	Through							
	Right Turn							
	Subtotal							
SB	Left Turn	20	18	90.5%	0.4	38.4	4.0	D
	Through							
	Right Turn	50	49	98.6%	0.1	13.9	1.6	B
	Subtotal	70	67	96.3%	0.3	20.6	1.7	C
EB	Left Turn	30	26	85.0%	0.9	44.3	4.4	D
	Through	240	236	98.2%	0.3	5.1	0.9	A
	Right Turn							
	Subtotal	270	261	96.7%	0.5	8.9	0.8	A
WB	Left Turn							
	Through	1610	1595	99.0%	0.4	10.8	0.7	B
	Right Turn	70	72	102.3%	0.2	11.3	2.0	B
	Subtotal	1680	1666	99.2%	0.3	10.8	0.7	B
Total		2020	1995	98.8%	0.6	10.9	0.6	B

SimTraffic Post-Processor
Average Results from 20 Runs
Volume and Delay by Movement

Caltrain Electrification
2020 No Project Conditions
PM Peak Hour

Intersection

Linden Avenue-San Mateo Avenue/San Mateo Avenue

Signalized

Direction	Movement	Volume (veh/hr)			GEH	Total Delay (sec/veh)		
		Demand	Served	% Served		Average	Std. Dev.	LOS
NB	Left Turn							
	Through	150	144	96.2%	0.5	8.0	2.2	A
	Right Turn	270	275	102.0%	0.3	1.7	0.2	A
	Subtotal	420	420	99.9%	0.0	3.8	0.7	A
SB	Left Turn	160	156	97.8%	0.3	18.8	4.3	B
	Through	130	135	103.5%	0.4	3.7	0.6	A
	Right Turn							
	Subtotal	290	291	100.3%	0.1	11.8	2.5	B
EB	Left Turn							
	Through							
	Right Turn							
	Subtotal							
WB	Left Turn	220	220	100.1%	0.0	14.4	2.0	B
	Through							
	Right Turn	170	168	98.6%	0.2	7.5	1.9	A
	Subtotal	390	388	99.4%	0.1	11.4	2.0	B
Total		1100	1099	99.9%	0.0	8.6	1.5	A

Intersection

Herman Street/Scott Street

Unsignalized

Direction	Movement	Volume (veh/hr)			GEH	Total Delay (sec/veh)		
		Demand	Served	% Served		Average	Std. Dev.	LOS
NB	Left Turn	10	9	91.0%	0.3	10.2	3.5	B
	Through	110	113	102.5%	0.3	12.3	1.6	B
	Right Turn	120	115	95.8%	0.5	8.0	1.0	A
	Subtotal	240	237	98.7%	0.2	10.1	1.2	B
SB	Left Turn	50	47	94.6%	0.4	15.5	1.3	C
	Through	170	165	96.8%	0.4	15.2	1.1	C
	Right Turn	10	9	94.0%	0.2	11.3	3.6	B
	Subtotal	230	221	96.2%	0.6	15.1	1.1	C
EB	Left Turn	10	10	97.0%	0.1	6.6	1.8	A
	Through	20	21	105.0%	0.2	10.5	1.9	B
	Right Turn	10	11	114.0%	0.4	5.2	1.4	A
	Subtotal	40	42	105.3%	0.3	8.1	1.1	A
WB	Left Turn	180	179	99.2%	0.1	0.2	0.1	A
	Through	20	19	95.5%	0.2	0.2	0.1	A
	Right Turn	30	34	111.7%	0.6	0.1	0.1	A
	Subtotal	230	231	100.5%	0.1	0.2	0.0	A
Total		740	731	98.8%	0.3	8.3	0.5	A

Intersection **Montgomery Avenue/Scott Street**

Unsignalized

Direction	Movement	Volume (veh/hr)			GEH	Total Delay (sec/veh)		
		Demand	Served	% Served		Average	Std. Dev.	LOS
NB	Left Turn	30	30	101.0%	0.1	7.1	1.0	A
	Through	10	8	84.0%	0.5	8.2	2.0	A
	Right Turn	20	19	95.0%	0.2	3.9	0.6	A
	Subtotal	60	58	96.2%	0.3	6.2	0.8	A
SB	Left Turn	10	11	110.0%	0.3	6.5	0.6	A
	Through	10	10	98.0%	0.1	8.0	1.0	A
	Right Turn	20	21	105.5%	0.2	3.9	0.6	A
	Subtotal	40	42	104.8%	0.3	5.6	0.2	A
EB	Left Turn	20	17	86.0%	0.6	2.5	0.5	A
	Through	140	132	94.4%	0.7	0.7	0.1	A
	Right Turn	30	33	111.0%	0.6	0.3	0.3	A
	Subtotal	190	183	96.1%	0.5	0.8	0.1	A
WB	Left Turn	20	19	94.5%	0.2	2.1	0.5	A
	Through	180	177	98.2%	0.2	0.6	0.1	A
	Right Turn	10	10	97.0%	0.1	0.7	1.2	A
	Subtotal	210	205	97.8%	0.3	0.7	0.1	A
Total		500	488	97.5%	0.6	1.8	0.1	A

Intersection **Driveway-Dollar Avenue/Linden Avenue**

Signalized

Direction	Movement	Volume (veh/hr)			GEH	Total Delay (sec/veh)		
		Demand	Served	% Served		Average	Std. Dev.	LOS
NB	Left Turn	90	96	106.4%	0.6	66.2	8.7	E
	Through							
	Right Turn	50	53	105.2%	0.4	48.8	7.9	D
	Subtotal	140	148	106.0%	0.7	60.0	7.7	E
SB	Left Turn	10	9	94.0%	0.2	73.8	18.3	E
	Through							
	Right Turn							
	Subtotal	10	9	94.0%	0.2	73.8	18.3	E
EB	Left Turn							
	Through	230	227	98.7%	0.2	70.1	8.5	E
	Right Turn	130	121	92.9%	0.8	57.3	7.7	E
	Subtotal	360	348	96.6%	0.7	65.6	8.1	E
WB	Left Turn	50	48	95.8%	0.3	3.2	2.1	A
	Through	260	259	99.5%	0.1	4.1	0.7	A
	Right Turn	10	11	112.0%	0.4	0.5	0.4	A
	Subtotal	320	318	99.3%	0.1	3.8	0.6	A
Total		830	823	99.2%	0.2	40.9	3.8	D

SimTraffic Post-Processor
Average Results from 20 Runs
Volume and Delay by Movement

Caltrain Electrification
2020 No Project Conditions
PM Peak Hour

Intersection

San Mateo Avenue/San Bruno Avenue

Signalized

Direction	Movement	Volume (veh/hr)			GEH	Total Delay (sec/veh)		
		Demand	Served	% Served		Average	Std. Dev.	LOS
NB	Left Turn	30	29	95.0%	0.3	35.9	8.6	D
	Through	120	119	98.8%	0.1	30.1	4.8	C
	Right Turn	180	178	99.0%	0.1	10.6	1.0	B
	Subtotal	330	325	98.5%	0.3	19.9	2.8	B
SB	Left Turn	110	105	95.0%	0.5	46.0	4.8	D
	Through	100	102	102.2%	0.2	33.4	4.2	C
	Right Turn	140	135	96.7%	0.4	21.2	2.7	C
	Subtotal	350	342	97.7%	0.4	32.4	3.1	C
EB	Left Turn	10	9	91.0%	0.3	12.1	6.3	B
	Through	500	519	103.8%	0.8	7.2	0.7	A
	Right Turn	10	12	117.0%	0.5	3.3	3.0	A
	Subtotal	520	540	103.8%	0.9	7.2	0.7	A
WB	Left Turn	210	211	100.6%	0.1	44.9	3.1	D
	Through	550	561	102.0%	0.5	18.8	0.9	B
	Right Turn	60	60	100.5%	0.0	15.0	2.0	B
	Subtotal	820	833	101.5%	0.4	25.1	1.4	C
Total		2020	2039	101.0%	0.4	20.8	1.2	C

Intersection

El Camino Real/Millbrae Avenue

Signalized

Direction	Movement	Volume (veh/hr)			GEH	Total Delay (sec/veh)		
		Demand	Served	% Served		Average	Std. Dev.	LOS
NB	Left Turn	40	36	90.8%	0.6	79.0	5.6	E
	Through	860	848	98.6%	0.4	43.8	1.4	D
	Right Turn	410	417	101.8%	0.4	3.6	0.2	A
	Subtotal	1310	1301	99.3%	0.2	31.9	1.3	C
SB	Left Turn	650	593	91.2%	2.3	275.4	58.4	F
	Through	1100	1039	94.5%	1.9	117.0	43.2	F
	Right Turn	70	71	101.6%	0.1	117.5	40.0	F
	Subtotal	1820	1703	93.6%	2.8	172.3	49.0	F
EB	Left Turn	140	139	99.4%	0.1	249.8	127.1	F
	Through	380	387	101.7%	0.3	60.0	13.5	E
	Right Turn	80	81	101.8%	0.2	43.2	6.5	D
	Subtotal	600	607	101.2%	0.3	102.6	40.4	F
WB	Left Turn	600	577	96.1%	1.0	70.2	2.6	E
	Through	780	797	102.1%	0.6	48.9	1.6	D
	Right Turn	770	772	100.3%	0.1	19.1	1.2	B
	Subtotal	2150	2146	99.8%	0.1	43.9	1.0	D
Total		5880	5758	97.9%	1.6	85.1	15.9	F

Intersection

Rollins Road/Millbrae Avenue

Signalized

Direction	Movement	Volume (veh/hr)			GEH	Total Delay (sec/veh)		
		Demand	Served	% Served		Average	Std. Dev.	LOS
NB	Left Turn	370	370	100.0%	0.0	48.9	3.5	D
	Through	80	85	105.6%	0.5	45.7	5.7	D
	Right Turn	450	450	100.0%	0.0	30.1	6.9	C
	Subtotal	900	905	100.5%	0.2	39.3	4.8	D
SB	Left Turn	380	390	102.6%	0.5	35.1	1.2	D
	Through	130	129	99.2%	0.1	34.1	2.9	C
	Right Turn	210	207	98.4%	0.2	20.7	3.7	C
	Subtotal	720	726	100.8%	0.2	30.8	1.3	C
EB	Left Turn	140	130	92.6%	0.9	75.6	8.2	E
	Through	1160	1130	97.4%	0.9	38.8	1.1	D
	Right Turn	140	132	94.5%	0.7	17.3	2.0	B
	Subtotal	1440	1392	96.7%	1.3	40.2	1.3	D
WB	Left Turn	360	347	96.4%	0.7	109.7	53.4	F
	Through	1570	1562	99.5%	0.2	93.1	30.0	F
	Right Turn	230	227	98.6%	0.2	22.8	19.3	C
	Subtotal	2160	2136	98.9%	0.5	88.4	30.6	F
Total		5220	5159	98.8%	0.9	58.6	12.4	E

SimTraffic Post-Processor
Average Results from 20 Runs
Volume and Delay by Movement

Caltrain Electrification
2020 No Project Conditions
PM Peak Hour

Intersection

California Drive/Oak Grove

Signalized

Direction	Movement	Volume (veh/hr)			GEH	Total Delay (sec/veh)		
		Demand	Served	% Served		Average	Std. Dev.	LOS
NB	Left Turn	50	49	97.6%	0.2	52.9	7.3	D
	Through	580	595	102.7%	0.6	24.3	2.0	C
	Right Turn	250	242	96.9%	0.5	8.7	2.1	A
	Subtotal	880	886	100.7%	0.2	21.6	1.9	C
SB	Left Turn	50	52	104.8%	0.3	71.2	18.4	E
	Through	710	709	99.8%	0.0	26.6	2.4	C
	Right Turn	70	72	103.1%	0.3	11.5	0.9	B
	Subtotal	830	833	100.4%	0.1	28.0	1.8	C
EB	Left Turn	30	33	109.0%	0.5	39.1	2.5	D
	Through	240	238	99.1%	0.1	47.2	10.1	D
	Right Turn	40	38	95.0%	0.3	39.3	13.2	D
	Subtotal	310	309	99.5%	0.1	45.4	9.3	D
WB	Left Turn	200	146	72.8%	4.1	24.6	1.5	C
	Through	160	120	75.1%	3.4	23.6	1.4	C
	Right Turn	160	116	72.4%	3.8	13.5	1.8	B
	Subtotal	520	382	73.4%	6.5	20.9	0.9	C
Total		2540	2410	94.9%	2.6	26.8	1.8	C

Intersection

Carolan Ave/Oak Grove

Unsignalized

Direction	Movement	Volume (veh/hr)			GEH	Total Delay (sec/veh)		
		Demand	Served	% Served		Average	Std. Dev.	LOS
NB	Left Turn	50	45	89.0%	0.8	162.5	92.2	F
	Through	120	122	101.4%	0.2	130.6	84.8	F
	Right Turn	50	51	101.2%	0.1	135.6	91.9	F
	Subtotal	220	217	98.5%	0.2	138.4	87.7	F
SB	Left Turn	30	16	52.0%	3.0	203.2	19.5	F
	Through	160	92	57.7%	6.0	210.7	16.7	F
	Right Turn	310	184	59.2%	8.0	430.3	35.7	F
	Subtotal	500	292	58.3%	10.5	348.9	27.3	F
EB	Left Turn	340	336	98.7%	0.2	0.5	0.1	A
	Through	130	136	104.8%	0.5	1.0	0.2	A
	Right Turn	70	70	100.0%	0.0	0.1	0.1	A
	Subtotal	540	542	100.4%	0.1	0.6	0.1	A
WB	Left Turn	60	47	78.8%	1.7	283.6	65.7	F
	Through	160	140	87.2%	1.7	297.9	64.5	F
	Right Turn	20	17	84.5%	0.7	279.3	67.6	F
	Subtotal	240	204	84.9%	2.4	292.7	62.7	F
Total		1500	1254	83.6%	6.6	152.7	21.8	F

Intersection California Dr/North Lane

Unsignalized

Direction	Movement	Volume (veh/hr)			GEH	Total Delay (sec/veh)		
		Demand	Served	% Served		Average	Std. Dev.	LOS
NB	Left Turn							
	Through	670	679	101.3%	0.3	1.1	0.2	A
	Right Turn	70	70	100.6%	0.0	2.8	1.3	A
	Subtotal	740	749	101.2%	0.3	1.2	0.2	A
SB	Left Turn	140	134	96.0%	0.5	17.4	2.7	C
	Through	800	758	94.8%	1.5	5.9	0.9	A
	Right Turn							
	Subtotal	940	893	94.9%	1.6	7.6	0.9	A
EB	Left Turn							
	Through							
	Right Turn							
	Subtotal							
WB	Left Turn	40	36	89.0%	0.7	28.8	5.4	D
	Through							
	Right Turn	130	111	85.5%	1.7	5.6	0.4	A
	Subtotal	170	147	86.4%	1.8	11.2	1.3	B
Total		1850	1788	96.7%	1.4	5.2	0.6	A

Intersection Carolan Ave/North Lane

Unsignalized

Direction	Movement	Volume (veh/hr)			GEH	Total Delay (sec/veh)		
		Demand	Served	% Served		Average	Std. Dev.	LOS
NB	Left Turn	90	88	97.7%	0.2	20.1	3.4	C
	Through	130	124	95.5%	0.5	9.5	0.6	A
	Right Turn	10	10	104.0%	0.1	6.3	1.9	A
	Subtotal	230	222	96.7%	0.5	13.5	1.1	B
SB	Left Turn	10	6	64.0%	1.3	11.8	5.8	B
	Through	180	142	78.6%	3.0	14.0	3.8	B
	Right Turn	80	58	72.3%	2.7	12.4	3.9	B
	Subtotal	270	206	76.2%	4.2	13.5	3.0	B
EB	Left Turn	70	70	100.1%	0.0	0.8	0.3	A
	Through	10	15	146.0%	1.3	0.8	0.4	A
	Right Turn	130	126	96.8%	0.4	0.6	0.2	A
	Subtotal	210	211	100.2%	0.0	0.7	0.2	A
WB	Left Turn							
	Through							
	Right Turn							
	Subtotal							
Total		710	639	89.9%	2.7	9.3	1.4	A

Intersection Anita Road/Peninsula Avenue

Unsignalized

Direction	Movement	Volume (veh/hr)			GEH	Total Delay (sec/veh)		
		Demand	Served	% Served		Average	Std. Dev.	LOS
NB	Left Turn							
	Through							
	Right Turn							
	Subtotal							
SB	Left Turn	20	20	100.5%	0.0	43.8	19.2	E
	Through							
	Right Turn	20	20	100.0%	0.0	62.1	32.2	F
	Subtotal	40	40	100.3%	0.0	53.3	22.8	F
EB	Left Turn	20	20	101.0%	0.0	18.0	5.0	C
	Through	640	637	99.5%	0.1	1.1	0.5	A
	Right Turn							
	Subtotal	660	657	99.6%	0.1	1.6	0.7	A
WB	Left Turn							
	Through	650	651	100.2%	0.1	17.3	4.7	C
	Right Turn	60	59	98.3%	0.1	13.5	5.9	B
	Subtotal	710	710	100.1%	0.0	17.0	4.7	C
Total		1410	1408	99.8%	0.1	10.9	3.1	B

Intersection Woodside Way/Villa Terrace

Unsignalized

Direction	Movement	Volume (veh/hr)			GEH	Total Delay (sec/veh)		
		Demand	Served	% Served		Average	Std. Dev.	LOS
NB	Left Turn	10	10	101.0%	0.0	4.9	1.3	A
	Through	20	22	108.5%	0.4	5.9	0.4	A
	Right Turn	10	11	110.0%	0.3	2.8	0.4	A
	Subtotal	40	43	107.0%	0.4	4.9	0.6	A
SB	Left Turn	20	17	86.5%	0.6	5.6	0.7	A
	Through	50	47	94.4%	0.4	7.1	0.4	A
	Right Turn	60	57	94.3%	0.4	4.0	0.7	A
	Subtotal	130	121	93.2%	0.8	5.5	0.4	A
EB	Left Turn	30	29	96.0%	0.2	2.8	0.2	A
	Through	30	29	98.0%	0.1	2.5	0.2	A
	Right Turn	20	21	105.5%	0.2	1.3	0.2	A
	Subtotal	80	79	99.1%	0.1	2.3	0.2	A
WB	Left Turn	10	8	80.0%	0.7	2.2	0.5	A
	Through	30	31	103.7%	0.2	0.6	0.3	A
	Right Turn	20	20	100.0%	0.0	0.2	0.1	A
	Subtotal	60	59	98.5%	0.1	0.7	0.2	A
Total		310	302	97.5%	0.4	3.6	0.2	A

Intersection **N. San Mateo Drive/Villa Terrace**

Unsignalized

Direction	Movement	Volume (veh/hr)			GEH	Total Delay (sec/veh)		
		Demand	Served	% Served		Average	Std. Dev.	LOS
NB	Left Turn	10	9	91.0%	0.3	4.5	1.7	A
	Through	590	592	100.3%	0.1	0.7	0.1	A
	Right Turn	50	50	100.8%	0.1	0.8	0.2	A
	Subtotal	650	651	100.2%	0.0	0.7	0.1	A
SB	Left Turn	20	19	95.0%	0.2	6.5	1.6	A
	Through	510	498	97.7%	0.5	2.9	0.3	A
	Right Turn	20	22	107.5%	0.3	3.2	0.9	A
	Subtotal	550	539	97.9%	0.5	3.0	0.4	A
EB	Left Turn	10	9	93.0%	0.2	10.9	4.6	B
	Through	10	9	91.0%	0.3	15.2	4.6	C
	Right Turn	20	18	91.5%	0.4	5.4	1.4	A
	Subtotal	40	37	91.8%	0.5	9.4	2.0	A
WB	Left Turn	40	33	81.8%	1.2	18.4	2.7	C
	Through	20	23	115.0%	0.6	19.3	4.1	C
	Right Turn	40	42	105.0%	0.3	11.7	2.4	B
	Subtotal	100	98	97.7%	0.2	15.8	2.8	C
Total		1340	1324	98.8%	0.4	3.0	0.4	A

Intersection **Arundel Road/Peninsula Avenue**

Unsignalized

Direction	Movement	Volume (veh/hr)			GEH	Total Delay (sec/veh)		
		Demand	Served	% Served		Average	Std. Dev.	LOS
NB	Left Turn	20	22	107.5%	0.3	41.5	9.1	E
	Through	10	11	113.0%	0.4	28.3	11.8	D
	Right Turn	40	38	95.3%	0.3	17.2	6.2	C
	Subtotal	70	71	101.3%	0.1	26.1	7.0	D
SB	Left Turn	20	20	100.0%	0.0	48.9	29.0	E
	Through	10	11	107.0%	0.2	57.0	33.4	F
	Right Turn	20	22	108.5%	0.4	57.0	47.4	F
	Subtotal	50	52	104.8%	0.3	54.5	37.0	F
EB	Left Turn	10	8	78.0%	0.7	7.5	4.7	A
	Through	590	591	100.1%	0.0	1.1	0.1	A
	Right Turn	60	58	96.7%	0.3	1.0	0.2	A
	Subtotal	660	657	99.5%	0.1	1.1	0.1	A
WB	Left Turn	60	53	88.0%	1.0	19.5	11.0	C
	Through	670	667	99.5%	0.1	16.5	11.1	C
	Right Turn	30	26	87.7%	0.7	15.4	12.9	C
	Subtotal	760	746	98.1%	0.5	16.7	11.1	C
Total		1540	1526	99.1%	0.4	11.8	6.6	B

Intersection **Railroad Ave/1st Ave**

Unsignalized

Direction	Movement	Volume (veh/hr)			GEH	Total Delay (sec/veh)		
		Demand	Served	% Served		Average	Std. Dev.	LOS
NB	Left Turn	20	20	98.5%	0.1	24.8	8.8	C
	Through	20	23	114.0%	0.6	16.0	4.0	C
	Right Turn	10	11	111.0%	0.3	8.7	3.5	A
	Subtotal	50	54	107.2%	0.5	17.8	5.0	C
SB	Left Turn							
	Through							
	Right Turn							
	Subtotal							
EB	Left Turn	10	8	80.0%	0.7	2.5	1.0	A
	Through	250	254	101.4%	0.2	0.4	0.1	A
	Right Turn							
	Subtotal	260	262	100.6%	0.1	0.5	0.1	A
WB	Left Turn							
	Through	210	214	102.0%	0.3	9.7	3.8	A
	Right Turn	10	12	119.0%	0.6	5.9	3.0	A
	Subtotal	220	226	102.7%	0.4	9.5	3.7	A
Total		530	541	102.1%	0.5	6.0	1.9	A

Intersection **S. B. St/1st Ave**

Signalized

Direction	Movement	Volume (veh/hr)			GEH	Total Delay (sec/veh)		
		Demand	Served	% Served		Average	Std. Dev.	LOS
NB	Left Turn	60	54	90.2%	0.8	73.1	7.8	E
	Through	390	374	95.9%	0.8	72.7	10.5	E
	Right Turn	70	66	94.4%	0.5	68.5	18.1	E
	Subtotal	520	494	95.0%	1.1	71.9	8.8	E
SB	Left Turn	60	59	98.2%	0.1	66.8	7.2	E
	Through	170	173	101.5%	0.2	50.1	6.0	D
	Right Turn	40	39	97.5%	0.2	44.1	6.3	D
	Subtotal	270	270	100.1%	0.0	52.9	5.6	D
EB	Left Turn	20	19	94.0%	0.3	29.9	6.4	C
	Through	130	138	105.8%	0.7	21.7	4.5	C
	Right Turn	40	40	101.0%	0.1	15.0	4.5	B
	Subtotal	190	197	103.6%	0.5	21.1	4.0	C
WB	Left Turn	50	48	95.4%	0.3	19.0	2.8	B
	Through	100	116	115.8%	1.5	13.2	2.0	B
	Right Turn	80	79	98.3%	0.2	11.3	1.7	B
	Subtotal	230	242	105.3%	0.8	13.7	1.3	B
Total		1210	1204	99.5%	0.2	47.6	4.1	D

SimTraffic Post-Processor
Average Results from 20 Runs
Volume and Delay by Movement

Caltrain Electrification
2020 No Project Conditions
PM Peak Hour

Intersection

Transit Center Way/1st St

Unsignalized

Direction	Movement	Volume (veh/hr)			GEH	Total Delay (sec/veh)		
		Demand	Served	% Served		Average	Std. Dev.	LOS
NB	Left Turn	50	53	106.8%	0.5	14.0	4.2	B
	Through	10	10	95.0%	0.2	14.0	7.1	B
	Right Turn	50	49	98.2%	0.1	10.6	3.3	B
	Subtotal	110	112	101.8%	0.2	12.5	3.1	B
SB	Left Turn							
	Through							
	Right Turn							
	Subtotal							
EB	Left Turn	40	41	101.8%	0.1	5.2	1.1	A
	Through	210	221	105.0%	0.7	3.1	0.7	A
	Right Turn	10	10	99.0%	0.0	1.9	1.6	A
	Subtotal	260	271	104.3%	0.7	3.3	0.7	A
WB	Left Turn							
	Through	180	187	103.9%	0.5	3.7	1.2	A
	Right Turn	50	54	107.8%	0.5	1.4	0.8	A
	Subtotal	230	241	104.8%	0.7	3.2	1.1	A
Total		600	624	104.0%	1.0	4.9	0.9	A

Intersection **Railroad Avenue/9th Avenue**

Unsignalized

Direction	Movement	Volume (veh/hr)			GEH	Total Delay (sec/veh)		
		Demand	Served	% Served		Average	Std. Dev.	LOS
NB	Left Turn	40	37	91.5%	0.5	56.1	23.5	F
	Through							
	Right Turn	50	53	106.6%	0.5	32.4	15.7	D
	Subtotal	90	90	99.9%	0.0	41.8	16.9	E
SB	Left Turn							
	Through							
	Right Turn							
	Subtotal							
EB	Left Turn							
	Through	490	477	97.3%	0.6	0.9	0.1	A
	Right Turn	60	58	96.8%	0.2	0.1	0.1	A
	Subtotal	550	535	97.3%	0.6	0.8	0.1	A
WB	Left Turn	10	10	99.0%	0.0	13.6	5.6	B
	Through	480	487	101.4%	0.3	6.6	1.4	A
	Right Turn							
	Subtotal	490	497	101.3%	0.3	6.7	1.4	A
Total		1130	1121	99.2%	0.3	6.7	1.9	A

Intersection **S B Street/9th Avenue**

Signalized

Direction	Movement	Volume (veh/hr)			GEH	Total Delay (sec/veh)		
		Demand	Served	% Served		Average	Std. Dev.	LOS
NB	Left Turn	10	9	92.0%	0.3	21.1	4.7	C
	Through	130	119	91.7%	1.0	16.3	1.8	B
	Right Turn	140	131	93.3%	0.8	9.7	1.1	A
	Subtotal	280	259	92.5%	1.3	13.1	1.0	B
SB	Left Turn	90	88	98.0%	0.2	26.2	4.5	C
	Through	190	189	99.6%	0.1	13.9	2.0	B
	Right Turn	60	56	93.8%	0.5	8.0	2.0	A
	Subtotal	340	334	98.2%	0.3	16.2	2.5	B
EB	Left Turn	60	57	94.2%	0.5	47.7	8.7	D
	Through	320	315	98.4%	0.3	45.8	9.4	D
	Right Turn	20	22	109.0%	0.4	37.8	14.8	D
	Subtotal	400	393	98.3%	0.3	45.5	9.1	D
WB	Left Turn	90	90	100.2%	0.0	19.7	3.2	B
	Through	320	316	98.8%	0.2	11.1	1.1	B
	Right Turn	110	111	100.5%	0.1	7.0	1.5	A
	Subtotal	520	517	99.4%	0.1	11.7	1.1	B
Total		1540	1503	97.6%	0.9	21.8	2.8	C

Intersection

Concar Drive/SR 92 WB Ramps

Signalized

Direction	Movement	Volume (veh/hr)			GEH	Total Delay (sec/veh)		
		Demand	Served	% Served		Average	Std. Dev.	LOS
NB	Left Turn	110	108	98.3%	0.2	19.2	1.2	B
	Through	50	55	109.8%	0.7	15.8	1.4	B
	Right Turn							
	Subtotal	160	163	101.9%	0.2	18.0	0.9	B
SB	Left Turn	30	28	92.3%	0.4	18.1	2.8	B
	Through	50	54	107.2%	0.5	16.0	1.7	B
	Right Turn	10	9	89.0%	0.4	4.2	2.2	A
	Subtotal	90	90	100.2%	0.0	15.5	1.6	B
EB	Left Turn	10	10	99.0%	0.0	23.0	7.3	C
	Through	70	73	103.6%	0.3	27.4	2.0	C
	Right Turn	60	57	94.3%	0.4	13.9	2.5	B
	Subtotal	140	139	99.3%	0.1	21.7	2.4	C
WB	Left Turn	710	697	98.1%	0.5	4.8	0.5	A
	Through	90	85	94.6%	0.5	6.2	0.8	A
	Right Turn	50	51	101.2%	0.1	1.4	0.5	A
	Subtotal	850	832	97.9%	0.6	4.7	0.5	A
Total		1240	1225	98.8%	0.4	9.2	0.5	A

SimTraffic Post-Processor
Average Results from 20 Runs
Volume and Delay by Movement

Caltrain Electrification
2020 No Project Conditions
PM Peak Hour

Intersection

Delaware Ave/25th Ave

Signalized

Direction	Movement	Volume (veh/hr)			GEH	Total Delay (sec/veh)		
		Demand	Served	% Served		Average	Std. Dev.	LOS
NB	Left Turn	60	42	69.7%	2.6	586.6	324.5	F
	Through	10	12	118.0%	0.5	18.8	6.6	B
	Right Turn							
	Subtotal	70	54	76.6%	2.1	463.0	256.1	F
SB	Left Turn							
	Through	10	10	104.0%	0.1	37.1	30.9	D
	Right Turn	700	663	94.8%	1.4	98.7	60.1	F
	Subtotal	710	674	94.9%	1.4	97.8	59.6	F
EB	Left Turn	620	595	96.0%	1.0	8.0	0.8	A
	Through							
	Right Turn	40	39	97.5%	0.2	3.8	0.9	A
	Subtotal	660	634	96.1%	1.0	7.7	0.8	A
WB	Left Turn							
	Through							
	Right Turn							
	Subtotal							
Total		1440	1362	94.6%	2.1	69.5	35.8	E

Intersection

El Camino Real/25th Ave

Signalized

Direction	Movement	Volume (veh/hr)			GEH	Total Delay (sec/veh)		
		Demand	Served	% Served		Average	Std. Dev.	LOS
NB	Left Turn	110	112	101.5%	0.2	100.0	10.6	F
	Through	1790	1741	97.3%	1.2	85.5	9.8	F
	Right Turn	320	311	97.2%	0.5	100.0	11.9	F
	Subtotal	2220	2164	97.5%	1.2	88.3	9.9	F
SB	Left Turn	200	193	96.7%	0.5	245.8	87.1	F
	Through	1310	1324	101.0%	0.4	36.9	4.3	D
	Right Turn	120	120	100.3%	0.0	38.6	5.8	D
	Subtotal	1630	1637	100.4%	0.2	61.7	13.6	E
EB	Left Turn	220	202	91.8%	1.2	244.1	53.0	F
	Through	140	131	93.9%	0.7	278.2	51.1	F
	Right Turn	80	73	91.8%	0.8	200.1	48.8	F
	Subtotal	440	407	92.5%	1.6	247.1	50.5	F
WB	Left Turn	520	458	88.1%	2.8	77.5	3.0	E
	Through	190	177	93.4%	0.9	86.9	4.0	F
	Right Turn	120	113	94.5%	0.6	46.8	3.8	D
	Subtotal	830	749	90.2%	2.9	75.1	2.6	E
Total		5120	4957	96.8%	2.3	90.6	7.1	F

Intersection El Camino Real/31st Street

Signalized

Direction	Movement	Volume (veh/hr)			GEH	Total Delay (sec/veh)		
		Demand	Served	% Served		Average	Std. Dev.	LOS
NB	Left Turn	150	144	96.0%	0.5	59.6	12.9	E
	Through	1720	1672	97.2%	1.2	32.3	1.1	C
	Right Turn	100	100	100.2%	0.0	3.2	0.6	A
	Subtotal	1970	1917	97.3%	1.2	32.9	1.1	C
SB	Left Turn	280	281	100.2%	0.0	79.8	19.2	E
	Through	1710	1725	100.9%	0.4	37.3	6.5	D
	Right Turn	70	73	104.3%	0.4	20.1	2.7	C
	Subtotal	2060	2079	100.9%	0.4	42.6	7.4	D
EB	Left Turn	260	251	96.7%	0.5	56.5	12.0	E
	Through	30	30	99.0%	0.1	69.7	16.7	E
	Right Turn	160	161	100.4%	0.0	10.3	1.8	B
	Subtotal	450	442	98.2%	0.4	40.7	8.2	D
WB	Left Turn	90	84	93.3%	0.6	28.9	3.4	C
	Through	30	33	108.3%	0.4	29.5	1.8	C
	Right Turn	20	19	94.0%	0.3	14.7	2.6	B
	Subtotal	140	135	96.6%	0.4	27.1	2.0	C
Total		4620	4572	99.0%	0.7	37.9	4.1	D

Intersection El Camino Real/Hillsdale Blvd

Signalized

Direction	Movement	Volume (veh/hr)			GEH	Total Delay (sec/veh)		
		Demand	Served	% Served		Average	Std. Dev.	LOS
NB	Left Turn							
	Through							
	Right Turn							
	Subtotal							
SB	Left Turn	560	568	101.5%	0.3	47.2	6.7	D
	Through							
	Right Turn	180	179	99.6%	0.1	25.0	17.8	C
	Subtotal	740	747	101.0%	0.3	41.8	9.1	D
EB	Left Turn							
	Through	560	474	84.7%	3.8	96.9	5.4	F
	Right Turn	170	151	88.9%	1.5	51.5	7.7	D
	Subtotal	730	626	85.7%	4.0	85.9	6.0	F
WB	Left Turn	330	311	94.2%	1.1	5.9	4.1	A
	Through	720	678	94.2%	1.6	4.8	2.2	A
	Right Turn							
	Subtotal	1050	989	94.2%	1.9	5.1	2.4	A
Total		3300	3121	94.6%	3.2	49.9	5.0	D

SimTraffic Post-Processor
Average Results from 20 Runs
Volume and Delay by Movement

Caltrain Electrification
2020 No Project Conditions
PM Peak Hour

Intersection **Curtiss Street/Hillsdale Blvd**

Signalized

Direction	Movement	Volume (veh/hr)			GEH	Total Delay (sec/veh)		
		Demand	Served	% Served		Average	Std. Dev.	LOS
NB	Left Turn	50	47	93.8%	0.4	49.5	6.5	D
	Through	30	31	102.3%	0.1	45.5	12.6	D
	Right Turn	60	59	97.5%	0.2	20.7	7.7	C
	Subtotal	140	136	97.2%	0.3	36.2	8.0	D
SB	Left Turn	40	38	95.8%	0.3	48.3	6.9	D
	Through	10	9	93.0%	0.2	43.7	5.9	D
	Right Turn	10	9	89.0%	0.4	29.5	9.6	C
	Subtotal	60	57	94.2%	0.5	43.9	4.2	D
EB	Left Turn	10	8	84.0%	0.5	16.3	4.1	B
	Through	1290	1233	95.6%	1.6	4.6	0.7	A
	Right Turn	70	62	88.9%	1.0	4.4	1.1	A
	Subtotal	1370	1303	95.1%	1.8	4.6	0.7	A
WB	Left Turn	10	10	102.0%	0.1	28.6	18.4	C
	Through	1310	1274	97.2%	1.0	12.7	7.2	B
	Right Turn	40	44	109.0%	0.6	12.7	7.7	B
	Subtotal	1360	1327	97.6%	0.9	12.8	7.3	B
Total		2930	2823	96.4%	2.0	10.8	3.5	B

SimTraffic Post-Processor
Average Results from 20 Runs
Volume and Delay by Movement

Caltrain Electrification
2020 No Project Conditions
PM Peak Hour

Intersection

El Camino Real/Ralston Avenue

Signalized

Direction	Movement	Volume (veh/hr)			GEH	Total Delay (sec/veh)		
		Demand	Served	% Served		Average	Std. Dev.	LOS
NB	Left Turn	210	183	87.2%	1.9	218.7	12.9	F
	Through	950	824	86.7%	4.2	205.3	8.8	F
	Right Turn	230	198	86.2%	2.2	29.5	4.2	C
	Subtotal	1390	1205	86.7%	5.1	178.4	7.8	F
SB	Left Turn	340	296	87.2%	2.4	241.0	29.1	F
	Through	1100	1002	91.1%	3.0	98.7	12.6	F
	Right Turn	140	129	91.9%	1.0	58.4	13.8	E
	Subtotal	1580	1427	90.3%	3.9	124.9	7.9	F
EB	Left Turn	280	269	95.9%	0.7	195.0	29.2	F
	Through	620	567	91.4%	2.2	224.6	34.3	F
	Right Turn	80	75	94.0%	0.5	251.2	48.1	F
	Subtotal	980	911	92.9%	2.3	218.1	33.8	F
WB	Left Turn	260	255	98.0%	0.3	47.9	4.5	D
	Through	670	671	100.2%	0.0	100.5	29.7	F
	Right Turn	450	438	97.4%	0.6	86.6	41.0	F
	Subtotal	1380	1364	98.9%	0.4	86.4	17.0	F
Total		5330	4907	92.1%	5.9	144.5	7.2	F

SimTraffic Post-Processor
Average Results from 20 Runs
Volume and Delay by Movement

Caltrain Electrification
2020 No Project Conditions
PM Peak Hour

Intersection

El Camino Real/San Carlos Avenue-Caltrain Station

Signalized

Direction	Movement	Volume (veh/hr)			GEH	Total Delay (sec/veh)		
		Demand	Served	% Served		Average	Std. Dev.	LOS
NB	Left Turn	250	221	88.4%	1.9	364.5	120.2	F
	Through	1060	1021	96.3%	1.2	48.0	26.3	D
	Right Turn	20	19	97.0%	0.1	40.3	24.4	D
	Subtotal	1330	1262	94.8%	1.9	103.5	41.9	F
SB	Left Turn	30	27	89.7%	0.6	70.4	24.1	E
	Through	940	930	99.0%	0.3	66.5	10.4	E
	Right Turn	410	406	99.1%	0.2	41.3	8.9	D
	Subtotal	1380	1363	98.8%	0.4	59.0	10.2	E
EB	Left Turn	390	390	100.1%	0.0	22.4	1.2	C
	Through	70	75	107.0%	0.6	24.6	2.5	C
	Right Turn	190	198	103.9%	0.5	20.0	1.7	B
	Subtotal	650	663	102.0%	0.5	22.0	1.2	C
WB	Left Turn	10	11	105.0%	0.2	52.3	8.0	D
	Through	20	20	101.5%	0.1	43.9	3.6	D
	Right Turn	30	29	96.7%	0.2	16.1	1.6	B
	Subtotal	60	60	99.7%	0.0	31.7	3.3	C
Total		3420	3347	97.9%	1.2	67.9	15.3	E

Intersection **California/Broadway**

Unsignalized

Direction	Movement	Volume (veh/hr)			GEH	Total Delay (sec/veh)		
		Demand	Served	% Served		Average	Std. Dev.	LOS
NB	Left Turn	20	17	84.0%	0.7	425.6	80.4	F
	Through	40	36	91.0%	0.6	371.8	75.3	F
	Right Turn	70	59	84.7%	1.3	389.6	84.1	F
	Subtotal	130	113	86.5%	1.6	389.5	77.8	F
SB	Left Turn	30	21	68.3%	1.9	730.5	251.0	F
	Through	60	44	74.0%	2.2	728.9	235.0	F
	Right Turn	70	55	77.9%	2.0	726.3	284.0	F
	Subtotal	160	119	74.6%	3.4	727.5	255.6	F
EB	Left Turn	40	17	41.8%	4.4	168.1	37.8	F
	Through	530	241	45.5%	14.7	180.8	16.9	F
	Right Turn	90	43	47.2%	5.8	173.7	33.5	F
	Subtotal	660	300	45.5%	16.4	178.9	19.1	F
WB	Left Turn	160	91	56.6%	6.2	8.0	1.2	A
	Through	660	388	58.7%	11.9	3.4	0.3	A
	Right Turn	50	31	61.0%	3.1	0.3	0.2	A
	Subtotal	870	509	58.5%	13.8	4.0	0.4	A
Total		1820	1041	57.2%	20.6	178.0	28.6	F

Intersection **Arguello Street/Brewster Ave**

Signalized

Direction	Movement	Volume (veh/hr)			GEH	Total Delay (sec/veh)		
		Demand	Served	% Served		Average	Std. Dev.	LOS
NB	Left Turn	100	66	65.7%	3.8	87.1	15.7	F
	Through	250	163	65.2%	6.0	62.9	13.7	E
	Right Turn	70	48	67.9%	2.9	23.1	12.7	C
	Subtotal	420	276	65.8%	7.7	61.8	13.9	E
SB	Left Turn	30	22	73.3%	1.6	712.6	248.5	F
	Through	150	126	83.7%	2.1	704.0	254.9	F
	Right Turn	130	108	83.4%	2.0	681.4	237.1	F
	Subtotal	310	256	82.6%	3.2	694.5	245.0	F
EB	Left Turn	110	102	92.6%	0.8	14.7	1.5	B
	Through	180	174	96.7%	0.5	13.3	2.5	B
	Right Turn	60	60	100.3%	0.0	3.6	2.9	A
	Subtotal	350	336	96.0%	0.8	12.0	1.6	B
WB	Left Turn	50	50	100.4%	0.0	60.3	9.3	E
	Through	400	397	99.3%	0.2	56.4	5.8	E
	Right Turn	50	52	104.4%	0.3	45.1	8.6	D
	Subtotal	500	499	99.9%	0.0	55.6	6.3	E
Total		1580	1368	86.6%	5.5	164.3	43.1	F

Intersection **El Camino Real/Broadway**

Signalized

Direction	Movement	Volume (veh/hr)			GEH	Total Delay (sec/veh)		
		Demand	Served	% Served		Average	Std. Dev.	LOS
NB	Left Turn	210	190	90.6%	1.4	174.8	63.2	F
	Through	1250	1177	94.2%	2.1	69.2	6.2	E
	Right Turn	100	99	99.1%	0.1	129.8	28.3	F
	Subtotal	1560	1467	94.0%	2.4	87.2	11.1	F
SB	Left Turn	230	91	39.7%	10.9	584.7	76.9	F
	Through	1270	602	47.4%	21.8	28.7	2.5	C
	Right Turn	20	9	42.5%	3.0	13.5	5.2	B
	Subtotal	1520	702	46.2%	24.5	100.6	10.8	F
EB	Left Turn	20	7	32.5%	3.7	459.3	101.7	F
	Through	330	109	33.0%	14.9	539.0	31.9	F
	Right Turn	220	73	33.1%	12.2	430.0	22.6	F
	Subtotal	570	188	33.0%	19.6	494.8	28.8	F
WB	Left Turn	110	61	55.7%	5.3	37.5	2.4	D
	Through	390	247	63.3%	8.0	34.2	3.2	C
	Right Turn	250	153	61.4%	6.8	29.9	3.6	C
	Subtotal	750	462	61.6%	11.7	33.2	2.6	C
Total		4400	2819	64.1%	26.3	108.7	6.1	F

Intersection **Arguello St/Broadway**

Signalized

Direction	Movement	Volume (veh/hr)			GEH	Total Delay (sec/veh)		
		Demand	Served	% Served		Average	Std. Dev.	LOS
NB	Left Turn	50	49	98.2%	0.1	90.4	19.2	F
	Through	140	134	95.9%	0.5	75.5	13.3	E
	Right Turn	220	222	101.0%	0.1	69.2	16.1	E
	Subtotal	410	406	98.9%	0.2	73.8	15.2	E
SB	Left Turn	30	24	80.0%	1.2	222.0	58.8	F
	Through	160	142	88.8%	1.5	213.0	45.9	F
	Right Turn	70	67	95.6%	0.4	192.3	49.7	F
	Subtotal	260	233	89.6%	1.7	207.7	47.1	F
EB	Left Turn	180	89	49.4%	7.8	14.0	1.8	B
	Through	300	158	52.6%	9.4	7.2	1.0	A
	Right Turn	150	76	50.5%	7.0	0.9	0.2	A
	Subtotal	630	323	51.2%	14.1	7.6	0.8	A
WB	Left Turn	20	11	53.5%	2.4	159.9	24.4	F
	Through	750	393	52.5%	14.9	126.7	6.3	F
	Right Turn	100	49	49.4%	5.9	67.4	9.9	E
	Subtotal	870	454	52.1%	16.2	121.1	6.6	F
Total		2170	1415	65.2%	17.8	95.7	8.5	F

SimTraffic Post-Processor
Average Results from 20 Runs
Volume and Delay by Movement

Caltrain Electrification
2020 No Project Conditions
PM Peak Hour

Intersection

El Camino Real/James

Signalized

Direction	Movement	Volume (veh/hr)			GEH	Total Delay (sec/veh)		
		Demand	Served	% Served		Average	Std. Dev.	LOS
NB	Left Turn	137	125	91.3%	1.0	162.7	96.7	F
	Through	1463	1323	90.4%	3.8	129.5	98.0	F
	Right Turn	42	35	83.3%	1.1	94.7	93.0	F
	Subtotal	1642	1483	90.3%	4.0	131.5	97.6	F
SB	Left Turn	126	50	39.9%	8.1	44.3	9.6	D
	Through	1474	657	44.6%	25.0	14.8	1.3	B
	Right Turn	84	39	45.8%	5.8	5.4	0.7	A
	Subtotal	1684	746	44.3%	26.9	16.3	1.2	B
EB	Left Turn	95	88	92.9%	0.7	38.7	3.1	D
	Through	200	187	93.7%	0.9	27.5	4.1	C
	Right Turn	105	106	100.8%	0.1	13.8	1.6	B
	Subtotal	400	381	95.4%	0.9	26.2	2.7	C
WB	Left Turn	126	74	58.9%	5.2	35.3	2.3	D
	Through	116	68	58.8%	5.0	24.0	3.9	C
	Right Turn	84	47	55.8%	4.6	21.9	3.9	C
	Subtotal	326	189	58.1%	8.5	28.0	1.9	C
Total		4052	2799	69.1%	21.4	79.2	52.1	E

Intersection

El Camino Real/Atherton Avenue-Fair Oaks Lane

Signalized

Direction	Movement	Volume (veh/hr)			GEH	Total Delay (sec/veh)		
		Demand	Served	% Served		Average	Std. Dev.	LOS
NB	Left Turn	220	209	94.8%	0.8	99.0	23.6	F
	Through	1820	1820	100.0%	0.0	22.2	2.1	C
	Right Turn	80	81	101.3%	0.1	27.0	3.0	C
	Subtotal	2120	2110	99.5%	0.2	30.0	3.7	C
SB	Left Turn	40	40	99.5%	0.0	45.8	4.2	D
	Through	1280	1295	101.2%	0.4	27.4	1.7	C
	Right Turn	80	79	98.5%	0.1	30.2	3.2	C
	Subtotal	1400	1414	101.0%	0.4	28.1	1.7	C
EB	Left Turn	130	130	99.6%	0.0	37.4	2.2	D
	Through	90	88	97.2%	0.3	31.8	3.0	C
	Right Turn	70	74	105.9%	0.5	17.5	2.7	B
	Subtotal	290	291	100.4%	0.1	30.7	2.2	C
WB	Left Turn	40	37	91.8%	0.5	56.8	14.1	E
	Through	110	104	94.6%	0.6	55.4	10.8	E
	Right Turn	70	70	100.1%	0.0	22.8	7.0	C
	Subtotal	220	211	95.9%	0.6	44.9	9.6	D
Total		4030	4026	99.9%	0.1	30.2	2.3	C

Intersection

El Camino Real/Watkins Avenue

Unsignalized

Direction	Movement	Volume (veh/hr)			GEH	Total Delay (sec/veh)		
		Demand	Served	% Served		Average	Std. Dev.	LOS
NB	Left Turn							
	Through	2020	2036	100.8%	0.3	2.3	0.1	A
	Right Turn	50	50	99.6%	0.0	3.1	0.5	A
	Subtotal	2070	2085	100.7%	0.3	2.3	0.1	A
SB	Left Turn	40	37	91.3%	0.6	30.6	4.1	D
	Through	1350	1372	101.6%	0.6	4.3	0.2	A
	Right Turn							
	Subtotal	1390	1409	101.3%	0.5	5.0	0.2	A
EB	Left Turn							
	Through							
	Right Turn							
	Subtotal							
WB	Left Turn	30	20	67.7%	1.9	827.9	301.3	F
	Through							
	Right Turn	100	72	71.7%	3.1	764.6	249.4	F
	Subtotal	130	92	70.8%	3.6	777.6	255.1	F
Total		3590	3586	99.9%	0.1	22.7	5.7	C

Intersection **El Camino Real/Glenwood**

Signalized

Direction	Movement	Volume (veh/hr)			GEH	Total Delay (sec/veh)		
		Demand	Served	% Served		Average	Std. Dev.	LOS
NB	Left Turn	150	137	91.6%	1.1	61.8	6.7	E
	Through	1650	1453	88.0%	5.0	31.2	2.1	C
	Right Turn	50	50	99.6%	0.0	23.4	3.9	C
	Subtotal	1850	1640	88.6%	5.0	33.5	2.2	C
SB	Left Turn	60	56	93.7%	0.5	88.1	28.6	F
	Through	1030	1010	98.1%	0.6	48.6	31.5	D
	Right Turn	260	264	101.5%	0.2	18.1	19.0	B
	Subtotal	1350	1330	98.5%	0.5	44.3	28.9	D
EB	Left Turn	320	312	97.6%	0.4	262.6	118.4	F
	Through	120	116	96.8%	0.3	261.9	111.8	F
	Right Turn	110	105	95.5%	0.5	215.8	126.8	F
	Subtotal	550	534	97.0%	0.7	253.1	118.6	F
WB	Left Turn	90	86	95.7%	0.4	80.5	14.6	F
	Through	170	169	99.4%	0.1	88.6	18.9	F
	Right Turn	30	32	106.3%	0.3	78.7	16.2	E
	Subtotal	290	287	99.0%	0.2	85.1	16.9	F
Total		4040	3791	93.8%	4.0	72.1	16.9	E

Intersection **El Camino Real/Oak Grove**

Signalized

Direction	Movement	Volume (veh/hr)			GEH	Total Delay (sec/veh)		
		Demand	Served	% Served		Average	Std. Dev.	LOS
NB	Left Turn	120	98	81.5%	2.1	40.9	3.8	D
	Through	1490	1291	86.6%	5.3	14.8	0.5	B
	Right Turn	170	151	88.7%	1.5	7.1	1.1	A
	Subtotal	1780	1539	86.5%	5.9	15.7	0.5	B
SB	Left Turn	110	104	94.6%	0.6	61.8	28.1	E
	Through	1020	1000	98.0%	0.6	53.6	42.4	D
	Right Turn	100	100	99.9%	0.0	43.1	37.7	D
	Subtotal	1230	1204	97.8%	0.8	53.5	40.7	D
EB	Left Turn	130	125	96.5%	0.4	156.2	77.7	F
	Through	230	220	95.6%	0.7	164.7	79.9	F
	Right Turn	140	139	99.1%	0.1	141.4	81.7	F
	Subtotal	500	484	96.8%	0.7	155.8	79.9	F
WB	Left Turn	100	87	87.4%	1.3	86.6	19.4	F
	Through	200	180	90.0%	1.5	55.9	4.5	E
	Right Turn	230	215	93.7%	1.0	33.6	3.8	C
	Subtotal	530	483	91.1%	2.1	51.5	5.3	D
Total		4040	3710	91.8%	5.3	50.9	17.3	D

Intersection El Camino Real/Santa Cruz Ave

Signalized

Direction	Movement	Volume (veh/hr)			GEH	Total Delay (sec/veh)		
		Demand	Served	% Served		Average	Std. Dev.	LOS
NB	Left Turn							
	Through	1540	1305	84.8%	6.2	4.3	0.3	A
	Right Turn	140	115	82.4%	2.2	5.6	4.1	A
	Subtotal	1680	1421	84.6%	6.6	4.4	0.4	A
SB	Left Turn							
	Through	1120	1084	96.8%	1.1	41.8	13.3	D
	Right Turn	140	135	96.3%	0.4	18.0	6.6	B
	Subtotal	1260	1219	96.7%	1.2	39.1	12.4	D
EB	Left Turn	180	173	96.1%	0.5	57.4	18.9	E
	Through	200	189	94.7%	0.8	67.7	37.3	E
	Right Turn	170	168	98.8%	0.2	45.4	23.4	D
	Subtotal	550	530	96.4%	0.9	57.4	26.9	E
WB	Left Turn	80	77	96.5%	0.3	46.5	3.8	D
	Through	90	88	97.7%	0.2	52.7	6.3	D
	Right Turn	60	58	96.0%	0.3	34.7	6.4	C
	Subtotal	230	223	96.8%	0.5	45.9	4.3	D
Total		3720	3392	91.2%	5.5	27.9	6.7	C

Intersection Merrill St/Santa Cruz Ave

Unsignalized

Direction	Movement	Volume (veh/hr)			GEH	Total Delay (sec/veh)		
		Demand	Served	% Served		Average	Std. Dev.	LOS
NB	Left Turn	70	64	90.7%	0.8	16.9	7.6	C
	Through	220	207	94.3%	0.9	18.0	5.6	C
	Right Turn	10	11	105.0%	0.2	15.8	9.0	C
	Subtotal	300	281	93.8%	1.1	17.7	6.1	C
SB	Left Turn	10	10	98.0%	0.1	11.1	2.9	B
	Through	10	10	104.0%	0.1	12.9	1.5	B
	Right Turn	130	132	101.5%	0.2	7.9	1.0	A
	Subtotal	150	152	101.4%	0.2	8.4	1.0	A
EB	Left Turn	110	94	85.8%	1.5	21.5	10.3	C
	Through	40	36	89.5%	0.7	23.7	9.2	C
	Right Turn	190	176	92.7%	1.0	19.2	10.5	C
	Subtotal	340	306	90.1%	1.9	20.3	10.2	C
WB	Left Turn	10	8	84.0%	0.5	10.4	8.1	B
	Through	30	27	90.0%	0.6	11.4	8.0	B
	Right Turn	30	31	102.7%	0.1	12.1	7.7	B
	Subtotal	70	66	94.6%	0.5	11.4	6.5	B
Total		860	806	93.7%	1.9	16.5	6.8	C

SimTraffic Post-Processor
Average Results from 20 Runs
Volume and Delay by Movement

Caltrain Electrification
2020 No Project Conditions
PM Peak Hour

Intersection Ravenswood Ave/Laurel St

Unsignalized

Direction	Movement	Volume (veh/hr)			GEH	Total Delay (sec/veh)		
		Demand	Served	% Served		Average	Std. Dev.	LOS
NB	Left Turn	190	168	88.3%	1.7	271.4	121.2	F
	Through	140	130	92.6%	0.9	211.5	117.6	F
	Right Turn	50	46	91.4%	0.6	207.0	113.8	F
	Subtotal	380	343	90.3%	1.9	240.4	118.4	F
SB	Left Turn	60	55	91.8%	0.6	160.9	102.6	F
	Through	130	123	94.5%	0.6	153.7	89.4	F
	Right Turn	80	76	94.5%	0.5	160.6	100.8	F
	Subtotal	270	254	93.9%	1.0	157.0	94.6	F
EB	Left Turn	80	68	85.0%	1.4	65.0	15.3	F
	Through	840	667	79.4%	6.3	27.9	2.7	D
	Right Turn	130	105	81.0%	2.3	24.9	2.4	C
	Subtotal	1050	840	80.0%	6.8	30.6	2.2	D
WB	Left Turn	40	32	80.5%	1.3	254.3	41.0	F
	Through	640	515	80.5%	5.2	227.1	41.2	F
	Right Turn	90	71	79.3%	2.1	224.8	48.7	F
	Subtotal	770	619	80.4%	5.7	228.2	41.6	F
Total		2470	2056	83.2%	8.7	139.6	33.8	F

Intersection

High Street/University Ave

Signalized

Direction	Movement	Volume (veh/hr)			GEH	Total Delay (sec/veh)		
		Demand	Served	% Served		Average	Std. Dev.	LOS
NB	Left Turn							
	Through							
	Right Turn							
	Subtotal							
SB	Left Turn	30	28	92.3%	0.4	19.0	3.4	B
	Through	100	101	101.4%	0.1	12.1	0.8	B
	Right Turn	180	183	101.8%	0.2	10.5	1.1	B
	Subtotal	310	312	100.7%	0.1	11.8	0.9	B
EB	Left Turn							
	Through	590	597	101.2%	0.3	13.7	1.2	B
	Right Turn	400	405	101.2%	0.2	6.2	0.5	A
	Subtotal	990	1002	101.2%	0.4	10.7	0.8	B
WB	Left Turn	50	45	89.2%	0.8	49.4	4.3	D
	Through	440	452	102.7%	0.6	37.8	2.5	D
	Right Turn							
	Subtotal	490	496	101.3%	0.3	38.9	2.5	D
Total		1790	1810	101.1%	0.5	18.6	0.8	B

Intersection

Showers Drive/Pacchetti Way

Signalized

Direction	Movement	Volume (veh/hr)			GEH	Total Delay (sec/veh)		
		Demand	Served	% Served		Average	Std. Dev.	LOS
NB	Left Turn	10	8	80.0%	0.7	24.6	3.4	C
	Through	20	20	99.0%	0.0	2.4	1.7	A
	Right Turn							
	Subtotal	30	28	92.7%	0.4	8.8	2.3	A
SB	Left Turn							
	Through	170	162	95.3%	0.6	4.5	0.9	A
	Right Turn	50	46	92.8%	0.5	2.1	0.5	A
	Subtotal	220	208	94.7%	0.8	3.9	0.7	A
EB	Left Turn	20	18	90.0%	0.5	12.9	3.0	B
	Through							
	Right Turn	10	11	111.0%	0.3	3.2	0.7	A
	Subtotal	30	29	97.0%	0.2	9.1	1.6	A
WB	Left Turn							
	Through							
	Right Turn							
	Subtotal							
Total		280	265	94.8%	0.9	5.0	0.4	A

Intersection Hope Street/Evelyn Ave

Signalized

Direction	Movement	Volume (veh/hr)			GEH	Total Delay (sec/veh)		
		Demand	Served	% Served		Average	Std. Dev.	LOS
NB	Left Turn	100	100	100.0%	0.0	18.0	1.6	B
	Through							
	Right Turn	160	162	101.2%	0.1	5.3	0.3	A
	Subtotal	260	262	100.7%	0.1	10.1	0.6	B
SB	Left Turn							
	Through							
	Right Turn							
	Subtotal							
EB	Left Turn							
	Through	50	49	97.4%	0.2	2.0	0.7	A
	Right Turn	50	48	96.4%	0.3	1.1	0.2	A
	Subtotal	100	97	96.9%	0.3	1.6	0.4	A
WB	Left Turn	70	65	92.1%	0.7	3.0	0.8	A
	Through	170	172	101.3%	0.2	2.4	0.4	A
	Right Turn							
	Subtotal	240	237	98.6%	0.2	2.5	0.4	A
Total		600	596	99.3%	0.2	5.7	0.4	A

Intersection Castro Street/Villa Street

Signalized

Direction	Movement	Volume (veh/hr)			GEH	Total Delay (sec/veh)		
		Demand	Served	% Served		Average	Std. Dev.	LOS
NB	Left Turn	40	42	105.5%	0.3	51.4	8.1	D
	Through	250	254	101.7%	0.3	39.8	4.9	D
	Right Turn	40	39	96.5%	0.2	31.5	3.9	C
	Subtotal	330	335	101.5%	0.3	40.3	4.4	D
SB	Left Turn	230	226	98.4%	0.2	80.5	19.3	F
	Through	270	280	103.7%	0.6	26.2	4.4	C
	Right Turn	140	135	96.6%	0.4	20.5	4.9	C
	Subtotal	640	642	100.3%	0.1	44.3	9.6	D
EB	Left Turn	260	247	94.9%	0.8	137.2	27.6	F
	Through	230	214	93.1%	1.1	137.8	29.3	F
	Right Turn	40	37	92.3%	0.5	133.8	30.9	F
	Subtotal	530	498	93.9%	1.4	137.1	28.3	F
WB	Left Turn	30	30	98.7%	0.1	26.5	3.7	C
	Through	200	198	99.1%	0.1	19.5	2.2	B
	Right Turn	60	61	101.7%	0.1	14.0	2.4	B
	Subtotal	290	289	99.6%	0.1	19.1	1.8	B
Total		1790	1763	98.5%	0.6	65.5	10.4	E

SimTraffic Post-Processor
Average Results from 20 Runs
Volume and Delay by Movement

Caltrain Electrification
2020 No Project Conditions
PM Peak Hour

Intersection

Frances St/Evelyn Ave

Signalized

Direction	Movement	Volume (veh/hr)			GEH	Total Delay (sec/veh)		
		Demand	Served	% Served		Average	Std. Dev.	LOS
NB	Left Turn	30	29	97.0%	0.2	29.0	4.7	C
	Through	30	35	118.0%	0.9	23.6	4.7	C
	Right Turn	20	20	98.5%	0.1	13.0	3.6	B
	Subtotal	80	84	105.3%	0.5	23.2	2.5	C
SB	Left Turn	70	70	99.7%	0.0	28.7	3.9	C
	Through	20	19	93.5%	0.3	28.7	6.2	C
	Right Turn	40	40	98.8%	0.1	16.7	6.4	B
	Subtotal	130	128	98.5%	0.2	25.0	3.9	C
EB	Left Turn	60	63	104.2%	0.3	64.9	10.1	E
	Through	550	544	98.9%	0.3	30.8	6.0	C
	Right Turn	70	70	99.6%	0.0	25.0	9.2	C
	Subtotal	680	676	99.4%	0.1	33.4	6.0	C
WB	Left Turn	80	78	97.5%	0.2	63.6	9.8	E
	Through	370	405	109.5%	1.8	14.3	1.1	B
	Right Turn	130	128	98.2%	0.2	6.5	1.0	A
	Subtotal	580	611	105.3%	1.3	18.9	1.7	B
Total		1470	1499	102.0%	0.8	26.3	2.8	C

Intersection Lawrence Expressway/Kifer Road

Signalized

Direction	Movement	Volume (veh/hr)			GEH	Total Delay (sec/veh)		
		Demand	Served	% Served		Average	Std. Dev.	LOS
NB	Left Turn	110	106	95.9%	0.4	126.5	27.0	F
	Through	2060	2097	101.8%	0.8	108.8	47.9	F
	Right Turn	290	297	102.4%	0.4	149.0	54.1	F
	Subtotal	2460	2500	101.6%	0.8	114.3	47.6	F
SB	Left Turn	460	278	60.3%	9.5	485.1	37.1	F
	Through	3450	2265	65.7%	22.2	142.3	23.2	F
	Right Turn	50	32	64.6%	2.8	147.0	25.0	F
	Subtotal	3960	2575	65.0%	24.2	179.4	17.7	F
EB	Left Turn	280	229	81.8%	3.2	79.7	15.2	E
	Through	600	468	78.0%	5.7	39.5	2.8	D
	Right Turn	1100	843	76.6%	8.3	226.6	7.1	F
	Subtotal	1980	1540	77.8%	10.5	147.9	3.1	F
WB	Left Turn	640	346	54.0%	13.3	1007.5	30.1	F
	Through	930	557	59.8%	13.7	70.4	5.4	E
	Right Turn	240	155	64.6%	6.0	57.0	4.8	E
	Subtotal	1810	1057	58.4%	19.9	376.3	27.8	F
Total		10210	7672	75.1%	26.8	178.8	18.0	F

Intersection Lawrence Expressway/Reed Ave-Monroe St

Signalized

Direction	Movement	Volume (veh/hr)			GEH	Total Delay (sec/veh)		
		Demand	Served	% Served		Average	Std. Dev.	LOS
NB	Left Turn	160	144	90.2%	1.3	341.8	112.1	F
	Through	2050	2059	100.4%	0.2	45.5	2.2	D
	Right Turn	400	387	96.6%	0.7	21.2	1.9	C
	Subtotal	2610	2590	99.2%	0.4	58.5	8.1	E
SB	Left Turn	660	430	65.1%	9.9	73.0	5.3	E
	Through	4160	2779	66.8%	23.5	40.9	2.4	D
	Right Turn	370	253	68.4%	6.6	27.1	2.1	C
	Subtotal	5190	3462	66.7%	26.3	43.9	2.4	D
EB	Left Turn	310	295	95.1%	0.9	176.3	84.7	F
	Through	650	638	98.1%	0.5	225.2	82.6	F
	Right Turn	430	420	97.7%	0.5	99.2	73.1	F
	Subtotal	1390	1352	97.3%	1.0	175.7	79.4	F
WB	Left Turn	400	375	93.8%	1.3	291.4	73.8	F
	Through	350	343	98.0%	0.4	165.2	31.6	F
	Right Turn	100	93	92.9%	0.7	41.8	19.2	D
	Subtotal	850	811	95.4%	1.3	209.7	48.9	F
Total		10040	8215	81.8%	19.1	86.4	15.6	F

SimTraffic Post-Processor
Average Results from 20 Runs
Volume and Delay by Movement

Caltrain Electrification
2020 No Project Conditions
PM Peak Hour

Intersection El Camino Real/Railroad Ave

Signalized

Direction	Movement	Volume (veh/hr)			GEH	Total Delay (sec/veh)		
		Demand	Served	% Served		Average	Std. Dev.	LOS
NB	Left Turn	200	205	102.3%	0.3	45.4	8.0	D
	Through	790	804	101.7%	0.5	13.3	0.6	B
	Right Turn	20	20	101.5%	0.1	13.6	2.9	B
	Subtotal	1010	1029	101.9%	0.6	19.7	2.1	B
SB	Left Turn	100	95	94.7%	0.5	37.1	2.4	D
	Through	1350	1341	99.3%	0.3	22.4	1.8	C
	Right Turn	190	188	98.7%	0.2	26.8	2.8	C
	Subtotal	1640	1623	99.0%	0.4	23.7	1.8	C
EB	Left Turn	60	61	100.8%	0.1	28.3	1.8	C
	Through	10	11	107.0%	0.2	20.1	5.8	C
	Right Turn	140	137	98.1%	0.2	12.8	1.9	B
	Subtotal	210	209	99.3%	0.1	17.6	1.4	B
WB	Left Turn	80	76	94.4%	0.5	31.2	2.9	C
	Through	10	9	89.0%	0.4	19.3	4.9	B
	Right Turn	30	30	100.7%	0.0	5.9	1.8	A
	Subtotal	120	115	95.5%	0.5	23.5	2.3	C
Total		2980	2975	99.8%	0.1	21.9	1.3	C

Intersection Santa Clara Street/Cahill Street

Signalized

Direction	Movement	Volume (veh/hr)			GEH	Total Delay (sec/veh)		
		Demand	Served	% Served		Average	Std. Dev.	LOS
NB	Left Turn	110	104	94.2%	0.6	41.9	3.0	D
	Through	10	14	144.0%	1.3	24.8	9.2	C
	Right Turn	170	177	103.8%	0.5	24.4	2.0	C
	Subtotal	290	295	101.6%	0.3	30.5	1.4	C
SB	Left Turn	10	8	82.0%	0.6	57.8	10.5	E
	Through	10	11	108.0%	0.2	48.7	10.7	D
	Right Turn	10	10	98.0%	0.1	11.7	5.5	B
	Subtotal	30	29	96.0%	0.2	38.5	6.3	D
EB	Left Turn	10	6	55.0%	1.6	98.5	139.1	F
	Through	1140	743	65.2%	12.9	98.3	11.2	F
	Right Turn	110	67	61.3%	4.5	104.0	38.2	F
	Subtotal	1260	816	64.8%	13.8	98.8	12.0	F
WB	Left Turn	150	150	100.3%	0.0	57.5	5.9	E
	Through	780	819	105.0%	1.4	2.3	0.4	A
	Right Turn	10	11	106.0%	0.2	1.1	0.9	A
	Subtotal	940	980	104.3%	1.3	10.8	1.3	B
Total		2520	2119	84.1%	8.3	47.8	5.0	D

Intersection San Fernando Street/Montgomery Street

Signalized

Direction	Movement	Volume (veh/hr)			GEH	Total Delay (sec/veh)		
		Demand	Served	% Served		Average	Std. Dev.	LOS
NB	Left Turn							
	Through							
	Right Turn							
	Subtotal							
SB	Left Turn	90	71	78.6%	2.2	45.1	17.4	D
	Through	1400	1097	78.4%	8.6	46.9	14.3	D
	Right Turn	30	24	78.3%	1.3	55.5	20.4	E
	Subtotal	1520	1192	78.4%	8.9	46.9	14.5	D
EB	Left Turn							
	Through	210	214	101.8%	0.3	26.8	1.9	C
	Right Turn	230	207	89.9%	1.6	27.1	2.2	C
	Subtotal	440	420	95.5%	0.9	26.9	1.8	C
WB	Left Turn	120	107	89.3%	1.2	161.5	38.8	F
	Through	290	280	96.5%	0.6	155.9	38.4	F
	Right Turn							
	Subtotal	410	387	94.4%	1.2	157.5	36.7	F
Total		2370	1999	84.3%	7.9	64.3	11.8	E

SimTraffic Post-Processor
Average Results from 20 Runs
Volume and Delay by Movement

Caltrain Electrification
2020 No Project Conditions
PM Peak Hour

Intersection

Lick Avenue-Shadow Run Drive/Alma Avenue

Signalized

Direction	Movement	Volume (veh/hr)			GEH	Total Delay (sec/veh)		
		Demand	Served	% Served		Average	Std. Dev.	LOS
NB	Left Turn	30	28	93.0%	0.4	31.4	3.6	C
	Through	10	10	102.0%	0.1	26.7	7.3	C
	Right Turn	20	20	99.0%	0.0	7.3	1.8	A
	Subtotal	60	58	96.5%	0.3	22.3	3.2	C
SB	Left Turn	340	335	98.6%	0.3	57.6	10.7	E
	Through	40	37	91.5%	0.5	30.7	10.0	C
	Right Turn	110	104	94.5%	0.6	17.5	5.4	B
	Subtotal	490	476	97.1%	0.6	46.9	9.5	D
EB	Left Turn	70	70	99.7%	0.0	33.5	2.6	C
	Through	630	631	100.1%	0.0	18.5	0.8	B
	Right Turn	40	39	98.3%	0.1	17.7	1.9	B
	Subtotal	740	740	100.0%	0.0	19.8	0.8	B
WB	Left Turn	20	22	109.5%	0.4	44.0	8.3	D
	Through	650	651	100.1%	0.0	30.4	2.4	C
	Right Turn	70	72	102.7%	0.2	29.2	3.4	C
	Subtotal	740	745	100.6%	0.2	30.7	2.3	C
Total		2030	2018	99.4%	0.3	30.3	2.0	C

Intersection 7th Street/Mission Bay

Signalized

Direction	Movement	Volume (veh/hr)			GEH	Total Delay (sec/veh)		
		Demand	Served	% Served		Average	Std. Dev.	LOS
NB	Left Turn	10	12	118.0%	0.5	22.2	6.3	C
	Through	1130	1126	99.6%	0.1	10.7	0.6	B
	Right Turn	70	72	102.1%	0.2	19.9	3.0	B
	Subtotal	1210	1209	99.9%	0.0	11.4	0.6	B
SB	Left Turn	100	88	88.4%	1.2	84.1	6.4	F
	Through	290	289	99.8%	0.0	5.0	0.7	A
	Right Turn	10	11	111.0%	0.3	3.3	2.1	A
	Subtotal	400	389	97.2%	0.6	22.9	2.5	C
EB	Left Turn							
	Through							
	Right Turn							
	Subtotal							
WB	Left Turn	30	30	101.0%	0.1	3.7	3.1	A
	Through							
	Right Turn	80	75	94.0%	0.5	0.9	0.5	A
	Subtotal	110	106	95.9%	0.4	1.7	0.8	A
Total		1720	1704	99.0%	0.4	13.4	0.8	B

Intersection Berry Street/Mission Bay

Signalized

Direction	Movement	Volume (veh/hr)			GEH	Total Delay (sec/veh)		
		Demand	Served	% Served		Average	Std. Dev.	LOS
NB	Left Turn							
	Through							
	Right Turn							
	Subtotal							
SB	Left Turn							
	Through							
	Right Turn	110	105	95.5%	0.5	16.6	2.9	B
	Subtotal	110	105	95.5%	0.5	16.6	2.9	B
EB	Left Turn	170	160	94.2%	0.8	0.6	0.4	A
	Through							
	Right Turn							
	Subtotal	170	160	94.2%	0.8	0.6	0.4	A
WB	Left Turn							
	Through							
	Right Turn							
	Subtotal							
Total		280	265	94.8%	0.9	6.9	1.3	A

Intersection Main Street/Maple Street

Unsignalized

Direction	Movement	Volume (veh/hr)			GEH	Total Delay (sec/veh)		
		Demand	Served	% Served		Average	Std. Dev.	LOS
NB	Left Turn							
	Through	1020	795	78.0%	7.5	8.9	1.0	A
	Right Turn							
	Subtotal	1020	795	78.0%	7.5	8.9	1.0	A
SB	Left Turn							
	Through	520	422	81.2%	4.5	51.5	9.6	F
	Right Turn							
	Subtotal	520	422	81.2%	4.5	51.5	9.6	F
EB	Left Turn							
	Through							
	Right Turn							
	Subtotal							
WB	Left Turn							
	Through							
	Right Turn	20	19	97.0%	0.1	22.1	6.5	C
	Subtotal	20	19	97.0%	0.1	22.1	6.5	C
Total		1560	1237	79.3%	8.6	23.5	2.1	C

Intersection Main Street/Beech Street

Unsignalized

Direction	Movement	Volume (veh/hr)			GEH	Total Delay (sec/veh)		
		Demand	Served	% Served		Average	Std. Dev.	LOS
NB	Left Turn	80	80	99.4%	0.1	7.1	7.4	A
	Through	360	366	101.6%	0.3	5.7	9.4	A
	Right Turn							
	Subtotal	440	445	101.2%	0.2	6.0	9.0	A
SB	Left Turn							
	Through	360	290	80.5%	3.9	1.0	0.5	A
	Right Turn	10	8	78.0%	0.7	0.7	0.5	A
	Subtotal	370	298	80.4%	4.0	1.0	0.5	A
EB	Left Turn	60	63	105.5%	0.4	14.2	4.1	B
	Through							
	Right Turn	20	20	100.5%	0.0	8.2	3.3	A
	Subtotal	80	83	104.3%	0.4	12.8	3.7	B
WB	Left Turn							
	Through							
	Right Turn							
	Subtotal							
Total		890	826	92.8%	2.2	4.8	5.2	A

SimTraffic Post-Processor
Average Results from 20 Runs
Volume and Delay by Movement

Caltrain Electrification
2020 No Project Conditions
PM Peak Hour

Intersection Main Street/Middlefield Road

Signalized

Direction	Movement	Volume (veh/hr)			GEH	Total Delay (sec/veh)		
		Demand	Served	% Served		Average	Std. Dev.	LOS
NB	Left Turn	50	37	73.0%	2.1	97.8	22.4	F
	Through	390	749	191.9%	15.0	22.7	1.7	C
	Right Turn	28	24	83.9%	0.9	48.7	15.0	D
	Subtotal	468	809	172.8%	13.5	26.9	2.1	C
SB	Left Turn	41	31	76.1%	1.6	644.2	176.8	F
	Through	359	269	74.9%	5.1	754.2	217.0	F
	Right Turn	58	47	80.2%	1.6	389.9	161.6	F
	Subtotal	458	347	75.7%	5.5	696.0	204.4	F
EB	Left Turn	87	74	85.3%	1.4	309.1	148.1	F
	Through	247	224	90.7%	1.5	348.7	132.9	F
	Right Turn	50	45	90.2%	0.7	418.9	150.5	F
	Subtotal	384	343	89.4%	2.1	349.0	138.0	F
WB	Left Turn	46	41	89.6%	0.7	14.0	6.2	B
	Through	359	500	139.2%	6.8	5.3	0.8	A
	Right Turn	91	82	89.9%	1.0	0.6	0.3	A
	Subtotal	496	623	125.5%	5.4	5.3	1.0	A
Total		1806	2121	117.5%	7.1	181.9	48.3	F

Intersection Fair Oaks Lane/Middlefield Road

Unsignalized

Direction	Movement	Volume (veh/hr)			GEH	Total Delay (sec/veh)		
		Demand	Served	% Served		Average	Std. Dev.	LOS
NB	Left Turn	40	32	80.0%	1.3	360.6	243.8	F
	Through	20	19	94.0%	0.3	372.1	273.7	F
	Right Turn	130	125	96.5%	0.4	268.6	251.5	F
	Subtotal	190	176	92.7%	1.0	296.8	253.7	F
SB	Left Turn	10	10	95.0%	0.2	163.2	98.2	F
	Through	20	18	88.5%	0.5	140.2	67.1	F
	Right Turn	10	12	115.0%	0.5	94.9	90.0	F
	Subtotal	40	39	96.8%	0.2	133.2	79.2	F
EB	Left Turn	20	19	92.5%	0.3	9.7	2.1	A
	Through	680	674	99.1%	0.2	4.5	0.6	A
	Right Turn	40	43	108.5%	0.5	3.4	0.7	A
	Subtotal	740	736	99.4%	0.2	4.6	0.6	A
WB	Left Turn	200	181	90.7%	1.4	14.3	1.6	B
	Through	950	863	90.9%	2.9	6.0	0.5	A
	Right Turn	20	15	74.0%	1.2	5.4	2.1	A
	Subtotal	1170	1059	90.5%	3.3	7.4	0.7	A
Total		2140	2010	93.9%	2.8	32.5	20.1	D

Intersection Watkins Avenue/Middlefield Road

Unsignalized

Direction	Movement	Volume (veh/hr)			GEH	Total Delay (sec/veh)		
		Demand	Served	% Served		Average	Std. Dev.	LOS
NB	Left Turn	70	63	90.0%	0.9	159.6	76.4	F
	Through							
	Right Turn	60	60	100.2%	0.0	81.2	58.4	F
	Subtotal	130	123	94.7%	0.6	121.8	68.4	F
SB	Left Turn							
	Through							
	Right Turn							
	Subtotal							
EB	Left Turn							
	Through	720	713	99.1%	0.3	4.8	0.4	A
	Right Turn	100	102	102.0%	0.2	3.9	0.6	A
	Subtotal	820	815	99.4%	0.2	4.7	0.4	A
WB	Left Turn	80	73	91.3%	0.8	17.7	2.1	C
	Through	1100	1013	92.1%	2.7	7.7	0.4	A
	Right Turn							
	Subtotal	1180	1086	92.0%	2.8	8.3	0.3	A
Total		2130	2024	95.0%	2.3	13.8	4.3	B

SimTraffic Post-Processor
Average Results from 20 Runs
Volume and Delay by Movement

Caltrain Electrification
2020 No Project Conditions
PM Peak Hour

Intersection

Linden Avenue-Glenwood Avenue/Middlefield Road

Unsignalized

Direction	Movement	Volume (veh/hr)			GEH	Total Delay (sec/veh)		
		Demand	Served	% Served		Average	Std. Dev.	LOS
NB	Left Turn	130	38	29.2%	10.0	2545.1	397.7	F
	Through	20	5	23.0%	4.4	2143.7	524.8	F
	Right Turn	110	33	30.4%	9.0	2398.5	444.1	F
	Subtotal	260	76	29.2%	14.2	2464.6	405.2	F
SB	Left Turn	30	19	64.3%	2.2	1083.4	280.6	F
	Through	10	5	50.0%	1.8	1356.5	482.5	F
	Right Turn	60	44	73.8%	2.2	1008.9	338.2	F
	Subtotal	100	69	68.6%	3.4	1050.0	322.2	F
EB	Left Turn	50	48	96.2%	0.3	32.6	9.8	D
	Through	600	609	101.5%	0.4	8.9	1.5	A
	Right Turn	130	129	99.4%	0.1	7.6	1.2	A
	Subtotal	780	786	100.8%	0.2	10.2	2.0	B
WB	Left Turn	170	171	100.4%	0.0	20.8	1.6	C
	Through	990	986	99.6%	0.1	10.7	0.8	B
	Right Turn	90	91	101.2%	0.1	9.3	0.9	A
	Subtotal	1250	1247	99.8%	0.1	12.0	0.8	B
Total		2390	2178	91.1%	4.4	126.8	8.3	F

SimTraffic Post-Processor
Average Results from 20 Runs
Volume and Delay by Movement

Caltrain Electrification
2020 No Project Conditions
PM Peak Hour

Intersection California Street/Rengstorff Avenue

Signalized

Direction	Movement	Volume (veh/hr)			GEH	Total Delay (sec/veh)		
		Demand	Served	% Served		Average	Std. Dev.	LOS
NB	Left Turn	51	49	96.7%	0.2	95.4	6.0	F
	Through	347	347	100.0%	0.0	41.8	2.7	D
	Right Turn	85	88	103.6%	0.3	39.5	5.7	D
	Subtotal	483	484	100.3%	0.1	46.9	2.4	D
SB	Left Turn	144	143	99.2%	0.1	108.3	9.2	F
	Through	485	483	99.5%	0.1	36.4	2.7	D
	Right Turn	54	52	96.9%	0.2	32.7	4.8	C
	Subtotal	683	678	99.3%	0.2	51.2	4.0	D
EB	Left Turn	53	50	93.6%	0.5	104.4	6.7	F
	Through	293	301	102.8%	0.5	53.5	3.1	D
	Right Turn	39	41	104.9%	0.3	43.8	6.1	D
	Subtotal	385	392	101.8%	0.3	58.9	3.1	E
WB	Left Turn	178	170	95.7%	0.6	118.0	9.5	F
	Through	393	399	101.6%	0.3	48.1	3.1	D
	Right Turn	180	177	98.3%	0.2	46.3	5.2	D
	Subtotal	751	747	99.4%	0.2	63.6	4.1	E
Total		2302	2301	99.9%	0.0	55.6	1.3	E

2020 Project



Intersection Pennsylvania Street/22nd Street

Unsignalized

Direction	Movement	Volume (veh/hr)			GEH	Total Delay (sec/veh)		
		Demand	Served	% Served		Average	Std. Dev.	LOS
NB	Left Turn	60	61	101.5%	0.1	9.8	1.9	A
	Through	170	164	96.7%	0.4	10.1	1.0	B
	Right Turn	60	58	97.2%	0.2	7.6	1.2	A
	Subtotal	290	284	97.8%	0.4	9.5	1.1	A
SB	Left Turn	30	30	101.3%	0.1	7.3	1.3	A
	Through	80	83	103.5%	0.3	8.3	0.8	A
	Right Turn	20	19	94.5%	0.2	5.5	1.1	A
	Subtotal	130	132	101.6%	0.2	7.7	0.8	A
EB	Left Turn	10	9	89.0%	0.4	6.0	1.2	A
	Through	20	19	93.5%	0.3	7.1	0.7	A
	Right Turn	70	68	96.9%	0.3	4.8	0.7	A
	Subtotal	100	95	95.4%	0.5	5.3	0.5	A
WB	Left Turn	90	84	92.9%	0.7	7.7	0.5	A
	Through	40	44	108.8%	0.5	7.2	0.5	A
	Right Turn	30	31	102.7%	0.1	5.3	1.0	A
	Subtotal	160	158	98.7%	0.2	7.1	0.5	A
Total		680	669	98.4%	0.4	8.0	0.7	A

Intersection Indiana Street/22nd Street

Unsignalized

Direction	Movement	Volume (veh/hr)			GEH	Total Delay (sec/veh)		
		Demand	Served	% Served		Average	Std. Dev.	LOS
NB	Left Turn	10	10	99.0%	0.0	5.7	1.0	A
	Through	70	67	95.0%	0.4	6.6	0.6	A
	Right Turn	50	52	103.0%	0.2	4.6	0.4	A
	Subtotal	130	128	98.4%	0.2	5.7	0.4	A
SB	Left Turn	10	10	96.0%	0.1	5.4	0.5	A
	Through	20	21	103.0%	0.1	6.1	0.7	A
	Right Turn	10	9	90.0%	0.3	3.7	0.6	A
	Subtotal	40	39	98.0%	0.1	5.4	0.4	A
EB	Left Turn	30	28	92.0%	0.4	5.4	0.3	A
	Through	120	123	102.7%	0.3	5.6	0.3	A
	Right Turn	30	28	92.7%	0.4	4.2	0.4	A
	Subtotal	180	179	99.2%	0.1	5.4	0.3	A
WB	Left Turn	10	9	86.0%	0.5	4.9	0.7	A
	Through	70	70	100.1%	0.0	5.4	0.4	A
	Right Turn	10	8	81.0%	0.6	3.5	0.8	A
	Subtotal	90	87	96.4%	0.3	5.2	0.3	A
Total		440	433	98.3%	0.4	5.5	0.3	A

SimTraffic Post-Processor
Average Results from 20 Runs
Volume and Delay by Movement

Caltrain Electrification
2020 Plus Project Conditions
AM Peak Hour

Intersection

Tunnel Avenue/Blanken Avenue

Unsignalized

Direction	Movement	Volume (veh/hr)			GEH	Total Delay (sec/veh)		
		Demand	Served	% Served		Average	Std. Dev.	LOS
NB	Left Turn	50	51	101.6%	0.1	13.5	3.2	B
	Through	140	138	98.2%	0.2	14.2	0.9	B
	Right Turn	20	15	77.0%	1.1	11.6	3.3	B
	Subtotal	210	204	97.0%	0.4	13.8	1.0	B
SB	Left Turn	60	58	96.7%	0.3	10.6	1.2	B
	Through	120	126	105.3%	0.6	12.6	1.4	B
	Right Turn	10	12	120.0%	0.6	9.6	2.5	A
	Subtotal	190	196	103.3%	0.5	11.8	1.2	B
EB	Left Turn	20	17	84.0%	0.7	24.4	8.2	C
	Through	190	184	96.8%	0.4	23.9	2.5	C
	Right Turn	200	198	98.9%	0.2	22.3	2.6	C
	Subtotal	410	399	97.2%	0.6	23.1	2.6	C
WB	Left Turn	20	18	88.0%	0.6	11.2	1.8	B
	Through	80	81	101.4%	0.1	11.4	1.3	B
	Right Turn	70	77	110.0%	0.8	7.7	0.7	A
	Subtotal	170	176	103.4%	0.4	9.7	1.1	A
Total		980	974	99.4%	0.2	16.5	1.2	C

Intersection **Dubuque Avenue/Grand Avenue**

Signalized

Direction	Movement	Volume (veh/hr)			GEH	Total Delay (sec/veh)		
		Demand	Served	% Served		Average	Std. Dev.	LOS
NB	Left Turn							
	Through							
	Right Turn							
	Subtotal							
SB	Left Turn	40	38	93.8%	0.4	33.4	2.1	C
	Through							
	Right Turn	70	75	107.4%	0.6	9.6	0.4	A
	Subtotal	110	113	102.5%	0.3	17.4	2.0	B
EB	Left Turn	50	51	102.0%	0.1	42.2	4.4	D
	Through	650	648	99.7%	0.1	7.3	0.8	A
	Right Turn							
	Subtotal	700	699	99.9%	0.0	9.8	0.7	A
WB	Left Turn							
	Through	520	515	99.0%	0.2	10.0	1.3	A
	Right Turn	50	49	98.2%	0.1	7.6	1.3	A
	Subtotal	570	564	99.0%	0.2	9.8	1.2	A
Total		1380	1376	99.7%	0.1	10.4	0.7	B

Intersection

Linden Avenue-San Mateo Avenue/San Mateo Avenue

Signalized

Direction	Movement	Volume (veh/hr)			GEH	Total Delay (sec/veh)		
		Demand	Served	% Served		Average	Std. Dev.	LOS
NB	Left Turn							
	Through	100	99	98.5%	0.2	5.1	0.6	A
	Right Turn	200	206	103.2%	0.4	1.2	0.1	A
	Subtotal	300	305	101.6%	0.3	2.4	0.3	A
SB	Left Turn	130	141	108.2%	0.9	20.7	1.9	C
	Through	140	146	104.2%	0.5	3.2	0.8	A
	Right Turn							
	Subtotal	270	287	106.1%	1.0	11.8	1.3	B
EB	Left Turn							
	Through							
	Right Turn							
	Subtotal							
WB	Left Turn	190	185	97.2%	0.4	12.5	0.6	B
	Through							
	Right Turn	100	101	101.0%	0.1	6.1	0.2	A
	Subtotal	290	286	98.5%	0.3	10.3	0.4	B
Total		860	877	102.0%	0.6	8.0	0.5	A

Intersection

Herman Street/Scott Street

Unsignalized

Direction	Movement	Volume (veh/hr)			GEH	Total Delay (sec/veh)		
		Demand	Served	% Served		Average	Std. Dev.	LOS
NB	Left Turn	10	10	95.0%	0.2	11.0	3.1	B
	Through	130	132	101.8%	0.2	11.1	1.3	B
	Right Turn	150	152	101.0%	0.1	8.2	1.6	A
	Subtotal	290	293	101.2%	0.2	9.6	1.4	A
SB	Left Turn	40	39	98.5%	0.1	9.1	1.2	A
	Through	100	104	104.0%	0.4	9.9	0.7	A
	Right Turn	10	13	129.0%	0.9	6.4	1.5	A
	Subtotal	150	156	104.2%	0.5	9.4	0.7	A
EB	Left Turn	10	12	123.0%	0.7	6.4	2.1	A
	Through	30	33	108.7%	0.5	9.3	1.6	A
	Right Turn	10	10	102.0%	0.1	3.9	1.0	A
	Subtotal	50	55	110.2%	0.7	7.6	1.5	A
WB	Left Turn	60	63	104.2%	0.3	0.3	0.1	A
	Through	10	11	107.0%	0.2	0.4	0.2	A
	Right Turn	60	60	99.3%	0.1	0.2	0.1	A
	Subtotal	130	133	102.2%	0.2	0.2	0.0	A
Total		620	638	102.8%	0.7	7.4	0.7	A

Intersection **Montgomery Avenue/Scott Street**

Unsignalized

Direction	Movement	Volume (veh/hr)			GEH	Total Delay (sec/veh)		
		Demand	Served	% Served		Average	Std. Dev.	LOS
NB	Left Turn	20	20	100.5%	0.0	7.5	1.2	A
	Through	10	10	102.0%	0.1	7.2	1.3	A
	Right Turn	10	10	104.0%	0.1	3.6	0.4	A
	Subtotal	40	41	101.8%	0.1	6.4	0.6	A
SB	Left Turn	10	9	90.0%	0.3	5.1	1.1	A
	Through	10	10	104.0%	0.1	6.1	1.0	A
	Right Turn	20	20	100.5%	0.0	3.3	0.5	A
	Subtotal	40	40	98.8%	0.1	4.5	0.7	A
EB	Left Turn	40	39	98.5%	0.1	2.2	0.3	A
	Through	150	150	100.1%	0.0	0.7	0.1	A
	Right Turn	30	34	113.7%	0.7	0.4	0.2	A
	Subtotal	220	224	101.6%	0.2	0.9	0.1	A
WB	Left Turn	10	9	94.0%	0.2	2.3	0.6	A
	Through	90	92	101.9%	0.2	0.3	0.1	A
	Right Turn	10	11	111.0%	0.3	0.2	0.2	A
	Subtotal	110	112	102.0%	0.2	0.5	0.1	A
Total		410	416	101.5%	0.3	1.7	0.1	A

Intersection **Driveway-Dollar Avenue/Linden Avenue**

Signalized

Direction	Movement	Volume (veh/hr)			GEH	Total Delay (sec/veh)		
		Demand	Served	% Served		Average	Std. Dev.	LOS
NB	Left Turn	70	69	98.4%	0.1	24.7	2.4	C
	Through							
	Right Turn	70	71	101.7%	0.1	18.2	3.5	B
	Subtotal	140	140	100.1%	0.0	21.3	2.8	C
SB	Left Turn	10	11	114.0%	0.4	40.3	10.0	D
	Through							
	Right Turn							
	Subtotal	10	11	114.0%	0.4	40.3	10.0	D
EB	Left Turn							
	Through	190	201	106.0%	0.8	28.8	3.6	C
	Right Turn	80	84	104.6%	0.4	20.0	3.8	B
	Subtotal	270	285	105.6%	0.9	26.2	3.3	C
WB	Left Turn	40	39	97.3%	0.2	2.4	1.4	A
	Through	150	151	100.8%	0.1	2.9	0.9	A
	Right Turn	10	10	95.0%	0.2	2.3	5.5	A
	Subtotal	200	200	99.8%	0.0	2.8	0.9	A
Total		620	636	102.6%	0.6	18.0	2.2	B

Intersection

San Mateo Avenue/San Bruno Avenue

Signalized

Direction	Movement	Volume (veh/hr)			GEH	Total Delay (sec/veh)		
		Demand	Served	% Served		Average	Std. Dev.	LOS
NB	Left Turn	10	9	89.0%	0.4	33.5	7.2	C
	Through	100	96	96.0%	0.4	29.0	1.7	C
	Right Turn	270	276	102.3%	0.4	10.9	0.6	B
	Subtotal	380	381	100.3%	0.1	16.0	0.8	B
SB	Left Turn	90	86	95.2%	0.5	35.2	2.6	D
	Through	50	50	99.6%	0.0	24.7	2.7	C
	Right Turn	40	41	101.3%	0.1	8.6	2.1	A
	Subtotal	180	176	97.8%	0.3	26.2	1.6	C
EB	Left Turn	50	48	95.4%	0.3	23.3	3.2	C
	Through	370	360	97.3%	0.5	7.9	1.1	A
	Right Turn	10	9	90.0%	0.3	5.6	6.7	A
	Subtotal	430	417	96.9%	0.7	9.6	1.0	A
WB	Left Turn	220	212	96.4%	0.5	44.8	2.2	D
	Through	370	366	99.0%	0.2	25.5	2.0	C
	Right Turn	130	132	101.8%	0.2	20.4	2.1	C
	Subtotal	720	711	98.7%	0.3	30.3	1.8	C
Total		1710	1684	98.5%	0.6	21.5	0.9	C

Intersection

El Camino Real/Millbrae Avenue

Signalized

Direction	Movement	Volume (veh/hr)			GEH	Total Delay (sec/veh)		
		Demand	Served	% Served		Average	Std. Dev.	LOS
NB	Left Turn	40	38	95.0%	0.3	71.2	9.4	E
	Through	400	406	101.6%	0.3	37.8	2.1	D
	Right Turn	570	570	100.0%	0.0	5.9	0.6	A
	Subtotal	1010	1014	100.4%	0.1	21.2	1.7	C
SB	Left Turn	690	624	90.4%	2.6	310.3	26.2	F
	Through	800	759	94.8%	1.5	149.3	23.2	F
	Right Turn	40	33	83.0%	1.1	151.8	27.1	F
	Subtotal	1530	1416	92.5%	3.0	220.4	24.2	F
EB	Left Turn	60	60	100.0%	0.0	117.9	25.1	F
	Through	780	778	99.7%	0.1	78.6	24.5	E
	Right Turn	30	30	99.0%	0.1	78.8	27.4	E
	Subtotal	870	868	99.7%	0.1	81.4	24.6	F
WB	Left Turn	450	451	100.3%	0.1	122.6	43.8	F
	Through	210	221	105.3%	0.8	36.6	2.4	D
	Right Turn	530	530	100.0%	0.0	11.3	0.4	B
	Subtotal	1190	1202	101.0%	0.4	57.9	16.8	E
Total		4600	4500	97.8%	1.5	105.4	7.7	F

Intersection

Rollins Road/Millbrae Avenue

Signalized

Direction	Movement	Volume (veh/hr)			GEH	Total Delay (sec/veh)		
		Demand	Served	% Served		Average	Std. Dev.	LOS
NB	Left Turn	120	124	103.2%	0.3	63.8	44.9	E
	Through	140	137	98.0%	0.2	205.8	115.5	F
	Right Turn	250	243	97.0%	0.5	106.4	95.2	F
	Subtotal	510	504	98.7%	0.3	124.0	90.6	F
SB	Left Turn	210	209	99.3%	0.1	27.4	1.5	C
	Through	20	21	102.5%	0.1	26.1	5.3	C
	Right Turn	80	83	104.3%	0.4	6.7	1.1	A
	Subtotal	310	312	100.8%	0.1	21.8	1.4	C
EB	Left Turn	380	372	97.9%	0.4	96.1	29.1	F
	Through	1340	1298	96.8%	1.2	35.0	1.8	C
	Right Turn	320	307	95.9%	0.7	20.9	1.7	C
	Subtotal	2040	1977	96.9%	1.4	44.5	6.2	D
WB	Left Turn	440	431	97.9%	0.4	58.4	9.0	E
	Through	990	1004	101.4%	0.4	44.3	3.3	D
	Right Turn	480	465	96.9%	0.7	13.7	2.1	B
	Subtotal	1910	1900	99.5%	0.2	40.0	3.3	D
Total		4770	4693	98.4%	1.1	49.4	8.8	D

Intersection **California Drive/Oak Grove Avenue**

Signalized

Direction	Movement	Volume (veh/hr)			GEH	Total Delay (sec/veh)		
		Demand	Served	% Served		Average	Std. Dev.	LOS
NB	Left Turn	30	27	91.3%	0.5	60.5	7.2	E
	Through	480	469	97.6%	0.5	29.9	2.3	C
	Right Turn	230	232	100.7%	0.1	10.1	2.4	B
	Subtotal	740	728	98.3%	0.5	24.7	2.1	C
SB	Left Turn	110	110	100.4%	0.0	65.1	6.0	E
	Through	630	631	100.2%	0.0	26.6	1.7	C
	Right Turn	50	50	100.6%	0.0	11.6	0.9	B
	Subtotal	790	792	100.2%	0.1	31.0	1.8	C
EB	Left Turn	80	77	96.1%	0.3	159.5	76.2	F
	Through	310	307	99.1%	0.2	168.3	76.3	F
	Right Turn	30	28	94.3%	0.3	153.7	77.6	F
	Subtotal	420	412	98.2%	0.4	165.6	76.2	F
WB	Left Turn	160	136	84.9%	2.0	31.5	1.8	C
	Through	100	96	95.5%	0.5	32.0	2.9	C
	Right Turn	90	72	79.7%	2.0	15.8	2.7	B
	Subtotal	350	303	86.6%	2.6	27.9	1.2	C
Total		2300	2235	97.2%	1.4	53.2	14.7	D

Intersection **Carolan Avenue/Oak Grove Avenue**

Unsignalized

Direction	Movement	Volume (veh/hr)			GEH	Total Delay (sec/veh)		
		Demand	Served	% Served		Average	Std. Dev.	LOS
NB	Left Turn	50	38	76.4%	1.8	408.2	71.2	F
	Through	120	95	79.3%	2.4	345.6	86.3	F
	Right Turn	40	34	85.0%	1.0	351.8	96.6	F
	Subtotal	210	167	79.7%	3.1	359.9	82.2	F
SB	Left Turn	10	9	93.0%	0.2	96.6	59.5	F
	Through	120	115	95.5%	0.5	110.7	52.5	F
	Right Turn	170	154	90.7%	1.2	252.2	70.5	F
	Subtotal	300	278	92.7%	1.3	189.1	62.9	F
EB	Left Turn	380	377	99.2%	0.1	0.5	0.1	A
	Through	160	172	107.6%	0.9	1.2	0.1	A
	Right Turn	110	108	98.5%	0.2	0.2	0.1	A
	Subtotal	650	658	101.2%	0.3	0.6	0.1	A
WB	Left Turn	20	15	74.0%	1.2	435.4	136.3	F
	Through	130	105	80.8%	2.3	456.6	96.6	F
	Right Turn	20	14	70.5%	1.4	463.1	149.3	F
	Subtotal	170	134	78.8%	2.9	456.1	100.5	F
Total		1330	1237	93.0%	2.6	140.2	16.1	F

Intersection **California Drive/North Lane**

Unsignalized

Direction	Movement	Volume (veh/hr)			GEH	Total Delay (sec/veh)		
		Demand	Served	% Served		Average	Std. Dev.	LOS
NB	Left Turn							
	Through	720	710	98.6%	0.4	1.3	0.1	A
	Right Turn	190	197	103.6%	0.5	3.0	1.0	A
	Subtotal	910	907	99.6%	0.1	1.6	0.3	A
SB	Left Turn	120	110	91.5%	1.0	41.4	27.4	E
	Through	660	647	98.0%	0.5	3.2	0.7	A
	Right Turn							
	Subtotal	780	757	97.0%	0.8	8.7	3.9	A
EB	Left Turn							
	Through							
	Right Turn							
	Subtotal							
WB	Left Turn	60	56	93.0%	0.6	35.3	7.1	E
	Through							
	Right Turn	110	106	96.5%	0.4	5.1	0.5	A
	Subtotal	170	162	95.3%	0.6	15.5	2.8	C
Total		1860	1825	98.1%	0.8	5.8	1.7	A

Intersection **Carolan Avenue/North Lane**

Unsignalized

Direction	Movement	Volume (veh/hr)			GEH	Total Delay (sec/veh)		
		Demand	Served	% Served		Average	Std. Dev.	LOS
NB	Left Turn	80	73	91.6%	0.8	46.1	14.2	E
	Through	150	142	94.9%	0.6	33.6	27.4	D
	Right Turn	20	21	103.0%	0.1	44.1	50.6	E
	Subtotal	250	236	94.5%	0.9	38.5	24.9	E
SB	Left Turn	10	9	93.0%	0.2	16.2	6.0	C
	Through	130	127	97.4%	0.3	20.2	4.4	C
	Right Turn	90	85	94.8%	0.5	14.5	5.4	B
	Subtotal	230	221	96.2%	0.6	17.9	4.0	C
EB	Left Turn	200	194	97.1%	0.4	2.7	2.3	A
	Through	20	22	110.0%	0.4	0.8	0.4	A
	Right Turn	90	93	103.8%	0.4	0.5	0.2	A
	Subtotal	310	310	99.9%	0.0	1.9	1.5	A
WB	Left Turn							
	Through							
	Right Turn							
	Subtotal							
Total		790	767	97.1%	0.8	17.6	7.2	C

Intersection Anita Road/Peninsula Avenue

Unsignalized

Direction	Movement	Volume (veh/hr)			GEH	Total Delay (sec/veh)		
		Demand	Served	% Served		Average	Std. Dev.	LOS
NB	Left Turn							
	Through							
	Right Turn							
	Subtotal							
SB	Left Turn	30	32	108.0%	0.4	15.3	4.2	C
	Through							
	Right Turn	30	32	107.7%	0.4	13.3	4.7	B
	Subtotal	60	65	107.8%	0.6	14.4	3.4	B
EB	Left Turn	40	41	102.5%	0.2	8.0	2.0	A
	Through	570	595	104.5%	1.1	0.7	0.3	A
	Right Turn							
	Subtotal	610	636	104.3%	1.1	1.2	0.4	A
WB	Left Turn							
	Through	530	550	103.7%	0.8	5.1	1.0	A
	Right Turn	70	66	94.7%	0.4	3.8	1.8	A
	Subtotal	600	616	102.6%	0.6	4.9	0.9	A
Total		1270	1317	103.7%	1.3	3.6	0.6	A

Intersection Woodside Way/Villa Terrace

Unsignalized

Direction	Movement	Volume (veh/hr)			GEH	Total Delay (sec/veh)		
		Demand	Served	% Served		Average	Std. Dev.	LOS
NB	Left Turn	10	8	84.0%	0.5	5.5	0.9	A
	Through	30	30	98.7%	0.1	6.0	0.3	A
	Right Turn	10	12	121.0%	0.6	2.8	0.4	A
	Subtotal	50	50	100.2%	0.0	5.2	0.4	A
SB	Left Turn	10	10	103.0%	0.1	6.1	1.1	A
	Through	20	25	125.0%	1.1	6.2	1.1	A
	Right Turn	60	61	101.2%	0.1	3.4	0.2	A
	Subtotal	90	96	106.7%	0.6	4.4	0.5	A
EB	Left Turn	50	52	104.2%	0.3	2.0	0.2	A
	Through	30	33	109.0%	0.5	0.7	0.4	A
	Right Turn	10	11	109.0%	0.3	0.5	0.4	A
	Subtotal	90	96	106.3%	0.6	1.4	0.2	A
WB	Left Turn	10	12	122.0%	0.7	1.9	0.1	A
	Through	20	19	93.0%	0.3	0.4	0.1	A
	Right Turn	20	20	97.5%	0.1	0.2	0.1	A
	Subtotal	50	50	100.6%	0.0	0.7	0.1	A
Total		280	292	104.3%	0.7	2.9	0.2	A

Intersection N. San Mateo Drive/Villa Terrace

Unsignalized

Direction	Movement	Volume (veh/hr)			GEH	Total Delay (sec/veh)		
		Demand	Served	% Served		Average	Std. Dev.	LOS
NB	Left Turn	20	18	91.0%	0.4	4.5	1.2	A
	Through	440	458	104.0%	0.8	0.6	0.1	A
	Right Turn	40	43	108.3%	0.5	0.6	0.2	A
	Subtotal	500	519	103.8%	0.8	0.7	0.1	A
SB	Left Turn	20	18	91.5%	0.4	5.3	0.8	A
	Through	520	524	100.8%	0.2	2.3	0.0	A
	Right Turn	20	20	101.0%	0.0	2.2	0.8	A
	Subtotal	560	563	100.5%	0.1	2.4	0.1	A
EB	Left Turn	10	11	112.0%	0.4	11.7	3.8	B
	Through	30	32	106.7%	0.4	14.5	1.9	B
	Right Turn	20	21	103.5%	0.2	6.1	1.7	A
	Subtotal	60	64	106.5%	0.5	11.4	1.3	B
WB	Left Turn	40	37	91.5%	0.5	11.4	1.6	B
	Through	30	32	106.3%	0.3	15.3	2.6	C
	Right Turn	20	20	99.5%	0.0	5.7	1.3	A
	Subtotal	90	88	98.2%	0.2	11.6	1.8	B
Total		1210	1234	102.0%	0.7	2.8	0.2	A

Intersection Arundel Road/Peninsula Avenue

Unsignalized

Direction	Movement	Volume (veh/hr)			GEH	Total Delay (sec/veh)		
		Demand	Served	% Served		Average	Std. Dev.	LOS
NB	Left Turn	30	29	97.7%	0.1	25.9	4.1	D
	Through	10	13	125.0%	0.7	19.5	5.8	C
	Right Turn	60	61	102.3%	0.2	11.9	2.5	B
	Subtotal	100	103	103.2%	0.3	16.8	2.8	C
SB	Left Turn	20	20	98.5%	0.1	16.1	4.9	C
	Through	10	10	104.0%	0.1	17.4	3.5	C
	Right Turn	10	10	96.0%	0.1	9.4	3.6	A
	Subtotal	40	40	99.3%	0.0	14.5	2.0	B
EB	Left Turn	10	10	95.0%	0.2	4.9	1.6	A
	Through	550	581	105.6%	1.3	0.6	0.1	A
	Right Turn	40	44	109.3%	0.6	0.6	0.2	A
	Subtotal	600	634	105.7%	1.4	0.7	0.1	A
WB	Left Turn	40	40	99.5%	0.0	6.2	0.9	A
	Through	560	558	99.6%	0.1	2.7	0.6	A
	Right Turn	30	29	96.7%	0.2	1.9	0.7	A
	Subtotal	630	626	99.4%	0.1	2.9	0.6	A
Total		1370	1404	102.4%	0.9	3.2	0.3	A

SimTraffic Post-Processor
Average Results from 20 Runs
Volume and Delay by Movement

Caltrain Electrification
2020 Plus Project Conditions
AM Peak Hour

Intersection **Railroad Ave/1st Ave**

Unsignalized

Direction	Movement	Volume (veh/hr)			GEH	Total Delay (sec/veh)		
		Demand	Served	% Served		Average	Std. Dev.	LOS
NB	Left Turn	10	11	106.0%	0.2	12.5	4.6	B
	Through	10	12	120.0%	0.6	8.7	1.3	A
	Right Turn	10	10	100.0%	0.0	4.9	0.3	A
	Subtotal	30	33	108.7%	0.5	8.9	1.9	A
SB	Left Turn							
	Through							
	Right Turn							
	Subtotal							
EB	Left Turn	20	19	92.5%	0.3	1.8	0.6	A
	Through	60	62	103.8%	0.3	0.3	0.1	A
	Right Turn							
	Subtotal	80	81	101.0%	0.1	0.6	0.2	A
WB	Left Turn							
	Through	160	156	97.7%	0.3	5.4	1.1	A
	Right Turn	10	10	100.0%	0.0	4.2	3.4	A
	Subtotal	170	166	97.8%	0.3	5.3	1.1	A
Total		280	280	99.9%	0.0	4.4	0.7	A

Intersection **S. B. St/1st Ave**

Signalized

Direction	Movement	Volume (veh/hr)			GEH	Total Delay (sec/veh)		
		Demand	Served	% Served		Average	Std. Dev.	LOS
NB	Left Turn	20	17	86.5%	0.6	15.5	4.9	B
	Through	150	144	95.7%	0.5	8.1	2.0	A
	Right Turn	20	23	116.5%	0.7	5.9	3.3	A
	Subtotal	190	184	96.9%	0.4	8.6	2.2	A
SB	Left Turn	50	48	95.4%	0.3	18.3	4.3	B
	Through	210	214	101.8%	0.3	11.9	2.0	B
	Right Turn	10	11	110.0%	0.3	11.0	6.7	B
	Subtotal	270	272	100.9%	0.1	13.1	2.4	B
EB	Left Turn	10	8	81.0%	0.6	43.3	8.2	D
	Through	30	32	106.0%	0.3	33.1	5.4	C
	Right Turn	20	19	93.0%	0.3	12.8	8.2	B
	Subtotal	60	59	97.5%	0.2	28.0	4.1	C
WB	Left Turn	30	28	94.0%	0.3	40.6	7.2	D
	Through	50	51	101.0%	0.1	32.0	3.9	C
	Right Turn	60	57	94.2%	0.5	18.2	5.0	B
	Subtotal	140	135	96.6%	0.4	28.2	5.0	C
Total		660	650	98.5%	0.4	16.3	1.9	B

SimTraffic Post-Processor
Average Results from 20 Runs
Volume and Delay by Movement

Caltrain Electrification
2020 Plus Project Conditions
AM Peak Hour

Intersection

Transit Center Way/1st St

Unsignalized

Direction	Movement	Volume (veh/hr)			GEH	Total Delay (sec/veh)		
		Demand	Served	% Served		Average	Std. Dev.	LOS
NB	Left Turn	10	8	82.0%	0.6	5.2	1.6	A
	Through	10	9	85.0%	0.5	3.5	1.0	A
	Right Turn	10	9	94.0%	0.2	3.8	1.6	A
	Subtotal	30	26	87.0%	0.7	4.2	0.5	A
SB	Left Turn							
	Through							
	Right Turn							
	Subtotal							
EB	Left Turn	20	22	109.0%	0.4	3.1	0.8	A
	Through	70	71	101.3%	0.1	1.9	0.7	A
	Right Turn	10	11	112.0%	0.4	1.1	0.5	A
	Subtotal	100	104	103.9%	0.4	2.0	0.6	A
WB	Left Turn							
	Through	130	128	98.2%	0.2	1.3	0.4	A
	Right Turn	40	42	103.8%	0.2	0.3	0.2	A
	Subtotal	170	169	99.5%	0.1	1.0	0.4	A
Total		300	299	99.7%	0.0	1.7	0.4	A

Intersection **Railroad Avenue/9th Avenue**

Unsignalized

Direction	Movement	Volume (veh/hr)			GEH	Total Delay (sec/veh)		
		Demand	Served	% Served		Average	Std. Dev.	LOS
NB	Left Turn	30	29	97.3%	0.1	54.4	18.7	F
	Through							
	Right Turn	20	20	98.5%	0.1	29.6	14.4	D
	Subtotal	50	49	97.8%	0.2	44.5	15.5	E
SB	Left Turn							
	Through							
	Right Turn							
	Subtotal							
EB	Left Turn							
	Through	460	452	98.3%	0.4	1.0	0.1	A
	Right Turn	90	90	100.3%	0.0	0.2	0.1	A
	Subtotal	550	543	98.6%	0.3	0.9	0.1	A
WB	Left Turn	10	11	112.0%	0.4	12.5	4.4	B
	Through	500	503	100.7%	0.1	6.0	1.4	A
	Right Turn							
	Subtotal	510	515	100.9%	0.2	6.1	1.5	A
Total		1110	1106	99.6%	0.1	5.2	1.1	A

Intersection **S B Street/9th Avenue**

Signalized

Direction	Movement	Volume (veh/hr)			GEH	Total Delay (sec/veh)		
		Demand	Served	% Served		Average	Std. Dev.	LOS
NB	Left Turn	10	9	86.0%	0.5	22.3	6.4	C
	Through	110	109	99.2%	0.1	19.5	2.1	B
	Right Turn	160	156	97.3%	0.3	12.0	1.6	B
	Subtotal	280	273	97.6%	0.4	15.3	1.6	B
SB	Left Turn	80	79	98.5%	0.1	31.6	7.2	C
	Through	50	54	108.8%	0.6	13.7	1.9	B
	Right Turn	40	38	95.8%	0.3	5.7	1.4	A
	Subtotal	170	172	100.9%	0.1	20.2	4.3	C
EB	Left Turn	40	37	93.0%	0.5	31.2	10.1	C
	Through	310	304	98.1%	0.3	24.9	7.5	C
	Right Turn	10	10	98.0%	0.1	15.0	6.6	B
	Subtotal	360	351	97.6%	0.5	25.3	7.5	C
WB	Left Turn	110	113	103.0%	0.3	16.1	1.9	B
	Through	310	315	101.6%	0.3	9.7	0.4	A
	Right Turn	100	96	95.5%	0.5	5.5	1.1	A
	Subtotal	520	524	100.7%	0.2	10.3	0.6	B
Total		1330	1320	99.2%	0.3	16.6	1.8	B

Intersection

Concar Drive/SR 92 WB Ramps

Signalized

Direction	Movement	Volume (veh/hr)			GEH	Total Delay (sec/veh)		
		Demand	Served	% Served		Average	Std. Dev.	LOS
NB	Left Turn	30	30	98.7%	0.1	24.7	1.3	C
	Through	50	51	101.2%	0.1	23.4	2.2	C
	Right Turn							
	Subtotal	80	80	100.3%	0.0	23.8	1.6	C
SB	Left Turn	10	9	89.0%	0.4	18.3	3.6	B
	Through	10	10	102.0%	0.1	14.3	3.5	B
	Right Turn	10	11	107.0%	0.2	4.0	1.7	A
	Subtotal	30	30	99.3%	0.0	12.0	2.4	B
EB	Left Turn	10	10	104.0%	0.1	25.4	5.2	C
	Through	70	71	102.0%	0.2	25.1	2.0	C
	Right Turn	40	40	99.0%	0.1	13.8	3.0	B
	Subtotal	120	121	101.2%	0.1	21.4	2.6	C
WB	Left Turn	750	723	96.4%	1.0	3.1	0.3	A
	Through	30	35	115.0%	0.8	4.3	0.5	A
	Right Turn	30	30	99.3%	0.0	1.1	0.2	A
	Subtotal	810	787	97.2%	0.8	3.0	0.3	A
Total		1040	1018	97.9%	0.7	7.1	0.7	A

SimTraffic Post-Processor
Average Results from 20 Runs
Volume and Delay by Movement

Caltrain Electrification
2020 Plus Project Conditions
AM Peak Hour

Intersection

Delaware Ave/25th Ave

Signalized

Direction	Movement	Volume (veh/hr)			GEH	Total Delay (sec/veh)		
		Demand	Served	% Served		Average	Std. Dev.	LOS
NB	Left Turn	50	51	101.0%	0.1	29.8	3.6	C
	Through	20	21	103.5%	0.2	10.4	5.3	B
	Right Turn							
	Subtotal	70	71	101.7%	0.1	24.0	3.5	C
SB	Left Turn							
	Through	30	28	94.7%	0.3	12.0	4.0	B
	Right Turn	710	712	100.3%	0.1	5.3	0.4	A
	Subtotal	740	740	100.0%	0.0	5.6	0.4	A
EB	Left Turn	590	603	102.1%	0.5	27.2	1.5	C
	Through							
	Right Turn	40	40	99.3%	0.0	8.2	2.1	A
	Subtotal	630	642	102.0%	0.5	26.1	1.4	C
WB	Left Turn							
	Through							
	Right Turn							
	Subtotal							
Total		1440	1454	101.0%	0.4	15.5	0.6	B

Intersection

El Camino Real/25th Ave

Signalized

Direction	Movement	Volume (veh/hr)			GEH	Total Delay (sec/veh)		
		Demand	Served	% Served		Average	Std. Dev.	LOS
NB	Left Turn	60	58	97.0%	0.2	65.4	14.5	E
	Through	1020	1021	100.0%	0.0	24.3	1.4	C
	Right Turn	330	341	103.3%	0.6	28.7	2.9	C
	Subtotal	1410	1420	100.7%	0.3	27.1	1.5	C
SB	Left Turn	80	85	106.1%	0.5	54.5	6.5	D
	Through	1070	1055	98.6%	0.5	19.9	0.9	B
	Right Turn	60	58	96.3%	0.3	18.6	1.4	B
	Subtotal	1210	1197	99.0%	0.4	22.3	0.9	C
EB	Left Turn	150	151	100.4%	0.0	37.7	6.6	D
	Through	220	217	98.6%	0.2	69.4	13.1	E
	Right Turn	40	43	107.5%	0.5	26.5	8.3	C
	Subtotal	410	411	100.1%	0.0	53.3	10.1	D
WB	Left Turn	530	531	100.1%	0.0	39.9	4.1	D
	Through	130	129	98.8%	0.1	47.3	4.4	D
	Right Turn	100	103	102.5%	0.2	25.7	3.2	C
	Subtotal	760	762	100.2%	0.1	39.3	3.8	D
Total		3790	3789	100.0%	0.0	30.9	1.6	C

Intersection El Camino Real/31st Street

Signalized

Direction	Movement	Volume (veh/hr)			GEH	Total Delay (sec/veh)		
		Demand	Served	% Served		Average	Std. Dev.	LOS
NB	Left Turn	70	69	98.7%	0.1	63.1	12.9	E
	Through	1390	1363	98.1%	0.7	19.5	0.9	B
	Right Turn	120	116	96.5%	0.4	2.4	0.3	A
	Subtotal	1580	1548	98.0%	0.8	20.2	1.2	C
SB	Left Turn	60	58	97.3%	0.2	54.8	8.5	D
	Through	1300	1288	99.0%	0.3	21.2	1.5	C
	Right Turn	120	123	102.6%	0.3	14.6	2.3	B
	Subtotal	1480	1469	99.3%	0.3	22.0	1.5	C
EB	Left Turn	120	118	98.3%	0.2	39.5	5.2	D
	Through	50	50	100.6%	0.0	50.8	5.0	D
	Right Turn	170	173	101.9%	0.3	6.3	0.7	A
	Subtotal	340	342	100.5%	0.1	24.5	3.2	C
WB	Left Turn	20	19	95.0%	0.2	22.4	5.7	C
	Through	60	61	101.8%	0.1	16.6	2.2	B
	Right Turn	60	62	103.8%	0.3	12.1	1.2	B
	Subtotal	140	142	101.7%	0.2	15.5	1.9	B
Total		3540	3501	98.9%	0.7	21.2	1.3	C

Intersection El Camino Real/Hillsdale Blvd

Signalized

Direction	Movement	Volume (veh/hr)			GEH	Total Delay (sec/veh)		
		Demand	Served	% Served		Average	Std. Dev.	LOS
NB	Left Turn							
	Through							
	Right Turn							
	Subtotal							
SB	Left Turn	350	352	100.6%	0.1	37.8	1.9	D
	Through							
	Right Turn	70	71	101.4%	0.1	6.2	1.0	A
	Subtotal	420	423	100.7%	0.1	32.5	1.6	C
EB	Left Turn							
	Through	460	466	101.3%	0.3	58.8	19.1	E
	Right Turn	80	81	101.0%	0.1	21.6	13.0	C
	Subtotal	540	547	101.2%	0.3	53.3	18.6	D
WB	Left Turn	420	389	92.7%	1.5	14.6	1.5	B
	Through	720	678	94.2%	1.6	12.9	1.3	B
	Right Turn							
	Subtotal	1140	1067	93.6%	2.2	13.5	0.8	B
Total		2970	2910	98.0%	1.1	86.6	5.1	F

SimTraffic Post-Processor
Average Results from 20 Runs
Volume and Delay by Movement

Caltrain Electrification
2020 Plus Project Conditions
AM Peak Hour

Intersection

Curtiss Street/Hillsdale Blvd

Signalized

Direction	Movement	Volume (veh/hr)			GEH	Total Delay (sec/veh)		
		Demand	Served	% Served		Average	Std. Dev.	LOS
NB	Left Turn	140	142	101.4%	0.2	51.9	4.6	D
	Through	10	10	99.0%	0.0	49.5	10.8	D
	Right Turn	130	132	101.4%	0.2	27.2	4.1	C
	Subtotal	280	284	101.3%	0.2	40.3	4.1	D
SB	Left Turn	40	39	98.5%	0.1	40.1	5.5	D
	Through	10	10	102.0%	0.1	33.2	11.0	C
	Right Turn	40	39	97.3%	0.2	30.7	4.4	C
	Subtotal	90	89	98.3%	0.2	35.1	4.8	D
EB	Left Turn	10	9	91.0%	0.3	37.0	9.8	D
	Through	1150	1167	101.4%	0.5	13.3	1.9	B
	Right Turn	100	100	100.3%	0.0	13.9	2.8	B
	Subtotal	1260	1276	101.3%	0.4	13.5	2.0	B
WB	Left Turn	40	42	105.5%	0.3	87.7	15.1	F
	Through	1200	1147	95.6%	1.6	62.7	14.2	E
	Right Turn	30	26	85.3%	0.8	59.7	19.9	E
	Subtotal	1270	1214	95.6%	1.6	63.5	14.0	E
Total		2900	2862	98.7%	0.7	38.1	6.3	D

Intersection

El Camino Real/Ralston Avenue

Signalized

Direction	Movement	Volume (veh/hr)			GEH	Total Delay (sec/veh)		
		Demand	Served	% Served		Average	Std. Dev.	LOS
NB	Left Turn	90	87	96.6%	0.3	140.3	31.8	F
	Through	720	724	100.6%	0.2	127.7	38.0	F
	Right Turn	190	195	102.8%	0.4	11.3	4.3	B
	Subtotal	1000	1007	100.7%	0.2	106.3	30.8	F
SB	Left Turn	340	342	100.5%	0.1	128.6	38.0	F
	Through	960	982	102.3%	0.7	59.2	13.1	E
	Right Turn	90	88	97.9%	0.2	26.8	11.4	C
	Subtotal	1390	1412	101.6%	0.6	74.0	18.7	E
EB	Left Turn	160	145	90.6%	1.2	306.1	25.5	F
	Through	780	684	87.7%	3.5	337.3	33.9	F
	Right Turn	200	181	90.5%	1.4	373.2	33.0	F
	Subtotal	1140	1010	88.6%	4.0	339.3	32.3	F
WB	Left Turn	160	154	96.1%	0.5	55.6	3.0	E
	Through	540	547	101.2%	0.3	91.5	17.6	F
	Right Turn	170	169	99.2%	0.1	10.8	1.2	B
	Subtotal	870	869	99.9%	0.0	69.6	12.1	E
Total		4400	4298	97.7%	1.6	143.1	12.6	F

SimTraffic Post-Processor
Average Results from 20 Runs
Volume and Delay by Movement

Caltrain Electrification
2020 Plus Project Conditions
AM Peak Hour

Intersection

El Camino Real/San Carlos Avenue-Caltrain Station

Signalized

Direction	Movement	Volume (veh/hr)			GEH	Total Delay (sec/veh)		
		Demand	Served	% Served		Average	Std. Dev.	LOS
NB	Left Turn	90	88	98.0%	0.2	50.5	4.4	D
	Through	650	649	99.8%	0.1	17.0	0.9	B
	Right Turn	20	21	106.0%	0.3	15.2	3.0	B
	Subtotal	760	758	99.7%	0.1	20.8	0.9	C
SB	Left Turn	20	21	104.0%	0.2	48.5	3.8	D
	Through	870	864	99.4%	0.2	20.0	1.1	B
	Right Turn	280	282	100.7%	0.1	8.9	0.8	A
	Subtotal	1170	1167	99.8%	0.1	17.9	0.9	B
EB	Left Turn	500	512	102.4%	0.5	25.8	1.4	C
	Through	40	48	120.3%	1.2	29.7	3.6	C
	Right Turn	220	226	102.9%	0.4	22.5	1.3	C
	Subtotal	760	787	103.5%	1.0	25.1	1.0	C
WB	Left Turn	40	38	94.8%	0.3	65.7	10.5	E
	Through	40	38	95.3%	0.3	56.0	8.3	E
	Right Turn	40	40	98.8%	0.1	23.3	7.3	C
	Subtotal	120	116	96.3%	0.4	48.1	8.8	D
Total		2810	2827	100.6%	0.3	21.9	0.6	C

SimTraffic Post-Processor
Average Results from 20 Runs
Volume and Delay by Movement

Caltrain Electrification
2020 Plus Project Conditions
AM Peak Hour

Intersection California/Broadway

Unsignalized

Direction	Movement	Volume (veh/hr)			GEH	Total Delay (sec/veh)		
		Demand	Served	% Served		Average	Std. Dev.	LOS
NB	Left Turn	20	11	55.5%	2.3	728.9	262.1	F
	Through	30	21	69.0%	1.8	688.3	228.4	F
	Right Turn	90	62	68.8%	3.2	685.5	227.1	F
	Subtotal	140	94	66.9%	4.3	690.8	230.8	F
SB	Left Turn	30	27	89.3%	0.6	218.0	226.2	F
	Through	20	18	91.0%	0.4	237.7	240.2	F
	Right Turn	20	23	116.5%	0.7	197.6	273.6	F
	Subtotal	70	68	97.6%	0.2	215.2	244.3	F
EB	Left Turn	30	23	76.7%	1.4	69.4	13.9	F
	Through	480	399	83.1%	3.9	69.3	11.2	F
	Right Turn	70	50	71.6%	2.6	63.4	17.7	F
	Subtotal	580	472	81.3%	4.7	68.7	11.5	F
WB	Left Turn	70	69	98.1%	0.2	20.3	2.8	C
	Through	260	261	100.5%	0.1	9.4	1.3	A
	Right Turn	30	28	92.7%	0.4	0.6	0.3	A
	Subtotal	360	358	99.4%	0.1	10.8	1.3	B
Total		1150	992	86.2%	4.8	116.3	31.4	F

Intersection Arguello Street/Brewster Ave

Signalized

Direction	Movement	Volume (veh/hr)			GEH	Total Delay (sec/veh)		
		Demand	Served	% Served		Average	Std. Dev.	LOS
NB	Left Turn	20	17	85.0%	0.7	41.3	15.2	D
	Through	110	109	98.9%	0.1	25.4	4.1	C
	Right Turn	20	17	86.0%	0.6	4.5	0.9	A
	Subtotal	150	143	95.3%	0.6	24.7	2.2	C
SB	Left Turn	40	36	91.0%	0.6	61.8	10.8	E
	Through	140	145	103.4%	0.4	46.3	11.9	D
	Right Turn	140	144	102.6%	0.3	35.7	13.6	D
	Subtotal	320	325	101.5%	0.3	43.2	11.7	D
EB	Left Turn	80	27	34.0%	7.2	66.3	84.1	E
	Through	500	169	33.8%	18.1	100.9	54.5	F
	Right Turn	50	16	32.4%	5.9	75.9	194.9	E
	Subtotal	630	213	33.7%	20.3	94.5	59.1	F
WB	Left Turn	30	26	86.3%	0.8	34.7	8.7	C
	Through	140	132	94.3%	0.7	39.2	6.5	D
	Right Turn	20	20	101.0%	0.0	22.5	7.3	C
	Subtotal	190	178	93.7%	0.9	36.6	6.2	D
Total		1290	859	66.6%	13.2	46.6	13.3	D

Intersection

El Camino Real/Broadway

Signalized

Direction	Movement	Volume (veh/hr)			GEH	Total Delay (sec/veh)		
		Demand	Served	% Served		Average	Std. Dev.	LOS
NB	Left Turn	160	166	104.0%	0.5	66.3	14.3	E
	Through	1090	1101	101.0%	0.3	36.2	5.0	D
	Right Turn	80	80	99.8%	0.0	55.7	23.5	E
	Subtotal	1330	1348	101.3%	0.5	41.1	4.6	D
SB	Left Turn	110	105	95.4%	0.5	159.7	91.8	F
	Through	1000	1005	100.5%	0.2	31.3	2.8	C
	Right Turn	10	9	93.0%	0.2	18.4	5.3	B
	Subtotal	1120	1119	99.9%	0.0	43.7	8.4	D
EB	Left Turn	10	6	57.0%	1.5	175.4	68.4	F
	Through	440	286	65.1%	8.1	181.9	28.0	F
	Right Turn	290	189	65.0%	6.6	148.7	16.0	F
	Subtotal	740	481	65.0%	10.5	168.8	23.6	F
WB	Left Turn	30	26	87.3%	0.7	37.7	8.9	D
	Through	220	219	99.7%	0.0	23.8	3.0	C
	Right Turn	70	68	97.1%	0.2	18.4	2.5	B
	Subtotal	320	314	98.0%	0.4	23.9	2.8	C
Total		3510	3261	92.9%	4.3	58.9	4.3	E

Intersection

Arguello St/Broadway

Signalized

Direction	Movement	Volume (veh/hr)			GEH	Total Delay (sec/veh)		
		Demand	Served	% Served		Average	Std. Dev.	LOS
NB	Left Turn	50	48	96.0%	0.3	36.4	9.9	D
	Through	80	80	99.6%	0.0	28.9	5.0	C
	Right Turn	20	19	96.5%	0.2	21.7	7.4	C
	Subtotal	150	147	98.0%	0.2	30.4	6.1	C
SB	Left Turn	50	42	84.6%	1.1	45.2	6.4	D
	Through	130	115	88.3%	1.4	33.7	5.0	C
	Right Turn	40	36	89.3%	0.7	24.2	5.5	C
	Subtotal	220	193	87.6%	1.9	34.3	4.8	C
EB	Left Turn	40	31	77.0%	1.5	16.9	1.9	B
	Through	440	326	74.0%	5.8	8.0	0.8	A
	Right Turn	120	93	77.5%	2.6	1.7	0.4	A
	Subtotal	600	450	74.9%	6.6	7.3	0.7	A
WB	Left Turn	30	31	102.0%	0.1	88.9	33.3	F
	Through	270	274	101.6%	0.3	78.3	30.4	E
	Right Turn	30	30	101.0%	0.1	4.9	2.3	A
	Subtotal	330	335	101.6%	0.3	72.4	27.2	E
Total		1300	1125	86.5%	5.0	34.4	9.7	C

SimTraffic Post-Processor
Average Results from 20 Runs
Volume and Delay by Movement

Caltrain Electrification
2020 Plus Project Conditions
AM Peak Hour

Intersection

El Camino Real/James

Signalized

Direction	Movement	Volume (veh/hr)			GEH	Total Delay (sec/veh)		
		Demand	Served	% Served		Average	Std. Dev.	LOS
NB	Left Turn	179	171	95.3%	0.6	62.8	9.7	E
	Through	1200	1146	95.5%	1.6	24.4	2.7	C
	Right Turn	63	67	106.5%	0.5	10.2	0.4	B
	Subtotal	1442	1384	96.0%	1.6	28.5	2.9	C
SB	Left Turn	95	83	87.7%	1.2	53.9	6.3	D
	Through	1179	1037	87.9%	4.3	31.4	5.1	C
	Right Turn	116	103	89.1%	1.2	15.9	3.8	B
	Subtotal	1390	1224	88.0%	4.6	31.6	4.9	C
EB	Left Turn	147	141	95.6%	0.5	36.4	2.5	D
	Through	95	94	99.2%	0.1	17.6	1.1	B
	Right Turn	179	165	92.2%	1.1	17.2	1.5	B
	Subtotal	421	400	94.9%	1.1	24.1	1.0	C
WB	Left Turn	84	69	82.5%	1.7	23.9	2.6	C
	Through	147	121	82.0%	2.3	25.7	3.8	C
	Right Turn	53	45	85.7%	1.1	22.9	5.0	C
	Subtotal	284	235	82.9%	3.0	24.6	2.9	C
Total		3537	3242	91.7%	5.1	28.8	2.5	C

Intersection

El Camino Real/Atherton Avenue-Fair Oaks Lane

Signalized

Direction	Movement	Volume (veh/hr)			GEH	Total Delay (sec/veh)		
		Demand	Served	% Served		Average	Std. Dev.	LOS
NB	Left Turn	80	79	98.4%	0.1	53.9	11.8	D
	Through	790	818	103.5%	1.0	18.9	0.9	B
	Right Turn	30	31	102.7%	0.1	19.9	4.5	B
	Subtotal	900	927	103.0%	0.9	22.0	1.6	C
SB	Left Turn	70	72	102.3%	0.2	51.8	5.4	D
	Through	1720	1704	99.1%	0.4	48.0	8.2	D
	Right Turn	180	175	97.4%	0.4	58.0	9.8	E
	Subtotal	1970	1951	99.0%	0.4	49.1	8.2	D
EB	Left Turn	120	110	91.3%	1.0	37.8	3.9	D
	Through	80	79	98.3%	0.2	34.8	4.4	C
	Right Turn	150	146	97.5%	0.3	22.8	2.9	C
	Subtotal	350	335	95.6%	0.8	30.5	3.3	C
WB	Left Turn	80	74	91.9%	0.7	63.6	14.2	E
	Through	130	133	101.9%	0.2	59.4	12.4	E
	Right Turn	70	77	109.4%	0.8	34.1	9.8	C
	Subtotal	280	283	100.9%	0.2	53.7	12.1	D
Total		3500	3495	99.9%	0.1	40.5	4.4	D

Intersection

El Camino Real/Watkins Avenue

Unsignalized

Direction	Movement	Volume (veh/hr)			GEH	Total Delay (sec/veh)		
		Demand	Served	% Served		Average	Std. Dev.	LOS
NB	Left Turn							
	Through	830	846	101.9%	0.5	0.9	0.1	A
	Right Turn	70	68	97.6%	0.2	1.4	0.3	A
	Subtotal	900	914	101.5%	0.5	1.0	0.1	A
SB	Left Turn	70	62	88.7%	1.0	10.4	0.9	B
	Through	1880	1867	99.3%	0.3	4.9	0.1	A
	Right Turn							
	Subtotal	1950	1929	98.9%	0.5	5.1	0.1	A
EB	Left Turn							
	Through							
	Right Turn							
	Subtotal							
WB	Left Turn	70	69	97.9%	0.2	52.8	10.0	F
	Through							
	Right Turn	70	74	106.0%	0.5	34.3	12.3	D
	Subtotal	140	143	101.9%	0.2	43.1	10.7	E
Total		2990	2986	99.8%	0.1	5.7	0.6	A

Intersection

El Camino Real/Glenwood

Signalized

Direction	Movement	Volume (veh/hr)			GEH	Total Delay (sec/veh)		
		Demand	Served	% Served		Average	Std. Dev.	LOS
NB	Left Turn	70	65	93.3%	0.6	56.5	5.7	E
	Through	1050	939	89.4%	3.5	37.7	1.4	D
	Right Turn	40	39	96.3%	0.2	25.5	4.9	C
	Subtotal	1160	1042	89.9%	3.5	38.5	1.5	D
SB	Left Turn	70	58	83.4%	1.4	175.9	15.7	F
	Through	1380	1174	85.1%	5.8	174.6	12.0	F
	Right Turn	470	402	85.6%	3.2	54.8	4.1	D
	Subtotal	1920	1634	85.1%	6.8	145.2	10.3	F
EB	Left Turn	260	256	98.5%	0.2	73.1	36.6	E
	Through	150	141	93.9%	0.8	77.1	34.0	E
	Right Turn	110	114	103.6%	0.4	41.6	29.9	D
	Subtotal	520	511	98.3%	0.4	67.1	34.3	E
WB	Left Turn	80	76	94.6%	0.5	57.8	11.2	E
	Through	190	191	100.7%	0.1	60.8	12.2	E
	Right Turn	20	19	97.0%	0.1	51.6	18.4	D
	Subtotal	290	287	98.8%	0.2	59.4	12.0	E
Total		3890	3474	89.3%	6.9	94.6	5.6	F

Intersection

El Camino Real/Oak Grove

Signalized

Direction	Movement	Volume (veh/hr)			GEH	Total Delay (sec/veh)		
		Demand	Served	% Served		Average	Std. Dev.	LOS
NB	Left Turn	90	77	85.1%	1.5	34.0	9.4	C
	Through	1050	935	89.0%	3.7	4.0	0.4	A
	Right Turn	80	67	83.1%	1.6	2.0	0.2	A
	Subtotal	1220	1078	88.3%	4.2	6.0	0.7	A
SB	Left Turn	110	95	86.7%	1.4	142.2	6.0	F
	Through	1390	1202	86.5%	5.2	123.7	5.4	F
	Right Turn	70	59	84.9%	1.3	109.2	7.0	F
	Subtotal	1570	1357	86.4%	5.6	124.4	5.3	F
EB	Left Turn	70	62	88.1%	1.0	66.2	6.8	E
	Through	180	166	92.3%	1.0	49.1	4.1	D
	Right Turn	50	51	101.6%	0.1	29.7	3.3	C
	Subtotal	300	279	92.9%	1.3	49.4	3.5	D
WB	Left Turn	110	111	100.7%	0.1	52.4	5.2	D
	Through	200	205	102.7%	0.4	43.9	4.2	D
	Right Turn	40	41	102.8%	0.2	13.4	2.6	B
	Subtotal	350	357	102.1%	0.4	43.0	3.6	D
Total		3440	3070	89.3%	6.5	66.6	2.8	E

Intersection El Camino Real/Santa Cruz Ave

Signalized

Direction	Movement	Volume (veh/hr)			GEH	Total Delay (sec/veh)		
		Demand	Served	% Served		Average	Std. Dev.	LOS
NB	Left Turn							
	Through	1090	963	88.3%	4.0	4.8	0.8	A
	Right Turn	140	121	86.4%	1.7	6.0	6.8	A
	Subtotal	1230	1083	88.1%	4.3	4.9	1.5	A
SB	Left Turn							
	Through	1460	1278	87.5%	4.9	27.4	1.8	C
	Right Turn	90	75	83.7%	1.6	18.4	1.8	B
	Subtotal	1550	1353	87.3%	5.2	26.9	1.7	C
EB	Left Turn	100	103	102.9%	0.3	38.4	3.5	D
	Through	80	80	99.8%	0.0	38.6	8.5	D
	Right Turn	170	174	102.1%	0.3	55.0	14.6	D
	Subtotal	350	356	101.8%	0.3	46.7	7.4	D
WB	Left Turn	70	72	102.6%	0.2	40.4	4.5	D
	Through	70	72	102.9%	0.2	41.3	4.3	D
	Right Turn	30	36	120.7%	1.1	25.4	4.4	C
	Subtotal	170	180	105.9%	0.8	37.7	3.0	D
Total		3300	2973	90.1%	5.8	21.9	1.8	C

Intersection Merrill St/Santa Cruz Ave

Unsignalized

Direction	Movement	Volume (veh/hr)			GEH	Total Delay (sec/veh)		
		Demand	Served	% Served		Average	Std. Dev.	LOS
NB	Left Turn	70	75	106.4%	0.5	7.3	1.1	A
	Through	20	24	119.5%	0.8	7.1	1.2	A
	Right Turn	10	10	97.0%	0.1	6.2	2.8	A
	Subtotal	100	108	108.1%	0.8	7.2	1.0	A
SB	Left Turn	20	24	119.0%	0.8	9.3	5.9	A
	Through	30	32	108.0%	0.4	12.2	9.3	B
	Right Turn	80	83	103.5%	0.3	7.8	5.8	A
	Subtotal	130	139	106.9%	0.8	9.0	6.5	A
EB	Left Turn	80	75	93.5%	0.6	12.4	16.4	B
	Through	20	23	112.5%	0.5	10.8	12.1	B
	Right Turn	120	105	87.1%	1.5	10.5	14.9	B
	Subtotal	220	202	91.7%	1.3	11.2	15.0	B
WB	Left Turn	10	10	98.0%	0.1	5.5	6.7	A
	Through	20	22	109.0%	0.4	4.4	2.0	A
	Right Turn	10	10	96.0%	0.1	3.6	1.5	A
	Subtotal	40	41	103.0%	0.2	4.4	2.7	A
Total		490	490	100.0%	0.0	9.1	8.2	A

Intersection Ravenswood Ave/Laurel St

Signalized

Direction	Movement	Volume (veh/hr)			GEH	Total Delay (sec/veh)		
		Demand	Served	% Served		Average	Std. Dev.	LOS
NB	Left Turn	170	174	102.4%	0.3	37.1	4.2	D
	Through	70	75	107.3%	0.6	22.8	4.3	C
	Right Turn	30	31	104.7%	0.3	19.1	3.9	B
	Subtotal	270	281	103.9%	0.6	31.3	3.9	C
SB	Left Turn	170	167	98.5%	0.2	86.1	38.2	F
	Through	170	168	98.6%	0.2	83.8	39.9	F
	Right Turn	80	83	103.9%	0.3	81.3	44.0	F
	Subtotal	420	418	99.6%	0.1	84.2	39.9	F
EB	Left Turn	40	34	86.0%	0.9	41.6	5.5	D
	Through	770	718	93.2%	1.9	27.4	3.8	C
	Right Turn	80	75	93.5%	0.6	22.4	4.7	C
	Subtotal	890	827	92.9%	2.1	27.5	3.7	C
WB	Left Turn	20	19	95.5%	0.2	59.8	10.4	E
	Through	570	576	101.0%	0.2	18.3	2.9	B
	Right Turn	20	21	105.5%	0.2	15.7	4.9	B
	Subtotal	610	616	101.0%	0.2	19.6	2.9	B
Total		2190	2142	97.8%	1.0	37.0	9.2	D

SimTraffic Post-Processor
Average Results from 20 Runs
Volume and Delay by Movement

Caltrain Electrification
2020 Plus Project Conditions
AM Peak Hour

Intersection

High Street/University Ave

Signalized

Direction	Movement	Volume (veh/hr)			GEH	Total Delay (sec/veh)		
		Demand	Served	% Served		Average	Std. Dev.	LOS
NB	Left Turn							
	Through							
	Right Turn							
	Subtotal							
SB	Left Turn	20	21	103.5%	0.2	21.7	7.5	C
	Through	40	45	111.5%	0.7	10.6	2.1	B
	Right Turn	250	261	104.2%	0.7	14.2	1.6	B
	Subtotal	310	326	105.1%	0.9	14.2	1.4	B
EB	Left Turn							
	Through	590	585	99.1%	0.2	10.4	0.9	B
	Right Turn	320	309	96.5%	0.6	4.0	0.3	A
	Subtotal	910	894	98.2%	0.5	8.2	0.6	A
WB	Left Turn	40	36	89.0%	0.7	29.1	2.1	C
	Through	610	597	97.9%	0.5	18.0	1.4	B
	Right Turn							
	Subtotal	650	633	97.3%	0.7	18.6	1.3	B
Total		1870	1852	99.0%	0.4	12.8	0.4	B

Intersection

Showers Drive/Pacchetti Way

Signalized

Direction	Movement	Volume (veh/hr)			GEH	Total Delay (sec/veh)		
		Demand	Served	% Served		Average	Std. Dev.	LOS
NB	Left Turn	20	17	83.0%	0.8	22.0	2.5	C
	Through	30	28	93.0%	0.4	1.5	0.7	A
	Right Turn							
	Subtotal	50	45	89.0%	0.8	9.2	1.1	A
SB	Left Turn							
	Through	80	82	102.1%	0.2	3.2	0.4	A
	Right Turn	40	40	100.3%	0.0	1.3	0.9	A
	Subtotal	120	122	101.5%	0.2	2.6	0.5	A
EB	Left Turn	10	9	88.0%	0.4	14.4	2.0	B
	Through							
	Right Turn	10	8	84.0%	0.5	3.0	0.8	A
	Subtotal	20	17	86.0%	0.6	8.9	1.4	A
WB	Left Turn							
	Through							
	Right Turn							
	Subtotal							
Total		190	184	96.6%	0.5	4.8	0.5	A

Intersection Hope Street/Evelyn Ave

Signalized

Direction	Movement	Volume (veh/hr)			GEH	Total Delay (sec/veh)		
		Demand	Served	% Served		Average	Std. Dev.	LOS
NB	Left Turn	40	38	95.5%	0.3	19.6	2.5	B
	Through							
	Right Turn	80	84	105.4%	0.5	5.7	0.6	A
	Subtotal	120	123	102.1%	0.2	10.0	1.0	A
SB	Left Turn							
	Through							
	Right Turn							
	Subtotal							
EB	Left Turn							
	Through	40	38	95.5%	0.3	2.3	0.9	A
	Right Turn	40	42	105.5%	0.3	1.0	0.2	A
	Subtotal	80	80	100.5%	0.0	1.6	0.5	A
WB	Left Turn	60	61	102.0%	0.2	2.2	0.7	A
	Through	340	346	101.9%	0.3	2.4	0.2	A
	Right Turn							
	Subtotal	400	408	101.9%	0.4	2.4	0.2	A
Total		600	611	101.8%	0.4	3.8	0.3	A

Intersection Castro Street/Villa Street

Signalized

Direction	Movement	Volume (veh/hr)			GEH	Total Delay (sec/veh)		
		Demand	Served	% Served		Average	Std. Dev.	LOS
NB	Left Turn	20	20	101.0%	0.0	18.8	2.4	B
	Through	180	185	102.6%	0.3	11.6	1.2	B
	Right Turn	50	48	95.8%	0.3	6.7	1.2	A
	Subtotal	250	253	101.1%	0.2	11.3	1.0	B
SB	Left Turn	170	172	101.0%	0.1	12.0	1.6	B
	Through	210	215	102.4%	0.3	6.9	0.9	A
	Right Turn	10	10	103.0%	0.1	3.6	1.4	A
	Subtotal	390	397	101.8%	0.4	9.0	0.7	A
EB	Left Turn	50	48	96.4%	0.3	23.9	4.8	C
	Through	180	188	104.4%	0.6	18.4	3.7	B
	Right Turn	10	10	98.0%	0.1	14.4	4.7	B
	Subtotal	240	246	102.5%	0.4	19.3	3.9	B
WB	Left Turn	50	51	101.2%	0.1	24.9	2.8	C
	Through	200	206	102.9%	0.4	21.5	1.6	C
	Right Turn	50	51	102.6%	0.2	15.0	2.4	B
	Subtotal	300	308	102.5%	0.4	20.9	1.6	C
Total		1180	1203	102.0%	0.7	14.7	1.0	B

SimTraffic Post-Processor
Average Results from 20 Runs
Volume and Delay by Movement

Caltrain Electrification
2020 Plus Project Conditions
AM Peak Hour

Intersection

Frances St/Evelyn Ave

Signalized

Direction	Movement	Volume (veh/hr)			GEH	Total Delay (sec/veh)		
		Demand	Served	% Served		Average	Std. Dev.	LOS
NB	Left Turn	20	18	91.0%	0.4	20.4	2.9	C
	Through	40	39	98.0%	0.1	15.6	2.5	B
	Right Turn	10	10	101.0%	0.0	6.4	2.8	A
	Subtotal	70	68	96.4%	0.3	15.6	1.9	B
SB	Left Turn	160	165	103.4%	0.4	34.6	10.3	C
	Through	50	52	103.6%	0.3	32.5	9.8	C
	Right Turn	140	137	97.6%	0.3	27.1	8.2	C
	Subtotal	350	354	101.1%	0.2	31.4	9.4	C
EB	Left Turn	90	84	93.4%	0.6	125.6	43.7	F
	Through	200	205	102.3%	0.3	16.6	2.3	B
	Right Turn	30	35	116.7%	0.9	10.7	3.8	B
	Subtotal	320	324	101.2%	0.2	44.9	14.1	D
WB	Left Turn	40	37	93.5%	0.4	59.4	23.9	E
	Through	520	540	103.9%	0.9	29.9	5.9	C
	Right Turn	220	219	99.3%	0.1	18.5	4.6	B
	Subtotal	780	796	102.1%	0.6	28.1	5.7	C
Total		1520	1541	101.4%	0.5	31.9	3.4	C

Intersection Lawrence Expressway/Kifer Road

Signalized

Direction	Movement	Volume (veh/hr)			GEH	Total Delay (sec/veh)		
		Demand	Served	% Served		Average	Std. Dev.	LOS
NB	Left Turn	260	200	76.8%	4.0	171.1	6.0	F
	Through	4650	3539	76.1%	17.4	174.5	6.9	F
	Right Turn	560	440	78.6%	5.4	192.0	7.9	F
	Subtotal	5470	4179	76.4%	18.6	176.1	6.8	F
SB	Left Turn	230	233	101.3%	0.2	103.1	24.7	F
	Through	1440	1430	99.3%	0.3	19.2	1.1	B
	Right Turn	400	387	96.8%	0.7	13.0	1.8	B
	Subtotal	2070	2050	99.0%	0.4	27.7	3.9	C
EB	Left Turn	120	117	97.4%	0.3	62.2	5.5	E
	Through	150	153	102.1%	0.3	49.4	3.4	D
	Right Turn	240	243	101.3%	0.2	2.1	0.2	A
	Subtotal	510	513	100.6%	0.1	29.9	2.3	C
WB	Left Turn	80	76	94.6%	0.5	61.8	5.8	E
	Through	200	204	102.0%	0.3	49.9	2.7	D
	Right Turn	160	167	104.2%	0.5	6.1	2.3	A
	Subtotal	440	446	101.5%	0.3	35.6	2.4	D
Total		8490	7188	84.7%	14.7	114.6	4.3	F

Intersection Lawrence Expressway/Reed Ave-Monroe St

Signalized

Direction	Movement	Volume (veh/hr)			GEH	Total Delay (sec/veh)		
		Demand	Served	% Served		Average	Std. Dev.	LOS
NB	Left Turn	170	138	81.2%	2.6	133.4	8.5	F
	Through	4730	3688	78.0%	16.1	115.7	7.6	F
	Right Turn	110	83	75.5%	2.7	93.9	5.7	F
	Subtotal	5010	3909	78.0%	16.5	115.8	7.4	F
SB	Left Turn	100	102	101.7%	0.2	69.3	7.1	E
	Through	1480	1480	100.0%	0.0	34.3	4.2	C
	Right Turn	180	176	97.9%	0.3	12.0	1.2	B
	Subtotal	1760	1758	99.9%	0.1	34.1	3.5	C
EB	Left Turn	430	315	73.2%	6.0	591.7	211.4	F
	Through	340	307	90.3%	1.8	82.6	26.1	F
	Right Turn	240	227	94.5%	0.9	25.0	18.5	C
	Subtotal	1010	849	84.0%	5.3	253.9	89.0	F
WB	Left Turn	200	184	92.0%	1.2	103.4	124.5	F
	Through	240	209	87.0%	2.1	85.7	105.0	F
	Right Turn	310	280	90.3%	1.8	182.8	400.8	F
	Subtotal	750	673	89.7%	2.9	125.9	218.3	F
Total		8530	7188	84.3%	15.1	107.4	5.8	F

SimTraffic Post-Processor
Average Results from 20 Runs
Volume and Delay by Movement

Caltrain Electrification
2020 Plus Project Conditions
AM Peak Hour

Intersection

El Camino Real/Railroad Avenue

Signalized

Direction	Movement	Volume (veh/hr)			GEH	Total Delay (sec/veh)		
		Demand	Served	% Served		Average	Std. Dev.	LOS
NB	Left Turn	210	207	98.7%	0.2	61.8	14.1	E
	Through	1090	1110	101.9%	0.6	14.4	0.4	B
	Right Turn	80	81	101.1%	0.1	14.7	0.9	B
	Subtotal	1380	1399	101.3%	0.5	21.5	2.5	C
SB	Left Turn	80	82	102.8%	0.2	40.3	4.9	D
	Through	400	410	102.5%	0.5	14.4	0.9	B
	Right Turn	100	102	101.7%	0.2	11.6	1.3	B
	Subtotal	580	594	102.4%	0.6	17.5	1.1	B
EB	Left Turn	10	10	98.0%	0.1	26.6	6.6	C
	Through	10	10	97.0%	0.1	18.8	3.9	B
	Right Turn	30	28	93.0%	0.4	7.8	0.9	A
	Subtotal	50	47	94.8%	0.4	14.0	2.9	B
WB	Left Turn	70	69	98.9%	0.1	29.4	2.9	C
	Through	30	30	101.0%	0.1	17.5	2.5	B
	Right Turn	60	64	107.0%	0.5	7.5	1.3	A
	Subtotal	160	164	102.3%	0.3	18.7	1.5	B
Total		2170	2203	101.5%	0.7	20.1	1.4	C

Intersection Santa Clara Street/Cahill Street

Signalized

Direction	Movement	Volume (veh/hr)			GEH	Total Delay (sec/veh)		
		Demand	Served	% Served		Average	Std. Dev.	LOS
NB	Left Turn	100	99	98.6%	0.1	28.7	2.9	C
	Through	10	17	166.0%	1.8	18.6	4.3	B
	Right Turn	140	141	100.9%	0.1	9.8	0.7	A
	Subtotal	250	257	102.6%	0.4	17.6	1.5	B
SB	Left Turn	10	9	91.0%	0.3	41.0	14.7	D
	Through	10	10	95.0%	0.2	36.2	6.6	D
	Right Turn	10	11	106.0%	0.2	14.1	8.4	B
	Subtotal	30	29	97.3%	0.1	28.8	4.9	C
EB	Left Turn							
	Through	530	541	102.0%	0.5	32.9	3.9	C
	Right Turn	110	108	98.5%	0.2	34.8	5.2	C
	Subtotal	640	649	101.4%	0.4	33.2	4.1	C
WB	Left Turn	380	359	94.4%	1.1	46.6	7.3	D
	Through	1210	1178	97.4%	0.9	11.4	2.7	B
	Right Turn	20	22	108.5%	0.4	11.1	11.3	B
	Subtotal	1610	1559	96.8%	1.3	19.6	3.6	B
Total		2530	2494	98.6%	0.7	23.0	3.0	C

Intersection San Fernando Street/Montgomery Street

Signalized

Direction	Movement	Volume (veh/hr)			GEH	Total Delay (sec/veh)		
		Demand	Served	% Served		Average	Std. Dev.	LOS
NB	Left Turn							
	Through							
	Right Turn							
	Subtotal							
SB	Left Turn	80	81	101.1%	0.1	48.1	13.2	D
	Through	570	566	99.3%	0.2	45.0	11.9	D
	Right Turn	10	7	74.0%	0.9	39.5	18.0	D
	Subtotal	660	654	99.2%	0.2	45.3	12.0	D
EB	Left Turn							
	Through	140	149	106.1%	0.7	8.0	0.9	A
	Right Turn	180	179	99.6%	0.1	6.9	0.9	A
	Subtotal	320	328	102.4%	0.4	7.4	0.8	A
WB	Left Turn	310	306	98.7%	0.2	24.5	7.2	C
	Through	360	380	105.5%	1.0	23.0	8.6	C
	Right Turn							
	Subtotal	670	686	102.4%	0.6	23.7	7.7	C
Total		1650	1668	101.1%	0.4	29.0	7.4	C

SimTraffic Post-Processor
Average Results from 20 Runs
Volume and Delay by Movement

Caltrain Electrification
2020 Plus Project Conditions
AM Peak Hour

Intersection

Lick Avenue-Shadow Run Drive/Alma Avenue

Signalized

Direction	Movement	Volume (veh/hr)			GEH	Total Delay (sec/veh)		
		Demand	Served	% Served		Average	Std. Dev.	LOS
NB	Left Turn	40	40	100.3%	0.0	31.8	4.3	C
	Through	70	70	99.7%	0.0	27.3	2.8	C
	Right Turn	20	23	112.5%	0.5	12.6	3.6	B
	Subtotal	130	132	101.8%	0.2	26.1	2.7	C
SB	Left Turn	90	92	102.4%	0.2	38.1	2.1	D
	Through	10	10	100.0%	0.0	25.4	5.8	C
	Right Turn	60	59	98.3%	0.1	4.8	0.7	A
	Subtotal	160	161	100.8%	0.1	25.1	1.6	C
EB	Left Turn	100	99	98.5%	0.2	35.2	2.8	D
	Through	460	466	101.2%	0.3	15.5	0.6	B
	Right Turn	20	19	96.0%	0.2	12.7	3.0	B
	Subtotal	580	583	100.6%	0.1	18.8	0.7	B
WB	Left Turn	60	61	102.2%	0.2	53.9	6.0	D
	Through	640	633	98.9%	0.3	34.2	3.6	C
	Right Turn	550	547	99.4%	0.1	42.2	5.2	D
	Subtotal	1250	1241	99.3%	0.3	38.7	4.2	D
Total		2120	2118	99.9%	0.0	31.4	2.5	C

Intersection 7th Street/Mission Bay

Signalized

Direction	Movement	Volume (veh/hr)			GEH	Total Delay (sec/veh)		
		Demand	Served	% Served		Average	Std. Dev.	LOS
NB	Left Turn	10	10	99.0%	0.0	21.9	3.9	C
	Through	810	814	100.4%	0.1	11.5	1.0	B
	Right Turn	50	51	101.0%	0.1	14.5	3.8	B
	Subtotal	870	874	100.4%	0.1	11.8	0.8	B
SB	Left Turn	40	37	93.5%	0.4	34.5	6.1	C
	Through	290	280	96.6%	0.6	6.8	0.5	A
	Right Turn	10	9	87.0%	0.4	3.9	2.1	A
	Subtotal	340	326	96.0%	0.8	9.9	1.1	A
EB	Left Turn							
	Through							
	Right Turn							
	Subtotal							
WB	Left Turn	30	30	99.3%	0.0	3.7	1.9	A
	Through							
	Right Turn	70	73	103.6%	0.3	0.8	0.2	A
	Subtotal	100	102	102.3%	0.2	1.7	0.6	A
Total		1310	1303	99.4%	0.2	10.5	0.7	B

Intersection Berry Street/Mission Bay

Signalized

Direction	Movement	Volume (veh/hr)			GEH	Total Delay (sec/veh)		
		Demand	Served	% Served		Average	Std. Dev.	LOS
NB	Left Turn							
	Through							
	Right Turn							
	Subtotal							
SB	Left Turn							
	Through							
	Right Turn	100	103	102.7%	0.3	2.1	0.3	A
	Subtotal	100	103	102.7%	0.3	2.1	0.3	A
EB	Left Turn	90	89	98.6%	0.1	0.8	0.6	A
	Through							
	Right Turn							
	Subtotal	90	89	98.6%	0.1	0.8	0.6	A
WB	Left Turn							
	Through							
	Right Turn							
	Subtotal							
Total		190	191	100.7%	0.1	1.5	0.2	A

SimTraffic Post-Processor
Average Results from 20 Runs
Volume and Delay by Movement

Caltrain Electrification
2020 Plus Project Conditions
AM Peak Hour

Intersection Main Street/Maple Street

Unsignalized

Direction	Movement	Volume (veh/hr)			GEH	Total Delay (sec/veh)		
		Demand	Served	% Served		Average	Std. Dev.	LOS
NB	Left Turn							
	Through	460	470	102.3%	0.5	6.7	0.6	A
	Right Turn							
	Subtotal	460	470	102.3%	0.5	6.7	0.6	A
SB	Left Turn							
	Through	320	309	96.7%	0.6	11.0	0.9	B
	Right Turn							
	Subtotal	320	309	96.7%	0.6	11.0	0.9	B
EB	Left Turn							
	Through							
	Right Turn							
	Subtotal							
WB	Left Turn							
	Through							
	Right Turn	20	18	91.5%	0.4	35.4	17.2	E
	Subtotal	20	18	91.5%	0.4	35.4	17.2	E
Total		800	798	99.8%	0.1	9.0	0.5	A

Intersection Main Street/Beech Street

Unsignalized

Direction	Movement	Volume (veh/hr)			GEH	Total Delay (sec/veh)		
		Demand	Served	% Served		Average	Std. Dev.	LOS
NB	Left Turn	70	70	100.0%	0.0	5.6	1.2	A
	Through	280	290	103.7%	0.6	2.0	0.6	A
	Right Turn							
	Subtotal	350	360	102.9%	0.5	2.7	0.7	A
SB	Left Turn							
	Through	200	196	97.9%	0.3	2.5	0.3	A
	Right Turn	160	158	98.5%	0.2	1.2	0.2	A
	Subtotal	360	353	98.1%	0.4	1.9	0.2	A
EB	Left Turn	30	30	98.7%	0.1	12.5	2.1	B
	Through							
	Right Turn	60	62	103.5%	0.3	5.7	1.3	A
	Subtotal	90	92	101.9%	0.2	7.9	1.4	A
WB	Left Turn							
	Through							
	Right Turn							
	Subtotal							
Total		800	805	100.7%	0.2	3.0	0.5	A

Intersection Main Street/Middlefield Road

Signalized

Direction	Movement	Volume (veh/hr)			GEH	Total Delay (sec/veh)		
		Demand	Served	% Served		Average	Std. Dev.	LOS
NB	Left Turn	60	59	98.2%	0.1	53.7	4.3	D
	Through	380	399	104.9%	0.9	29.0	0.6	C
	Right Turn	30	31	102.0%	0.1	9.8	6.6	A
	Subtotal	470	488	103.8%	0.8	30.8	0.6	C
SB	Left Turn	30	28	94.3%	0.3	44.9	5.9	D
	Through	250	239	95.6%	0.7	29.2	2.4	C
	Right Turn	50	49	97.6%	0.2	2.9	0.3	A
	Subtotal	330	316	95.8%	0.8	26.5	1.9	C
EB	Left Turn	60	62	103.5%	0.3	30.4	2.9	C
	Through	330	333	101.0%	0.2	30.1	2.0	C
	Right Turn	50	51	102.2%	0.2	22.0	4.4	C
	Subtotal	440	447	101.5%	0.3	29.2	2.3	C
WB	Left Turn	20	18	89.0%	0.5	4.8	2.8	A
	Through	110	105	95.1%	0.5	3.7	0.7	A
	Right Turn	70	69	98.9%	0.1	1.0	0.3	A
	Subtotal	200	192	95.8%	0.6	2.9	0.7	A
Total		1440	1442	100.2%	0.1	25.7	0.8	C

Intersection Fair Oaks Lane/Middlefield Road

Unsignalized

Direction	Movement	Volume (veh/hr)			GEH	Total Delay (sec/veh)		
		Demand	Served	% Served		Average	Std. Dev.	LOS
NB	Left Turn	20	21	103.0%	0.1	160.2	71.9	F
	Through	10	9	85.0%	0.5	185.8	103.4	F
	Right Turn	200	188	93.8%	0.9	95.1	61.1	F
	Subtotal	230	217	94.2%	0.9	104.7	63.0	F
SB	Left Turn	20	16	77.5%	1.1	644.9	128.6	F
	Through	70	56	80.6%	1.7	655.9	129.3	F
	Right Turn	50	43	85.8%	1.0	605.8	120.5	F
	Subtotal	140	115	82.0%	2.2	636.0	123.0	F
EB	Left Turn	10	8	82.0%	0.6	6.7	1.5	A
	Through	700	699	99.8%	0.1	4.8	0.2	A
	Right Turn	110	111	101.3%	0.1	3.7	0.3	A
	Subtotal	820	818	99.8%	0.1	4.6	0.2	A
WB	Left Turn	220	218	99.1%	0.1	23.7	4.2	C
	Through	440	450	102.4%	0.5	7.1	2.1	A
	Right Turn	20	17	87.0%	0.6	6.8	4.3	A
	Subtotal	680	686	100.9%	0.2	12.4	2.7	B
Total		1870	1836	98.2%	0.8	58.2	10.7	F

Intersection Watkins Avenue/Middlefield Road

Unsignalized

Direction	Movement	Volume (veh/hr)			GEH	Total Delay (sec/veh)		
		Demand	Served	% Served		Average	Std. Dev.	LOS
NB	Left Turn	70	73	104.6%	0.4	71.3	22.6	F
	Through							
	Right Turn	80	83	104.0%	0.4	30.3	12.7	D
	Subtotal	150	156	104.3%	0.5	49.5	17.4	E
SB	Left Turn							
	Through							
	Right Turn							
	Subtotal							
EB	Left Turn							
	Through	820	817	99.6%	0.1	4.9	0.3	A
	Right Turn	100	97	97.1%	0.3	4.2	0.2	A
	Subtotal	920	914	99.3%	0.2	4.9	0.3	A
WB	Left Turn	60	56	94.0%	0.5	17.4	3.5	C
	Through	610	612	100.4%	0.1	5.1	0.4	A
	Right Turn							
	Subtotal	670	669	99.8%	0.1	6.1	0.6	A
Total		1740	1739	99.9%	0.0	9.5	1.8	A

Intersection

Linden Avenue-Glenwood Avenue/Middlefield Road

Unsignalized

Direction	Movement	Volume (veh/hr)			GEH	Total Delay (sec/veh)		
		Demand	Served	% Served		Average	Std. Dev.	LOS
NB	Left Turn	70	68	97.4%	0.2	165.7	87.9	F
	Through	10	9	85.0%	0.5	132.4	55.7	F
	Right Turn	100	101	100.6%	0.1	89.3	67.8	F
	Subtotal	180	177	98.5%	0.2	120.9	73.6	F
SB	Left Turn	30	30	98.3%	0.1	93.0	27.2	F
	Through	10	9	85.0%	0.5	114.5	34.6	F
	Right Turn	40	42	105.5%	0.3	60.5	22.7	F
	Subtotal	80	80	100.3%	0.0	78.0	24.8	F
EB	Left Turn	50	46	92.6%	0.5	11.2	1.1	B
	Through	680	688	101.1%	0.3	8.9	0.5	A
	Right Turn	170	165	97.1%	0.4	7.5	0.5	A
	Subtotal	900	899	99.9%	0.0	8.8	0.5	A
WB	Left Turn	90	87	96.6%	0.3	18.0	2.7	C
	Through	560	554	98.9%	0.3	3.0	0.3	A
	Right Turn	10	11	113.0%	0.4	2.0	0.9	A
	Subtotal	660	652	98.8%	0.3	5.0	0.6	A
Total		1820	1808	99.4%	0.3	21.2	7.2	C

Intersection California Street/Rengstorff Avenue

Signalized

Direction	Movement	Volume (veh/hr)			GEH	Total Delay (sec/veh)		
		Demand	Served	% Served		Average	Std. Dev.	LOS
NB	Left Turn	60	59	97.7%	0.2	65.4	11.8	E
	Through	310	307	98.9%	0.2	23.3	1.1	C
	Right Turn	140	145	103.4%	0.4	19.3	2.0	B
	Subtotal	510	510	100.0%	0.0	27.1	2.0	C
SB	Left Turn	120	120	99.6%	0.0	93.3	23.8	F
	Through	210	207	98.4%	0.2	18.8	1.8	B
	Right Turn	60	64	106.0%	0.5	14.1	2.3	B
	Subtotal	390	390	99.9%	0.0	41.1	8.5	D
EB	Left Turn	50	48	96.2%	0.3	56.0	7.7	E
	Through	480	476	99.2%	0.2	22.1	1.2	C
	Right Turn	30	32	106.0%	0.3	19.3	3.2	B
	Subtotal	560	556	99.3%	0.2	24.9	1.5	C
WB	Left Turn	110	112	101.5%	0.2	104.8	19.2	F
	Through	420	429	102.1%	0.4	20.6	2.3	C
	Right Turn	120	120	99.8%	0.0	18.7	2.2	B
	Subtotal	650	660	101.6%	0.4	34.5	3.8	C
Total		2110	2116	100.3%	0.1	31.4	2.0	C

Intersection Pennsylvania Street/22nd Street

Unsignalized

Direction	Movement	Volume (veh/hr)			GEH	Total Delay (sec/veh)		
		Demand	Served	% Served		Average	Std. Dev.	LOS
NB	Left Turn	50	47	94.0%	0.4	8.0	0.7	A
	Through	190	184	97.1%	0.4	8.9	0.6	A
	Right Turn	50	51	101.8%	0.1	6.9	1.3	A
	Subtotal	290	282	97.3%	0.5	8.4	0.6	A
SB	Left Turn	30	29	98.0%	0.1	6.6	0.8	A
	Through	110	109	98.9%	0.1	7.5	0.5	A
	Right Turn	10	12	120.0%	0.6	5.5	1.1	A
	Subtotal	150	150	100.1%	0.0	7.2	0.5	A
EB	Left Turn	10	11	105.0%	0.2	5.4	0.8	A
	Through	50	51	101.6%	0.1	6.8	0.7	A
	Right Turn	70	72	103.4%	0.3	4.9	0.3	A
	Subtotal	130	134	102.8%	0.3	5.7	0.4	A
WB	Left Turn	100	101	100.9%	0.1	6.1	0.4	A
	Through	30	32	107.7%	0.4	6.3	0.7	A
	Right Turn	20	20	98.5%	0.1	4.8	1.0	A
	Subtotal	150	153	101.9%	0.2	6.0	0.4	A
Total		720	719	99.9%	0.0	7.1	0.4	A

Intersection Indiana Street/22nd Street

Unsignalized

Direction	Movement	Volume (veh/hr)			GEH	Total Delay (sec/veh)		
		Demand	Served	% Served		Average	Std. Dev.	LOS
NB	Left Turn	30	34	112.3%	0.7	6.4	0.6	A
	Through	70	66	93.6%	0.5	6.8	0.3	A
	Right Turn	60	61	101.8%	0.1	4.7	0.6	A
	Subtotal	160	160	100.2%	0.0	5.9	0.3	A
SB	Left Turn	10	10	100.0%	0.0	5.1	0.7	A
	Through	20	18	89.5%	0.5	6.5	0.6	A
	Right Turn	40	40	101.0%	0.1	4.1	0.4	A
	Subtotal	70	68	97.6%	0.2	4.9	0.3	A
EB	Left Turn	10	11	109.0%	0.3	5.2	0.7	A
	Through	70	69	99.0%	0.1	5.7	0.4	A
	Right Turn	10	10	101.0%	0.0	3.3	0.5	A
	Subtotal	90	90	100.3%	0.0	5.4	0.3	A
WB	Left Turn	10	10	97.0%	0.1	5.8	1.6	A
	Through	150	152	101.4%	0.2	6.2	0.3	A
	Right Turn	10	10	97.0%	0.1	4.3	0.8	A
	Subtotal	170	172	100.9%	0.1	6.0	0.3	A
Total		490	490	100.1%	0.0	5.7	0.2	A

SimTraffic Post-Processor
Average Results from 20 Runs
Volume and Delay by Movement

Caltrain Electrification
2020 Plus Project Conditions
PM Peak Hour

Intersection

Tunnel Avenue/Blanken Avenue

Unsignalized

Direction	Movement	Volume (veh/hr)			GEH	Total Delay (sec/veh)		
		Demand	Served	% Served		Average	Std. Dev.	LOS
NB	Left Turn	30	31	104.3%	0.2	24.7	6.5	C
	Through	240	235	97.9%	0.3	26.3	3.7	D
	Right Turn	10	9	89.0%	0.4	24.7	9.9	C
	Subtotal	280	275	98.3%	0.3	26.1	4.0	D
SB	Left Turn	100	100	99.9%	0.0	13.6	1.6	B
	Through	90	90	100.4%	0.0	15.3	1.6	C
	Right Turn	10	9	89.0%	0.4	12.1	5.2	B
	Subtotal	200	199	99.6%	0.1	14.3	1.3	B
EB	Left Turn	10	9	89.0%	0.4	11.5	2.8	B
	Through	60	58	97.2%	0.2	12.5	1.7	B
	Right Turn	130	128	98.4%	0.2	9.7	0.9	A
	Subtotal	200	195	97.6%	0.3	10.6	1.0	B
WB	Left Turn	10	11	105.0%	0.2	35.0	6.7	D
	Through	240	242	100.7%	0.1	39.0	7.2	E
	Right Turn	120	119	99.3%	0.1	35.5	8.7	E
	Subtotal	370	371	100.4%	0.1	37.8	7.5	E
Total		1050	1041	99.1%	0.3	25.1	2.9	D

Intersection

Dubuque Way/Grand Avenue

Signalized

Direction	Movement	Volume (veh/hr)			GEH	Total Delay (sec/veh)		
		Demand	Served	% Served		Average	Std. Dev.	LOS
NB	Left Turn							
	Through							
	Right Turn							
	Subtotal							
SB	Left Turn	30	29	98.0%	0.1	37.0	3.0	D
	Through							
	Right Turn	70	67	95.3%	0.4	14.5	1.3	B
	Subtotal	100	96	96.1%	0.4	21.4	1.6	C
EB	Left Turn	40	35	86.5%	0.9	43.1	3.8	D
	Through	240	245	102.3%	0.3	5.3	1.1	A
	Right Turn							
	Subtotal	280	280	100.0%	0.0	10.0	1.1	A
WB	Left Turn							
	Through	1610	1575	97.8%	0.9	12.2	0.9	B
	Right Turn	80	78	96.9%	0.3	13.0	2.3	B
	Subtotal	1690	1653	97.8%	0.9	12.2	0.9	B
Total		2070	2029	98.0%	0.9	12.3	0.9	B

Intersection **Linden Avenue-San Mateo Avenue/San Mateo Avenue** Signalized

Direction	Movement	Volume (veh/hr)			GEH	Total Delay (sec/veh)		
		Demand	Served	% Served		Average	Std. Dev.	LOS
NB	Left Turn							
	Through	130	140	107.5%	0.8	34.3	19.9	C
	Right Turn	260	271	104.3%	0.7	1.5	0.1	A
	Subtotal	390	411	105.4%	1.0	12.6	6.7	B
SB	Left Turn	130	126	96.6%	0.4	40.5	22.1	D
	Through	130	134	103.2%	0.4	4.4	1.3	A
	Right Turn							
	Subtotal	260	260	99.9%	0.0	22.1	11.7	C
EB	Left Turn							
	Through							
	Right Turn							
	Subtotal							
WB	Left Turn	220	218	98.9%	0.2	25.7	11.7	C
	Through							
	Right Turn	160	155	97.1%	0.4	23.7	17.4	C
	Subtotal	380	373	98.1%	0.4	24.9	13.5	C
Total		1030	1043	101.3%	0.4	19.4	8.5	B

Intersection **Herman Street/Scott Street** Unsignalized

Direction	Movement	Volume (veh/hr)			GEH	Total Delay (sec/veh)		
		Demand	Served	% Served		Average	Std. Dev.	LOS
NB	Left Turn	10	10	100.0%	0.0	11.1	3.7	B
	Through	110	109	99.1%	0.1	12.6	2.1	B
	Right Turn	120	120	99.9%	0.0	8.3	1.7	A
	Subtotal	240	239	99.5%	0.1	10.4	1.9	B
SB	Left Turn	50	51	101.0%	0.1	14.6	1.3	B
	Through	160	154	96.5%	0.4	15.0	1.6	B
	Right Turn	10	12	119.0%	0.6	9.3	1.4	A
	Subtotal	220	217	98.5%	0.2	14.6	1.4	B
EB	Left Turn	10	10	99.0%	0.0	6.3	0.9	A
	Through	20	19	92.5%	0.3	11.7	2.7	B
	Right Turn	10	10	103.0%	0.1	5.4	0.6	A
	Subtotal	40	39	96.8%	0.2	8.6	1.6	A
WB	Left Turn	170	172	101.1%	0.1	0.2	0.1	A
	Through	20	22	108.0%	0.4	0.3	0.1	A
	Right Turn	30	29	95.7%	0.2	0.1	0.1	A
	Subtotal	220	222	101.0%	0.1	0.2	0.1	A
Total		720	717	99.5%	0.1	8.4	1.0	A

SimTraffic Post-Processor
Average Results from 20 Runs
Volume and Delay by Movement

Caltrain Electrification
2020 Plus Project Conditions
PM Peak Hour

Intersection **Montgomery Avenue/Scott Street**

Unsignalized

Direction	Movement	Volume (veh/hr)			GEH	Total Delay (sec/veh)		
		Demand	Served	% Served		Average	Std. Dev.	LOS
NB	Left Turn	30	28	94.0%	0.3	8.5	3.0	A
	Through	10	10	98.0%	0.1	8.4	1.7	A
	Right Turn	20	19	94.5%	0.2	4.0	1.2	A
	Subtotal	60	57	94.8%	0.4	6.9	1.8	A
SB	Left Turn	10	11	107.0%	0.2	6.4	1.1	A
	Through	10	10	99.0%	0.0	8.5	1.5	A
	Right Turn	20	20	98.0%	0.1	3.9	0.6	A
	Subtotal	40	40	100.5%	0.0	5.8	0.9	A
EB	Left Turn	20	20	97.5%	0.1	2.3	0.3	A
	Through	140	138	98.6%	0.2	0.6	0.1	A
	Right Turn	30	31	102.7%	0.1	0.4	0.1	A
	Subtotal	190	188	99.2%	0.1	0.7	0.1	A
WB	Left Turn	20	20	98.5%	0.1	2.0	0.5	A
	Through	170	173	101.8%	0.2	0.5	0.1	A
	Right Turn	10	10	102.0%	0.1	0.2	0.1	A
	Subtotal	200	203	101.5%	0.2	0.6	0.1	A
Total		490	489	99.7%	0.1	1.8	0.3	A

Intersection **Driveway-Dollar Avenue/Linden Avenue**

Signalized

Direction	Movement	Volume (veh/hr)			GEH	Total Delay (sec/veh)		
		Demand	Served	% Served		Average	Std. Dev.	LOS
NB	Left Turn	90	89	99.0%	0.1	72.5	31.2	E
	Through							
	Right Turn	50	47	94.4%	0.4	76.8	39.4	E
	Subtotal	140	136	97.4%	0.3	73.8	33.7	E
SB	Left Turn	10	9	93.0%	0.2	112.1	25.5	F
	Through							
	Right Turn							
	Subtotal	10	9	93.0%	0.2	112.1	25.5	F
EB	Left Turn							
	Through	230	227	98.6%	0.2	86.2	10.6	F
	Right Turn	120	122	101.7%	0.2	76.3	12.4	E
	Subtotal	350	349	99.7%	0.1	82.8	11.1	F
WB	Left Turn	50	52	104.6%	0.3	11.9	7.6	B
	Through	230	243	105.8%	0.9	10.4	2.5	B
	Right Turn	10	9	91.0%	0.3	6.6	7.0	A
	Subtotal	290	305	105.1%	0.9	10.5	3.1	B
Total		790	799	101.2%	0.3	54.1	8.6	D

SimTraffic Post-Processor
Average Results from 20 Runs
Volume and Delay by Movement

Caltrain Electrification
2020 Plus Project Conditions
PM Peak Hour

Intersection

San Mateo Avenue/San Bruno Avenue

Signalized

Direction	Movement	Volume (veh/hr)			GEH	Total Delay (sec/veh)		
		Demand	Served	% Served		Average	Std. Dev.	LOS
NB	Left Turn	30	25	82.7%	1.0	32.9	6.2	C
	Through	110	115	104.1%	0.4	27.9	2.9	C
	Right Turn	200	203	101.3%	0.2	8.7	1.2	A
	Subtotal	340	342	100.6%	0.1	16.9	2.3	B
SB	Left Turn	120	119	98.8%	0.1	37.8	4.2	D
	Through	100	103	103.0%	0.3	32.6	5.4	C
	Right Turn	120	121	100.9%	0.1	19.9	4.7	B
	Subtotal	340	343	100.8%	0.1	30.0	4.3	C
EB	Left Turn	20	22	110.0%	0.4	17.6	3.3	B
	Through	490	505	103.1%	0.7	7.0	0.6	A
	Right Turn	10	10	104.0%	0.1	2.5	2.4	A
	Subtotal	520	538	103.4%	0.8	7.3	0.6	A
WB	Left Turn	190	184	97.0%	0.4	43.2	2.0	D
	Through	600	602	100.4%	0.1	17.8	1.2	B
	Right Turn	70	73	104.9%	0.4	13.4	1.8	B
	Subtotal	860	860	100.0%	0.0	22.9	1.1	C
Total		2060	2082	101.1%	0.5	19.1	1.2	B

SimTraffic Post-Processor
Average Results from 20 Runs
Volume and Delay by Movement

Caltrain Electrification
2020 Plus Project Conditions
PM Peak Hour

Intersection **El Camino Real/Millbrae Avenue**

Signalized

Direction	Movement	Volume (veh/hr)			GEH	Total Delay (sec/veh)		
		Demand	Served	% Served		Average	Std. Dev.	LOS
NB	Left Turn	40	42	104.0%	0.3	74.7	5.5	E
	Through	870	878	100.9%	0.3	46.0	4.9	D
	Right Turn	420	426	101.3%	0.3	4.0	0.6	A
	Subtotal	1330	1345	101.1%	0.4	33.6	3.6	C
SB	Left Turn	690	577	83.6%	4.5	488.9	74.0	F
	Through	1090	941	86.3%	4.7	302.4	85.8	F
	Right Turn	70	58	82.1%	1.6	323.7	111.6	F
	Subtotal	1850	1576	85.2%	6.6	371.1	83.1	F
EB	Left Turn	140	139	98.9%	0.1	208.5	114.5	F
	Through	430	419	97.3%	0.6	64.3	23.9	E
	Right Turn	60	64	107.0%	0.5	52.3	15.0	D
	Subtotal	630	621	98.6%	0.3	95.6	44.0	F
WB	Left Turn	610	602	98.7%	0.3	74.3	6.5	E
	Through	790	776	98.2%	0.5	47.8	1.6	D
	Right Turn	750	735	97.9%	0.6	17.6	1.4	B
	Subtotal	2150	2113	98.3%	0.8	44.9	1.7	D
Total		5960	5654	94.9%	4.0	138.5	23.3	F

Intersection **Rollins Road/Millbrae Avenue**

Signalized

Direction	Movement	Volume (veh/hr)			GEH	Total Delay (sec/veh)		
		Demand	Served	% Served		Average	Std. Dev.	LOS
NB	Left Turn	360	366	101.5%	0.3	49.7	3.3	D
	Through	90	90	99.8%	0.0	46.5	4.0	D
	Right Turn	450	442	98.2%	0.4	28.0	2.0	C
	Subtotal	900	897	99.7%	0.1	38.7	1.9	D
SB	Left Turn	390	385	98.7%	0.3	34.5	1.4	C
	Through	120	128	106.3%	0.7	33.8	3.0	C
	Right Turn	250	255	102.0%	0.3	22.5	3.1	C
	Subtotal	760	767	101.0%	0.3	30.4	1.4	C
EB	Left Turn	200	162	80.8%	2.9	335.8	146.6	F
	Through	1120	1025	91.5%	2.9	42.0	3.7	D
	Right Turn	220	206	93.8%	0.9	17.8	1.2	B
	Subtotal	1540	1393	90.4%	3.8	72.7	19.8	E
WB	Left Turn	360	349	96.9%	0.6	141.0	50.4	F
	Through	1540	1485	96.4%	1.4	154.8	57.3	F
	Right Turn	240	246	102.5%	0.4	62.4	44.1	E
	Subtotal	2140	2079	97.2%	1.3	141.5	54.4	F
Total		5340	5137	96.2%	2.8	88.2	23.6	F

Intersection

California Drive/Oak Grove

Signalized

Direction	Movement	Volume (veh/hr)			GEH	Total Delay (sec/veh)		
		Demand	Served	% Served		Average	Std. Dev.	LOS
NB	Left Turn	50	49	97.0%	0.2	57.4	5.8	E
	Through	580	591	101.8%	0.4	24.7	2.1	C
	Right Turn	250	237	94.9%	0.8	9.0	1.6	A
	Subtotal	880	876	99.6%	0.1	22.2	1.6	C
SB	Left Turn	60	60	100.5%	0.0	105.9	49.7	F
	Through	710	729	102.7%	0.7	27.4	2.4	C
	Right Turn	70	72	102.6%	0.2	12.0	1.2	B
	Subtotal	840	861	102.5%	0.7	31.6	5.1	C
EB	Left Turn	30	30	101.0%	0.1	51.0	9.5	D
	Through	250	250	99.9%	0.0	56.0	10.5	E
	Right Turn	40	41	103.3%	0.2	46.0	12.1	D
	Subtotal	320	321	100.4%	0.1	54.2	10.3	D
WB	Left Turn	200	144	72.1%	4.3	25.3	2.1	C
	Through	180	120	66.7%	4.9	25.0	2.8	C
	Right Turn	140	93	66.1%	4.4	14.7	1.3	B
	Subtotal	520	357	68.6%	7.8	22.4	1.2	C
Total		2560	2416	94.4%	2.9	29.9	2.9	C

Intersection

Carolan Ave/Oak Grove

Unsignalized

Direction	Movement	Volume (veh/hr)			GEH	Total Delay (sec/veh)		
		Demand	Served	% Served		Average	Std. Dev.	LOS
NB	Left Turn	70	57	81.3%	1.6	326.9	74.5	F
	Through	80	73	91.8%	0.8	297.1	83.6	F
	Right Turn	70	64	91.7%	0.7	297.1	78.4	F
	Subtotal	220	195	88.4%	1.8	305.3	77.9	F
SB	Left Turn	30	20	67.7%	1.9	221.8	18.2	F
	Through	170	108	63.3%	5.3	217.3	7.8	F
	Right Turn	260	160	61.5%	6.9	471.7	24.0	F
	Subtotal	460	288	62.5%	8.9	358.8	14.9	F
EB	Left Turn	400	387	96.8%	0.6	0.5	0.1	A
	Through	90	100	111.3%	1.0	1.0	0.1	A
	Right Turn	70	71	100.9%	0.1	0.2	0.1	A
	Subtotal	560	558	99.7%	0.1	0.5	0.1	A
WB	Left Turn	50	32	63.8%	2.8	469.3	37.5	F
	Through	190	125	65.7%	5.2	492.0	40.9	F
	Right Turn	30	22	71.7%	1.7	471.7	52.8	F
	Subtotal	270	178	66.0%	6.1	485.5	40.7	F
Total		1510	1219	80.7%	7.9	203.8	9.8	F

Intersection

California Dr/North Lane

Unsignalized

Direction	Movement	Volume (veh/hr)			GEH	Total Delay (sec/veh)		
		Demand	Served	% Served		Average	Std. Dev.	LOS
NB	Left Turn							
	Through	680	681	100.2%	0.0	1.1	0.2	A
	Right Turn	60	62	103.2%	0.2	2.5	0.4	A
	Subtotal	740	743	100.4%	0.1	1.2	0.1	A
SB	Left Turn	140	133	95.0%	0.6	15.6	3.1	C
	Through	800	778	97.2%	0.8	5.5	0.7	A
	Right Turn							
	Subtotal	940	911	96.9%	1.0	7.0	0.9	A
EB	Left Turn							
	Through							
	Right Turn							
	Subtotal							
WB	Left Turn	50	46	92.0%	0.6	30.5	4.6	D
	Through							
	Right Turn	130	111	85.5%	1.7	5.6	0.4	A
	Subtotal	180	157	87.3%	1.8	12.9	1.6	B
Total		1860	1811	97.3%	1.2	5.1	0.5	A

Intersection

Carolan Ave/North Lane

Unsignalized

Direction	Movement	Volume (veh/hr)			GEH	Total Delay (sec/veh)		
		Demand	Served	% Served		Average	Std. Dev.	LOS
NB	Left Turn	100	95	95.3%	0.5	23.9	7.6	C
	Through	130	128	98.1%	0.2	9.7	1.2	A
	Right Turn	10	10	99.0%	0.0	6.2	1.9	A
	Subtotal	240	233	97.0%	0.5	15.4	3.7	C
SB	Left Turn	10	6	56.0%	1.6	13.5	11.0	B
	Through	180	141	78.3%	3.1	12.9	1.5	B
	Right Turn	80	62	77.6%	2.1	15.0	5.4	B
	Subtotal	270	209	77.3%	4.0	13.6	2.6	B
EB	Left Turn	70	68	96.6%	0.3	0.7	0.2	A
	Through	10	14	137.0%	1.1	0.7	0.4	A
	Right Turn	120	120	100.3%	0.0	0.5	0.2	A
	Subtotal	200	202	100.8%	0.1	0.6	0.1	A
WB	Left Turn							
	Through							
	Right Turn							
	Subtotal							
Total		710	643	90.5%	2.6	10.2	2.2	B

Intersection Anita Road/Peninsula Avenue

Unsignalized

Direction	Movement	Volume (veh/hr)			GEH	Total Delay (sec/veh)		
		Demand	Served	% Served		Average	Std. Dev.	LOS
NB	Left Turn							
	Through							
	Right Turn							
	Subtotal							
SB	Left Turn	20	21	104.5%	0.2	26.6	13.9	D
	Through							
	Right Turn	20	20	98.5%	0.1	40.1	18.2	E
	Subtotal	40	41	101.5%	0.1	33.4	14.5	D
EB	Left Turn	20	21	104.5%	0.2	9.8	2.7	A
	Through	640	633	98.9%	0.3	0.7	0.2	A
	Right Turn							
	Subtotal	660	654	99.1%	0.2	1.0	0.3	A
WB	Left Turn							
	Through	640	627	97.9%	0.5	11.3	3.1	B
	Right Turn	40	37	91.3%	0.6	10.5	4.1	B
	Subtotal	680	663	97.5%	0.6	11.2	3.1	B
Total		1380	1358	98.4%	0.6	7.0	2.1	A

Intersection Woodside Way/Villa Terrace

Unsignalized

Direction	Movement	Volume (veh/hr)			GEH	Total Delay (sec/veh)		
		Demand	Served	% Served		Average	Std. Dev.	LOS
NB	Left Turn	10	11	109.0%	0.3	4.6	0.5	A
	Through	20	19	93.5%	0.3	5.9	0.4	A
	Right Turn	10	10	97.0%	0.1	2.7	0.4	A
	Subtotal	40	39	98.3%	0.1	4.7	0.3	A
SB	Left Turn	20	20	102.0%	0.1	5.6	0.4	A
	Through	50	51	101.0%	0.1	7.1	0.3	A
	Right Turn	60	61	101.5%	0.1	3.7	0.4	A
	Subtotal	130	132	101.4%	0.2	5.3	0.2	A
EB	Left Turn	30	27	88.7%	0.6	2.8	0.3	A
	Through	30	30	101.3%	0.1	2.4	0.5	A
	Right Turn	20	21	105.5%	0.2	1.3	0.2	A
	Subtotal	80	78	97.6%	0.2	2.2	0.3	A
WB	Left Turn	10	11	107.0%	0.2	2.1	0.5	A
	Through	30	29	97.3%	0.1	0.6	0.1	A
	Right Turn	20	19	95.0%	0.2	0.2	0.1	A
	Subtotal	60	59	98.2%	0.1	0.8	0.1	A
Total		310	308	99.4%	0.1	3.6	0.2	A

Intersection N. San Mateo Drive/Villa Terrace

Unsignalized

Direction	Movement	Volume (veh/hr)			GEH	Total Delay (sec/veh)		
		Demand	Served	% Served		Average	Std. Dev.	LOS
NB	Left Turn	10	10	103.0%	0.1	5.5	3.2	A
	Through	580	584	100.7%	0.2	0.6	0.1	A
	Right Turn	50	50	99.6%	0.0	0.7	0.2	A
	Subtotal	640	644	100.7%	0.2	0.7	0.1	A
SB	Left Turn	20	19	97.0%	0.1	6.5	0.9	A
	Through	510	508	99.5%	0.1	2.9	0.3	A
	Right Turn	20	21	103.5%	0.2	3.1	0.7	A
	Subtotal	550	548	99.6%	0.1	3.0	0.3	A
EB	Left Turn	10	8	80.0%	0.7	8.7	2.2	A
	Through	10	10	103.0%	0.1	16.2	3.9	C
	Right Turn	20	21	106.5%	0.3	6.0	1.1	A
	Subtotal	40	40	99.0%	0.1	9.1	1.3	A
WB	Left Turn	40	43	108.0%	0.5	17.5	1.9	C
	Through	20	19	94.0%	0.3	20.6	3.3	C
	Right Turn	40	39	97.3%	0.2	12.0	2.2	B
	Subtotal	100	101	100.9%	0.1	16.0	2.1	C
Total		1330	1333	100.2%	0.1	3.1	0.3	A

Intersection Arundel Road/Peninsula Avenue

Unsignalized

Direction	Movement	Volume (veh/hr)			GEH	Total Delay (sec/veh)		
		Demand	Served	% Served		Average	Std. Dev.	LOS
NB	Left Turn	20	18	91.5%	0.4	37.3	6.3	E
	Through	10	10	95.0%	0.2	35.4	12.9	E
	Right Turn	40	37	92.0%	0.5	15.4	8.9	C
	Subtotal	70	65	92.3%	0.7	24.5	7.5	C
SB	Left Turn	20	17	83.5%	0.8	33.7	10.6	D
	Through	10	10	102.0%	0.1	41.3	15.9	E
	Right Turn	20	20	99.5%	0.0	23.6	13.3	C
	Subtotal	50	47	93.6%	0.5	31.2	12.3	D
EB	Left Turn	10	9	88.0%	0.4	5.0	2.4	A
	Through	590	581	98.5%	0.4	1.1	0.1	A
	Right Turn	60	62	103.5%	0.3	0.9	0.1	A
	Subtotal	660	652	98.8%	0.3	1.1	0.1	A
WB	Left Turn	60	59	98.5%	0.1	13.3	3.7	B
	Through	640	625	97.7%	0.6	8.8	2.9	A
	Right Turn	30	32	105.0%	0.3	6.6	1.7	A
	Subtotal	730	716	98.0%	0.5	9.1	2.8	A
Total		1510	1479	98.0%	0.8	6.9	1.7	A

Intersection **Railroad Ave/1st Ave**

Unsignalized

Direction	Movement	Volume (veh/hr)			GEH	Total Delay (sec/veh)		
		Demand	Served	% Served		Average	Std. Dev.	LOS
NB	Left Turn	20	22	108.5%	0.4	19.6	7.3	C
	Through	20	23	116.0%	0.7	11.9	2.5	B
	Right Turn	10	10	103.0%	0.1	8.7	6.1	A
	Subtotal	50	55	110.4%	0.7	14.3	3.7	B
SB	Left Turn							
	Through							
	Right Turn							
	Subtotal							
EB	Left Turn	10	9	93.0%	0.2	2.5	1.3	A
	Through	280	264	94.2%	1.0	0.4	0.1	A
	Right Turn							
	Subtotal	290	273	94.1%	1.0	0.5	0.1	A
WB	Left Turn							
	Through	230	231	100.5%	0.1	7.2	2.6	A
	Right Turn	10	12	115.0%	0.5	6.3	5.5	A
	Subtotal	240	243	101.1%	0.2	7.2	2.6	A
Total		580	571	98.4%	0.4	4.7	1.3	A

Intersection **S. B. St/1st Ave**

Signalized

Direction	Movement	Volume (veh/hr)			GEH	Total Delay (sec/veh)		
		Demand	Served	% Served		Average	Std. Dev.	LOS
NB	Left Turn	60	51	85.5%	1.2	80.6	9.0	F
	Through	390	362	92.8%	1.4	73.1	3.9	E
	Right Turn	80	71	88.8%	1.0	73.4	14.3	E
	Subtotal	530	484	91.4%	2.0	73.9	4.4	E
SB	Left Turn	80	73	91.0%	0.8	73.1	8.5	E
	Through	210	194	92.5%	1.1	58.9	6.0	E
	Right Turn	40	37	91.8%	0.5	57.4	10.2	E
	Subtotal	330	304	92.0%	1.5	62.2	6.4	E
EB	Left Turn	20	18	91.0%	0.4	22.5	10.7	C
	Through	140	131	93.9%	0.7	21.4	5.9	C
	Right Turn	50	54	107.2%	0.5	13.6	5.1	B
	Subtotal	210	203	96.8%	0.5	19.4	5.5	B
WB	Left Turn	40	40	99.8%	0.0	17.9	2.5	B
	Through	90	91	101.3%	0.1	12.3	2.3	B
	Right Turn	80	81	101.6%	0.1	9.9	2.0	A
	Subtotal	210	212	101.1%	0.2	12.4	2.0	B
Total		1280	1204	94.0%	2.2	50.8	1.5	D

Intersection

Transit Center Way/1st St

Unsignalized

Direction	Movement	Volume (veh/hr)			GEH	Total Delay (sec/veh)		
		Demand	Served	% Served		Average	Std. Dev.	LOS
NB	Left Turn	50	46	92.2%	0.6	13.2	4.8	B
	Through	10	9	89.0%	0.4	13.1	6.8	B
	Right Turn	50	53	105.4%	0.4	9.7	7.4	A
	Subtotal	110	108	97.9%	0.2	11.4	5.7	B
SB	Left Turn							
	Through							
	Right Turn							
	Subtotal							
EB	Left Turn	50	48	95.6%	0.3	5.4	1.4	A
	Through	240	231	96.3%	0.6	2.9	0.7	A
	Right Turn	10	7	74.0%	0.9	1.2	0.5	A
	Subtotal	300	286	95.4%	0.8	3.3	0.7	A
WB	Left Turn							
	Through	160	170	105.9%	0.7	2.1	0.6	A
	Right Turn	90	90	100.1%	0.0	0.9	0.3	A
	Subtotal	250	260	103.8%	0.6	1.7	0.4	A
Total		660	654	99.0%	0.2	4.0	1.2	A

Intersection **Railroad Avenue/9th Avenue**

Unsignalized

Direction	Movement	Volume (veh/hr)			GEH	Total Delay (sec/veh)		
		Demand	Served	% Served		Average	Std. Dev.	LOS
NB	Left Turn	40	39	96.8%	0.2	49.2	23.3	E
	Through							
	Right Turn	50	53	105.8%	0.4	26.4	11.8	D
	Subtotal	90	92	101.8%	0.2	35.7	14.9	E
SB	Left Turn							
	Through							
	Right Turn							
	Subtotal							
EB	Left Turn							
	Through	440	426	96.9%	0.7	0.7	0.1	A
	Right Turn	30	29	97.7%	0.1	0.3	0.4	A
	Subtotal	470	456	96.9%	0.7	0.7	0.1	A
WB	Left Turn	10	9	90.0%	0.3	8.9	3.7	A
	Through	480	485	101.1%	0.2	5.0	0.9	A
	Right Turn							
	Subtotal	490	494	100.9%	0.2	5.1	0.9	A
Total		1050	1042	99.2%	0.3	5.9	1.5	A

Intersection **S B Street/9th Avenue**

Signalized

Direction	Movement	Volume (veh/hr)			GEH	Total Delay (sec/veh)		
		Demand	Served	% Served		Average	Std. Dev.	LOS
NB	Left Turn	10	10	104.0%	0.1	22.6	3.8	C
	Through	130	125	96.3%	0.4	14.3	1.0	B
	Right Turn	140	134	95.5%	0.5	8.4	1.1	A
	Subtotal	280	269	96.2%	0.6	11.7	0.9	B
SB	Left Turn	90	87	96.3%	0.4	25.1	3.8	C
	Through	180	182	100.8%	0.1	13.5	1.2	B
	Right Turn	70	70	99.9%	0.0	8.6	1.1	A
	Subtotal	340	338	99.4%	0.1	15.4	1.4	B
EB	Left Turn	70	68	97.0%	0.3	45.6	8.7	D
	Through	240	236	98.4%	0.3	38.5	5.3	D
	Right Turn	20	20	101.5%	0.1	33.5	8.8	C
	Subtotal	330	324	98.3%	0.3	39.7	5.8	D
WB	Left Turn	90	91	101.2%	0.1	15.4	1.9	B
	Through	300	300	99.8%	0.0	11.0	0.9	B
	Right Turn	130	127	97.5%	0.3	7.3	0.4	A
	Subtotal	520	517	99.5%	0.1	10.9	0.7	B
Total		1470	1449	98.6%	0.5	18.5	1.1	B

SimTraffic Post-Processor
Average Results from 20 Runs
Volume and Delay by Movement

Caltrain Electrification
2020 Plus Project Conditions
PM Peak Hour

Intersection

Concar Drive/SR 92 WB Ramps

Signalized

Direction	Movement	Volume (veh/hr)			GEH	Total Delay (sec/veh)		
		Demand	Served	% Served		Average	Std. Dev.	LOS
NB	Left Turn	110	109	99.5%	0.1	19.7	1.4	B
	Through	50	53	106.2%	0.4	16.2	1.8	B
	Right Turn							
	Subtotal	160	163	101.6%	0.2	18.5	1.1	B
SB	Left Turn	30	28	94.7%	0.3	26.4	3.9	C
	Through	50	54	108.4%	0.6	17.5	2.4	B
	Right Turn	10	10	102.0%	0.1	7.3	4.7	A
	Subtotal	90	93	103.1%	0.3	19.2	2.5	B
EB	Left Turn	10	10	95.0%	0.2	73.5	30.0	E
	Through	70	72	102.6%	0.2	95.1	37.7	F
	Right Turn	80	81	101.5%	0.1	70.2	34.4	E
	Subtotal	160	163	101.6%	0.2	81.6	35.4	F
WB	Left Turn	690	692	100.3%	0.1	5.6	0.7	A
	Through	110	113	102.5%	0.3	7.1	0.9	A
	Right Turn	50	53	106.2%	0.4	1.7	0.4	A
	Subtotal	850	858	101.0%	0.3	5.6	0.6	A
Total		1260	1276	101.3%	0.4	18.0	5.0	B

Intersection

Delaware Ave/25th Ave

Signalized

Direction	Movement	Volume (veh/hr)			GEH	Total Delay (sec/veh)		
		Demand	Served	% Served		Average	Std. Dev.	LOS
NB	Left Turn	60	42	69.3%	2.6	386.7	257.8	F
	Through	10	11	110.0%	0.3	17.8	5.4	B
	Right Turn							
	Subtotal	70	53	75.1%	2.2	299.8	190.7	F
SB	Left Turn							
	Through	10	9	94.0%	0.2	16.0	5.4	B
	Right Turn	680	663	97.4%	0.7	59.5	27.8	E
	Subtotal	690	672	97.4%	0.7	58.8	27.4	E
EB	Left Turn	610	597	97.8%	0.5	8.2	0.6	A
	Through							
	Right Turn	50	49	98.4%	0.1	3.3	0.5	A
	Subtotal	660	646	97.8%	0.6	7.8	0.5	A
WB	Left Turn							
	Through							
	Right Turn							
	Subtotal							
Total		1420	1370	96.5%	1.3	43.2	17.6	D

Intersection

El Camino Real/25th Ave

Signalized

Direction	Movement	Volume (veh/hr)			GEH	Total Delay (sec/veh)		
		Demand	Served	% Served		Average	Std. Dev.	LOS
NB	Left Turn	110	114	103.2%	0.3	84.0	12.5	F
	Through	1740	1724	99.1%	0.4	68.2	12.4	E
	Right Turn	320	319	99.8%	0.0	81.1	15.1	F
	Subtotal	2170	2157	99.4%	0.3	70.9	12.7	E
SB	Left Turn	200	192	95.8%	0.6	216.1	62.6	F
	Through	1290	1291	100.1%	0.0	35.4	1.8	D
	Right Turn	120	121	100.9%	0.1	39.4	3.6	D
	Subtotal	1610	1604	99.6%	0.2	57.4	9.0	E
EB	Left Turn	220	199	90.5%	1.4	248.1	66.6	F
	Through	140	132	94.0%	0.7	289.4	64.3	F
	Right Turn	80	77	96.1%	0.3	208.6	68.7	F
	Subtotal	440	408	92.6%	1.6	254.1	66.5	F
WB	Left Turn	500	461	92.1%	1.8	76.3	4.5	E
	Through	190	180	94.7%	0.7	85.9	3.7	F
	Right Turn	120	112	93.7%	0.7	47.7	6.6	D
	Subtotal	810	753	93.0%	2.0	74.3	4.2	E
Total		5030	4921	97.8%	1.5	82.2	4.0	F

Intersection El Camino Real/31st Street

Signalized

Direction	Movement	Volume (veh/hr)			GEH	Total Delay (sec/veh)		
		Demand	Served	% Served		Average	Std. Dev.	LOS
NB	Left Turn	160	164	102.6%	0.3	62.1	9.8	E
	Through	1760	1726	98.1%	0.8	33.3	2.6	C
	Right Turn	20	19	95.0%	0.2	2.2	0.4	A
	Subtotal	1940	1909	98.4%	0.7	35.4	2.5	D
SB	Left Turn	280	278	99.1%	0.1	89.2	34.4	F
	Through	1720	1700	98.8%	0.5	44.4	7.8	D
	Right Turn	70	70	100.0%	0.0	26.2	4.0	C
	Subtotal	2070	2048	98.9%	0.5	50.1	10.2	D
EB	Left Turn	260	264	101.6%	0.3	85.5	34.6	F
	Through	30	31	103.7%	0.2	99.8	33.7	F
	Right Turn	170	164	96.6%	0.4	7.3	1.0	A
	Subtotal	460	460	99.9%	0.0	58.9	23.4	E
WB	Left Turn	90	86	95.4%	0.4	28.6	2.3	C
	Through	30	26	86.3%	0.8	28.5	3.8	C
	Right Turn	20	22	111.5%	0.5	13.7	2.5	B
	Subtotal	140	134	95.8%	0.5	26.2	1.4	C
Total		4610	4550	98.7%	0.9	44.2	5.0	D

Intersection El Camino Real/Hillsdale Blvd

Signalized

Direction	Movement	Volume (veh/hr)			GEH	Total Delay (sec/veh)		
		Demand	Served	% Served		Average	Std. Dev.	LOS
NB	Left Turn							
	Through							
	Right Turn							
	Subtotal							
SB	Left Turn	570	551	96.7%	0.8	45.2	4.4	D
	Through							
	Right Turn	170	171	100.8%	0.1	13.3	1.6	B
	Subtotal	740	723	97.6%	0.6	37.7	3.4	D
EB	Left Turn							
	Through	560	498	88.9%	2.7	99.4	4.6	F
	Right Turn	170	155	90.9%	1.2	59.2	4.5	E
	Subtotal	730	652	89.4%	3.0	89.9	3.9	F
WB	Left Turn	330	342	103.6%	0.7	7.1	3.3	A
	Through	680	691	101.6%	0.4	3.3	0.7	A
	Right Turn							
	Subtotal	1010	1033	102.3%	0.7	4.6	1.5	A
Total		3260	3193	97.9%	1.2	46.6	1.4	D

SimTraffic Post-Processor
Average Results from 20 Runs
Volume and Delay by Movement

Caltrain Electrification
2020 Plus Project Conditions
PM Peak Hour

Intersection **Curtiss Street/Hillsdale Blvd**

Signalized

Direction	Movement	Volume (veh/hr)			GEH	Total Delay (sec/veh)		
		Demand	Served	% Served		Average	Std. Dev.	LOS
NB	Left Turn	50	49	98.6%	0.1	43.5	3.6	D
	Through	30	28	94.3%	0.3	45.4	8.2	D
	Right Turn	60	61	100.8%	0.1	18.4	2.3	B
	Subtotal	140	138	98.6%	0.2	32.7	2.6	C
SB	Left Turn	40	38	96.0%	0.3	45.1	5.9	D
	Through	10	12	121.0%	0.6	37.9	9.5	D
	Right Turn	10	11	111.0%	0.3	20.5	7.5	C
	Subtotal	60	62	102.7%	0.2	39.6	3.8	D
EB	Left Turn	10	10	96.0%	0.1	29.9	9.6	C
	Through	1350	1295	95.9%	1.5	6.1	1.6	A
	Right Turn	80	76	95.4%	0.4	5.5	1.5	A
	Subtotal	1440	1381	95.9%	1.6	6.3	1.6	A
WB	Left Turn	10	10	100.0%	0.0	32.1	11.2	C
	Through	1420	1419	99.9%	0.0	10.5	1.2	B
	Right Turn	40	38	95.8%	0.3	8.5	2.0	A
	Subtotal	1470	1467	99.8%	0.1	10.6	1.2	B
Total		3110	3047	98.0%	1.1	10.2	0.8	B

SimTraffic Post-Processor
Average Results from 20 Runs
Volume and Delay by Movement

Caltrain Electrification
2020 Plus Project Conditions
PM Peak Hour

Intersection

El Camino Real/Ralston Avenue

Signalized

Direction	Movement	Volume (veh/hr)			GEH	Total Delay (sec/veh)		
		Demand	Served	% Served		Average	Std. Dev.	LOS
NB	Left Turn	210	181	86.2%	2.1	232.8	12.1	F
	Through	960	816	85.0%	4.8	207.0	6.8	F
	Right Turn	230	207	90.1%	1.5	29.3	2.2	C
	Subtotal	1400	1204	86.0%	5.4	180.4	5.7	F
SB	Left Turn	340	305	89.8%	1.9	213.0	20.8	F
	Through	1130	1058	93.6%	2.2	105.6	9.7	F
	Right Turn	140	137	97.6%	0.3	65.7	10.8	E
	Subtotal	1610	1500	93.2%	2.8	123.9	7.1	F
EB	Left Turn	280	251	89.6%	1.8	210.6	18.1	F
	Through	620	563	90.8%	2.3	240.8	23.4	F
	Right Turn	80	78	97.1%	0.3	265.4	28.3	F
	Subtotal	980	892	91.0%	2.9	234.5	22.4	F
WB	Left Turn	270	270	100.1%	0.0	51.9	6.3	D
	Through	670	665	99.2%	0.2	105.5	30.9	F
	Right Turn	440	444	101.0%	0.2	68.6	28.9	E
	Subtotal	1380	1379	99.9%	0.0	83.2	16.5	F
Total		5370	4975	92.6%	5.5	146.1	4.4	F

SimTraffic Post-Processor
Average Results from 20 Runs
Volume and Delay by Movement

Caltrain Electrification
2020 Plus Project Conditions
PM Peak Hour

Intersection

El Camino Real/San Carlos Avenue-Caltrain Station

Signalized

Direction	Movement	Volume (veh/hr)			GEH	Total Delay (sec/veh)		
		Demand	Served	% Served		Average	Std. Dev.	LOS
NB	Left Turn	220	213	96.9%	0.5	132.2	30.2	F
	Through	1060	1047	98.8%	0.4	26.5	2.4	C
	Right Turn	20	24	118.5%	0.8	27.0	4.8	C
	Subtotal	1300	1284	98.7%	0.5	44.0	6.1	D
SB	Left Turn	40	39	98.5%	0.1	63.6	9.0	E
	Through	940	933	99.3%	0.2	57.2	8.5	E
	Right Turn	410	403	98.3%	0.3	33.6	6.8	C
	Subtotal	1390	1376	99.0%	0.4	50.5	8.1	D
EB	Left Turn	390	381	97.7%	0.5	22.8	1.8	C
	Through	70	73	104.4%	0.4	24.1	2.5	C
	Right Turn	170	175	102.9%	0.4	19.0	1.2	B
	Subtotal	630	629	99.9%	0.0	21.9	1.4	C
WB	Left Turn	10	9	89.0%	0.4	45.8	9.7	D
	Through	20	20	100.0%	0.0	41.3	4.3	D
	Right Turn	30	29	97.0%	0.2	16.3	5.0	B
	Subtotal	60	58	96.7%	0.3	29.4	3.8	C
Total		3380	3347	99.0%	0.6	42.3	3.4	D

SimTraffic Post-Processor
Average Results from 20 Runs
Volume and Delay by Movement

Caltrain Electrification
2020 Plus Project Conditions
PM Peak Hour

Intersection California/Broadway

Unsignalized

Direction	Movement	Volume (veh/hr)			GEH	Total Delay (sec/veh)		
		Demand	Served	% Served		Average	Std. Dev.	LOS
NB	Left Turn	20	19	92.5%	0.3	209.0	95.9	F
	Through	40	39	97.3%	0.2	203.5	101.8	F
	Right Turn	70	64	90.9%	0.8	189.8	100.5	F
	Subtotal	130	121	93.1%	0.8	196.3	98.0	F
SB	Left Turn	30	26	86.7%	0.8	375.8	178.3	F
	Through	60	53	88.5%	0.9	365.5	184.7	F
	Right Turn	70	60	85.0%	1.3	366.0	201.7	F
	Subtotal	160	139	86.6%	1.8	366.8	190.1	F
EB	Left Turn	40	16	39.8%	4.6	734.2	603.0	F
	Through	530	227	42.8%	15.6	518.4	103.9	F
	Right Turn	90	39	43.6%	6.3	467.8	115.6	F
	Subtotal	660	282	42.7%	17.4	515.2	101.4	F
WB	Left Turn	160	86	53.9%	6.7	8.6	1.1	A
	Through	660	366	55.4%	13.0	3.4	0.4	A
	Right Turn	50	28	56.4%	3.5	0.4	0.2	A
	Subtotal	870	480	55.2%	15.0	4.1	0.5	A
Total		1820	1022	56.1%	21.2	215.2	36.8	F

Intersection Arguello Street/Brewster Ave

Signalized

Direction	Movement	Volume (veh/hr)			GEH	Total Delay (sec/veh)		
		Demand	Served	% Served		Average	Std. Dev.	LOS
NB	Left Turn	100	61	61.3%	4.3	82.4	20.8	F
	Through	250	161	64.4%	6.2	63.0	16.7	E
	Right Turn	70	45	63.9%	3.3	37.7	60.7	D
	Subtotal	420	267	63.5%	8.3	62.8	22.2	E
SB	Left Turn	30	25	83.7%	0.9	401.5	217.4	F
	Through	150	146	97.5%	0.3	369.8	157.7	F
	Right Turn	130	125	96.4%	0.4	357.2	157.5	F
	Subtotal	310	297	95.7%	0.8	366.8	161.6	F
EB	Left Turn	110	82	74.7%	2.8	12.7	3.6	B
	Through	180	146	80.8%	2.7	14.6	4.8	B
	Right Turn	60	48	80.2%	1.6	2.4	0.7	A
	Subtotal	350	276	78.8%	4.2	11.8	2.2	B
WB	Left Turn	50	46	92.6%	0.5	53.2	10.4	D
	Through	400	407	101.7%	0.3	54.1	9.7	D
	Right Turn	50	52	103.2%	0.2	45.3	9.1	D
	Subtotal	500	505	100.9%	0.2	53.1	9.4	D
Total		1580	1344	85.1%	6.2	115.3	36.1	F

SimTraffic Post-Processor
Average Results from 20 Runs
Volume and Delay by Movement

Caltrain Electrification
2020 Plus Project Conditions
PM Peak Hour

Intersection

El Camino Real/Broadway

Signalized

Direction	Movement	Volume (veh/hr)			GEH	Total Delay (sec/veh)		
		Demand	Served	% Served		Average	Std. Dev.	LOS
NB	Left Turn	210	192	91.3%	1.3	178.8	47.7	F
	Through	1250	1169	93.6%	2.3	72.6	4.5	E
	Right Turn	100	92	91.6%	0.9	172.5	40.0	F
	Subtotal	1560	1453	93.1%	2.8	93.2	8.7	F
SB	Left Turn	210	79	37.4%	10.9	707.6	153.7	F
	Through	1150	527	45.8%	21.5	28.0	2.8	C
	Right Turn	20	11	53.0%	2.4	11.6	5.5	B
	Subtotal	1380	616	44.6%	24.2	114.8	23.2	F
EB	Left Turn	20	8	41.0%	3.1	566.7	149.1	F
	Through	310	107	34.6%	14.0	529.6	78.4	F
	Right Turn	260	80	30.6%	13.8	421.1	71.4	F
	Subtotal	590	195	33.1%	19.9	486.7	78.9	F
WB	Left Turn	200	119	59.4%	6.4	37.8	7.7	D
	Through	290	218	75.1%	4.5	22.6	2.1	C
	Right Turn	190	106	55.9%	6.9	22.7	3.4	C
	Subtotal	680	443	65.1%	10.0	26.8	3.8	C
Total		4210	2706	64.3%	25.6	114.1	6.7	F

Intersection

Arguello St/Broadway

Signalized

Direction	Movement	Volume (veh/hr)			GEH	Total Delay (sec/veh)		
		Demand	Served	% Served		Average	Std. Dev.	LOS
NB	Left Turn	50	41	82.6%	1.3	137.4	31.4	F
	Through	140	136	97.4%	0.3	127.0	23.9	F
	Right Turn	220	197	89.7%	1.6	112.0	19.5	F
	Subtotal	410	375	91.5%	1.8	120.3	21.5	F
SB	Left Turn	30	27	89.7%	0.6	38.6	7.4	D
	Through	160	151	94.2%	0.7	34.6	4.6	C
	Right Turn	70	66	93.6%	0.5	28.4	4.4	C
	Subtotal	260	243	93.5%	1.1	33.4	4.2	C
EB	Left Turn	180	86	47.9%	8.1	17.0	3.3	B
	Through	300	156	51.8%	9.6	9.5	1.6	A
	Right Turn	150	78	51.9%	6.8	1.6	0.3	A
	Subtotal	630	320	50.7%	14.2	9.6	1.6	A
WB	Left Turn	20	9	44.5%	2.9	181.3	55.4	F
	Through	750	370	49.4%	16.0	140.6	21.3	F
	Right Turn	100	47	47.3%	6.1	81.9	13.1	F
	Subtotal	870	427	49.0%	17.4	134.8	20.2	F
Total		2170	1364	62.9%	19.2	82.7	4.8	F

SimTraffic Post-Processor
Average Results from 20 Runs
Volume and Delay by Movement

Caltrain Electrification
2020 Plus Project Conditions
PM Peak Hour

Intersection

El Camino Real/James

Signalized

Direction	Movement	Volume (veh/hr)			GEH	Total Delay (sec/veh)		
		Demand	Served	% Served		Average	Std. Dev.	LOS
NB	Left Turn	137	120	87.5%	1.5	178.4	65.1	F
	Through	1474	1316	89.3%	4.2	154.3	68.4	F
	Right Turn	42	36	86.2%	0.9	105.4	68.0	F
	Subtotal	1653	1472	89.1%	4.6	155.1	68.1	F
SB	Left Turn	126	49	38.7%	8.3	40.1	6.6	D
	Through	1484	651	43.9%	25.5	13.4	1.8	B
	Right Turn	84	37	44.5%	6.0	4.8	1.0	A
	Subtotal	1694	737	43.5%	27.4	14.7	1.8	B
EB	Left Turn	95	88	92.5%	0.7	36.3	1.9	D
	Through	211	199	94.1%	0.9	28.0	1.0	C
	Right Turn	105	104	98.8%	0.1	13.4	1.2	B
	Subtotal	411	390	94.9%	1.0	26.0	0.9	C
WB	Left Turn	116	70	60.1%	4.8	35.5	4.2	D
	Through	84	71	84.3%	1.5	16.4	2.7	B
	Right Turn	74	40	53.9%	4.5	22.4	3.2	C
	Subtotal	274	180	65.8%	6.2	25.1	2.6	C
Total		4032	2780	68.9%	21.5	91.1	35.6	F

Intersection

El Camino Real/Atherton Avenue-Fair Oaks Lane

Signalized

Direction	Movement	Volume (veh/hr)			GEH	Total Delay (sec/veh)		
		Demand	Served	% Served		Average	Std. Dev.	LOS
NB	Left Turn	230	217	94.4%	0.9	140.9	82.4	F
	Through	1820	1782	97.9%	0.9	24.0	3.6	C
	Right Turn	80	82	102.8%	0.2	26.9	4.7	C
	Subtotal	2130	2081	97.7%	1.1	36.4	11.1	D
SB	Left Turn	40	42	106.0%	0.4	45.7	5.1	D
	Through	1220	1221	100.1%	0.0	26.5	1.5	C
	Right Turn	80	81	101.4%	0.1	28.2	3.5	C
	Subtotal	1340	1345	100.4%	0.1	27.2	1.6	C
EB	Left Turn	130	136	104.8%	0.5	37.3	4.1	D
	Through	90	90	100.3%	0.0	33.9	5.3	C
	Right Turn	70	66	94.6%	0.5	19.7	4.4	B
	Subtotal	290	293	100.9%	0.2	32.3	3.9	C
WB	Left Turn	40	37	92.5%	0.5	55.6	9.1	E
	Through	110	109	98.6%	0.1	56.1	9.5	E
	Right Turn	70	74	105.4%	0.4	24.3	9.2	C
	Subtotal	220	219	99.7%	0.0	45.4	9.4	D
Total		3980	3938	98.9%	0.7	33.5	6.4	C

Intersection

El Camino Real/Watkins Avenue

Unsignalized

Direction	Movement	Volume (veh/hr)			GEH	Total Delay (sec/veh)		
		Demand	Served	% Served		Average	Std. Dev.	LOS
NB	Left Turn							
	Through	2030	2028	99.9%	0.0	2.3	0.1	A
	Right Turn	50	56	112.4%	0.9	3.3	0.4	A
	Subtotal	2080	2084	100.2%	0.1	2.3	0.1	A
SB	Left Turn	30	30	101.0%	0.1	31.4	10.5	D
	Through	1300	1296	99.7%	0.1	4.2	0.1	A
	Right Turn							
	Subtotal	1330	1326	99.7%	0.1	4.9	0.3	A
EB	Left Turn							
	Through							
	Right Turn							
	Subtotal							
WB	Left Turn	50	24	48.2%	4.3	1371.7	407.8	F
	Through							
	Right Turn	100	53	52.7%	5.4	1261.2	334.7	F
	Subtotal	150	77	51.2%	6.9	1297.3	350.2	F
Total		3560	3487	98.0%	1.2	30.8	4.8	D

Intersection El Camino Real/Glenwood

Signalized

Direction	Movement	Volume (veh/hr)			GEH	Total Delay (sec/veh)		
		Demand	Served	% Served		Average	Std. Dev.	LOS
NB	Left Turn	140	140	100.3%	0.0	63.0	8.4	E
	Through	1570	1391	88.6%	4.7	27.3	2.5	C
	Right Turn	70	67	96.0%	0.3	19.7	2.8	B
	Subtotal	1780	1598	89.8%	4.4	30.1	2.6	C
SB	Left Turn	40	33	82.0%	1.2	75.1	10.8	E
	Through	1050	1045	99.6%	0.1	34.3	7.0	C
	Right Turn	270	274	101.5%	0.2	8.7	2.7	A
	Subtotal	1360	1352	99.4%	0.2	30.1	6.2	C
EB	Left Turn	320	304	95.0%	0.9	258.8	109.6	F
	Through	130	123	94.5%	0.6	263.2	107.7	F
	Right Turn	110	111	101.3%	0.1	206.8	102.3	F
	Subtotal	560	538	96.1%	0.9	249.0	107.6	F
WB	Left Turn	90	71	79.3%	2.1	646.7	197.1	F
	Through	170	140	82.6%	2.4	656.2	186.1	F
	Right Turn	130	105	80.8%	2.3	618.8	182.5	F
	Subtotal	390	317	81.3%	3.9	641.1	185.7	F
Total		4090	3806	93.0%	4.5	111.8	22.6	F

Intersection El Camino Real/Oak Grove

Signalized

Direction	Movement	Volume (veh/hr)			GEH	Total Delay (sec/veh)		
		Demand	Served	% Served		Average	Std. Dev.	LOS
NB	Left Turn	130	111	85.5%	1.7	42.7	4.4	D
	Through	1560	1381	88.5%	4.7	17.5	1.8	B
	Right Turn	130	113	87.2%	1.5	9.7	2.6	A
	Subtotal	1820	1606	88.2%	5.2	18.7	1.9	B
SB	Left Turn	140	136	97.0%	0.4	55.7	20.7	E
	Through	990	965	97.5%	0.8	36.6	25.7	D
	Right Turn	120	117	97.8%	0.2	28.8	22.2	C
	Subtotal	1250	1218	97.5%	0.9	37.9	24.4	D
EB	Left Turn	120	115	96.2%	0.4	100.4	24.9	F
	Through	220	211	96.0%	0.6	114.2	30.4	F
	Right Turn	140	144	102.6%	0.3	77.3	30.7	E
	Subtotal	480	470	98.0%	0.4	99.4	28.5	F
WB	Left Turn	110	103	93.6%	0.7	89.2	23.3	F
	Through	190	182	95.7%	0.6	66.0	9.1	E
	Right Turn	100	98	98.1%	0.2	36.5	11.6	D
	Subtotal	400	383	95.7%	0.9	64.9	13.7	E
Total		3950	3677	93.1%	4.4	40.1	12.6	D

Intersection El Camino Real/Santa Cruz Ave

Signalized

Direction	Movement	Volume (veh/hr)			GEH	Total Delay (sec/veh)		
		Demand	Served	% Served		Average	Std. Dev.	LOS
NB	Left Turn							
	Through	1480	1282	86.6%	5.3	5.2	0.6	A
	Right Turn	80	72	89.4%	1.0	4.1	2.6	A
	Subtotal	1560	1353	86.7%	5.4	5.1	0.6	A
SB	Left Turn							
	Through	1140	1100	96.5%	1.2	35.7	13.5	D
	Right Turn	100	104	103.6%	0.4	17.1	7.6	B
	Subtotal	1240	1204	97.1%	1.0	34.1	13.1	C
EB	Left Turn	180	183	101.7%	0.2	53.5	3.5	D
	Through	100	102	102.2%	0.2	51.7	9.6	D
	Right Turn	170	172	101.1%	0.1	31.3	5.9	C
	Subtotal	450	457	101.6%	0.3	44.9	3.7	D
WB	Left Turn	80	67	83.8%	1.5	77.5	6.5	E
	Through	180	147	81.8%	2.6	98.5	6.3	F
	Right Turn	160	129	80.3%	2.6	82.8	6.0	F
	Subtotal	420	343	81.6%	4.0	88.5	6.2	F
Total		3670	3357	91.5%	5.3	29.4	4.6	C

Intersection Merril St/Santa Cruz Ave

Unsignalized

Direction	Movement	Volume (veh/hr)			GEH	Total Delay (sec/veh)		
		Demand	Served	% Served		Average	Std. Dev.	LOS
NB	Left Turn	280	207	74.0%	4.7	82.3	8.8	F
	Through	20	13	64.0%	1.8	86.1	62.5	F
	Right Turn	10	8	82.0%	0.6	66.7	13.0	F
	Subtotal	310	228	73.6%	5.0	81.2	9.2	F
SB	Left Turn	10	10	98.0%	0.1	214.0	91.6	F
	Through	130	113	86.8%	1.6	204.7	58.5	F
	Right Turn	110	104	94.6%	0.6	209.0	62.1	F
	Subtotal	250	227	90.7%	1.5	206.8	60.0	F
EB	Left Turn	110	105	95.8%	0.4	28.2	10.4	D
	Through	40	41	102.8%	0.2	33.4	9.1	D
	Right Turn	30	29	96.3%	0.2	26.5	17.9	D
	Subtotal	180	175	97.4%	0.3	29.1	10.9	D
WB	Left Turn	10	11	107.0%	0.2	24.7	10.3	C
	Through	30	28	91.7%	0.5	43.7	6.9	E
	Right Turn	30	33	108.7%	0.5	22.8	11.6	C
	Subtotal	70	71	101.1%	0.1	30.9	8.5	D
Total		810	701	86.6%	4.0	104.0	21.5	F

SimTraffic Post-Processor
Average Results from 20 Runs
Volume and Delay by Movement

Caltrain Electrification
2020 Plus Project Conditions
PM Peak Hour

Intersection Ravenswood Ave/Laurel St

Signalized

Direction	Movement	Volume (veh/hr)			GEH	Total Delay (sec/veh)		
		Demand	Served	% Served		Average	Std. Dev.	LOS
NB	Left Turn	190	187	98.6%	0.2	64.8	22.9	E
	Through	140	137	98.1%	0.2	36.7	14.5	D
	Right Turn	50	52	104.0%	0.3	35.2	20.5	D
	Subtotal	380	377	99.1%	0.2	50.5	19.4	D
SB	Left Turn	60	62	102.5%	0.2	62.0	22.5	E
	Through	130	135	104.0%	0.5	58.4	16.4	E
	Right Turn	80	80	100.5%	0.0	49.7	23.1	D
	Subtotal	270	277	102.6%	0.4	56.7	19.4	E
EB	Left Turn	80	66	83.0%	1.6	91.8	26.9	F
	Through	850	700	82.3%	5.4	28.1	3.9	C
	Right Turn	130	112	86.5%	1.6	25.4	5.3	C
	Subtotal	1060	878	82.9%	5.8	32.6	4.3	C
WB	Left Turn	40	39	97.8%	0.1	101.5	55.7	F
	Through	590	575	97.4%	0.6	66.1	44.8	E
	Right Turn	160	163	102.1%	0.3	63.6	45.8	E
	Subtotal	790	777	98.4%	0.5	67.4	45.3	E
Total		2500	2309	92.4%	3.9	50.1	19.8	D

Intersection

High Street/University Ave

Signalized

Direction	Movement	Volume (veh/hr)			GEH	Total Delay (sec/veh)		
		Demand	Served	% Served		Average	Std. Dev.	LOS
NB	Left Turn							
	Through							
	Right Turn							
	Subtotal							
SB	Left Turn	30	28	93.0%	0.4	19.2	4.8	B
	Through	100	105	104.7%	0.5	12.1	1.6	B
	Right Turn	220	231	104.8%	0.7	12.4	0.7	B
	Subtotal	350	363	103.7%	0.7	12.8	1.2	B
EB	Left Turn							
	Through	660	662	100.4%	0.1	16.4	1.4	B
	Right Turn	440	441	100.2%	0.0	7.1	0.9	A
	Subtotal	1100	1103	100.3%	0.1	12.7	0.9	B
WB	Left Turn	30	27	91.0%	0.5	49.7	9.1	D
	Through	550	511	92.9%	1.7	33.3	3.2	C
	Right Turn							
	Subtotal	580	539	92.8%	1.8	34.2	3.4	C
Total		2030	2005	98.8%	0.6	18.4	0.8	B

Intersection

Showers Drive/Pacchetti Way

Signalized

Direction	Movement	Volume (veh/hr)			GEH	Total Delay (sec/veh)		
		Demand	Served	% Served		Average	Std. Dev.	LOS
NB	Left Turn	10	7	74.0%	0.9	24.7	5.6	C
	Through	30	32	106.3%	0.3	2.6	0.8	A
	Right Turn							
	Subtotal	40	39	98.3%	0.1	6.6	1.3	A
SB	Left Turn							
	Through	190	177	93.4%	0.9	4.8	0.6	A
	Right Turn	50	53	105.4%	0.4	2.6	0.7	A
	Subtotal	240	230	95.9%	0.6	4.3	0.6	A
EB	Left Turn	30	28	94.0%	0.3	13.0	2.0	B
	Through							
	Right Turn	10	11	108.0%	0.2	3.4	0.8	A
	Subtotal	40	39	97.5%	0.2	10.4	1.4	B
WB	Left Turn							
	Through							
	Right Turn							
	Subtotal							
Total		320	308	96.4%	0.7	5.3	0.4	A

SimTraffic Post-Processor
Average Results from 20 Runs
Volume and Delay by Movement

Caltrain Electrification
2020 Plus Project Conditions
PM Peak Hour

Intersection Hope Street/Evelyn Ave

Signalized

Direction	Movement	Volume (veh/hr)			GEH	Total Delay (sec/veh)		
		Demand	Served	% Served		Average	Std. Dev.	LOS
NB	Left Turn	110	105	95.0%	0.5	19.0	1.7	B
	Through							
	Right Turn	180	188	104.5%	0.6	5.6	0.2	A
	Subtotal	290	293	100.9%	0.2	10.4	1.0	B
SB	Left Turn							
	Through							
	Right Turn							
	Subtotal							
EB	Left Turn							
	Through	50	49	97.2%	0.2	1.9	0.3	A
	Right Turn	50	51	101.2%	0.1	1.1	0.2	A
	Subtotal	100	99	99.2%	0.1	1.5	0.2	A
WB	Left Turn	80	76	95.5%	0.4	2.8	0.7	A
	Through	190	195	102.4%	0.3	2.4	0.7	A
	Right Turn							
	Subtotal	270	271	100.3%	0.1	2.5	0.4	A
Total		660	663	100.4%	0.1	5.8	0.6	A

Intersection Castro Street/Villa Street

Signalized

Direction	Movement	Volume (veh/hr)			GEH	Total Delay (sec/veh)		
		Demand	Served	% Served		Average	Std. Dev.	LOS
NB	Left Turn	40	42	103.8%	0.2	55.0	11.4	D
	Through	250	250	99.8%	0.0	43.3	6.5	D
	Right Turn	50	51	101.0%	0.1	33.8	4.6	C
	Subtotal	340	342	100.4%	0.1	43.3	6.4	D
SB	Left Turn	250	231	92.2%	1.3	83.9	4.4	F
	Through	260	248	95.5%	0.7	28.4	1.9	C
	Right Turn	130	121	92.7%	0.8	23.2	1.8	C
	Subtotal	640	600	93.7%	1.6	48.8	3.0	D
EB	Left Turn	250	223	89.0%	1.8	146.9	16.7	F
	Through	250	211	84.3%	2.6	144.7	17.4	F
	Right Turn	40	37	91.3%	0.6	137.6	19.3	F
	Subtotal	540	470	87.0%	3.1	145.1	16.9	F
WB	Left Turn	30	30	99.7%	0.0	28.7	7.3	C
	Through	220	217	98.5%	0.2	20.9	2.5	C
	Right Turn	70	73	104.0%	0.3	15.9	2.6	B
	Subtotal	320	319	99.8%	0.0	20.5	2.6	C
Total		1840	1730	94.0%	2.6	68.5	4.8	E

SimTraffic Post-Processor
Average Results from 20 Runs
Volume and Delay by Movement

Caltrain Electrification
2020 Plus Project Conditions
PM Peak Hour

Intersection

Frances St/Evelyn Ave

Signalized

Direction	Movement	Volume (veh/hr)			GEH	Total Delay (sec/veh)		
		Demand	Served	% Served		Average	Std. Dev.	LOS
NB	Left Turn	30	30	98.3%	0.1	29.5	5.0	C
	Through	50	50	100.4%	0.0	25.2	3.9	C
	Right Turn	20	18	90.0%	0.5	16.4	3.9	B
	Subtotal	100	98	97.7%	0.2	24.8	3.3	C
SB	Left Turn	160	156	97.3%	0.3	59.1	24.8	E
	Through	40	39	97.8%	0.1	55.0	22.0	D
	Right Turn	100	103	102.8%	0.3	45.9	21.3	D
	Subtotal	300	298	99.2%	0.1	54.0	23.3	D
EB	Left Turn	100	94	94.0%	0.6	108.1	20.4	F
	Through	520	524	100.7%	0.2	35.8	5.9	D
	Right Turn	70	67	95.0%	0.4	31.1	7.8	C
	Subtotal	690	684	99.2%	0.2	45.4	6.2	D
WB	Left Turn	80	78	97.5%	0.2	62.7	8.7	E
	Through	370	404	109.1%	1.7	17.6	2.3	B
	Right Turn	170	162	95.3%	0.6	8.7	3.1	A
	Subtotal	620	644	103.8%	0.9	20.8	3.2	C
Total		1710	1723	100.8%	0.3	36.6	4.1	D

Intersection Lawrence Expressway/Kifer Road

Signalized

Direction	Movement	Volume (veh/hr)			GEH	Total Delay (sec/veh)		
		Demand	Served	% Served		Average	Std. Dev.	LOS
NB	Left Turn	110	108	98.1%	0.2	130.2	17.7	F
	Through	2040	2104	103.2%	1.4	116.3	31.2	F
	Right Turn	290	289	99.7%	0.1	154.0	37.6	F
	Subtotal	2440	2501	102.5%	1.2	121.3	31.2	F
SB	Left Turn	470	277	58.9%	10.0	453.3	59.7	F
	Through	3460	2264	65.4%	22.3	150.6	18.5	F
	Right Turn	50	36	71.6%	2.2	165.9	39.0	F
	Subtotal	3980	2577	64.7%	24.5	183.6	10.6	F
EB	Left Turn	280	218	78.0%	3.9	75.8	12.5	E
	Through	590	466	79.0%	5.4	37.7	1.7	D
	Right Turn	1120	849	75.8%	8.6	222.8	7.5	F
	Subtotal	1990	1534	77.1%	10.9	145.6	4.9	F
WB	Left Turn	640	355	55.5%	12.8	974.0	61.1	F
	Through	930	559	60.1%	13.6	73.4	6.7	E
	Right Turn	240	147	61.2%	6.7	62.6	11.0	E
	Subtotal	1810	1061	58.6%	19.8	376.0	35.3	F
Total		10220	7673	75.1%	26.9	181.7	10.8	F

Intersection Lawrence Expressway/Reed Ave-Monroe St

Signalized

Direction	Movement	Volume (veh/hr)			GEH	Total Delay (sec/veh)		
		Demand	Served	% Served		Average	Std. Dev.	LOS
NB	Left Turn	150	140	93.2%	0.8	279.9	119.8	F
	Through	2040	2064	101.2%	0.5	45.7	3.3	D
	Right Turn	400	391	97.7%	0.5	21.1	3.4	C
	Subtotal	2590	2595	100.2%	0.1	54.7	8.8	D
SB	Left Turn	670	441	65.9%	9.7	70.1	5.3	E
	Through	4180	2791	66.8%	23.5	41.1	4.4	D
	Right Turn	370	245	66.1%	7.2	28.0	3.1	C
	Subtotal	5220	3477	66.6%	26.4	43.9	4.2	D
EB	Left Turn	300	295	98.3%	0.3	105.8	34.0	F
	Through	650	640	98.4%	0.4	142.0	47.9	F
	Right Turn	420	410	97.6%	0.5	36.2	31.4	D
	Subtotal	1370	1345	98.2%	0.7	101.9	38.8	F
WB	Left Turn	400	373	93.3%	1.4	227.5	67.4	F
	Through	350	344	98.1%	0.3	123.4	35.8	F
	Right Turn	100	97	97.1%	0.3	21.9	16.5	C
	Subtotal	850	814	95.8%	1.3	159.2	47.4	F
Total		10030	8231	82.1%	18.8	68.1	7.1	E

Intersection

El Camino Real/Railroad Avenue

Signalized

Direction	Movement	Volume (veh/hr)			GEH	Total Delay (sec/veh)		
		Demand	Served	% Served		Average	Std. Dev.	LOS
NB	Left Turn	190	190	99.9%	0.0	45.5	5.9	D
	Through	770	770	99.9%	0.0	14.3	0.8	B
	Right Turn	30	29	96.7%	0.2	13.1	2.7	B
	Subtotal	990	989	99.8%	0.0	20.3	1.3	C
SB	Left Turn	110	109	99.0%	0.1	39.6	3.0	D
	Through	1310	1322	100.9%	0.3	22.3	0.5	C
	Right Turn	180	170	94.2%	0.8	25.9	1.2	C
	Subtotal	1600	1601	100.1%	0.0	23.9	0.4	C
EB	Left Turn	60	61	101.7%	0.1	28.2	2.6	C
	Through	10	9	90.0%	0.3	19.6	6.3	B
	Right Turn	140	137	97.9%	0.2	12.3	1.0	B
	Subtotal	210	207	98.6%	0.2	17.2	1.1	B
WB	Left Turn	100	102	102.0%	0.2	30.2	1.6	C
	Through	10	10	98.0%	0.1	19.3	4.7	B
	Right Turn	40	44	109.5%	0.6	6.0	1.1	A
	Subtotal	150	156	103.7%	0.5	22.6	1.0	C
Total		2950	2952	100.1%	0.0	22.1	0.4	C

Intersection Santa Clara Street/Cahill Street

Signalized

Direction	Movement	Volume (veh/hr)			GEH	Total Delay (sec/veh)		
		Demand	Served	% Served		Average	Std. Dev.	LOS
NB	Left Turn	130	98	75.4%	3.0	34.5	4.3	C
	Through	10	12	120.0%	0.6	17.6	6.0	B
	Right Turn	180	140	78.0%	3.1	26.5	3.5	C
	Subtotal	320	250	78.3%	4.1	29.3	2.4	C
SB	Left Turn	10	8	79.0%	0.7	50.3	7.7	D
	Through	10	10	98.0%	0.1	46.4	9.9	D
	Right Turn	10	11	105.0%	0.2	10.8	8.3	B
	Subtotal	30	28	94.0%	0.3	34.0	4.4	C
EB	Left Turn							
	Through	1110	861	77.6%	7.9	109.5	14.0	F
	Right Turn	150	117	78.3%	2.8	124.5	19.7	F
	Subtotal	1260	979	77.7%	8.4	111.3	14.1	F
WB	Left Turn	200	148	74.2%	3.9	54.7	4.0	D
	Through	780	610	78.2%	6.5	3.5	0.8	A
	Right Turn	10	9	92.0%	0.3	1.8	2.3	A
	Subtotal	990	767	77.5%	7.5	13.4	1.3	B
Total		2600	2025	77.9%	12.0	62.8	5.7	E

Intersection San Fernando Street/Montgomery Street

Signalized

Direction	Movement	Volume (veh/hr)			GEH	Total Delay (sec/veh)		
		Demand	Served	% Served		Average	Std. Dev.	LOS
NB	Left Turn							
	Through							
	Right Turn							
	Subtotal							
SB	Left Turn	100	71	70.7%	3.2	166.7	34.5	F
	Through	1540	1219	79.1%	8.7	185.6	20.8	F
	Right Turn	30	22	74.3%	1.5	186.6	52.3	F
	Subtotal	1670	1312	78.5%	9.3	184.6	19.9	F
EB	Left Turn							
	Through	240	218	90.8%	1.5	31.6	3.0	C
	Right Turn	250	209	83.8%	2.7	33.0	3.3	C
	Subtotal	490	427	87.2%	2.9	32.3	2.7	C
WB	Left Turn	120	85	70.8%	3.5	207.1	57.3	F
	Through	370	287	77.6%	4.6	212.1	31.1	F
	Right Turn							
	Subtotal	490	372	76.0%	5.7	210.6	29.4	F
Total		2650	2111	79.7%	11.0	158.1	14.3	F

SimTraffic Post-Processor
Average Results from 20 Runs
Volume and Delay by Movement

Caltrain Electrification
2020 Plus Project Conditions
PM Peak Hour

Intersection

Lick Avenue-Shadow Run Drive/Alma Avenue

Signalized

Direction	Movement	Volume (veh/hr)			GEH	Total Delay (sec/veh)		
		Demand	Served	% Served		Average	Std. Dev.	LOS
NB	Left Turn	30	27	91.3%	0.5	30.1	4.5	C
	Through	10	11	107.0%	0.2	29.6	7.9	C
	Right Turn	50	49	97.2%	0.2	8.9	2.2	A
	Subtotal	90	87	96.3%	0.4	18.3	3.2	B
SB	Left Turn	290	390	134.4%	5.4	118.3	2.6	F
	Through	40	45	113.5%	0.8	71.9	4.4	E
	Right Turn	80	117	146.5%	3.7	56.8	2.3	E
	Subtotal	410	552	134.7%	6.5	101.5	2.7	F
EB	Left Turn	60	83	138.2%	2.7	34.2	1.7	C
	Through	650	679	104.4%	1.1	19.8	0.9	B
	Right Turn	40	38	95.3%	0.3	17.5	3.6	B
	Subtotal	750	800	106.7%	1.8	21.2	0.9	C
WB	Left Turn	20	18	89.0%	0.5	45.7	7.6	D
	Through	670	658	98.2%	0.5	33.7	3.2	C
	Right Turn	60	85	141.3%	2.9	33.0	5.2	C
	Subtotal	750	760	101.4%	0.4	33.9	3.3	C
Total		2000	2199	110.0%	4.4	45.6	1.1	D

SimTraffic Post-Processor
Average Results from 20 Runs
Volume and Delay by Movement

Caltrain Electrification
2020 Plus Project Conditions
PM Peak Hour

Intersection 7th Street/Mission Bay

Signalized

Direction	Movement	Volume (veh/hr)			GEH	Total Delay (sec/veh)		
		Demand	Served	% Served		Average	Std. Dev.	LOS
NB	Left Turn	10	10	98.0%	0.1	22.7	9.7	C
	Through	1120	1117	99.8%	0.1	10.9	0.8	B
	Right Turn	70	72	103.1%	0.3	19.2	3.5	B
	Subtotal	1200	1199	99.9%	0.0	11.4	0.7	B
SB	Left Turn	100	96	96.1%	0.4	95.7	7.8	F
	Through	290	292	100.7%	0.1	4.9	0.8	A
	Right Turn	10	11	109.0%	0.3	2.2	0.7	A
	Subtotal	400	399	99.8%	0.0	26.6	1.6	C
EB	Left Turn							
	Through							
	Right Turn							
	Subtotal							
WB	Left Turn	30	28	92.7%	0.4	2.5	3.8	A
	Through							
	Right Turn	80	86	107.8%	0.7	0.8	0.4	A
	Subtotal	110	114	103.6%	0.4	1.2	0.9	A
Total		1710	1712	100.1%	0.1	14.3	0.8	B

Intersection Berry Street/Mission Bay

Signalized

Direction	Movement	Volume (veh/hr)			GEH	Total Delay (sec/veh)		
		Demand	Served	% Served		Average	Std. Dev.	LOS
NB	Left Turn							
	Through							
	Right Turn							
	Subtotal							
SB	Left Turn							
	Through							
	Right Turn	110	113	102.3%	0.2	23.6	4.2	C
	Subtotal	110	113	102.3%	0.2	23.6	4.2	C
EB	Left Turn	170	168	98.8%	0.2	0.5	0.4	A
	Through							
	Right Turn							
	Subtotal	170	168	98.8%	0.2	0.5	0.4	A
WB	Left Turn							
	Through							
	Right Turn							
	Subtotal							
Total		280	280	100.1%	0.0	9.8	2.0	A

Intersection Main Street/Maple Street

Unsignalized

Direction	Movement	Volume (veh/hr)			GEH	Total Delay (sec/veh)		
		Demand	Served	% Served		Average	Std. Dev.	LOS
NB	Left Turn							
	Through	470	409	87.0%	2.9	31.7	2.2	D
	Right Turn							
	Subtotal	470	409	87.0%	2.9	31.7	2.2	D
SB	Left Turn							
	Through	500	371	74.2%	6.2	22.3	4.3	C
	Right Turn							
	Subtotal	500	371	74.2%	6.2	22.3	4.3	C
EB	Left Turn							
	Through							
	Right Turn							
	Subtotal							
WB	Left Turn							
	Through							
	Right Turn	20	18	88.0%	0.6	22.7	8.3	C
	Subtotal	20	18	88.0%	0.6	22.7	8.3	C
Total		990	798	80.6%	6.4	27.2	2.4	D

Intersection Main Street/Beech Street

Unsignalized

Direction	Movement	Volume (veh/hr)			GEH	Total Delay (sec/veh)		
		Demand	Served	% Served		Average	Std. Dev.	LOS
NB	Left Turn	80	82	103.0%	0.3	45.5	63.9	E
	Through	240	236	98.3%	0.3	41.3	61.2	E
	Right Turn							
	Subtotal	320	318	99.4%	0.1	42.4	61.8	E
SB	Left Turn							
	Through	360	264	73.4%	5.4	1.5	1.0	A
	Right Turn	10	9	91.0%	0.3	1.5	3.1	A
	Subtotal	370	273	73.8%	5.4	1.5	1.1	A
EB	Left Turn	60	56	93.5%	0.5	14.1	5.6	B
	Through							
	Right Turn	20	19	93.0%	0.3	7.0	3.7	A
	Subtotal	80	75	93.4%	0.6	12.3	5.0	B
WB	Left Turn							
	Through							
	Right Turn							
	Subtotal							
Total		770	666	86.5%	3.9	22.6	30.8	C

SimTraffic Post-Processor
Average Results from 20 Runs
Volume and Delay by Movement

Caltrain Electrification
2020 Plus Project Conditions
PM Peak Hour

Intersection Main Street/Middlefield Road

Signalized

Direction	Movement	Volume (veh/hr)			GEH	Total Delay (sec/veh)		
		Demand	Served	% Served		Average	Std. Dev.	LOS
NB	Left Turn	60	51	84.3%	1.3	143.9	15.2	F
	Through	400	347	86.7%	2.8	77.8	2.4	E
	Right Turn	30	26	86.0%	0.8	69.2	14.1	E
	Subtotal	490	423	86.4%	3.1	85.2	2.4	F
SB	Left Turn	100	49	49.3%	5.9	2345.2	578.5	F
	Through	360	244	67.8%	6.7	876.7	346.6	F
	Right Turn	60	42	69.5%	2.6	660.7	374.8	F
	Subtotal	520	335	64.4%	9.0	1068.8	391.2	F
EB	Left Turn	90	80	88.4%	1.1	369.6	150.9	F
	Through	390	340	87.3%	2.6	400.8	155.3	F
	Right Turn	90	78	86.9%	1.3	458.5	155.9	F
	Subtotal	570	498	87.4%	3.1	404.7	154.9	F
WB	Left Turn	50	42	83.6%	1.2	8.8	4.0	A
	Through	580	531	91.5%	2.1	7.7	0.6	A
	Right Turn	100	87	87.2%	1.3	0.5	0.3	A
	Subtotal	730	660	90.4%	2.7	6.8	0.6	A
Total		2310	1916	82.9%	8.6	309.6	53.0	F

Intersection Fair Oaks Lane/Middlefield Road

Unsignalized

Direction	Movement	Volume (veh/hr)			GEH	Total Delay (sec/veh)		
		Demand	Served	% Served		Average	Std. Dev.	LOS
NB	Left Turn	30	30	98.3%	0.1	128.7	47.7	F
	Through	20	22	110.0%	0.4	127.7	39.7	F
	Right Turn	130	122	93.9%	0.7	57.3	28.6	F
	Subtotal	180	174	96.4%	0.5	77.8	34.7	F
SB	Left Turn	10	11	108.0%	0.2	73.3	33.8	F
	Through	20	21	102.5%	0.1	71.8	37.4	F
	Right Turn	10	10	102.0%	0.1	38.1	21.6	E
	Subtotal	40	42	103.8%	0.2	64.5	29.3	F
EB	Left Turn	20	20	101.5%	0.1	9.6	2.4	A
	Through	670	675	100.8%	0.2	3.8	0.8	A
	Right Turn	40	42	105.0%	0.3	2.8	0.9	A
	Subtotal	730	738	101.0%	0.3	3.9	0.8	A
WB	Left Turn	190	170	89.4%	1.5	14.5	2.0	B
	Through	910	812	89.2%	3.3	5.9	0.5	A
	Right Turn	20	17	82.5%	0.8	5.4	1.0	A
	Subtotal	1120	998	89.1%	3.7	7.3	0.6	A
Total		2070	1951	94.2%	2.7	13.5	3.4	B

Intersection Watkins Avenue/Middlefield Road

Unsignalized

Direction	Movement	Volume (veh/hr)			GEH	Total Delay (sec/veh)		
		Demand	Served	% Served		Average	Std. Dev.	LOS
NB	Left Turn	60	64	107.2%	0.5	118.5	81.3	F
	Through							
	Right Turn	60	58	96.3%	0.3	61.4	65.1	F
	Subtotal	120	122	101.8%	0.2	91.5	75.2	F
SB	Left Turn							
	Through							
	Right Turn							
	Subtotal							
EB	Left Turn							
	Through	670	667	99.6%	0.1	5.4	0.7	A
	Right Turn	140	139	98.9%	0.1	4.3	0.5	A
	Subtotal	810	806	99.5%	0.1	5.2	0.6	A
WB	Left Turn	80	66	82.8%	1.6	17.0	3.6	C
	Through	1060	949	89.5%	3.5	7.2	0.3	A
	Right Turn							
	Subtotal	1140	1015	89.0%	3.8	7.8	0.3	A
Total		2070	1943	93.9%	2.8	12.1	5.1	B

SimTraffic Post-Processor
Average Results from 20 Runs
Volume and Delay by Movement

Caltrain Electrification
2020 Plus Project Conditions
PM Peak Hour

Intersection

Linden Avenue-Glenwood Avenue/Middlefield Road

Unsignalized

Direction	Movement	Volume (veh/hr)			GEH	Total Delay (sec/veh)		
		Demand	Served	% Served		Average	Std. Dev.	LOS
NB	Left Turn	150	37	24.7%	11.7	2664.8	574.0	F
	Through	20	5	23.0%	4.4	2692.8	667.8	F
	Right Turn	110	29	26.2%	9.7	2346.6	388.1	F
	Subtotal	280	71	25.2%	15.8	2528.8	477.9	F
SB	Left Turn	30	14	46.7%	3.4	1276.1	382.5	F
	Through	10	5	53.0%	1.7	1226.2	337.3	F
	Right Turn	100	57	56.8%	4.9	1145.4	278.2	F
	Subtotal	140	76	54.4%	6.1	1174.9	288.9	F
EB	Left Turn	50	48	96.2%	0.3	23.6	6.2	C
	Through	550	560	101.8%	0.4	8.0	0.6	A
	Right Turn	130	125	96.2%	0.4	6.4	0.5	A
	Subtotal	730	733	100.4%	0.1	8.7	0.7	A
WB	Left Turn	190	187	98.2%	0.2	13.4	1.6	B
	Through	890	896	100.7%	0.2	4.9	1.2	A
	Right Turn	90	96	106.3%	0.6	3.7	1.0	A
	Subtotal	1170	1178	100.7%	0.2	6.2	1.1	A
Total		2320	2058	88.7%	5.6	132.6	22.5	F

SimTraffic Post-Processor
Average Results from 20 Runs
Volume and Delay by Movement

Caltrain Electrification
2020 Plus Project Conditions
PM Peak Hour

Intersection California Street/Rengstorff Avenue

Signalized

Direction	Movement	Volume (veh/hr)			GEH	Total Delay (sec/veh)		
		Demand	Served	% Served		Average	Std. Dev.	LOS
NB	Left Turn	80	77	95.8%	0.4	58.3	3.8	E
	Through	350	338	96.5%	0.7	35.6	1.5	D
	Right Turn	100	107	107.3%	0.7	30.4	4.8	C
	Subtotal	530	522	98.4%	0.4	37.9	1.7	D
SB	Left Turn	160	151	94.3%	0.7	67.2	12.3	E
	Through	550	544	98.9%	0.3	32.8	1.0	C
	Right Turn	70	69	98.3%	0.1	29.3	3.2	C
	Subtotal	780	764	97.9%	0.6	39.2	2.5	D
EB	Left Turn	70	74	105.6%	0.5	55.2	7.0	E
	Through	440	448	101.7%	0.4	36.8	1.5	D
	Right Turn	170	164	96.3%	0.5	35.0	1.7	C
	Subtotal	680	685	100.8%	0.2	38.4	1.4	D
WB	Left Turn	280	284	101.4%	0.2	84.5	12.0	F
	Through	560	556	99.4%	0.2	29.9	2.4	C
	Right Turn	190	188	98.8%	0.2	25.0	1.9	C
	Subtotal	1030	1028	99.8%	0.1	44.1	4.5	D
Total		3020	2998	99.3%	0.4	40.5	1.5	D

2020 Project Mitigated



Intersection

El Camino Real/Millbrae Avenue

Signalized

Direction	Movement	Volume (veh/hr)			GEH	Total Delay (sec/veh)		
		Demand	Served	% Served		Average	Std. Dev.	LOS
NB	Left Turn	40	39	96.5%	0.2	90.5	9.6	F
	Through	400	397	99.3%	0.1	43.5	2.2	D
	Right Turn	570	566	99.2%	0.2	5.7	0.4	A
	Subtotal	1010	1001	99.1%	0.3	24.0	1.1	C
SB	Left Turn	690	669	96.9%	0.8	106.1	22.2	F
	Through	800	794	99.3%	0.2	37.9	3.9	D
	Right Turn	40	39	98.0%	0.1	37.9	6.8	D
	Subtotal	1530	1502	98.2%	0.7	68.4	11.5	E
EB	Left Turn	60	60	99.3%	0.1	100.8	13.5	F
	Through	780	779	99.8%	0.1	73.9	10.5	E
	Right Turn	30	30	100.3%	0.0	74.7	10.6	E
	Subtotal	870	868	99.8%	0.1	75.8	10.1	E
WB	Left Turn	450	442	98.1%	0.4	82.0	8.2	F
	Through	210	212	101.0%	0.1	39.3	2.6	D
	Right Turn	530	522	98.5%	0.4	12.1	0.6	B
	Subtotal	1190	1176	98.8%	0.4	43.3	3.1	D
Total		4600	4547	98.9%	0.8	53.6	3.7	D

Intersection

Rollins Road/Millbrae Avenue

Signalized

Direction	Movement	Volume (veh/hr)			GEH	Total Delay (sec/veh)		
		Demand	Served	% Served		Average	Std. Dev.	LOS
NB	Left Turn	120	119	99.4%	0.1	36.3	3.0	D
	Through	140	144	102.5%	0.3	51.1	13.4	D
	Right Turn	250	249	99.7%	0.1	21.9	9.7	C
	Subtotal	510	512	100.4%	0.1	33.6	9.0	C
SB	Left Turn	210	219	104.1%	0.6	31.0	1.1	C
	Through	20	20	101.5%	0.1	27.4	4.5	C
	Right Turn	80	76	94.8%	0.5	6.8	0.5	A
	Subtotal	310	315	101.5%	0.3	24.9	0.9	C
EB	Left Turn	380	370	97.2%	0.5	79.4	24.7	E
	Through	1340	1335	99.6%	0.1	36.8	2.9	D
	Right Turn	320	315	98.4%	0.3	21.7	2.6	C
	Subtotal	2040	2020	99.0%	0.5	42.4	5.6	D
WB	Left Turn	440	438	99.5%	0.1	51.3	5.4	D
	Through	990	978	98.7%	0.4	46.7	5.5	D
	Right Turn	480	489	101.9%	0.4	14.4	4.2	B
	Subtotal	1910	1905	99.7%	0.1	39.5	4.6	D
Total		4770	4751	99.6%	0.3	39.1	3.5	D

Intersection

California Drive/Oak Grove Avenue

Signalized

Direction	Movement	Volume (veh/hr)			GEH	Total Delay (sec/veh)		
		Demand	Served	% Served		Average	Std. Dev.	LOS
NB	Left Turn	30	2	5.3%	7.1	70.1	39.6	E
	Through	480	26	5.3%	28.6	26.5	7.7	C
	Right Turn	230	11	4.7%	20.0	2.1	0.2	A
	Subtotal	740	38	5.1%	35.6	21.3	5.6	C
SB	Left Turn	110	112	101.9%	0.2	80.0	13.0	E
	Through	630	642	101.9%	0.5	39.4	4.0	D
	Right Turn	50	47	93.0%	0.5	12.3	3.0	B
	Subtotal	790	801	101.3%	0.4	43.6	5.2	D
EB	Left Turn	80	82	102.8%	0.2	53.3	4.4	D
	Through	310	311	100.4%	0.1	59.5	7.0	E
	Right Turn	30	30	100.3%	0.0	52.5	12.0	D
	Subtotal	420	424	100.8%	0.2	57.8	6.5	E
WB	Left Turn	160	139	86.6%	1.8	30.2	2.0	C
	Through	100	89	89.1%	1.1	33.1	3.5	C
	Right Turn	90	78	86.7%	1.3	15.5	4.2	B
	Subtotal	350	306	87.3%	2.5	27.3	2.4	C
Total		2300	1567	68.1%	16.7	43.7	3.8	D

Intersection

Carolan Avenue/Oak Grove Avenue

Signalized

Direction	Movement	Volume (veh/hr)			GEH	Total Delay (sec/veh)		
		Demand	Served	% Served		Average	Std. Dev.	LOS
NB	Left Turn	50	13	25.6%	6.6	1865.3	202.7	F
	Through	120	35	29.2%	9.7	1744.5	144.9	F
	Right Turn	40	10	25.5%	5.9	1777.2	231.0	F
	Subtotal	210	58	27.6%	13.1	1774.8	139.7	F
SB	Left Turn	10	8	82.0%	0.6	297.6	69.6	F
	Through	120	110	91.5%	1.0	257.4	54.7	F
	Right Turn	170	161	94.5%	0.7	295.4	85.7	F
	Subtotal	300	279	92.9%	1.3	280.3	71.5	F
EB	Left Turn	380	252	66.2%	7.2	3.7	0.5	A
	Through	160	115	71.8%	3.8	4.2	0.8	A
	Right Turn	110	75	68.3%	3.6	0.6	0.3	A
	Subtotal	650	442	67.9%	8.9	3.3	0.4	A
WB	Left Turn	20	21	104.5%	0.2	79.6	38.0	E
	Through	130	128	98.1%	0.2	75.8	16.3	E
	Right Turn	20	21	103.0%	0.1	56.6	20.5	E
	Subtotal	170	169	99.4%	0.1	74.1	19.4	E
Total		1330	947	71.2%	11.3	205.1	18.1	F

Intersection

California Drive/North Lane

Unsignalized

Direction	Movement	Volume (veh/hr)			GEH	Total Delay (sec/veh)		
		Demand	Served	% Served		Average	Std. Dev.	LOS
NB	Left Turn							
	Through	720	727	101.0%	0.3	1.0	0.1	A
	Right Turn	190	195	102.4%	0.3	1.6	0.5	A
	Subtotal	910	922	101.3%	0.4	1.1	0.2	A
SB	Left Turn	120	7	5.9%	14.2	16.5	10.7	C
	Through	660	31	4.7%	33.8	0.7	0.2	A
	Right Turn							
	Subtotal	780	38	4.9%	36.7	3.6	2.4	A
EB	Left Turn							
	Through							
	Right Turn							
	Subtotal							
WB	Left Turn	60	38	63.2%	3.2	12.3	2.3	B
	Through							
	Right Turn	110	72	65.6%	4.0	4.6	0.4	A
	Subtotal	170	110	64.8%	5.1	7.2	0.7	A
Total		1860	1070	57.5%	20.6	1.9	0.2	A

Intersection

Carolan Avenue/North Lane

Unsignalized

Direction	Movement	Volume (veh/hr)			GEH	Total Delay (sec/veh)		
		Demand	Served	% Served		Average	Std. Dev.	LOS
NB	Left Turn	80	75	94.0%	0.5	10.7	1.7	B
	Through	150	145	96.5%	0.4	9.8	1.7	A
	Right Turn	20	20	99.5%	0.0	5.3	0.9	A
	Subtotal	250	240	96.0%	0.6	9.7	1.2	A
SB	Left Turn	10	3	32.0%	2.6	9.5	4.1	A
	Through	130	45	34.5%	9.1	12.3	1.5	B
	Right Turn	90	33	36.4%	7.3	7.9	1.6	A
	Subtotal	230	81	35.2%	12.0	10.4	1.3	B
EB	Left Turn	200	131	65.4%	5.4	0.6	0.1	A
	Through	20	16	79.5%	1.0	0.8	0.5	A
	Right Turn	90	60	66.7%	3.5	0.3	0.1	A
	Subtotal	310	207	66.7%	6.4	0.5	0.1	A
WB	Left Turn							
	Through							
	Right Turn							
	Subtotal							
Total		790	528	66.8%	10.2	6.2	0.7	A

Intersection El Camino Real/31st Street

Signalized

Direction	Movement	Volume (veh/hr)			GEH	Total Delay (sec/veh)		
		Demand	Served	% Served		Average	Std. Dev.	LOS
NB	Left Turn	70	71	101.3%	0.1	72.2	15.5	E
	Through	1390	1398	100.6%	0.2	19.2	1.7	B
	Right Turn	120	126	104.9%	0.5	2.6	0.4	A
	Subtotal	1580	1595	100.9%	0.4	20.2	1.8	C
SB	Left Turn	60	56	93.0%	0.6	50.3	10.7	D
	Through	1300	1320	101.6%	0.6	21.4	2.0	C
	Right Turn	120	120	99.7%	0.0	15.7	2.5	B
	Subtotal	1480	1496	101.1%	0.4	22.1	1.9	C
EB	Left Turn	120	117	97.8%	0.2	39.2	3.6	D
	Through	50	50	99.8%	0.0	52.2	8.1	D
	Right Turn	170	170	99.9%	0.0	6.0	0.8	A
	Subtotal	340	337	99.2%	0.2	24.4	2.3	C
WB	Left Turn	20	19	97.0%	0.1	21.2	4.7	C
	Through	60	60	100.5%	0.0	18.2	1.4	B
	Right Turn	60	59	98.8%	0.1	7.5	1.0	A
	Subtotal	140	139	99.3%	0.1	14.1	1.5	B
Total		3540	3567	100.8%	0.4	21.2	1.6	C

Intersection El Camino Real/Hillsdale Blvd

Signalized

Direction	Movement	Volume (veh/hr)			GEH	Total Delay (sec/veh)		
		Demand	Served	% Served		Average	Std. Dev.	LOS
NB	Left Turn							
	Through							
	Right Turn							
	Subtotal							
SB	Left Turn	350	356	101.7%	0.3	35.2	2.5	D
	Through							
	Right Turn	70	71	101.9%	0.2	5.5	1.5	A
	Subtotal	420	427	101.8%	0.4	30.3	2.0	C
EB	Left Turn							
	Through	460	467	101.5%	0.3	64.3	12.1	E
	Right Turn	80	76	94.9%	0.5	26.9	9.8	C
	Subtotal	540	543	100.5%	0.1	59.1	11.9	E
WB	Left Turn	420	409	97.4%	0.5	10.8	0.7	B
	Through	720	699	97.1%	0.8	9.2	1.0	A
	Right Turn							
	Subtotal	1140	1108	97.2%	0.9	9.8	0.6	A
Total		2970	2945	99.1%	0.5	55.7	3.3	E

SimTraffic Post-Processor
Average Results from 20 Runs
Volume and Delay by Movement

Caltrain Electrification
2020 Plus Project Conditions with Mitigation
AM Peak Hour

Intersection

Curtiss Street/Hillsdale Blvd

Signalized

Direction	Movement	Volume (veh/hr)			GEH	Total Delay (sec/veh)		
		Demand	Served	% Served		Average	Std. Dev.	LOS
NB	Left Turn	140	145	103.7%	0.4	25.9	2.5	C
	Through	10	7	67.0%	1.1	25.2	7.8	C
	Right Turn	130	128	98.4%	0.2	12.7	1.2	B
	Subtotal	280	280	99.9%	0.0	19.8	1.6	B
SB	Left Turn	40	37	91.8%	0.5	22.0	2.2	C
	Through	10	9	94.0%	0.2	21.5	4.7	C
	Right Turn	40	43	107.5%	0.5	14.7	1.6	B
	Subtotal	90	89	99.0%	0.1	18.5	1.4	B
EB	Left Turn	10	9	94.0%	0.2	33.6	10.3	C
	Through	1150	1166	101.4%	0.5	14.4	1.2	B
	Right Turn	100	107	106.9%	0.7	14.2	1.6	B
	Subtotal	1260	1283	101.8%	0.6	14.5	1.2	B
WB	Left Turn	40	39	98.3%	0.1	47.1	8.7	D
	Through	1200	1177	98.1%	0.7	24.4	8.7	C
	Right Turn	30	33	109.3%	0.5	20.2	13.4	C
	Subtotal	1270	1249	98.3%	0.6	25.0	8.8	C
Total		2900	2900	100.0%	0.0	19.7	3.8	B

Intersection

El Camino Real/Atherton Avenue-Fair Oaks Lane

Signalized

Direction	Movement	Volume (veh/hr)			GEH	Total Delay (sec/veh)		
		Demand	Served	% Served		Average	Std. Dev.	LOS
NB	Left Turn	80	14	16.9%	9.7	63.2	20.0	E
	Through	790	132	16.7%	30.7	18.8	3.9	B
	Right Turn	30	5	17.7%	5.9	16.1	8.7	B
	Subtotal	900	151	16.7%	32.7	22.6	4.3	C
SB	Left Turn	70	11	15.3%	9.3	42.1	11.0	D
	Through	1720	268	15.6%	46.0	35.8	15.6	D
	Right Turn	180	28	15.4%	14.9	41.9	21.4	D
	Subtotal	1970	307	15.6%	49.3	36.5	15.9	D
EB	Left Turn	120	19	16.2%	12.0	35.0	8.3	C
	Through	80	13	16.1%	9.8	32.4	12.2	C
	Right Turn	150	26	17.1%	13.3	19.0	8.6	B
	Subtotal	350	58	16.5%	20.5	27.3	9.2	C
WB	Left Turn	80	14	17.0%	9.7	37.2	6.8	D
	Through	130	24	18.1%	12.2	32.5	5.6	C
	Right Turn	70	12	16.4%	9.2	12.3	5.4	B
	Subtotal	280	49	17.4%	18.1	29.0	5.2	C
Total		3500	564	16.1%	65.1	31.4	9.7	C

Intersection

El Camino Real/Watkins Avenue

Signalized

Direction	Movement	Volume (veh/hr)			GEH	Total Delay (sec/veh)		
		Demand	Served	% Served		Average	Std. Dev.	LOS
NB	Left Turn							
	Through	830	141	17.0%	31.3	3.0	0.8	A
	Right Turn	70	12	17.3%	9.0	3.2	0.9	A
	Subtotal	900	153	17.0%	32.5	3.0	0.7	A
SB	Left Turn	70	10	13.6%	9.6	12.7	3.1	B
	Through	1880	302	16.1%	47.8	8.0	1.2	A
	Right Turn							
	Subtotal	1950	311	16.0%	48.7	8.1	1.2	A
EB	Left Turn							
	Through							
	Right Turn							
	Subtotal							
WB	Left Turn	70	11	15.7%	9.3	19.6	3.6	B
	Through							
	Right Turn	70	14	20.0%	8.6	9.6	3.9	A
	Subtotal	140	25	17.9%	12.7	14.0	3.7	B
Total		2990	490	16.4%	59.9	6.8	0.9	A

Intersection El Camino Real/Glenwood

Signalized

Direction	Movement	Volume (veh/hr)			GEH	Total Delay (sec/veh)		
		Demand	Served	% Served		Average	Std. Dev.	LOS
NB	Left Turn	70	69	99.0%	0.1	79.3	10.1	E
	Through	1050	1028	97.9%	0.7	24.1	1.1	C
	Right Turn	40	37	91.5%	0.5	18.8	3.3	B
	Subtotal	1160	1134	97.8%	0.8	27.3	1.5	C
SB	Left Turn	70	61	87.4%	1.1	69.9	13.0	E
	Through	1380	1387	100.5%	0.2	32.4	8.8	C
	Right Turn	470	478	101.7%	0.4	10.4	1.2	B
	Subtotal	1920	1926	100.3%	0.1	28.1	7.0	C
EB	Left Turn	260	264	101.6%	0.3	100.7	27.1	F
	Through	150	153	101.7%	0.2	104.6	23.6	F
	Right Turn	110	110	100.2%	0.0	62.5	21.3	E
	Subtotal	520	527	101.3%	0.3	93.8	24.5	F
WB	Left Turn	80	77	96.3%	0.3	111.6	48.2	F
	Through	190	188	99.2%	0.1	118.7	47.3	F
	Right Turn	20	19	92.5%	0.3	102.9	51.1	F
	Subtotal	290	284	97.9%	0.4	115.7	47.7	F
Total		3890	3871	99.5%	0.3	43.4	6.4	D

Intersection El Camino Real/Oak Grove

Signalized

Direction	Movement	Volume (veh/hr)			GEH	Total Delay (sec/veh)		
		Demand	Served	% Served		Average	Std. Dev.	LOS
NB	Left Turn	90	82	91.2%	0.9	103.9	37.1	F
	Through	1050	1014	96.6%	1.1	14.2	1.0	B
	Right Turn	80	79	99.3%	0.1	7.8	1.8	A
	Subtotal	1220	1175	96.3%	1.3	20.1	3.5	C
SB	Left Turn	110	112	101.7%	0.2	66.5	9.8	E
	Through	1390	1367	98.4%	0.6	39.0	9.6	D
	Right Turn	70	65	93.1%	0.6	31.9	10.4	C
	Subtotal	1570	1544	98.4%	0.7	40.7	9.5	D
EB	Left Turn	70	71	101.6%	0.1	82.8	18.5	F
	Through	180	180	100.1%	0.0	50.4	5.6	D
	Right Turn	50	51	102.4%	0.2	33.1	5.0	C
	Subtotal	300	302	100.8%	0.1	55.3	8.0	E
WB	Left Turn	110	109	98.9%	0.1	141.5	35.9	F
	Through	200	192	95.8%	0.6	75.2	22.8	E
	Right Turn	40	41	103.5%	0.2	29.5	16.0	C
	Subtotal	350	342	97.7%	0.4	90.7	25.7	F
Total		3440	3364	97.8%	1.3	40.0	4.7	D

Intersection El Camino Real/Santa Cruz Ave

Signalized

Direction	Movement	Volume (veh/hr)			GEH	Total Delay (sec/veh)		
		Demand	Served	% Served		Average	Std. Dev.	LOS
NB	Left Turn							
	Through	1090	1070	98.2%	0.6	3.6	0.4	A
	Right Turn	140	136	97.3%	0.3	5.1	4.7	A
	Subtotal	1230	1206	98.1%	0.7	3.8	0.9	A
SB	Left Turn							
	Through	1460	1428	97.8%	0.8	20.3	2.3	C
	Right Turn	90	90	99.4%	0.1	12.7	1.9	B
	Subtotal	1550	1518	97.9%	0.8	19.9	2.3	B
EB	Left Turn	100	100	99.5%	0.1	42.0	3.7	D
	Through	80	80	99.9%	0.0	43.8	11.1	D
	Right Turn	170	182	106.9%	0.9	26.0	3.9	C
	Subtotal	350	361	103.2%	0.6	34.3	2.8	C
WB	Left Turn	70	59	84.9%	1.3	39.9	2.4	D
	Through	70	66	94.9%	0.4	42.7	4.9	D
	Right Turn	30	24	81.3%	1.1	28.2	6.2	C
	Subtotal	170	150	88.4%	1.6	39.1	2.9	D
Total		3300	3235	98.0%	1.1	16.4	1.1	B

Intersection Merrill St/Santa Cruz Ave

Unsignalized

Direction	Movement	Volume (veh/hr)			GEH	Total Delay (sec/veh)		
		Demand	Served	% Served		Average	Std. Dev.	LOS
NB	Left Turn	70	53	75.7%	2.2	11.5	16.7	B
	Through	20	20	98.0%	0.1	12.7	16.4	B
	Right Turn	10	9	85.0%	0.5	4.3	1.7	A
	Subtotal	100	81	81.1%	2.0	10.8	14.0	B
SB	Left Turn	20	18	89.5%	0.5	8.1	1.8	A
	Through	30	30	99.0%	0.1	9.9	1.6	A
	Right Turn	80	72	90.0%	0.9	6.1	0.6	A
	Subtotal	130	120	92.0%	0.9	7.3	0.8	A
EB	Left Turn	80	77	95.8%	0.4	12.6	12.4	B
	Through	20	21	106.0%	0.3	11.7	13.5	B
	Right Turn	120	119	99.4%	0.1	7.9	4.0	A
	Subtotal	220	217	98.7%	0.2	10.0	8.1	A
WB	Left Turn	10	10	100.0%	0.0	3.5	0.7	A
	Through	20	22	111.5%	0.5	4.1	0.7	A
	Right Turn	10	10	95.0%	0.2	8.6	13.9	A
	Subtotal	40	42	104.5%	0.3	5.1	3.5	A
Total		490	460	93.8%	1.4	9.2	7.3	A

Intersection Ravenswood Ave/Laurel St

Signalized

Direction	Movement	Volume (veh/hr)			GEH	Total Delay (sec/veh)		
		Demand	Served	% Served		Average	Std. Dev.	LOS
NB	Left Turn	170	152	89.2%	1.5	189.1	96.4	F
	Through	70	64	90.7%	0.8	152.7	84.3	F
	Right Turn	30	28	92.0%	0.4	130.8	67.2	F
	Subtotal	270	243	89.9%	1.7	173.3	88.6	F
SB	Left Turn	170	149	87.8%	1.6	223.4	34.3	F
	Through	170	145	85.3%	2.0	221.2	35.2	F
	Right Turn	80	65	81.6%	1.7	222.3	38.0	F
	Subtotal	420	360	85.6%	3.1	222.4	34.5	F
EB	Left Turn	40	38	95.3%	0.3	81.9	11.4	F
	Through	770	691	89.7%	2.9	41.4	3.6	D
	Right Turn	80	73	90.9%	0.8	36.2	5.8	D
	Subtotal	890	801	90.0%	3.1	42.8	3.4	D
WB	Left Turn	20	16	78.5%	1.0	253.2	75.3	F
	Through	570	485	85.0%	3.7	230.1	72.8	F
	Right Turn	20	17	86.5%	0.6	220.2	96.5	F
	Subtotal	610	518	84.9%	3.9	230.6	72.9	F
Total		2190	1921	87.7%	5.9	143.0	29.0	F

Intersection Fair Oaks Lane/Middlefield Road

Unsignalized

Direction	Movement	Volume (veh/hr)			GEH	Total Delay (sec/veh)		
		Demand	Served	% Served		Average	Std. Dev.	LOS
NB	Left Turn	20	19	95.0%	0.2	238.0	120.3	F
	Through	10	7	71.0%	1.0	158.0	100.8	F
	Right Turn	200	200	99.9%	0.0	134.5	111.9	F
	Subtotal	230	226	98.2%	0.3	143.5	111.5	F
SB	Left Turn	20	14	68.5%	1.5	660.8	209.8	F
	Through	70	57	81.9%	1.6	621.8	173.3	F
	Right Turn	50	42	83.6%	1.2	609.1	169.9	F
	Subtotal	140	113	80.6%	2.4	622.6	173.8	F
EB	Left Turn	10	7	70.0%	1.0	6.4	0.6	A
	Through	700	698	99.7%	0.1	4.8	0.3	A
	Right Turn	110	107	96.9%	0.3	3.6	0.4	A
	Subtotal	820	811	99.0%	0.3	4.6	0.3	A
WB	Left Turn	220	217	98.7%	0.2	23.4	2.4	C
	Through	440	460	104.6%	1.0	6.7	1.0	A
	Right Turn	20	22	109.0%	0.4	7.6	2.5	A
	Subtotal	680	699	102.8%	0.7	11.9	1.4	B
Total		1870	1849	98.9%	0.5	61.8	19.9	F

Intersection Watkins Avenue/Middlefield Road

Unsignalized

Direction	Movement	Volume (veh/hr)			GEH	Total Delay (sec/veh)		
		Demand	Served	% Served		Average	Std. Dev.	LOS
NB	Left Turn	70	71	101.1%	0.1	71.3	23.4	F
	Through							
	Right Turn	80	83	103.8%	0.3	32.8	16.8	D
	Subtotal	150	154	102.5%	0.3	50.4	19.3	F
SB	Left Turn							
	Through							
	Right Turn							
	Subtotal							
EB	Left Turn							
	Through	820	819	99.8%	0.0	4.9	0.3	A
	Right Turn	100	104	104.1%	0.4	4.0	0.4	A
	Subtotal	920	923	100.3%	0.1	4.8	0.2	A
WB	Left Turn	60	59	98.2%	0.1	17.6	2.2	C
	Through	610	624	102.3%	0.6	6.0	0.3	A
	Right Turn							
	Subtotal	670	683	102.0%	0.5	7.0	0.4	A
Total		1740	1760	101.1%	0.5	9.6	1.8	A

Intersection

Linden Avenue-Glenwood Avenue/Middlefield Road

Signalized

Direction	Movement	Volume (veh/hr)			GEH	Total Delay (sec/veh)		
		Demand	Served	% Served		Average	Std. Dev.	LOS
NB	Left Turn	70	69	98.6%	0.1	20.3	2.6	C
	Through	10	10	101.0%	0.0	19.1	5.2	B
	Right Turn	100	102	101.5%	0.1	10.9	1.7	B
	Subtotal	180	181	100.3%	0.0	14.9	1.6	B
SB	Left Turn	30	28	93.3%	0.4	19.6	2.7	B
	Through	10	10	103.0%	0.1	17.9	3.4	B
	Right Turn	40	40	98.8%	0.1	8.0	2.5	A
	Subtotal	80	78	97.3%	0.2	13.5	2.5	B
EB	Left Turn	50	45	89.8%	0.7	28.9	6.3	C
	Through	680	692	101.8%	0.5	21.5	3.4	C
	Right Turn	170	165	97.2%	0.4	18.2	3.4	B
	Subtotal	900	902	100.3%	0.1	21.3	3.6	C
WB	Left Turn	90	93	103.0%	0.3	55.4	25.6	E
	Through	560	569	101.5%	0.4	11.0	6.1	B
	Right Turn	10	12	116.0%	0.5	8.4	8.0	A
	Subtotal	660	673	102.0%	0.5	17.2	9.5	B
Total		1820	1834	100.8%	0.3	18.8	5.1	B

Intersection

El Camino Real/Millbrae Avenue

Signalized

Direction	Movement	Volume (veh/hr)			GEH	Total Delay (sec/veh)		
		Demand	Served	% Served		Average	Std. Dev.	LOS
NB	Left Turn	40	39	97.8%	0.1	81.0	19.5	F
	Through	870	871	100.1%	0.0	50.5	1.7	D
	Right Turn	420	427	101.7%	0.3	3.5	0.2	A
	Subtotal	1330	1337	100.6%	0.2	36.4	1.9	D
SB	Left Turn	690	683	99.0%	0.3	70.9	6.7	E
	Through	1090	1098	100.7%	0.2	26.7	1.2	C
	Right Turn	70	70	100.4%	0.0	27.7	3.4	C
	Subtotal	1850	1852	100.1%	0.0	43.1	3.0	D
EB	Left Turn	140	134	96.0%	0.5	129.9	23.2	F
	Through	430	431	100.3%	0.1	72.5	9.3	E
	Right Turn	60	63	105.5%	0.4	65.7	10.3	E
	Subtotal	630	629	99.9%	0.0	84.2	12.6	F
WB	Left Turn	610	588	96.3%	0.9	78.0	8.6	E
	Through	790	794	100.5%	0.1	60.6	5.1	E
	Right Turn	750	740	98.7%	0.4	19.1	1.9	B
	Subtotal	2150	2122	98.7%	0.6	51.0	3.7	D
Total		5960	5940	99.7%	0.3	48.8	2.7	D

Intersection

Rollins Road/Millbrae Avenue

Signalized

Direction	Movement	Volume (veh/hr)			GEH	Total Delay (sec/veh)		
		Demand	Served	% Served		Average	Std. Dev.	LOS
NB	Left Turn	360	347	96.3%	0.7	54.8	4.5	D
	Through	90	90	100.0%	0.0	49.4	4.9	D
	Right Turn	450	450	99.9%	0.0	26.6	5.3	C
	Subtotal	900	886	98.4%	0.5	40.0	3.3	D
SB	Left Turn	390	395	101.2%	0.2	42.1	1.6	D
	Through	120	121	100.5%	0.1	38.9	3.2	D
	Right Turn	250	252	100.8%	0.1	25.1	2.8	C
	Subtotal	760	767	100.9%	0.3	36.0	1.9	D
EB	Left Turn	200	197	98.4%	0.2	61.5	11.1	E
	Through	1120	1137	101.6%	0.5	37.4	1.3	D
	Right Turn	220	217	98.8%	0.2	16.6	1.1	B
	Subtotal	1540	1552	100.7%	0.3	37.6	2.1	D
WB	Left Turn	360	367	101.9%	0.4	52.9	2.7	D
	Through	1540	1529	99.3%	0.3	48.4	6.8	D
	Right Turn	240	246	102.4%	0.4	3.8	0.2	A
	Subtotal	2140	2142	100.1%	0.0	44.1	5.1	D
Total		5340	5347	100.1%	0.1	40.4	2.2	D

Intersection

California Drive/Oak Grove

Signalized

Direction	Movement	Volume (veh/hr)			GEH	Total Delay (sec/veh)		
		Demand	Served	% Served		Average	Std. Dev.	LOS
NB	Left Turn	50	8	15.6%	7.8	66.1	20.1	E
	Through	580	93	16.1%	26.5	29.6	3.5	C
	Right Turn	250	42	16.6%	17.3	9.4	3.1	A
	Subtotal	880	143	16.2%	32.6	25.7	2.4	C
SB	Left Turn	60	6	9.8%	9.4	6793.2	1166.2	F
	Through	710	199	28.1%	24.0	122.4	36.7	F
	Right Turn	70	22	31.6%	7.1	34.0	12.4	C
	Subtotal	840	227	27.1%	26.5	291.5	76.2	F
EB	Left Turn	30	17	57.0%	2.7	148.9	16.8	F
	Through	250	161	64.6%	6.2	241.0	15.7	F
	Right Turn	40	22	56.0%	3.2	218.0	22.3	F
	Subtotal	320	201	62.8%	7.4	230.7	13.4	F
WB	Left Turn	200	124	61.8%	6.0	27.2	2.2	C
	Through	180	125	69.2%	4.5	27.7	2.8	C
	Right Turn	140	97	69.1%	4.0	13.3	3.7	B
	Subtotal	520	345	66.3%	8.4	23.5	1.8	C
Total		2560	916	35.8%	39.4	133.8	16.8	F

Intersection

Carolan Ave/Oak Grove

Signalized

Direction	Movement	Volume (veh/hr)			GEH	Total Delay (sec/veh)		
		Demand	Served	% Served		Average	Std. Dev.	LOS
NB	Left Turn	70	28	39.7%	6.0	1166.5	368.4	F
	Through	80	32	40.5%	6.3	1032.5	316.7	F
	Right Turn	70	26	37.1%	6.4	1042.4	404.4	F
	Subtotal	220	86	39.2%	10.8	1087.4	351.3	F
SB	Left Turn	30	28	93.7%	0.4	48.3	6.5	D
	Through	170	177	103.9%	0.5	47.0	4.4	D
	Right Turn	260	258	99.2%	0.1	37.7	11.9	D
	Subtotal	460	463	100.6%	0.1	42.0	7.8	D
EB	Left Turn	400	151	37.8%	15.0	31.5	2.8	C
	Through	90	43	48.1%	5.7	35.3	5.7	D
	Right Turn	70	31	43.7%	5.6	10.7	5.0	B
	Subtotal	560	225	40.2%	16.9	29.4	2.2	C
WB	Left Turn	50	11	22.2%	7.0	1476.8	150.0	F
	Through	190	44	23.2%	13.5	1505.7	83.0	F
	Right Turn	30	9	28.7%	4.9	1501.0	137.9	F
	Subtotal	270	64	23.6%	16.0	1501.4	73.0	F
Total		1510	838	55.5%	19.6	248.1	14.5	F

Intersection California Dr/North Lane

Unsignalized

Direction	Movement	Volume (veh/hr)			GEH	Total Delay (sec/veh)		
		Demand	Served	% Served		Average	Std. Dev.	LOS
NB	Left Turn							
	Through	680	690	101.4%	0.4	0.8	0.1	A
	Right Turn	60	63	105.2%	0.4	0.9	0.4	A
	Subtotal	740	753	101.7%	0.5	0.8	0.1	A
SB	Left Turn	140	18	13.0%	13.7	8.3	1.8	A
	Through	800	111	13.9%	32.3	1.5	0.7	A
	Right Turn							
	Subtotal	940	130	13.8%	35.0	2.5	0.6	A
EB	Left Turn							
	Through							
	Right Turn							
	Subtotal							
WB	Left Turn	50	38	75.0%	1.9	11.7	1.7	B
	Through							
	Right Turn	130	97	74.9%	3.1	5.2	0.6	A
	Subtotal	180	135	74.9%	3.6	7.0	0.8	A
Total		1860	1017	54.7%	22.2	1.8	0.1	A

Intersection Carolan Ave/North Lane

Unsignalized

Direction	Movement	Volume (veh/hr)			GEH	Total Delay (sec/veh)		
		Demand	Served	% Served		Average	Std. Dev.	LOS
NB	Left Turn	100	98	98.3%	0.2	14.7	2.8	B
	Through	130	135	103.7%	0.4	8.5	0.7	A
	Right Turn	10	10	102.0%	0.1	5.0	1.2	A
	Subtotal	240	243	101.4%	0.2	10.9	1.2	B
SB	Left Turn	10	4	40.0%	2.3	16.1	5.3	C
	Through	180	93	51.8%	7.4	13.9	2.8	B
	Right Turn	80	38	47.6%	5.5	15.6	5.8	C
	Subtotal	270	135	50.1%	9.5	14.4	3.3	B
EB	Left Turn	70	28	39.7%	6.0	0.7	0.4	A
	Through	10	7	71.0%	1.0	0.7	0.8	A
	Right Turn	120	53	43.8%	7.3	0.3	0.2	A
	Subtotal	200	87	43.7%	9.4	0.5	0.2	A
WB	Left Turn							
	Through							
	Right Turn							
	Subtotal							
Total		710	466	65.6%	10.1	10.0	1.8	A

Intersection **California/Broadway**

Unsignalized

Direction	Movement	Volume (veh/hr)			GEH	Total Delay (sec/veh)		
		Demand	Served	% Served		Average	Std. Dev.	LOS
NB	Left Turn	20	16	77.5%	1.1	641.7	219.8	F
	Through	40	32	80.5%	1.3	563.2	201.0	F
	Right Turn	70	57	81.1%	1.7	551.9	201.2	F
	Subtotal	130	105	80.4%	2.4	570.5	198.4	F
SB	Left Turn	30	17	57.0%	2.7	1769.1	722.8	F
	Through	60	39	64.5%	3.0	1655.0	704.3	F
	Right Turn	70	46	65.0%	3.2	1613.6	676.9	F
	Subtotal	160	101	63.3%	5.1	1651.0	669.5	F
EB	Left Turn	40	20	48.8%	3.8	122.4	17.1	F
	Through	530	305	57.6%	11.0	119.9	13.7	F
	Right Turn	90	56	62.0%	4.0	114.1	17.8	F
	Subtotal	660	381	57.7%	12.2	119.3	13.5	F
WB	Left Turn	160	91	56.8%	6.2	10.0	1.5	A
	Through	660	399	60.5%	11.3	4.0	0.5	A
	Right Turn	50	29	57.8%	3.4	0.2	0.1	A
	Subtotal	870	519	59.7%	13.3	4.8	0.6	A
Total		1820	1105	60.7%	18.7	242.5	57.3	F

Intersection **Arguello Street/Brewster Ave**

Signalized

Direction	Movement	Volume (veh/hr)			GEH	Total Delay (sec/veh)		
		Demand	Served	% Served		Average	Std. Dev.	LOS
NB	Left Turn	100	70	69.6%	3.3	95.2	14.0	F
	Through	250	171	68.3%	5.5	64.6	12.3	E
	Right Turn	70	47	66.7%	3.1	28.5	11.6	C
	Subtotal	420	287	68.4%	7.1	66.1	10.8	E
SB	Left Turn	30	22	74.7%	1.5	691.9	434.3	F
	Through	150	122	81.1%	2.4	716.8	434.9	F
	Right Turn	130	101	77.9%	2.7	726.9	484.3	F
	Subtotal	310	245	79.1%	3.9	715.9	446.8	F
EB	Left Turn	110	78	70.7%	3.3	12.3	3.3	B
	Through	180	148	82.0%	2.5	14.0	3.6	B
	Right Turn	60	51	85.2%	1.2	10.6	10.3	B
	Subtotal	350	277	79.0%	4.2	12.8	2.4	B
WB	Left Turn	50	47	93.0%	0.5	75.0	20.5	E
	Through	400	405	101.3%	0.3	64.6	5.5	E
	Right Turn	50	52	103.8%	0.3	46.6	10.8	D
	Subtotal	500	504	100.7%	0.2	63.8	6.0	E
Total		1580	1313	83.1%	7.0	164.6	60.9	F

Intersection **El Camino Real/Broadway**

Signalized

Direction	Movement	Volume (veh/hr)			GEH	Total Delay (sec/veh)		
		Demand	Served	% Served		Average	Std. Dev.	LOS
NB	Left Turn	210	188	89.4%	1.6	190.3	62.2	F
	Through	1250	1157	92.6%	2.7	89.6	6.9	F
	Right Turn	100	90	90.1%	1.0	126.1	28.1	F
	Subtotal	1560	1435	92.0%	3.2	105.5	5.3	F
SB	Left Turn	230	117	51.0%	8.6	448.7	48.0	F
	Through	1270	738	58.1%	16.8	33.4	1.8	C
	Right Turn	20	13	65.5%	1.7	20.3	4.7	C
	Subtotal	1520	868	57.1%	18.9	89.3	6.3	F
EB	Left Turn	20	10	50.5%	2.6	332.0	36.1	F
	Through	330	167	50.5%	10.4	328.0	28.3	F
	Right Turn	220	110	50.0%	8.6	261.6	21.3	F
	Subtotal	570	287	50.3%	13.7	302.7	24.8	F
WB	Left Turn	110	67	60.7%	4.6	44.9	5.6	D
	Through	390	240	61.6%	8.4	36.2	2.1	D
	Right Turn	250	155	62.0%	6.7	32.1	3.7	C
	Subtotal	750	462	61.6%	11.7	36.1	2.1	D
Total		4400	3051	69.4%	22.1	108.7	3.7	F

Intersection **Arguello St/Broadway**

Signalized

Direction	Movement	Volume (veh/hr)			GEH	Total Delay (sec/veh)		
		Demand	Served	% Served		Average	Std. Dev.	LOS
NB	Left Turn	50	40	80.0%	1.5	174.7	14.9	F
	Through	140	120	85.4%	1.8	151.1	16.6	F
	Right Turn	220	185	84.1%	2.5	143.1	13.3	F
	Subtotal	410	345	84.0%	3.4	149.6	13.8	F
SB	Left Turn	30	23	77.7%	1.3	283.1	127.6	F
	Through	160	137	85.6%	1.9	283.3	128.4	F
	Right Turn	70	57	81.6%	1.6	290.3	103.0	F
	Subtotal	260	217	83.6%	2.8	285.3	121.5	F
EB	Left Turn	180	108	59.8%	6.0	12.6	1.9	B
	Through	300	188	62.6%	7.2	5.4	0.8	A
	Right Turn	150	89	59.1%	5.6	1.0	0.3	A
	Subtotal	630	384	61.0%	10.9	6.4	1.0	A
WB	Left Turn	20	10	51.0%	2.5	138.3	28.0	F
	Through	750	422	56.3%	13.5	121.0	14.2	F
	Right Turn	100	55	54.9%	5.1	63.4	11.4	E
	Subtotal	870	487	56.0%	14.7	115.0	14.0	F
Total		2170	1433	66.1%	17.4	117.3	12.1	F

Intersection

El Camino Real/James

Signalized

Direction	Movement	Volume (veh/hr)			GEH	Total Delay (sec/veh)		
		Demand	Served	% Served		Average	Std. Dev.	LOS
NB	Left Turn	137	117	85.7%	1.7	162.2	36.4	F
	Through	1463	1284	87.7%	4.8	134.3	38.9	F
	Right Turn	42	37	86.9%	0.9	83.2	30.5	F
	Subtotal	1642	1438	87.5%	5.2	135.3	38.2	F
SB	Left Turn	126	61	48.1%	6.8	48.6	6.1	D
	Through	1474	799	54.2%	20.0	20.5	1.8	C
	Right Turn	84	51	60.4%	4.1	8.1	1.5	A
	Subtotal	1684	910	54.0%	21.5	21.6	1.9	C
EB	Left Turn	95	90	94.4%	0.6	63.1	11.5	E
	Through	200	193	96.4%	0.5	27.4	2.5	C
	Right Turn	105	105	100.4%	0.0	9.7	1.6	A
	Subtotal	400	388	97.0%	0.6	30.9	2.8	C
WB	Left Turn	126	75	59.1%	5.1	43.7	5.1	D
	Through	116	73	62.8%	4.4	33.0	5.1	C
	Right Turn	84	49	58.1%	4.3	43.6	10.2	D
	Subtotal	326	196	60.2%	8.0	39.7	5.2	D
Total		4052	2932	72.3%	19.0	79.6	18.6	E

Intersection

El Camino Real/Atherton Avenue-Fair Oaks Lane

Signalized

Direction	Movement	Volume (veh/hr)			GEH	Total Delay (sec/veh)		
		Demand	Served	% Served		Average	Std. Dev.	LOS
NB	Left Turn	230	34	14.7%	17.1	90.8	40.0	F
	Through	1820	307	16.9%	46.4	21.3	3.1	C
	Right Turn	80	11	13.6%	10.2	22.3	6.2	C
	Subtotal	2130	352	16.5%	50.5	28.1	6.2	C
SB	Left Turn	40	6	14.5%	7.1	50.9	13.2	D
	Through	1220	198	16.2%	38.4	23.4	2.0	C
	Right Turn	80	13	16.3%	9.8	24.9	4.2	C
	Subtotal	1340	217	16.2%	40.3	24.2	2.1	C
EB	Left Turn	130	20	15.2%	12.7	36.7	5.8	D
	Through	90	16	18.2%	10.1	37.1	7.0	D
	Right Turn	70	11	15.3%	9.3	19.6	5.1	B
	Subtotal	290	47	16.1%	18.7	32.8	5.1	C
WB	Left Turn	40	7	17.5%	6.8	40.6	11.1	D
	Through	110	18	16.5%	11.5	44.2	11.4	D
	Right Turn	70	12	17.6%	9.0	18.2	7.3	B
	Subtotal	220	38	17.0%	16.1	35.0	7.4	C
Total		3980	653	16.4%	69.1	27.6	3.9	C

Intersection

El Camino Real/Watkins Avenue

Signalized

Direction	Movement	Volume (veh/hr)			GEH	Total Delay (sec/veh)		
		Demand	Served	% Served		Average	Std. Dev.	LOS
NB	Left Turn							
	Through	2030	348	17.1%	48.8	5.1	0.9	A
	Right Turn	50	10	19.6%	7.4	6.0	2.8	A
	Subtotal	2080	358	17.2%	49.3	5.1	0.9	A
SB	Left Turn	30	4	12.0%	6.4	30.0	13.2	C
	Through	1300	208	16.0%	39.8	6.7	1.0	A
	Right Turn							
	Subtotal	1330	211	15.9%	40.3	7.1	1.1	A
EB	Left Turn							
	Through							
	Right Turn							
	Subtotal							
WB	Left Turn	50	7	14.4%	8.0	24.9	5.3	C
	Through							
	Right Turn	100	16	15.5%	11.1	15.1	3.8	B
	Subtotal	150	23	15.1%	13.7	18.3	3.5	B
Total		3560	592	16.6%	65.1	6.3	1.0	A

Intersection

Santa Clara Street/Cahill Street

Signalized

Direction	Movement	Volume (veh/hr)			GEH	Total Delay (sec/veh)		
		Demand	Served	% Served		Average	Std. Dev.	LOS
NB	Left Turn	130	134	102.7%	0.3	53.6	7.5	D
	Through	10	18	175.0%	2.0	35.0	15.3	C
	Right Turn	180	181	100.4%	0.1	34.0	4.3	C
	Subtotal	320	332	103.7%	0.6	42.0	5.4	D
SB	Left Turn	10	10	97.0%	0.1	65.6	18.0	E
	Through	10	12	116.0%	0.5	45.4	14.6	D
	Right Turn	10	9	93.0%	0.2	11.5	5.0	B
	Subtotal	30	31	102.0%	0.1	42.8	9.5	D
EB	Left Turn							
	Through	1110	1056	95.2%	1.6	69.1	8.1	E
	Right Turn	150	135	89.8%	1.3	71.5	7.0	E
	Subtotal	1260	1191	94.5%	2.0	69.3	7.9	E
WB	Left Turn	200	139	69.5%	4.7	82.6	11.1	F
	Through	780	572	73.3%	8.0	6.4	0.7	A
	Right Turn	10	8	81.0%	0.6	4.7	4.2	A
	Subtotal	990	719	72.6%	9.3	21.1	2.6	C
Total		2600	2272	87.4%	6.6	49.7	4.0	D

Intersection

San Fernando Street/Montgomery Street

Signalized

Direction	Movement	Volume (veh/hr)			GEH	Total Delay (sec/veh)		
		Demand	Served	% Served		Average	Std. Dev.	LOS
NB	Left Turn							
	Through							
	Right Turn							
	Subtotal							
SB	Left Turn	100	72	72.4%	3.0	33.1	3.1	C
	Through	1540	1211	78.6%	8.9	32.4	3.6	C
	Right Turn	30	24	79.0%	1.2	33.7	6.4	C
	Subtotal	1670	1307	78.2%	9.4	32.5	3.5	C
EB	Left Turn							
	Through	240	222	92.5%	1.2	33.3	8.6	C
	Right Turn	250	209	83.5%	2.7	25.8	7.9	C
	Subtotal	490	431	87.9%	2.8	29.7	8.1	C
WB	Left Turn	120	121	100.8%	0.1	104.5	18.4	F
	Through	370	395	106.6%	1.3	106.4	19.6	F
	Right Turn							
	Subtotal	490	516	105.2%	1.1	106.0	17.7	F
Total		2650	2253	85.0%	8.0	48.7	6.1	D

Intersection El Camino Real/Glenwood

Signalized

Direction	Movement	Volume (veh/hr)			GEH	Total Delay (sec/veh)		
		Demand	Served	% Served		Average	Std. Dev.	LOS
NB	Left Turn	140	117	83.6%	2.0	58.2	6.4	E
	Through	1570	1392	88.6%	4.6	32.7	2.8	C
	Right Turn	70	65	93.3%	0.6	28.1	3.0	C
	Subtotal	1780	1574	88.4%	5.0	34.4	2.9	C
SB	Left Turn	40	33	82.3%	1.2	61.7	14.5	E
	Through	1050	1045	99.5%	0.2	33.6	18.1	C
	Right Turn	270	272	100.7%	0.1	9.9	7.6	A
	Subtotal	1360	1350	99.2%	0.3	29.5	15.9	C
EB	Left Turn	320	321	100.4%	0.1	150.9	54.4	F
	Through	130	128	98.7%	0.1	155.3	56.8	F
	Right Turn	110	111	100.9%	0.1	113.4	54.6	F
	Subtotal	560	561	100.1%	0.0	144.5	55.0	F
WB	Left Turn	90	81	90.2%	1.0	45.2	6.8	D
	Through	170	166	97.5%	0.3	50.0	6.0	D
	Right Turn	130	127	97.9%	0.2	26.9	4.3	C
	Subtotal	390	374	95.9%	0.8	41.1	6.0	D
Total		4090	3859	94.3%	3.7	49.3	9.8	D

Intersection El Camino Real/Oak Grove

Signalized

Direction	Movement	Volume (veh/hr)			GEH	Total Delay (sec/veh)		
		Demand	Served	% Served		Average	Std. Dev.	LOS
NB	Left Turn	130	110	84.5%	1.8	41.4	3.2	D
	Through	1560	1378	88.4%	4.7	18.1	1.4	B
	Right Turn	130	117	89.8%	1.2	10.0	0.9	A
	Subtotal	1820	1605	88.2%	5.2	19.1	1.0	B
SB	Left Turn	140	130	92.7%	0.9	81.5	17.4	F
	Through	990	982	99.2%	0.3	68.5	35.0	E
	Right Turn	120	117	97.1%	0.3	55.6	31.9	E
	Subtotal	1250	1228	98.2%	0.6	68.6	32.7	E
EB	Left Turn	120	118	98.6%	0.2	130.5	54.7	F
	Through	220	219	99.4%	0.1	141.3	51.9	F
	Right Turn	140	138	98.5%	0.2	111.0	50.0	F
	Subtotal	480	475	98.9%	0.2	129.8	51.9	F
WB	Left Turn	110	105	95.5%	0.5	81.4	19.9	F
	Through	190	185	97.2%	0.4	59.7	8.5	E
	Right Turn	100	96	95.6%	0.4	32.1	6.0	C
	Subtotal	400	385	96.3%	0.7	58.6	9.7	E
Total		3950	3693	93.5%	4.2	53.9	12.7	D

Intersection El Camino Real/Santa Cruz Ave

Signalized

Direction	Movement	Volume (veh/hr)			GEH	Total Delay (sec/veh)		
		Demand	Served	% Served		Average	Std. Dev.	LOS
NB	Left Turn							
	Through	1480	1295	87.5%	5.0	5.4	0.9	A
	Right Turn	80	69	86.6%	1.2	3.9	0.6	A
	Subtotal	1560	1365	87.5%	5.1	5.4	0.8	A
SB	Left Turn							
	Through	1140	1122	98.4%	0.5	39.5	16.5	D
	Right Turn	100	97	97.2%	0.3	18.6	8.4	B
	Subtotal	1240	1219	98.3%	0.6	37.8	15.8	D
EB	Left Turn	180	175	97.2%	0.4	53.2	3.8	D
	Through	100	94	93.8%	0.6	50.3	3.8	D
	Right Turn	170	166	97.4%	0.3	31.4	6.5	C
	Subtotal	450	434	96.5%	0.7	44.3	3.9	D
WB	Left Turn	80	61	76.4%	2.3	78.3	5.8	E
	Through	180	149	82.6%	2.4	100.9	6.3	F
	Right Turn	160	125	77.9%	3.0	83.9	4.5	F
	Subtotal	420	334	79.6%	4.4	90.4	4.3	F
Total		3670	3352	91.3%	5.4	30.6	6.1	C

Intersection Merril St/Santa Cruz Ave

Unsignalized

Direction	Movement	Volume (veh/hr)			GEH	Total Delay (sec/veh)		
		Demand	Served	% Served		Average	Std. Dev.	LOS
NB	Left Turn	280	204	72.8%	4.9	77.5	9.0	F
	Through	20	15	75.5%	1.2	66.1	9.4	F
	Right Turn	10	7	71.0%	1.0	154.5	288.4	F
	Subtotal	310	226	72.9%	5.1	78.1	12.4	F
SB	Left Turn	10	9	92.0%	0.3	190.2	54.9	F
	Through	130	115	88.2%	1.4	188.6	51.9	F
	Right Turn	110	101	91.9%	0.9	188.7	52.1	F
	Subtotal	250	225	90.0%	1.6	188.7	51.8	F
EB	Left Turn	110	100	91.0%	1.0	24.3	5.6	C
	Through	40	35	87.3%	0.8	26.0	4.9	D
	Right Turn	30	30	99.3%	0.0	20.2	6.3	C
	Subtotal	180	165	91.6%	1.2	23.9	5.4	C
WB	Left Turn	10	10	95.0%	0.2	27.3	16.6	D
	Through	30	28	94.7%	0.3	43.1	9.5	E
	Right Turn	30	31	104.7%	0.3	20.7	6.0	C
	Subtotal	70	69	99.0%	0.1	30.5	5.5	D
Total		810	685	84.6%	4.6	96.4	19.7	F

Intersection Ravenswood Ave/Laurel St

Signalized

Direction	Movement	Volume (veh/hr)			GEH	Total Delay (sec/veh)		
		Demand	Served	% Served		Average	Std. Dev.	LOS
NB	Left Turn	190	186	97.8%	0.3	73.6	46.1	E
	Through	140	140	99.6%	0.0	50.4	37.6	D
	Right Turn	50	51	102.6%	0.2	42.3	32.8	D
	Subtotal	380	377	99.1%	0.2	60.7	41.0	E
SB	Left Turn	60	61	102.2%	0.2	70.8	40.6	E
	Through	130	128	98.4%	0.2	68.3	44.1	E
	Right Turn	80	80	100.0%	0.0	58.0	44.2	E
	Subtotal	270	269	99.7%	0.0	65.9	43.3	E
EB	Left Turn	80	68	84.9%	1.4	83.6	23.3	F
	Through	850	704	82.8%	5.2	26.8	2.1	C
	Right Turn	130	107	81.9%	2.2	23.3	2.1	C
	Subtotal	1060	878	82.9%	5.8	30.7	2.7	C
WB	Left Turn	40	41	102.3%	0.1	95.2	43.1	F
	Through	590	571	96.7%	0.8	60.6	45.9	E
	Right Turn	160	158	98.9%	0.1	57.2	46.7	E
	Subtotal	790	770	97.5%	0.7	61.8	45.8	E
Total		2500	2294	91.8%	4.2	50.1	26.8	D

Intersection Main Street/Maple Street

Unsignalized

Direction	Movement	Volume (veh/hr)			GEH	Total Delay (sec/veh)		
		Demand	Served	% Served		Average	Std. Dev.	LOS
NB	Left Turn							
	Through	470	379	80.7%	4.4	36.9	4.4	E
	Right Turn							
	Subtotal	470	379	80.7%	4.4	36.9	4.4	E
SB	Left Turn							
	Through	500	411	82.1%	4.2	26.7	3.8	D
	Right Turn							
	Subtotal	500	411	82.1%	4.2	26.7	3.8	D
EB	Left Turn							
	Through							
	Right Turn							
	Subtotal							
WB	Left Turn							
	Through							
	Right Turn	20	23	113.5%	0.6	30.9	14.4	D
	Subtotal	20	23	113.5%	0.6	30.9	14.4	D
Total		990	813	82.1%	5.9	31.5	3.4	D

Intersection Main Street/Beech Street

Unsignalized

Direction	Movement	Volume (veh/hr)			GEH	Total Delay (sec/veh)		
		Demand	Served	% Served		Average	Std. Dev.	LOS
NB	Left Turn	80	73	90.9%	0.8	57.7	44.7	F
	Through	240	226	94.3%	0.9	59.9	50.1	F
	Right Turn							
	Subtotal	320	299	93.4%	1.2	59.3	48.4	F
SB	Left Turn							
	Through	360	296	82.3%	3.5	3.0	3.5	A
	Right Turn	10	8	77.0%	0.8	3.2	6.2	A
	Subtotal	370	304	82.1%	3.6	3.0	3.6	A
EB	Left Turn	60	56	94.0%	0.5	20.8	14.7	C
	Through							
	Right Turn	20	18	92.0%	0.4	10.7	8.4	B
	Subtotal	80	75	93.5%	0.6	18.2	12.6	C
WB	Left Turn							
	Through							
	Right Turn							
	Subtotal							
Total		770	678	88.0%	3.4	29.7	23.5	D

Intersection Main Street/Middlefield Road

Signalized

Direction	Movement	Volume (veh/hr)			GEH	Total Delay (sec/veh)		
		Demand	Served	% Served		Average	Std. Dev.	LOS
NB	Left Turn	60	49	81.3%	1.5	158.0	31.7	F
	Through	400	323	80.6%	4.1	81.8	8.8	F
	Right Turn	30	29	95.7%	0.2	85.7	40.2	F
	Subtotal	490	400	81.6%	4.3	92.1	7.5	F
SB	Left Turn	100	86	85.6%	1.5	151.8	62.7	F
	Through	360	294	81.7%	3.6	266.9	60.1	F
	Right Turn	60	46	77.0%	1.9	33.9	9.6	C
	Subtotal	520	426	81.9%	4.3	219.2	41.1	F
EB	Left Turn	90	66	73.2%	2.7	355.3	31.5	F
	Through	390	274	70.3%	6.4	426.5	33.7	F
	Right Turn	90	67	74.6%	2.6	522.5	45.7	F
	Subtotal	570	407	71.4%	7.4	430.5	33.8	F
WB	Left Turn	50	48	95.0%	0.4	12.4	5.7	B
	Through	580	511	88.0%	3.0	8.3	0.7	A
	Right Turn	100	90	90.1%	1.0	0.4	0.1	A
	Subtotal	730	648	88.8%	3.1	7.5	0.7	A
Total		2310	1881	81.4%	9.4	164.8	6.9	F

Intersection Fair Oaks Lane/Middlefield Road

Unsignalized

Direction	Movement	Volume (veh/hr)			GEH	Total Delay (sec/veh)		
		Demand	Served	% Served		Average	Std. Dev.	LOS
NB	Left Turn	30	3	10.3%	6.6	117.0	63.8	F
	Through	20	3	13.5%	5.1	110.4	157.8	F
	Right Turn	130	20	15.3%	12.7	29.9	37.1	D
	Subtotal	180	26	14.3%	15.2	47.9	47.5	E
SB	Left Turn	10	1	10.0%	3.8	148.5	194.0	F
	Through	20	4	18.0%	4.8	112.8	139.7	F
	Right Turn	10	2	18.0%	3.4	53.4	111.7	F
	Subtotal	40	6	16.0%	7.0	108.7	136.2	F
EB	Left Turn	20	4	18.0%	4.8	11.1	5.1	B
	Through	670	116	17.2%	28.0	4.2	2.3	A
	Right Turn	40	6	13.8%	7.2	2.6	1.5	A
	Subtotal	730	125	17.1%	29.3	4.4	2.3	A
WB	Left Turn	190	31	16.4%	15.1	15.0	3.1	B
	Through	910	141	15.4%	33.6	5.9	0.8	A
	Right Turn	20	5	23.5%	4.4	4.0	2.2	A
	Subtotal	1120	176	15.7%	37.1	7.4	0.8	A
Total		2070	333	16.1%	50.1	10.7	5.0	B

Intersection Watkins Avenue/Middlefield Road

Unsignalized

Direction	Movement	Volume (veh/hr)			GEH	Total Delay (sec/veh)		
		Demand	Served	% Served		Average	Std. Dev.	LOS
NB	Left Turn	60	8	13.3%	8.9	103.1	56.0	F
	Through							
	Right Turn	60	9	14.7%	8.7	35.9	40.3	E
	Subtotal	120	17	14.0%	12.5	68.3	48.1	F
SB	Left Turn							
	Through							
	Right Turn							
	Subtotal							
EB	Left Turn							
	Through	670	110	16.4%	28.4	5.1	0.8	A
	Right Turn	140	24	17.1%	12.8	3.9	1.0	A
	Subtotal	810	134	16.5%	31.1	4.8	0.7	A
WB	Left Turn	80	13	16.8%	9.7	18.7	4.1	C
	Through	1060	168	15.8%	36.0	8.0	0.4	A
	Right Turn							
	Subtotal	1140	181	15.9%	37.3	8.7	0.4	A
Total		2070	332	16.0%	50.2	10.3	2.9	B

Intersection

Linden Avenue-Glenwood Avenue/Middlefield Road

Signalized

Direction	Movement	Volume (veh/hr)			GEH	Total Delay (sec/veh)		
		Demand	Served	% Served		Average	Std. Dev.	LOS
NB	Left Turn	150	23	15.3%	13.7	33.8	9.2	C
	Through	20	3	14.0%	5.1	55.2	63.7	E
	Right Turn	110	18	16.7%	11.4	13.2	4.8	B
	Subtotal	280	44	15.8%	18.5	26.1	7.7	C
SB	Left Turn	30	4	12.0%	6.4	23.9	9.6	C
	Through	10	2	19.0%	3.3	25.2	18.0	C
	Right Turn	100	17	16.5%	10.9	15.2	2.9	B
	Subtotal	140	22	15.7%	13.1	17.1	3.7	B
EB	Left Turn	50	7	13.6%	8.1	41.3	14.0	D
	Through	550	89	16.1%	25.8	16.5	2.2	B
	Right Turn	130	23	17.7%	12.2	13.2	3.0	B
	Subtotal	730	118	16.2%	29.7	17.3	2.7	B
WB	Left Turn	190	32	16.6%	15.0	51.4	19.8	D
	Through	890	141	15.9%	33.0	23.4	9.5	C
	Right Turn	90	11	12.7%	11.0	19.8	10.4	B
	Subtotal	1170	184	15.7%	37.9	28.0	11.0	C
Total		2320	369	15.9%	53.2	23.8	6.0	C

2040 No Project



Intersection Pennsylvania Street/22nd Street

Unsignalized

Direction	Movement	Volume (veh/hr)			GEH	Total Delay (sec/veh)		
		Demand	Served	% Served		Average	Std. Dev.	LOS
NB	Left Turn	60	57	94.8%	0.4	13.7	2.8	B
	Through	170	164	96.4%	0.5	14.1	1.9	B
	Right Turn	60	63	105.2%	0.4	12.0	1.6	B
	Subtotal	290	284	97.9%	0.4	13.5	1.7	B
SB	Left Turn	30	29	96.0%	0.2	9.1	1.2	A
	Through	80	77	96.5%	0.3	10.1	1.4	B
	Right Turn	20	23	116.5%	0.7	7.2	1.3	A
	Subtotal	130	129	99.5%	0.1	9.4	1.1	A
EB	Left Turn	10	9	92.0%	0.3	7.0	1.5	A
	Through	20	20	100.0%	0.0	8.1	1.6	A
	Right Turn	70	67	95.3%	0.4	6.1	1.2	A
	Subtotal	100	96	95.9%	0.4	6.7	1.1	A
WB	Left Turn	70	69	99.1%	0.1	8.7	1.1	A
	Through	30	33	109.7%	0.5	7.7	0.7	A
	Right Turn	20	20	99.5%	0.0	6.8	1.2	A
	Subtotal	120	122	101.8%	0.2	8.1	0.8	A
Total		640	631	98.6%	0.3	10.6	1.0	B

Intersection Indiana Street/22nd Street

Unsignalized

Direction	Movement	Volume (veh/hr)			GEH	Total Delay (sec/veh)		
		Demand	Served	% Served		Average	Std. Dev.	LOS
NB	Left Turn	10	10	97.0%	0.1	7.4	1.8	A
	Through	70	70	99.9%	0.0	8.6	0.3	A
	Right Turn	50	50	100.6%	0.0	5.8	0.6	A
	Subtotal	130	130	99.9%	0.0	7.4	0.4	A
SB	Left Turn	10	10	103.0%	0.1	6.4	1.6	A
	Through	20	23	117.0%	0.7	7.0	0.7	A
	Right Turn	10	11	107.0%	0.2	4.7	1.2	A
	Subtotal	40	44	111.0%	0.7	6.3	0.8	A
EB	Left Turn	20	18	89.5%	0.5	5.8	1.0	A
	Through	80	86	107.9%	0.7	6.2	0.3	A
	Right Turn	20	21	105.5%	0.2	4.5	0.7	A
	Subtotal	120	125	104.4%	0.5	5.8	0.3	A
WB	Left Turn	10	8	79.0%	0.7	5.9	1.2	A
	Through	70	69	98.1%	0.2	6.0	0.3	A
	Right Turn	10	12	120.0%	0.6	4.2	1.3	A
	Subtotal	90	89	98.4%	0.1	5.7	0.3	A
Total		380	388	102.2%	0.4	6.4	0.2	A

Intersection Tunnel Avenue/Blanken Avenue

Unsignalized

Direction	Movement	Volume (veh/hr)			GEH	Total Delay (sec/veh)		
		Demand	Served	% Served		Average	Std. Dev.	LOS
NB	Left Turn	70	67	96.0%	0.3	75.1	32.9	F
	Through	210	205	97.8%	0.3	79.7	36.4	F
	Right Turn	20	21	107.0%	0.3	77.5	36.5	F
	Subtotal	300	294	98.0%	0.4	78.5	35.5	F
SB	Left Turn	90	85	94.1%	0.6	36.8	11.1	E
	Through	160	158	98.8%	0.2	39.5	10.2	E
	Right Turn	10	11	109.0%	0.3	34.2	12.8	D
	Subtotal	260	254	97.6%	0.4	38.3	10.3	E
EB	Left Turn	20	15	74.0%	1.2	167.2	21.8	F
	Through	240	197	82.1%	2.9	167.9	14.5	F
	Right Turn	190	155	81.4%	2.7	164.3	18.2	F
	Subtotal	450	367	81.4%	4.1	166.3	16.3	F
WB	Left Turn	20	17	86.5%	0.6	184.8	44.4	F
	Through	270	242	89.5%	1.8	180.5	35.7	F
	Right Turn	110	101	91.5%	0.9	178.6	35.9	F
	Subtotal	400	360	89.9%	2.1	180.1	35.5	F
Total		1410	1274	90.3%	3.7	124.8	9.8	F

Intersection Dubuque Avenue/Grand Avenue

Signalized

Direction	Movement	Volume (veh/hr)			GEH	Total Delay (sec/veh)		
		Demand	Served	% Served		Average	Std. Dev.	LOS
NB	Left Turn							
	Through							
	Right Turn							
	Subtotal							
SB	Left Turn	40	38	94.5%	0.4	27.4	3.9	C
	Through							
	Right Turn	60	60	99.7%	0.0	9.1	0.4	A
	Subtotal	100	98	97.6%	0.2	16.1	1.4	B
EB	Left Turn	40	38	95.8%	0.3	31.5	1.7	C
	Through	650	643	98.9%	0.3	9.3	0.7	A
	Right Turn							
	Subtotal	690	681	98.8%	0.3	10.6	0.6	B
WB	Left Turn							
	Through	520	509	98.0%	0.5	14.2	1.1	B
	Right Turn	40	39	97.0%	0.2	10.7	2.5	B
	Subtotal	560	548	97.9%	0.5	14.0	1.2	B
Total		1350	1327	98.3%	0.6	12.4	0.6	B

Intersection **Linden Avenue-San Mateo Avenue/San Mateo Avenue** Signalized

Direction	Movement	Volume (veh/hr)			GEH	Total Delay (sec/veh)		
		Demand	Served	% Served		Average	Std. Dev.	LOS
NB	Left Turn							
	Through	260	244	93.7%	1.0	56.4	36.4	E
	Right Turn	310	308	99.2%	0.1	10.2	8.6	B
	Subtotal	570	551	96.7%	0.8	30.4	20.2	C
SB	Left Turn	150	150	100.2%	0.0	71.5	30.9	E
	Through	270	273	101.0%	0.2	5.7	1.1	A
	Right Turn							
	Subtotal	420	423	100.7%	0.1	28.9	10.6	C
EB	Left Turn							
	Through							
	Right Turn							
	Subtotal							
WB	Left Turn	240	242	100.8%	0.1	22.6	7.6	C
	Through							
	Right Turn	160	164	102.5%	0.3	24.2	14.0	C
	Subtotal	400	406	101.5%	0.3	23.2	9.3	C
Total		1390	1380	99.3%	0.3	27.9	13.3	C

Intersection **Herman Street/Scott Street** Unsignalized

Direction	Movement	Volume (veh/hr)			GEH	Total Delay (sec/veh)		
		Demand	Served	% Served		Average	Std. Dev.	LOS
NB	Left Turn	10	9	90.0%	0.3	25.7	12.5	D
	Through	200	201	100.3%	0.0	27.5	9.4	D
	Right Turn	240	236	98.5%	0.2	25.3	8.6	D
	Subtotal	450	446	99.1%	0.2	26.3	8.9	D
SB	Left Turn	60	57	95.5%	0.4	13.7	2.2	B
	Through	170	170	100.2%	0.0	12.9	1.5	B
	Right Turn	10	10	100.0%	0.0	9.6	2.2	A
	Subtotal	240	238	99.0%	0.1	12.9	1.5	B
EB	Left Turn	10	10	99.0%	0.0	9.3	2.3	A
	Through	40	40	100.5%	0.0	12.1	1.2	B
	Right Turn	10	10	101.0%	0.0	5.4	1.7	A
	Subtotal	60	60	100.3%	0.0	10.5	1.4	B
WB	Left Turn	90	85	94.9%	0.5	0.3	0.1	A
	Through	10	11	108.0%	0.2	0.7	0.2	A
	Right Turn	90	94	103.9%	0.4	0.2	0.1	A
	Subtotal	190	190	99.8%	0.0	0.3	0.1	A
Total		940	933	99.3%	0.2	16.6	4.3	C

Intersection **Montgomery Avenue/Scott Street**

Unsignalized

Direction	Movement	Volume (veh/hr)			GEH	Total Delay (sec/veh)		
		Demand	Served	% Served		Average	Std. Dev.	LOS
NB	Left Turn	20	20	97.5%	0.1	8.5	1.7	A
	Through	10	11	109.0%	0.3	9.9	2.3	A
	Right Turn	20	18	91.0%	0.4	4.3	0.9	A
	Subtotal	50	49	97.2%	0.2	7.2	1.0	A
SB	Left Turn	10	8	76.0%	0.8	8.4	3.4	A
	Through	10	12	123.0%	0.7	8.3	1.6	A
	Right Turn	20	19	96.5%	0.2	3.5	0.5	A
	Subtotal	40	39	98.0%	0.1	6.0	1.2	A
EB	Left Turn	60	58	95.8%	0.3	2.4	0.2	A
	Through	240	236	98.4%	0.3	0.9	0.2	A
	Right Turn	40	41	102.0%	0.1	0.5	0.2	A
	Subtotal	340	334	98.4%	0.3	1.1	0.2	A
WB	Left Turn	10	10	103.0%	0.1	2.1	0.6	A
	Through	150	151	100.3%	0.0	0.4	0.1	A
	Right Turn	10	11	112.0%	0.4	0.2	0.1	A
	Subtotal	170	172	101.2%	0.2	0.5	0.1	A
Total		600	594	99.0%	0.2	1.8	0.3	A

Intersection **Driveway-Dollar Avenue/Linden Avenue**

Signalized

Direction	Movement	Volume (veh/hr)			GEH	Total Delay (sec/veh)		
		Demand	Served	% Served		Average	Std. Dev.	LOS
NB	Left Turn	120	120	99.6%	0.0	218.2	111.0	F
	Through							
	Right Turn	110	113	102.5%	0.3	205.2	104.7	F
	Subtotal	230	232	101.0%	0.1	211.6	107.7	F
SB	Left Turn	10	12	115.0%	0.5	86.6	19.0	F
	Through							
	Right Turn							
	Subtotal	10	12	115.0%	0.5	86.6	19.0	F
EB	Left Turn							
	Through	300	302	100.5%	0.1	86.8	21.9	F
	Right Turn	120	121	100.8%	0.1	75.4	20.4	E
	Subtotal	420	423	100.6%	0.1	83.5	21.0	F
WB	Left Turn	100	97	97.4%	0.3	5.0	2.6	A
	Through	305	296	97.0%	0.5	6.0	1.4	A
	Right Turn	15	13	86.7%	0.5	0.2	0.1	A
	Subtotal	420	406	96.7%	0.7	5.5	1.3	A
Total		1080	1072	99.3%	0.2	81.8	24.2	F

Intersection

San Mateo Avenue/San Bruno Avenue

Signalized

Direction	Movement	Volume (veh/hr)			GEH	Total Delay (sec/veh)		
		Demand	Served	% Served		Average	Std. Dev.	LOS
NB	Left Turn	50	47	93.6%	0.5	48.0	9.0	D
	Through	280	281	100.3%	0.1	43.2	6.2	D
	Right Turn	160	165	103.0%	0.4	23.2	5.6	C
	Subtotal	490	493	100.5%	0.1	36.9	5.9	D
SB	Left Turn	120	114	95.3%	0.5	50.2	4.2	D
	Through	110	112	101.9%	0.2	30.5	3.5	C
	Right Turn	90	87	96.2%	0.4	21.3	3.2	C
	Subtotal	320	313	97.8%	0.4	35.1	3.1	D
EB	Left Turn	50	49	98.6%	0.1	22.0	4.5	C
	Through	370	376	101.7%	0.3	9.3	0.8	A
	Right Turn	10	10	101.0%	0.0	4.7	4.7	A
	Subtotal	430	436	101.3%	0.3	10.6	0.9	B
WB	Left Turn	300	292	97.3%	0.5	61.9	5.8	E
	Through	560	569	101.5%	0.4	32.9	2.6	C
	Right Turn	200	198	98.9%	0.2	30.8	3.7	C
	Subtotal	1060	1058	99.8%	0.1	40.6	3.4	D
Total		2300	2300	100.0%	0.0	33.3	1.7	C

Intersection **El Camino Real/Millbrae Avenue**

Signalized

Direction	Movement	Volume (veh/hr)			GEH	Total Delay (sec/veh)		
		Demand	Served	% Served		Average	Std. Dev.	LOS
NB	Left Turn	50	50	99.2%	0.1	74.6	3.9	E
	Through	1220	1206	98.8%	0.4	52.5	2.0	D
	Right Turn	630	625	99.1%	0.2	6.6	0.7	A
	Subtotal	1900	1880	98.9%	0.5	37.8	1.4	D
SB	Left Turn	750	654	87.2%	3.6	212.7	11.9	F
	Through	1340	1200	89.6%	3.9	50.9	4.4	D
	Right Turn	40	36	89.0%	0.7	53.3	5.2	D
	Subtotal	2130	1890	88.7%	5.4	107.0	7.6	F
EB	Left Turn	60	48	80.2%	1.6	367.5	29.4	F
	Through	810	722	89.1%	3.2	312.3	42.5	F
	Right Turn	100	87	86.8%	1.4	329.5	46.3	F
	Subtotal	970	857	88.3%	3.8	317.2	41.9	F
WB	Left Turn	520	469	90.2%	2.3	203.3	75.1	F
	Through	230	228	99.2%	0.1	15.3	3.0	B
	Right Turn	500	485	97.0%	0.7	14.4	1.2	B
	Subtotal	1250	1182	94.6%	1.9	89.8	29.9	F
Total		6250	5808	92.9%	5.7	112.0	6.2	F

Intersection **Rollins Road/Millbrae Avenue**

Signalized

Direction	Movement	Volume (veh/hr)			GEH	Total Delay (sec/veh)		
		Demand	Served	% Served		Average	Std. Dev.	LOS
NB	Left Turn	130	103	79.2%	2.5	96.7	48.4	F
	Through	260	199	76.4%	4.0	326.3	19.6	F
	Right Turn	280	210	75.1%	4.5	247.5	17.2	F
	Subtotal	670	512	76.4%	6.5	247.6	17.6	F
SB	Left Turn	310	312	100.8%	0.1	60.3	2.6	E
	Through	60	60	99.3%	0.1	55.4	6.8	E
	Right Turn	120	122	101.8%	0.2	13.8	6.8	B
	Subtotal	490	494	100.8%	0.2	48.3	1.9	D
EB	Left Turn	490	456	93.1%	1.5	86.1	10.9	F
	Through	1310	1204	91.9%	3.0	32.8	2.3	C
	Right Turn	390	347	88.9%	2.3	20.3	2.5	C
	Subtotal	2190	2007	91.6%	4.0	42.8	4.0	D
WB	Left Turn	600	599	99.8%	0.0	125.9	29.6	F
	Through	1000	983	98.3%	0.5	65.6	11.2	E
	Right Turn	470	474	100.8%	0.2	8.2	2.2	A
	Subtotal	2070	2056	99.3%	0.3	70.0	13.9	E
Total		5420	5069	93.5%	4.9	74.9	7.1	E

Intersection California Drive/Oak Grove Avenue

Signalized

Direction	Movement	Volume (veh/hr)			GEH	Total Delay (sec/veh)		
		Demand	Served	% Served		Average	Std. Dev.	LOS
NB	Left Turn	30	28	92.0%	0.4	83.8	16.2	F
	Through	650	624	96.0%	1.0	59.7	16.5	E
	Right Turn	230	215	93.3%	1.0	33.5	13.7	C
	Subtotal	910	866	95.2%	1.5	54.0	15.9	D
SB	Left Turn	320	253	78.9%	4.0	208.2	16.9	F
	Through	660	532	80.7%	5.2	65.9	6.0	E
	Right Turn	70	57	80.9%	1.7	15.9	2.9	B
	Subtotal	1050	842	80.1%	6.8	105.4	9.9	F
EB	Left Turn	60	35	57.5%	3.7	395.9	45.1	F
	Through	310	183	59.1%	8.1	415.3	36.4	F
	Right Turn	250	154	61.4%	6.8	398.0	31.9	F
	Subtotal	620	371	59.9%	11.2	406.1	35.0	F
WB	Left Turn	165	70	42.6%	8.7	42.4	3.5	D
	Through	300	126	42.0%	11.9	39.0	2.6	D
	Right Turn	185	82	44.1%	9.0	20.6	4.4	C
	Subtotal	650	278	42.8%	17.3	34.5	1.7	C
Total		3230	2357	73.0%	16.5	125.3	8.5	F

Intersection Carolan Avenue/Oak Grove Avenue

Unsignalized

Direction	Movement	Volume (veh/hr)			GEH	Total Delay (sec/veh)		
		Demand	Served	% Served		Average	Std. Dev.	LOS
NB	Left Turn	90	48	53.1%	5.1	616.5	80.6	F
	Through	180	89	49.2%	7.9	582.8	101.0	F
	Right Turn	60	26	43.5%	5.2	582.0	95.5	F
	Subtotal	330	162	49.2%	10.7	591.4	91.0	F
SB	Left Turn	90	32	35.9%	7.4	193.3	16.8	F
	Through	110	38	34.3%	8.4	197.6	11.8	F
	Right Turn	430	159	37.0%	15.8	469.5	26.2	F
	Subtotal	630	229	36.4%	19.3	385.9	19.5	F
EB	Left Turn	410	309	75.3%	5.3	0.5	0.1	A
	Through	140	121	86.2%	1.7	1.9	0.8	A
	Right Turn	310	234	75.5%	4.6	0.4	0.1	A
	Subtotal	860	664	77.2%	7.1	0.7	0.2	A
WB	Left Turn	30	13	44.0%	3.6	695.7	107.1	F
	Through	130	54	41.7%	7.9	716.5	92.7	F
	Right Turn	140	60	42.8%	8.0	667.4	97.2	F
	Subtotal	300	127	42.4%	11.8	691.8	95.4	F
Total		2120	1183	55.8%	23.1	229.0	8.8	F

Intersection California Drive/North Lane

Unsignalized

Direction	Movement	Volume (veh/hr)			GEH	Total Delay (sec/veh)		
		Demand	Served	% Served		Average	Std. Dev.	LOS
NB	Left Turn							
	Through	1010	1016	100.6%	0.2	1.7	0.1	A
	Right Turn	300	292	97.2%	0.5	3.3	0.8	A
	Subtotal	1310	1307	99.8%	0.1	2.1	0.3	A
SB	Left Turn	200	148	74.2%	3.9	89.5	77.7	F
	Through	930	666	71.6%	9.3	5.1	4.6	A
	Right Turn							
	Subtotal	1130	814	72.1%	10.1	20.9	19.0	C
EB	Left Turn							
	Through							
	Right Turn							
	Subtotal							
WB	Left Turn	80	50	62.1%	3.8	82.7	22.8	F
	Through							
	Right Turn	180	124	69.1%	4.5	6.4	1.8	A
	Subtotal	260	174	67.0%	5.8	28.4	8.1	D
Total		2700	2295	85.0%	8.1	10.8	7.3	B

Intersection Carolan Avenue/North Lane

Unsignalized

Direction	Movement	Volume (veh/hr)			GEH	Total Delay (sec/veh)		
		Demand	Served	% Served		Average	Std. Dev.	LOS
NB	Left Turn	120	91	76.2%	2.8	252.2	103.6	F
	Through	230	171	74.3%	4.2	125.5	47.0	F
	Right Turn	20	14	71.5%	1.4	123.7	61.9	F
	Subtotal	370	277	74.7%	5.2	167.7	67.2	F
SB	Left Turn	10	7	67.0%	1.1	226.9	126.1	F
	Through	200	127	63.7%	5.7	226.7	145.9	F
	Right Turn	140	81	57.8%	5.6	206.6	156.0	F
	Subtotal	350	215	61.4%	8.0	218.9	148.8	F
EB	Left Turn	330	288	87.3%	2.4	2.2	0.4	A
	Through	20	25	124.0%	1.0	1.1	0.4	A
	Right Turn	150	135	89.7%	1.3	1.2	0.7	A
	Subtotal	500	447	89.5%	2.4	1.9	0.4	A
WB	Left Turn							
	Through							
	Right Turn							
	Subtotal							
Total		1220	939	77.0%	8.6	97.9	39.5	F

Intersection Anita Road/Peninsula Avenue

Unsignalized

Direction	Movement	Volume (veh/hr)			GEH	Total Delay (sec/veh)		
		Demand	Served	% Served		Average	Std. Dev.	LOS
NB	Left Turn							
	Through							
	Right Turn							
	Subtotal							
SB	Left Turn	40	37	91.8%	0.5	29.5	10.1	D
	Through							
	Right Turn	30	29	97.3%	0.1	29.3	11.6	D
	Subtotal	70	66	94.1%	0.5	29.1	8.9	D
EB	Left Turn	60	60	100.7%	0.1	11.7	2.3	B
	Through	600	615	102.5%	0.6	1.2	0.4	A
	Right Turn							
	Subtotal	660	676	102.3%	0.6	2.2	0.5	A
WB	Left Turn							
	Through	590	595	100.9%	0.2	7.6	1.7	A
	Right Turn	70	73	104.0%	0.3	6.1	1.5	A
	Subtotal	660	668	101.2%	0.3	7.4	1.7	A
Total		1390	1410	101.4%	0.5	6.0	1.0	A

Intersection Woodside Way/Villa Terrace

Unsignalized

Direction	Movement	Volume (veh/hr)			GEH	Total Delay (sec/veh)		
		Demand	Served	% Served		Average	Std. Dev.	LOS
NB	Left Turn	10	8	81.0%	0.6	4.7	0.6	A
	Through	30	29	96.3%	0.2	5.9	0.2	A
	Right Turn	10	10	98.0%	0.1	2.8	0.5	A
	Subtotal	50	47	93.6%	0.5	5.1	0.3	A
SB	Left Turn	10	9	86.0%	0.5	5.6	0.5	A
	Through	20	26	132.0%	1.3	6.2	0.7	A
	Right Turn	60	55	91.5%	0.7	3.3	0.2	A
	Subtotal	90	90	99.9%	0.0	4.3	0.3	A
EB	Left Turn	50	48	96.2%	0.3	2.1	0.2	A
	Through	30	34	112.7%	0.7	0.8	0.2	A
	Right Turn	10	13	131.0%	0.9	0.3	0.3	A
	Subtotal	90	95	105.6%	0.5	1.4	0.1	A
WB	Left Turn	10	9	91.0%	0.3	1.8	0.2	A
	Through	20	21	102.5%	0.1	0.4	0.2	A
	Right Turn	20	19	95.5%	0.2	0.2	0.1	A
	Subtotal	50	49	97.4%	0.2	0.6	0.1	A
Total		280	280	100.1%	0.0	2.8	0.1	A

Intersection N. San Mateo Drive/Villa Terrace

Unsignalized

Direction	Movement	Volume (veh/hr)			GEH	Total Delay (sec/veh)		
		Demand	Served	% Served		Average	Std. Dev.	LOS
NB	Left Turn	20	21	107.0%	0.3	5.3	1.1	A
	Through	470	464	98.8%	0.3	0.7	0.1	A
	Right Turn	40	45	111.5%	0.7	0.7	0.1	A
	Subtotal	530	530	100.0%	0.0	0.8	0.1	A
SB	Left Turn	20	21	104.0%	0.2	5.8	0.8	A
	Through	550	560	101.7%	0.4	2.4	0.2	A
	Right Turn	20	21	103.5%	0.2	2.5	0.3	A
	Subtotal	590	601	101.9%	0.5	2.5	0.2	A
EB	Left Turn	10	8	84.0%	0.5	14.4	5.8	B
	Through	30	28	94.0%	0.3	15.3	2.3	C
	Right Turn	20	21	104.0%	0.2	6.3	2.1	A
	Subtotal	60	57	95.7%	0.3	11.9	2.6	B
WB	Left Turn	40	35	87.0%	0.9	11.9	1.8	B
	Through	30	30	101.0%	0.1	15.9	2.7	C
	Right Turn	20	19	94.5%	0.2	6.9	2.2	A
	Subtotal	90	84	93.3%	0.6	12.2	1.6	B
Total		1270	1273	100.2%	0.1	2.9	0.2	A

Intersection Arundel Road/Peninsula Avenue

Unsignalized

Direction	Movement	Volume (veh/hr)			GEH	Total Delay (sec/veh)		
		Demand	Served	% Served		Average	Std. Dev.	LOS
NB	Left Turn	30	26	87.3%	0.7	34.5	8.9	D
	Through	10	12	122.0%	0.7	27.6	10.2	D
	Right Turn	60	62	102.8%	0.2	15.5	6.2	C
	Subtotal	100	100	100.1%	0.0	22.0	6.8	C
SB	Left Turn	20	20	100.0%	0.0	20.2	4.1	C
	Through	10	10	100.0%	0.0	19.2	5.8	C
	Right Turn	10	12	122.0%	0.7	12.7	7.2	B
	Subtotal	40	42	105.5%	0.3	18.1	3.5	C
EB	Left Turn	10	11	113.0%	0.4	5.4	1.7	A
	Through	590	608	103.1%	0.7	0.7	0.1	A
	Right Turn	40	36	88.8%	0.7	0.6	0.1	A
	Subtotal	640	655	102.3%	0.6	0.7	0.1	A
WB	Left Turn	40	41	102.5%	0.2	7.1	1.1	A
	Through	620	607	97.9%	0.5	3.9	0.8	A
	Right Turn	30	29	96.3%	0.2	2.5	0.7	A
	Subtotal	690	677	98.1%	0.5	4.0	0.8	A
Total		1470	1474	100.3%	0.1	4.2	0.6	A

SimTraffic Post-Processor
Average Results from 20 Runs
Volume and Delay by Movement

Caltrain Electrification
2040 No Project Conditions
AM Peak Hour

Intersection **Railroad Ave/1st Ave**

Unsignalized

Direction	Movement	Volume (veh/hr)			GEH	Total Delay (sec/veh)		
		Demand	Served	% Served		Average	Std. Dev.	LOS
NB	Left Turn	10	3	33.0%	2.6	2562.3	1465.9	F
	Through	10	4	38.0%	2.4	2439.2	1839.3	F
	Right Turn	10	3	29.0%	2.8	3116.6	2950.1	F
	Subtotal	30	10	33.3%	4.5	2242.8	1456.6	F
SB	Left Turn							
	Through							
	Right Turn							
	Subtotal							
EB	Left Turn	20	19	96.0%	0.2	12.9	7.9	B
	Through	100	100	100.3%	0.0	1.0	0.2	A
	Right Turn							
	Subtotal	120	120	99.6%	0.0	3.0	1.4	A
WB	Left Turn							
	Through	260	207	79.7%	3.5	122.6	10.9	F
	Right Turn	10	7	73.0%	0.9	88.9	31.5	F
	Subtotal	270	214	79.4%	3.6	121.4	10.1	F
Total		420	344	81.9%	3.9	119.3	24.6	F

Intersection **S. B. St/1st Ave**

Signalized

Direction	Movement	Volume (veh/hr)			GEH	Total Delay (sec/veh)		
		Demand	Served	% Served		Average	Std. Dev.	LOS
NB	Left Turn	30	29	98.0%	0.1	31.3	10.4	C
	Through	250	244	97.8%	0.4	18.4	5.4	B
	Right Turn	20	20	101.0%	0.0	19.3	8.5	B
	Subtotal	300	294	98.0%	0.3	19.7	5.7	B
SB	Left Turn	30	26	85.3%	0.8	39.5	11.7	D
	Through	430	393	91.3%	1.8	21.3	3.9	C
	Right Turn	10	9	89.0%	0.4	23.3	12.7	C
	Subtotal	470	427	90.9%	2.0	22.4	4.4	C
EB	Left Turn	10	11	109.0%	0.3	154.3	66.8	F
	Through	90	95	105.3%	0.5	148.1	66.7	F
	Right Turn	40	41	101.8%	0.1	120.0	61.6	F
	Subtotal	140	146	104.6%	0.5	140.4	64.5	F
WB	Left Turn	20	17	86.5%	0.6	91.7	25.8	F
	Through	120	100	83.5%	1.9	86.0	8.7	F
	Right Turn	90	71	79.1%	2.1	64.1	7.5	E
	Subtotal	230	189	82.0%	2.9	78.4	9.2	E
Total		1140	1056	92.6%	2.5	48.4	12.7	D

SimTraffic Post-Processor
Average Results from 20 Runs
Volume and Delay by Movement

Caltrain Electrification
2040 No Project Conditions
AM Peak Hour

Intersection

Transit Center Way/1st St

Unsignalized

Direction	Movement	Volume (veh/hr)			GEH	Total Delay (sec/veh)		
		Demand	Served	% Served		Average	Std. Dev.	LOS
NB	Left Turn	20	20	101.5%	0.1	58.8	35.4	F
	Through	10	8	84.0%	0.5	43.3	17.3	E
	Right Turn	10	8	84.0%	0.5	32.6	28.9	D
	Subtotal	40	37	92.8%	0.5	49.0	25.7	E
SB	Left Turn							
	Through							
	Right Turn							
	Subtotal							
EB	Left Turn	20	17	87.0%	0.6	32.9	12.2	D
	Through	110	113	103.1%	0.3	20.3	6.5	C
	Right Turn	10	11	110.0%	0.3	24.3	38.5	C
	Subtotal	140	142	101.3%	0.2	21.7	7.8	C
WB	Left Turn							
	Through	210	167	79.6%	3.1	21.5	2.2	C
	Right Turn	60	47	79.0%	1.7	6.3	3.0	A
	Subtotal	270	215	79.4%	3.6	18.2	1.8	C
Total		450	393	87.4%	2.8	22.3	4.4	C

Intersection

Railroad Avenue/9th Avenue

Unsignalized

Direction	Movement	Volume (veh/hr)			GEH	Total Delay (sec/veh)		
		Demand	Served	% Served		Average	Std. Dev.	LOS
NB	Left Turn	30	30	100.3%	0.0	199.3	176.4	F
	Through							
	Right Turn	20	19	93.5%	0.3	134.3	100.9	F
	Subtotal	50	49	97.6%	0.2	176.9	151.8	F
SB	Left Turn							
	Through							
	Right Turn							
	Subtotal							
EB	Left Turn							
	Through	580	578	99.6%	0.1	1.6	0.2	A
	Right Turn	120	125	104.0%	0.4	0.4	0.1	A
	Subtotal	700	702	100.3%	0.1	1.4	0.1	A
WB	Left Turn	10	10	96.0%	0.1	19.9	11.0	C
	Through	600	607	101.2%	0.3	9.1	1.6	A
	Right Turn							
	Subtotal	610	617	101.1%	0.3	9.3	1.7	A
Total		1360	1368	100.6%	0.2	11.4	6.9	B

Intersection

S B Street/9th Avenue

Signalized

Direction	Movement	Volume (veh/hr)			GEH	Total Delay (sec/veh)		
		Demand	Served	% Served		Average	Std. Dev.	LOS
NB	Left Turn	10	9	86.0%	0.5	43.6	18.0	D
	Through	120	127	105.6%	0.6	33.9	10.4	C
	Right Turn	160	164	102.5%	0.3	28.3	13.0	C
	Subtotal	290	299	103.2%	0.5	31.1	11.8	C
SB	Left Turn	80	74	92.1%	0.7	76.0	21.6	E
	Through	80	88	110.5%	0.9	29.7	9.8	C
	Right Turn	50	50	99.2%	0.1	21.9	11.4	C
	Subtotal	210	212	100.8%	0.1	43.9	13.8	D
EB	Left Turn	40	38	93.8%	0.4	68.8	17.7	E
	Through	460	459	99.7%	0.1	58.9	19.3	E
	Right Turn	10	10	98.0%	0.1	46.9	21.3	D
	Subtotal	510	506	99.2%	0.2	59.4	19.1	E
WB	Left Turn	110	107	97.5%	0.3	26.0	4.5	C
	Through	420	427	101.6%	0.3	10.3	1.0	B
	Right Turn	100	101	100.8%	0.1	6.8	1.3	A
	Subtotal	630	635	100.8%	0.2	12.4	1.5	B
Total		1640	1652	100.7%	0.3	34.3	5.2	C

Intersection

Concar Drive/SR 92 WB Ramps

Signalized

Direction	Movement	Volume (veh/hr)			GEH	Total Delay (sec/veh)		
		Demand	Served	% Served		Average	Std. Dev.	LOS
NB	Left Turn	270	240	88.8%	1.9	45.1	3.0	D
	Through	70	65	92.1%	0.7	41.8	3.7	D
	Right Turn							
	Subtotal	340	304	89.5%	2.0	44.4	3.0	D
SB	Left Turn	10	11	111.0%	0.3	12.6	3.1	B
	Through	10	11	110.0%	0.3	11.1	4.4	B
	Right Turn	10	11	109.0%	0.3	3.8	1.8	A
	Subtotal	30	33	110.0%	0.5	9.4	1.8	A
EB	Left Turn	10	9	87.0%	0.4	74.4	38.1	E
	Through	70	75	107.1%	0.6	72.5	34.1	E
	Right Turn	50	53	105.2%	0.4	52.7	33.7	D
	Subtotal	130	136	104.8%	0.5	64.8	34.2	E
WB	Left Turn	1020	1010	99.0%	0.3	8.8	0.4	A
	Through	30	33	110.0%	0.5	8.8	2.1	A
	Right Turn	20	19	92.5%	0.3	2.2	1.0	A
	Subtotal	1070	1061	99.2%	0.3	8.7	0.4	A
Total		1570	1535	97.8%	0.9	20.8	3.4	C

SimTraffic Post-Processor
Average Results from 20 Runs
Volume and Delay by Movement

Caltrain Electrification
2040 No Project Conditions
AM Peak Hour

Intersection Delaware Ave/25th Ave

Signalized

Direction	Movement	Volume (veh/hr)			GEH	Total Delay (sec/veh)		
		Demand	Served	% Served		Average	Std. Dev.	LOS
NB	Left Turn	30	24	79.3%	1.2	262.5	262.2	F
	Through	20	19	94.0%	0.3	15.4	4.3	B
	Right Turn							
	Subtotal	50	43	85.2%	1.1	150.8	141.1	F
SB	Left Turn							
	Through	40	39	98.5%	0.1	18.3	7.2	B
	Right Turn	730	702	96.2%	1.0	68.1	48.2	E
	Subtotal	770	742	96.3%	1.0	65.6	46.4	E
EB	Left Turn	720	535	74.3%	7.4	36.6	2.3	D
	Through							
	Right Turn	60	42	70.5%	2.5	14.9	2.6	B
	Subtotal	780	577	74.0%	7.8	35.0	2.3	C
WB	Left Turn							
	Through							
	Right Turn							
	Subtotal							
Total		1600	1361	85.1%	6.2	55.7	27.4	E

Intersection El Camino Real/25th Ave

Signalized

Direction	Movement	Volume (veh/hr)			GEH	Total Delay (sec/veh)		
		Demand	Served	% Served		Average	Std. Dev.	LOS
NB	Left Turn	70	69	98.0%	0.2	84.5	12.1	F
	Through	1690	1668	98.7%	0.5	67.6	13.1	E
	Right Turn	330	315	95.5%	0.8	83.2	15.5	F
	Subtotal	2090	2052	98.2%	0.8	70.5	13.3	E
SB	Left Turn	130	125	96.1%	0.5	54.7	2.9	D
	Through	1560	1540	98.7%	0.5	27.2	1.2	C
	Right Turn	60	64	106.0%	0.5	30.7	2.5	C
	Subtotal	1750	1729	98.8%	0.5	29.3	1.3	C
EB	Left Turn	150	92	61.6%	5.2	628.6	54.3	F
	Through	170	105	61.7%	5.6	810.6	62.7	F
	Right Turn	40	23	57.8%	3.0	622.0	60.2	F
	Subtotal	360	220	61.2%	8.2	715.6	64.4	F
WB	Left Turn	880	655	74.5%	8.1	67.5	2.3	E
	Through	120	90	74.8%	3.0	72.9	3.2	E
	Right Turn	70	53	75.6%	2.2	40.1	7.6	D
	Subtotal	1070	798	74.6%	8.9	66.3	2.3	E
Total		5270	4799	91.1%	6.6	84.4	5.4	F

Intersection

El Camino Real/31st Street

Signalized

Direction	Movement	Volume (veh/hr)			GEH	Total Delay (sec/veh)		
		Demand	Served	% Served		Average	Std. Dev.	LOS
NB	Left Turn	80	73	91.1%	0.8	100.0	28.0	F
	Through	1810	1794	99.1%	0.4	29.4	1.6	C
	Right Turn	190	188	98.9%	0.1	11.2	1.4	B
	Subtotal	2080	2055	98.8%	0.5	30.3	2.5	C
SB	Left Turn	80	77	96.5%	0.3	77.8	13.5	E
	Through	2040	1981	97.1%	1.3	132.3	25.6	F
	Right Turn	120	119	99.4%	0.1	212.1	56.6	F
	Subtotal	2240	2177	97.2%	1.3	134.8	26.4	F
EB	Left Turn	320	322	100.6%	0.1	75.0	14.3	E
	Through	70	70	99.6%	0.0	85.9	19.7	F
	Right Turn	260	263	101.1%	0.2	19.4	2.6	B
	Subtotal	650	654	100.7%	0.2	53.9	9.6	D
WB	Left Turn	30	29	97.3%	0.1	31.1	6.5	C
	Through	90	91	100.9%	0.1	31.3	3.3	C
	Right Turn	90	95	105.2%	0.5	17.7	2.8	B
	Subtotal	210	215	102.2%	0.3	25.3	3.2	C
Total		5180	5101	98.5%	1.1	77.7	10.8	E

Intersection

El Camino Real/Hillsdale Blvd

Signalized

Direction	Movement	Volume (veh/hr)			GEH	Total Delay (sec/veh)		
		Demand	Served	% Served		Average	Std. Dev.	LOS
NB	Left Turn							
	Through							
	Right Turn							
	Subtotal							
SB	Left Turn	900	873	97.0%	0.9	65.1	9.0	E
	Through							
	Right Turn	260	249	95.6%	0.7	18.0	2.2	B
	Subtotal	1160	1122	96.7%	1.1	54.7	7.7	D
EB	Left Turn							
	Through	860	673	78.2%	6.8	104.3	1.0	F
	Right Turn	130	99	76.1%	2.9	56.0	5.7	E
	Subtotal	990	772	77.9%	7.4	98.1	1.7	F
WB	Left Turn	380	355	93.4%	1.3	2.5	0.5	A
	Through	880	845	96.0%	1.2	2.8	0.2	A
	Right Turn							
	Subtotal	1260	1200	95.2%	1.7	2.7	0.2	A
Total		3410	3093	90.7%	5.6	122.6	2.8	F

SimTraffic Post-Processor
Average Results from 20 Runs
Volume and Delay by Movement

Caltrain Electrification
2040 No Project Conditions
AM Peak Hour

Intersection

Curtiss Street/Hillsdale Blvd

Signalized

Direction	Movement	Volume (veh/hr)			GEH	Total Delay (sec/veh)		
		Demand	Served	% Served		Average	Std. Dev.	LOS
NB	Left Turn	120	118	98.3%	0.2	110.0	55.7	F
	Through	10	9	90.0%	0.3	95.2	40.0	F
	Right Turn	190	179	94.2%	0.8	71.2	58.2	E
	Subtotal	320	306	95.6%	0.8	86.7	56.9	F
SB	Left Turn	40	39	97.5%	0.2	49.0	9.3	D
	Through	10	10	99.0%	0.0	46.7	16.8	D
	Right Turn	40	43	106.3%	0.4	56.7	14.6	E
	Subtotal	90	91	101.6%	0.1	52.2	11.9	D
EB	Left Turn	10	9	85.0%	0.5	49.8	21.0	D
	Through	1140	1046	91.8%	2.8	13.8	2.4	B
	Right Turn	190	172	90.3%	1.4	12.4	2.0	B
	Subtotal	1340	1226	91.5%	3.2	13.8	2.5	B
WB	Left Turn	30	27	89.3%	0.6	87.9	12.4	F
	Through	1260	1190	94.5%	2.0	88.4	16.6	F
	Right Turn	30	31	103.7%	0.2	113.7	34.2	F
	Subtotal	1320	1248	94.6%	2.0	89.1	16.7	F
Total		3070	2871	93.5%	3.6	55.6	10.0	E

SimTraffic Post-Processor
Average Results from 20 Runs
Volume and Delay by Movement

Caltrain Electrification
2040 No Project Conditions
AM Peak Hour

Intersection

El Camino Real/Ralston Avenue

Signalized

Direction	Movement	Volume (veh/hr)			GEH	Total Delay (sec/veh)		
		Demand	Served	% Served		Average	Std. Dev.	LOS
NB	Left Turn	110	92	83.5%	1.8	277.0	35.5	F
	Through	940	816	86.8%	4.2	229.3	12.7	F
	Right Turn	200	176	88.2%	1.7	29.5	3.3	C
	Subtotal	1250	1084	86.7%	4.9	201.0	12.0	F
SB	Left Turn	340	258	75.9%	4.7	375.6	37.7	F
	Through	1050	907	86.4%	4.6	81.0	8.1	F
	Right Turn	120	94	78.7%	2.5	33.3	6.6	C
	Subtotal	1510	1260	83.4%	6.7	138.2	10.9	F
EB	Left Turn	210	179	85.0%	2.3	301.5	68.5	F
	Through	780	667	85.6%	4.2	339.1	70.6	F
	Right Turn	140	122	86.9%	1.6	368.7	71.7	F
	Subtotal	1130	968	85.6%	5.0	336.0	70.1	F
WB	Left Turn	160	159	99.6%	0.0	39.2	1.8	D
	Through	600	602	100.4%	0.1	51.9	3.8	D
	Right Turn	190	195	102.6%	0.4	13.8	1.8	B
	Subtotal	950	957	100.7%	0.2	42.0	2.5	D
Total		4840	4268	88.2%	8.5	177.3	14.9	F

Intersection

El Camino Real/San Carlos Avenue-Caltrain Station

Signalized

Direction	Movement	Volume (veh/hr)			GEH	Total Delay (sec/veh)		
		Demand	Served	% Served		Average	Std. Dev.	LOS
NB	Left Turn	90	88	97.8%	0.2	48.8	5.7	D
	Through	680	696	102.3%	0.6	19.0	1.3	B
	Right Turn	10	12	119.0%	0.6	18.0	7.9	B
	Subtotal	780	796	102.0%	0.6	22.3	1.4	C
SB	Left Turn	20	17	86.0%	0.6	46.1	8.6	D
	Through	870	893	102.6%	0.8	24.3	2.3	C
	Right Turn	360	362	100.5%	0.1	10.9	1.6	B
	Subtotal	1250	1272	101.8%	0.6	20.8	2.1	C
EB	Left Turn	500	496	99.1%	0.2	11.6	2.7	B
	Through	40	47	116.3%	1.0	15.6	5.3	B
	Right Turn	240	246	102.5%	0.4	16.8	2.8	B
	Subtotal	780	788	101.1%	0.3	13.5	2.6	B
WB	Left Turn	40	38	94.3%	0.4	55.0	5.4	D
	Through	40	44	109.0%	0.6	46.1	7.7	D
	Right Turn	40	37	92.8%	0.5	19.9	3.8	B
	Subtotal	120	118	98.7%	0.1	40.4	4.3	D
Total		2930	2974	101.5%	0.8	20.0	0.9	B

Intersection

California/Broadway

Unsignalized

Direction	Movement	Volume (veh/hr)			GEH	Total Delay (sec/veh)		
		Demand	Served	% Served		Average	Std. Dev.	LOS
NB	Left Turn	40	4	10.8%	7.6	2711.4	948.3	F
	Through	60	6	9.8%	9.4	2782.3	541.1	F
	Right Turn	190	21	11.1%	16.5	2589.0	423.9	F
	Subtotal	290	31	10.8%	20.4	2633.7	346.1	F
SB	Left Turn	90	3	2.8%	12.9	7632.9	5195.6	F
	Through	50	3	5.6%	9.2	3573.6	2915.9	F
	Right Turn	20	0	1.5%	6.2	813.0	881.6	F
	Subtotal	160	6	3.5%	17.0	5562.0	2969.2	F
EB	Left Turn	30	6	21.3%	5.5	268.9	126.8	F
	Through	1000	225	22.5%	31.3	147.5	16.5	F
	Right Turn	180	36	20.1%	13.8	142.8	18.9	F
	Subtotal	1210	268	22.1%	34.7	149.6	17.0	F
WB	Left Turn	160	60	37.2%	9.6	39.9	6.1	E
	Through	940	330	35.1%	24.2	32.6	3.4	D
	Right Turn	120	41	34.5%	8.7	4.3	2.5	A
	Subtotal	1220	430	35.3%	27.5	30.8	3.2	D
Total		2880	735	25.5%	50.5	215.1	13.6	F

Intersection

Arguello Street/Brewster Ave

Signalized

Direction	Movement	Volume (veh/hr)			GEH	Total Delay (sec/veh)		
		Demand	Served	% Served		Average	Std. Dev.	LOS
NB	Left Turn	90	23	25.1%	9.0	21.4	4.2	C
	Through	300	79	26.2%	16.1	24.1	3.5	C
	Right Turn	90	25	27.6%	8.6	4.8	0.7	A
	Subtotal	480	126	26.3%	20.3	19.9	2.7	B
SB	Left Turn	40	14	35.8%	4.9	561.4	155.2	F
	Through	390	129	33.2%	16.2	614.2	125.4	F
	Right Turn	150	51	33.7%	9.9	610.1	138.4	F
	Subtotal	580	194	33.5%	19.6	609.3	127.2	F
EB	Left Turn	90	41	45.9%	6.0	29.9	5.1	C
	Through	500	206	41.1%	15.7	19.7	1.3	B
	Right Turn	150	64	42.3%	8.4	43.5	11.1	D
	Subtotal	740	311	42.0%	18.7	26.0	2.7	C
WB	Left Turn	120	114	94.9%	0.6	157.4	53.7	F
	Through	140	131	93.4%	0.8	63.7	19.7	E
	Right Turn	20	19	95.0%	0.2	53.3	46.3	D
	Subtotal	280	264	94.2%	1.0	102.5	30.8	F
Total		2080	895	43.0%	30.7	170.8	18.8	F

Intersection

El Camino Real/Broadway

Signalized

Direction	Movement	Volume (veh/hr)			GEH	Total Delay (sec/veh)		
		Demand	Served	% Served		Average	Std. Dev.	LOS
NB	Left Turn	170	118	69.5%	4.3	183.0	9.8	F
	Through	1140	839	73.6%	9.6	152.1	4.6	F
	Right Turn	80	57	71.5%	2.8	150.1	28.6	F
	Subtotal	1390	1015	73.0%	10.8	155.6	4.9	F
SB	Left Turn	230	122	53.1%	8.1	447.1	56.3	F
	Through	1050	622	59.2%	14.8	53.9	7.2	D
	Right Turn	10	7	74.0%	0.9	28.1	10.9	C
	Subtotal	1290	751	58.2%	16.9	117.9	8.3	F
EB	Left Turn	10	2	17.0%	3.4	704.8	551.7	F
	Through	900	92	10.2%	36.3	869.8	138.9	F
	Right Turn	290	27	9.2%	20.9	731.7	118.9	F
	Subtotal	1200	120	10.0%	42.0	837.2	133.4	F
WB	Left Turn	30	9	30.3%	4.7	105.0	19.5	F
	Through	570	185	32.4%	19.8	118.3	10.5	F
	Right Turn	400	136	34.1%	16.1	110.1	8.0	F
	Subtotal	1000	330	33.0%	26.0	114.7	9.3	F
Total		4880	2216	45.4%	44.7	172.7	7.2	F

Intersection

Arguello St/Broadway

Signalized

Direction	Movement	Volume (veh/hr)			GEH	Total Delay (sec/veh)		
		Demand	Served	% Served		Average	Std. Dev.	LOS
NB	Left Turn	270	55	20.4%	16.9	618.9	99.9	F
	Through	200	41	20.5%	14.5	596.0	99.0	F
	Right Turn	50	11	22.0%	7.1	561.5	142.9	F
	Subtotal	520	107	20.6%	23.3	605.2	99.6	F
SB	Left Turn	160	77	48.1%	7.6	318.9	38.7	F
	Through	300	138	46.0%	10.9	317.8	38.6	F
	Right Turn	200	96	47.9%	8.6	332.0	45.3	F
	Subtotal	660	311	47.1%	15.9	322.6	37.2	F
EB	Left Turn	110	23	20.5%	10.7	26.9	4.1	C
	Through	870	170	19.5%	30.7	15.4	1.7	B
	Right Turn	300	58	19.3%	18.1	2.9	0.9	A
	Subtotal	1280	250	19.5%	37.2	13.5	1.3	B
WB	Left Turn	30	11	37.7%	4.1	197.5	29.4	F
	Through	750	283	37.8%	20.5	204.2	17.5	F
	Right Turn	170	59	34.9%	10.3	143.5	24.6	F
	Subtotal	950	354	37.2%	23.4	193.8	16.7	F
Total		3410	1022	30.0%	50.7	230.1	13.0	F

SimTraffic Post-Processor
Average Results from 20 Runs
Volume and Delay by Movement

Caltrain Electrification
2040 No Project Conditions
AM Peak Hour

Intersection

El Camino Real/James

Signalized

Direction	Movement	Volume (veh/hr)			GEH	Total Delay (sec/veh)		
		Demand	Served	% Served		Average	Std. Dev.	LOS
NB	Left Turn	179	118	65.9%	5.0	278.5	12.6	F
	Through	1263	856	67.8%	12.5	296.0	14.4	F
	Right Turn	95	67	70.9%	3.1	177.0	11.1	F
	Subtotal	1537	1042	67.8%	13.8	286.3	13.6	F
SB	Left Turn	116	50	43.0%	7.3	58.4	9.9	E
	Through	1211	545	45.0%	22.5	21.5	2.7	C
	Right Turn	116	58	49.7%	6.3	10.0	1.8	A
	Subtotal	1443	653	45.2%	24.4	23.3	2.8	C
EB	Left Turn	147	145	98.3%	0.2	96.9	30.8	F
	Through	95	87	92.0%	0.8	25.6	10.6	C
	Right Turn	179	183	102.2%	0.3	17.6	11.4	B
	Subtotal	421	415	98.6%	0.3	47.0	17.9	D
WB	Left Turn	74	18	24.6%	8.2	24.9	3.5	C
	Through	284	73	25.5%	15.8	20.7	4.0	C
	Right Turn	53	14	25.5%	6.9	34.3	8.8	C
	Subtotal	411	104	25.4%	19.1	23.3	3.6	C
Total		3812	2213	58.1%	29.1	151.6	8.3	F

SimTraffic Post-Processor
Average Results from 20 Runs
Volume and Delay by Movement

Caltrain Electrification
2040 No Project Conditions
AM Peak Hour

Intersection

El Camino Real/Atherton Avenue-Fair Oaks Lane

Signalized

Direction	Movement	Volume (veh/hr)			GEH	Total Delay (sec/veh)		
		Demand	Served	% Served		Average	Std. Dev.	LOS
NB	Left Turn	140	112	79.6%	2.5	416.6	217.7	F
	Through	1590	1555	97.8%	0.9	58.3	19.4	E
	Right Turn	30	27	90.3%	0.5	64.9	17.5	E
	Subtotal	1760	1693	96.2%	1.6	82.1	32.3	F
SB	Left Turn	160	131	82.1%	2.4	414.0	73.6	F
	Through	1810	1573	86.9%	5.8	350.2	68.5	F
	Right Turn	180	161	89.3%	1.5	381.0	71.1	F
	Subtotal	2150	1865	86.8%	6.4	357.3	67.4	F
EB	Left Turn	120	112	93.6%	0.7	61.1	16.5	E
	Through	140	139	99.1%	0.1	58.6	16.1	E
	Right Turn	180	184	102.4%	0.3	46.3	16.0	D
	Subtotal	440	435	99.0%	0.2	54.0	15.9	D
WB	Left Turn	100	101	100.5%	0.0	107.8	46.8	F
	Through	130	129	98.8%	0.1	103.5	44.8	F
	Right Turn	70	69	98.9%	0.1	75.3	45.7	E
	Subtotal	300	298	99.4%	0.1	98.5	46.0	F
Total		4650	4292	92.3%	5.4	199.9	30.5	F

Intersection

El Camino Real/Watkins Avenue

Unsignalized

Direction	Movement	Volume (veh/hr)			GEH	Total Delay (sec/veh)		
		Demand	Served	% Served		Average	Std. Dev.	LOS
NB	Left Turn							
	Through	1680	1687	100.4%	0.2	2.2	1.2	A
	Right Turn	70	71	102.0%	0.2	2.9	0.7	A
	Subtotal	1750	1758	100.5%	0.2	2.2	1.2	A
SB	Left Turn	70	64	90.9%	0.8	29.4	7.1	D
	Through	2020	1813	89.7%	4.7	5.3	0.1	A
	Right Turn							
	Subtotal	2090	1877	89.8%	4.8	6.1	0.3	A
EB	Left Turn							
	Through							
	Right Turn							
	Subtotal							
WB	Left Turn	120	40	33.0%	9.0	1858.9	478.3	F
	Through							
	Right Turn	80	28	35.1%	7.1	1862.5	573.1	F
	Subtotal	200	68	33.9%	11.4	1859.3	503.5	F
Total		4040	3702	91.6%	5.4	36.6	2.2	E

Intersection

El Camino Real/Glenwood

Signalized

Direction	Movement	Volume (veh/hr)			GEH	Total Delay (sec/veh)		
		Demand	Served	% Served		Average	Std. Dev.	LOS
NB	Left Turn	70	68	97.0%	0.3	65.6	8.7	E
	Through	930	922	99.1%	0.3	24.0	0.8	C
	Right Turn	40	43	107.3%	0.5	16.2	2.0	B
	Subtotal	1040	1032	99.3%	0.2	26.4	0.9	C
SB	Left Turn	100	79	79.4%	2.2	169.1	23.3	F
	Through	1500	1190	79.3%	8.5	169.2	21.6	F
	Right Turn	470	374	79.5%	4.7	60.1	9.1	E
	Subtotal	2070	1643	79.4%	9.9	144.4	18.4	F
EB	Left Turn	260	256	98.6%	0.2	79.3	27.9	E
	Through	150	147	97.9%	0.3	82.3	27.8	F
	Right Turn	100	102	101.5%	0.1	60.9	20.7	E
	Subtotal	510	505	98.9%	0.2	76.6	25.8	E
WB	Left Turn	90	84	93.8%	0.6	92.2	40.6	F
	Through	190	188	99.2%	0.1	73.4	33.5	E
	Right Turn	20	21	105.5%	0.2	57.1	26.0	E
	Subtotal	300	294	98.0%	0.4	77.7	34.6	E
Total		3920	3473	88.6%	7.3	93.9	9.9	F

Intersection

El Camino Real/Oak Grove

Signalized

Direction	Movement	Volume (veh/hr)			GEH	Total Delay (sec/veh)		
		Demand	Served	% Served		Average	Std. Dev.	LOS
NB	Left Turn	110	112	102.2%	0.2	64.9	13.5	E
	Through	800	798	99.7%	0.1	28.4	1.5	C
	Right Turn	80	77	96.3%	0.3	12.0	2.3	B
	Subtotal	990	987	99.7%	0.1	31.3	2.3	C
SB	Left Turn	270	218	80.7%	3.3	134.4	7.0	F
	Through	1340	1081	80.7%	7.4	131.2	11.1	F
	Right Turn	80	65	81.8%	1.7	115.5	12.1	F
	Subtotal	1690	1365	80.8%	8.3	131.0	10.1	F
EB	Left Turn	70	72	102.4%	0.2	57.8	8.2	E
	Through	150	151	100.3%	0.0	37.6	3.4	D
	Right Turn	60	61	101.8%	0.1	50.1	15.9	D
	Subtotal	280	283	101.2%	0.2	45.4	5.2	D
WB	Left Turn	210	197	93.7%	0.9	103.3	10.9	F
	Through	250	232	92.6%	1.2	61.1	6.6	E
	Right Turn	170	163	96.1%	0.5	33.7	4.3	C
	Subtotal	630	592	93.9%	1.5	67.6	7.0	E
Total		3590	3227	89.9%	6.2	81.3	4.0	F

Intersection

El Camino Real/Santa Cruz Ave

Signalized

Direction	Movement	Volume (veh/hr)			GEH	Total Delay (sec/veh)		
		Demand	Served	% Served		Average	Std. Dev.	LOS
NB	Left Turn							
	Through	860	873	101.5%	0.4	18.0	0.8	B
	Right Turn	50	50	99.0%	0.1	12.2	2.2	B
	Subtotal	910	922	101.4%	0.4	17.7	0.8	B
SB	Left Turn							
	Through	1410	1176	83.4%	6.5	51.0	2.4	D
	Right Turn	200	168	83.9%	2.4	31.5	2.1	C
	Subtotal	1610	1344	83.4%	6.9	48.6	2.4	D
EB	Left Turn	100	97	96.9%	0.3	74.0	38.4	E
	Through	270	262	97.0%	0.5	85.4	44.9	F
	Right Turn	180	181	100.7%	0.1	111.6	43.8	F
	Subtotal	550	540	98.2%	0.4	92.2	43.2	F
WB	Left Turn	110	101	91.4%	0.9	67.2	9.0	E
	Through	70	70	99.3%	0.1	32.3	4.6	C
	Right Turn	30	31	102.7%	0.1	16.9	5.7	B
	Subtotal	210	201	95.6%	0.6	47.3	4.9	D
Total		3280	3007	91.7%	4.9	46.9	8.5	D

Intersection

Merril St/Santa Cruz Ave

Unsignalized

Direction	Movement	Volume (veh/hr)			GEH	Total Delay (sec/veh)		
		Demand	Served	% Served		Average	Std. Dev.	LOS
NB	Left Turn	75	73	97.3%	0.2	9.6	2.6	A
	Through	80	82	102.6%	0.2	9.4	2.4	A
	Right Turn	215	206	95.9%	0.6	7.4	1.9	A
	Subtotal	370	361	97.6%	0.5	8.3	1.9	A
SB	Left Turn	20	17	84.5%	0.7	11.4	7.2	B
	Through	30	30	98.3%	0.1	9.7	2.2	A
	Right Turn	75	65	86.8%	1.2	9.0	5.8	A
	Subtotal	125	112	89.2%	1.2	9.5	4.9	A
EB	Left Turn	90	84	93.7%	0.6	15.3	1.9	C
	Through	60	65	107.7%	0.6	15.3	2.1	C
	Right Turn	170	169	99.3%	0.1	13.8	1.4	B
	Subtotal	320	318	99.3%	0.1	14.5	1.5	B
WB	Left Turn	10	8	82.0%	0.6	8.7	6.9	A
	Through	60	60	100.2%	0.0	10.6	4.8	B
	Right Turn	30	31	102.0%	0.1	6.0	2.3	A
	Subtotal	100	99	98.9%	0.1	9.0	3.8	A
Total		915	889	97.2%	0.9	10.7	2.1	B

SimTraffic Post-Processor
Average Results from 20 Runs
Volume and Delay by Movement

Caltrain Electrification
2040 No Project Conditions
AM Peak Hour

Intersection

Ravenswood Ave/Laurel St

Signalized

Direction	Movement	Volume (veh/hr)			GEH	Total Delay (sec/veh)		
		Demand	Served	% Served		Average	Std. Dev.	LOS
NB	Left Turn	179	170	95.1%	0.7	28.8	3.3	C
	Through	74	67	90.0%	0.9	21.8	3.7	C
	Right Turn	32	27	83.1%	1.0	20.7	3.7	C
	Subtotal	285	264	92.5%	1.3	26.2	2.7	C
SB	Left Turn	432	304	70.5%	6.6	188.4	9.1	F
	Through	179	121	67.8%	4.7	187.4	6.0	F
	Right Turn	84	64	76.0%	2.3	182.4	11.8	F
	Subtotal	695	490	70.4%	8.4	187.4	8.4	F
EB	Left Turn	42	32	76.0%	1.7	91.8	30.4	F
	Through	832	679	81.6%	5.6	44.0	3.0	D
	Right Turn	116	96	82.9%	1.9	40.0	5.1	D
	Subtotal	990	807	81.5%	6.1	45.4	3.5	D
WB	Left Turn	21	17	82.9%	0.8	137.0	41.9	F
	Through	821	754	91.9%	2.4	92.9	43.6	F
	Right Turn	21	17	80.5%	0.9	83.4	46.8	F
	Subtotal	863	789	91.4%	2.6	93.7	43.4	F
Total		2833	2349	82.9%	9.5	89.2	15.6	F

Intersection

High Street/University Ave

Signalized

Direction	Movement	Volume (veh/hr)			GEH	Total Delay (sec/veh)		
		Demand	Served	% Served		Average	Std. Dev.	LOS
NB	Left Turn							
	Through							
	Right Turn							
	Subtotal							
SB	Left Turn	20	18	88.5%	0.5	19.3	4.3	B
	Through	30	34	112.0%	0.6	12.7	2.5	B
	Right Turn	220	220	100.1%	0.0	11.9	1.4	B
	Subtotal	270	272	100.6%	0.1	12.5	1.3	B
EB	Left Turn							
	Through	510	514	100.8%	0.2	11.5	0.8	B
	Right Turn	270	279	103.4%	0.6	3.6	0.3	A
	Subtotal	780	793	101.7%	0.5	8.7	0.5	A
WB	Left Turn	20	19	95.5%	0.2	21.7	6.4	C
	Through	540	537	99.5%	0.1	10.4	1.9	B
	Right Turn							
	Subtotal	560	556	99.4%	0.2	10.8	2.0	B
Total		1610	1621	100.7%	0.3	10.1	1.0	B

Intersection

Showers Drive/Pacchetti Way

Signalized

Direction	Movement	Volume (veh/hr)			GEH	Total Delay (sec/veh)		
		Demand	Served	% Served		Average	Std. Dev.	LOS
NB	Left Turn	20	19	93.5%	0.3	22.3	1.8	C
	Through	20	19	94.5%	0.2	1.9	1.4	A
	Right Turn							
	Subtotal	40	38	94.0%	0.4	12.0	2.3	B
SB	Left Turn							
	Through	80	87	108.3%	0.7	3.2	0.7	A
	Right Turn	30	31	102.7%	0.1	1.2	0.4	A
	Subtotal	110	117	106.7%	0.7	2.7	0.5	A
EB	Left Turn	10	9	92.0%	0.3	12.5	1.4	B
	Through							
	Right Turn	10	11	112.0%	0.4	3.3	1.2	A
	Subtotal	20	20	102.0%	0.1	7.5	1.3	A
WB	Left Turn							
	Through							
	Right Turn							
	Subtotal							
Total		170	175	103.2%	0.4	5.2	0.7	A

Intersection Hope Street/Evelyn Ave

Signalized

Direction	Movement	Volume (veh/hr)			GEH	Total Delay (sec/veh)		
		Demand	Served	% Served		Average	Std. Dev.	LOS
NB	Left Turn	20	19	96.0%	0.2	26.9	4.4	C
	Through							
	Right Turn	70	74	105.0%	0.4	6.2	1.1	A
	Subtotal	90	93	103.0%	0.3	10.6	2.4	B
SB	Left Turn							
	Through							
	Right Turn							
	Subtotal							
EB	Left Turn							
	Through	70	67	95.0%	0.4	1.3	0.4	A
	Right Turn	20	22	108.0%	0.4	0.4	0.2	A
	Subtotal	90	88	97.9%	0.2	1.1	0.3	A
WB	Left Turn	50	53	105.0%	0.3	1.5	0.8	A
	Through	650	659	101.4%	0.4	2.1	0.2	A
	Right Turn							
	Subtotal	700	712	101.7%	0.4	2.0	0.2	A
Total		880	893	101.4%	0.4	2.8	0.3	A

Intersection Castro Street/Villa Street

Signalized

Direction	Movement	Volume (veh/hr)			GEH	Total Delay (sec/veh)		
		Demand	Served	% Served		Average	Std. Dev.	LOS
NB	Left Turn	20	20	99.0%	0.0	77.2	11.6	E
	Through	220	218	99.1%	0.1	29.6	2.7	C
	Right Turn	80	81	100.8%	0.1	21.6	3.7	C
	Subtotal	320	318	99.5%	0.1	30.6	3.2	C
SB	Left Turn	170	170	100.2%	0.0	30.4	4.3	C
	Through	200	207	103.5%	0.5	27.5	3.1	C
	Right Turn	350	348	99.4%	0.1	21.3	3.2	C
	Subtotal	720	725	100.7%	0.2	25.2	3.0	C
EB	Left Turn	210	212	100.9%	0.1	89.8	21.4	F
	Through	230	230	99.9%	0.0	89.8	18.4	F
	Right Turn	10	10	100.0%	0.0	74.2	27.5	E
	Subtotal	450	452	100.3%	0.1	89.6	19.7	F
WB	Left Turn	50	46	92.4%	0.5	27.0	2.5	C
	Through	180	181	100.4%	0.1	23.0	1.6	C
	Right Turn	90	91	100.7%	0.1	17.6	1.7	B
	Subtotal	320	318	99.3%	0.1	22.0	1.5	C
Total		1810	1813	100.2%	0.1	41.6	5.1	D

SimTraffic Post-Processor
Average Results from 20 Runs
Volume and Delay by Movement

Caltrain Electrification
2040 No Project Conditions
AM Peak Hour

Intersection

Frances St/Evelyn Ave

Signalized

Direction	Movement	Volume (veh/hr)			GEH	Total Delay (sec/veh)		
		Demand	Served	% Served		Average	Std. Dev.	LOS
NB	Left Turn	40	40	100.0%	0.0	32.3	4.9	C
	Through	20	21	104.5%	0.2	26.4	5.5	C
	Right Turn	10	11	105.0%	0.2	17.4	10.4	B
	Subtotal	70	71	102.0%	0.2	28.4	4.8	C
SB	Left Turn	150	150	100.1%	0.0	64.4	23.2	E
	Through	30	32	105.3%	0.3	63.9	22.9	E
	Right Turn	120	122	101.8%	0.2	60.1	23.5	E
	Subtotal	300	304	101.3%	0.2	62.7	23.2	E
EB	Left Turn	50	45	89.8%	0.7	74.7	12.3	E
	Through	250	251	100.3%	0.1	12.8	0.4	B
	Right Turn	30	31	104.0%	0.2	7.7	2.0	A
	Subtotal	330	327	99.1%	0.2	20.8	1.9	C
WB	Left Turn	40	37	93.5%	0.4	75.8	26.9	E
	Through	800	805	100.6%	0.2	52.2	9.9	D
	Right Turn	150	149	99.2%	0.1	51.4	26.9	D
	Subtotal	990	991	100.1%	0.0	53.1	11.8	D
Total		1690	1693	100.2%	0.1	47.5	8.2	D

Intersection Lawrence Expressway/Kifer Road

Signalized

Direction	Movement	Volume (veh/hr)			GEH	Total Delay (sec/veh)		
		Demand	Served	% Served		Average	Std. Dev.	LOS
NB	Left Turn	610	408	66.8%	9.0	187.1	5.0	F
	Through	4640	3064	66.0%	25.4	200.0	4.6	F
	Right Turn	970	632	65.2%	11.9	235.7	5.4	F
	Subtotal	6220	4104	66.0%	29.5	204.2	3.7	F
SB	Left Turn	230	206	89.3%	1.7	470.5	152.7	F
	Through	1500	1478	98.5%	0.6	54.6	5.5	D
	Right Turn	400	408	102.0%	0.4	46.7	5.0	D
	Subtotal	2130	2091	98.2%	0.8	93.9	18.1	F
EB	Left Turn	160	162	101.4%	0.2	129.8	32.0	F
	Through	360	352	97.9%	0.4	76.3	3.1	E
	Right Turn	230	227	98.6%	0.2	2.0	0.2	A
	Subtotal	750	741	98.8%	0.3	65.7	8.7	E
WB	Left Turn	240	245	102.1%	0.3	71.9	3.7	E
	Through	460	463	100.7%	0.1	78.8	9.6	E
	Right Turn	700	685	97.9%	0.6	85.2	27.2	F
	Subtotal	1400	1394	99.6%	0.2	80.7	17.1	F
Total		10500	8330	79.3%	22.4	143.5	6.2	F

Intersection Lawrence Expressway/Reed Ave-Monroe St

Signalized

Direction	Movement	Volume (veh/hr)			GEH	Total Delay (sec/veh)		
		Demand	Served	% Served		Average	Std. Dev.	LOS
NB	Left Turn	220	150	68.1%	5.2	187.2	6.1	F
	Through	5370	3542	66.0%	27.4	113.8	4.2	F
	Right Turn	150	98	65.2%	4.7	92.4	6.9	F
	Subtotal	5740	3790	66.0%	28.3	116.1	4.1	F
SB	Left Turn	110	103	93.5%	0.7	57.6	10.2	E
	Through	1650	1644	99.7%	0.1	14.9	0.7	B
	Right Turn	210	210	99.8%	0.0	10.2	0.7	B
	Subtotal	1970	1957	99.3%	0.3	16.6	0.8	B
EB	Left Turn	490	402	81.9%	4.2	524.6	98.1	F
	Through	440	425	96.5%	0.7	91.9	12.7	F
	Right Turn	310	295	95.0%	0.9	19.3	8.2	B
	Subtotal	1240	1121	90.4%	3.5	227.8	39.4	F
WB	Left Turn	260	159	61.1%	7.0	369.9	96.9	F
	Through	320	201	62.7%	7.4	340.0	85.2	F
	Right Turn	360	169	47.0%	11.7	851.4	272.1	F
	Subtotal	940	529	56.3%	15.2	511.7	98.0	F
Total		9890	7396	74.8%	26.8	134.0	7.3	F

SimTraffic Post-Processor
Average Results from 20 Runs
Volume and Delay by Movement

Caltrain Electrification
2040 No Project Conditions
AM Peak Hour

Intersection

El Camino Real/Railroad Avenue

Signalized

Direction	Movement	Volume (veh/hr)			GEH	Total Delay (sec/veh)		
		Demand	Served	% Served		Average	Std. Dev.	LOS
NB	Left Turn	310	306	98.5%	0.3	40.7	3.4	D
	Through	1640	1608	98.0%	0.8	16.1	0.9	B
	Right Turn	70	70	99.6%	0.0	17.3	2.0	B
	Subtotal	2020	1983	98.2%	0.8	19.9	1.1	B
SB	Left Turn	80	71	89.1%	1.0	43.2	4.1	D
	Through	610	620	101.6%	0.4	19.3	1.3	B
	Right Turn	160	161	100.5%	0.1	19.7	2.7	B
	Subtotal	850	852	100.2%	0.1	21.4	1.6	C
EB	Left Turn	10	8	82.0%	0.6	34.1	6.5	C
	Through	10	10	99.0%	0.0	21.2	8.3	C
	Right Turn	30	29	95.7%	0.2	7.7	0.7	A
	Subtotal	50	47	93.6%	0.5	15.1	2.5	B
WB	Left Turn	70	69	98.9%	0.1	33.6	4.0	C
	Through	20	19	94.0%	0.3	19.6	4.3	B
	Right Turn	60	57	95.0%	0.4	11.6	1.4	B
	Subtotal	150	145	96.7%	0.4	23.2	1.8	C
Total		3070	3027	98.6%	0.8	20.4	0.7	C

Intersection Santa Clara Street/Cahill Street

Signalized

Direction	Movement	Volume (veh/hr)			GEH	Total Delay (sec/veh)		
		Demand	Served	% Served		Average	Std. Dev.	LOS
NB	Left Turn	380	368	96.9%	0.6	61.9	21.1	E
	Through	10	21	208.0%	2.8	31.2	14.2	C
	Right Turn	110	107	97.6%	0.2	34.6	18.2	C
	Subtotal	500	496	99.3%	0.2	54.8	20.3	D
SB	Left Turn	10	9	94.0%	0.2	56.0	11.4	E
	Through	10	9	85.0%	0.5	50.6	11.9	D
	Right Turn	10	11	109.0%	0.3	13.5	5.7	B
	Subtotal	30	29	96.0%	0.2	38.3	5.9	D
EB	Left Turn							
	Through	910	832	91.5%	2.6	143.8	15.7	F
	Right Turn	110	102	92.8%	0.8	153.0	14.8	F
	Subtotal	1020	934	91.6%	2.7	144.8	14.1	F
WB	Left Turn	490	374	76.2%	5.6	105.3	26.3	F
	Through	1060	821	77.5%	7.8	43.1	18.1	D
	Right Turn	20	14	69.0%	1.5	45.0	87.8	D
	Subtotal	1570	1209	77.0%	9.7	62.5	20.0	E
Total		3120	2668	85.5%	8.4	89.4	10.2	F

Intersection San Fernando Street/Montgomery Street

Signalized

Direction	Movement	Volume (veh/hr)			GEH	Total Delay (sec/veh)		
		Demand	Served	% Served		Average	Std. Dev.	LOS
NB	Left Turn							
	Through							
	Right Turn							
	Subtotal							
SB	Left Turn	70	56	80.0%	1.8	28.9	4.2	C
	Through	560	487	87.0%	3.2	52.5	12.3	D
	Right Turn	20	17	83.5%	0.8	52.4	21.3	D
	Subtotal	650	560	86.1%	3.7	50.0	11.5	D
EB	Left Turn							
	Through	230	197	85.5%	2.3	11.3	1.0	B
	Right Turn	190	167	88.0%	1.7	10.7	1.2	B
	Subtotal	420	364	86.6%	2.8	11.0	0.9	B
WB	Left Turn	140	143	101.9%	0.2	28.1	7.9	C
	Through	450	456	101.3%	0.3	25.2	6.6	C
	Right Turn							
	Subtotal	590	599	101.5%	0.4	25.9	6.8	C
Total		1660	1522	91.7%	3.5	31.3	6.6	C

Intersection

Lick Avenue-Shadow Run Drive/Alma Avenue

Signalized

Direction	Movement	Volume (veh/hr)			GEH	Total Delay (sec/veh)		
		Demand	Served	% Served		Average	Std. Dev.	LOS
NB	Left Turn	40	39	96.3%	0.2	60.9	6.5	E
	Through	30	32	106.3%	0.3	58.8	8.3	E
	Right Turn	20	20	97.5%	0.1	23.7	10.9	C
	Subtotal	90	90	99.9%	0.0	52.2	5.8	D
SB	Left Turn	70	71	101.3%	0.1	75.9	5.5	E
	Through	20	18	89.0%	0.5	55.3	12.4	E
	Right Turn	170	167	98.2%	0.2	19.8	8.7	B
	Subtotal	260	256	98.3%	0.3	37.9	7.3	D
EB	Left Turn	80	80	99.8%	0.0	65.6	9.9	E
	Through	730	750	102.7%	0.7	9.2	0.6	A
	Right Turn	50	46	92.6%	0.5	8.8	1.4	A
	Subtotal	860	876	101.9%	0.5	14.4	1.4	B
WB	Left Turn	10	10	96.0%	0.1	87.3	11.4	F
	Through	850	871	102.4%	0.7	22.3	1.3	C
	Right Turn	680	675	99.3%	0.2	31.4	2.7	C
	Subtotal	1540	1555	101.0%	0.4	26.6	1.7	C
Total		2750	2777	101.0%	0.5	24.6	1.1	C

SimTraffic Post-Processor
Average Results from 20 Runs
Volume and Delay by Movement

Caltrain Electrification
2040 No Project Conditions
AM Peak Hour

Intersection 7th Street/Mission Bay

Signalized

Direction	Movement	Volume (veh/hr)			GEH	Total Delay (sec/veh)		
		Demand	Served	% Served		Average	Std. Dev.	LOS
NB	Left Turn	10	9	91.0%	0.3	37.9	16.1	D
	Through	810	1069	132.0%	8.5	12.6	0.6	B
	Right Turn	50	69	138.6%	2.5	23.8	4.5	C
	Subtotal	870	1148	131.9%	8.7	13.4	0.7	B
SB	Left Turn	40	59	148.0%	2.7	56.8	8.2	E
	Through	290	390	134.4%	5.4	7.3	0.9	A
	Right Turn	10	11	105.0%	0.2	5.7	4.4	A
	Subtotal	340	460	135.2%	6.0	13.6	1.1	B
EB	Left Turn							
	Through							
	Right Turn							
	Subtotal							
WB	Left Turn	30	40	134.3%	1.7	3.2	2.1	A
	Through							
	Right Turn	70	102	145.3%	3.4	0.8	0.2	A
	Subtotal	100	142	142.0%	3.8	1.5	0.7	A
Total		1310	1749	133.5%	11.2	12.5	0.5	B

Intersection Berry Street/Mission Bay

Signalized

Direction	Movement	Volume (veh/hr)			GEH	Total Delay (sec/veh)		
		Demand	Served	% Served		Average	Std. Dev.	LOS
NB	Left Turn							
	Through							
	Right Turn							
	Subtotal							
SB	Left Turn							
	Through							
	Right Turn	140	142	101.7%	0.2	6.5	1.6	A
	Subtotal	140	142	101.7%	0.2	6.5	1.6	A
EB	Left Turn	130	128	98.2%	0.2	0.6	0.3	A
	Through							
	Right Turn							
	Subtotal	130	128	98.2%	0.2	0.6	0.3	A
WB	Left Turn							
	Through							
	Right Turn							
	Subtotal							
Total		270	270	100.0%	0.0	3.7	0.9	A

Intersection

Main Street/Maple Street

Unsignalized

Direction	Movement	Volume (veh/hr)			GEH	Total Delay (sec/veh)		
		Demand	Served	% Served		Average	Std. Dev.	LOS
NB	Left Turn							
	Through	460	457	99.3%	0.1	7.7	2.9	A
	Right Turn							
	Subtotal	460	457	99.3%	0.1	7.7	2.9	A
SB	Left Turn							
	Through	310	302	97.3%	0.5	4.9	0.6	A
	Right Turn							
	Subtotal	310	302	97.3%	0.5	4.9	0.6	A
EB	Left Turn							
	Through							
	Right Turn							
	Subtotal							
WB	Left Turn	10	0	0.0%	4.5	0.0	0.0	A
	Through							
	Right Turn	10	22	219.0%	3.0	42.7	44.1	E
	Subtotal	20	22	109.5%	0.4	42.7	44.1	E
Total		790	780	98.8%	0.3	7.7	3.1	A

Intersection

Main Street/Beech Street

Unsignalized

Direction	Movement	Volume (veh/hr)			GEH	Total Delay (sec/veh)		
		Demand	Served	% Served		Average	Std. Dev.	LOS
NB	Left Turn	80	139	174.3%	5.7	8.0	1.8	A
	Through	280	414	148.0%	7.2	5.1	1.2	A
	Right Turn							
	Subtotal	360	554	153.8%	9.1	5.8	1.3	A
SB	Left Turn							
	Through	200	354	177.0%	9.2	1.9	0.2	A
	Right Turn	60	98	163.5%	4.3	0.8	0.2	A
	Subtotal	260	452	173.8%	10.2	1.6	0.2	A
EB	Left Turn	30	41	137.0%	1.9	31.5	8.9	D
	Through							
	Right Turn	60	116	193.2%	6.0	15.6	5.1	C
	Subtotal	90	157	174.4%	6.0	19.7	6.0	C
WB	Left Turn							
	Through							
	Right Turn							
	Subtotal							
Total		710	1163	163.8%	14.8	6.1	1.1	A

SimTraffic Post-Processor
Average Results from 20 Runs
Volume and Delay by Movement

Caltrain Electrification
2040 No Project Conditions
AM Peak Hour

Intersection

Main Street/Middlefield Road

Signalized

Direction	Movement	Volume (veh/hr)				Total Delay (sec/veh)		
		Demand	Served	% Served	GEH	Average	Std. Dev.	LOS
NB	Left Turn	50	51	102.0%	0.1	61.4	8.4	E
	Through	400	399	99.6%	0.1	38.6	4.4	D
	Right Turn	30	30	99.7%	0.0	28.6	9.0	C
	Subtotal	480	479	99.9%	0.0	40.5	4.2	D
SB	Left Turn	30	30	101.3%	0.1	51.9	11.0	D
	Through	240	237	98.8%	0.2	30.1	2.6	C
	Right Turn	50	51	101.4%	0.1	13.1	3.3	B
	Subtotal	320	318	99.4%	0.1	29.6	2.1	C
EB	Left Turn	60	56	92.5%	0.6	162.8	65.6	F
	Through	750	747	99.6%	0.1	38.0	6.6	D
	Right Turn	50	50	99.2%	0.1	27.1	13.4	C
	Subtotal	860	852	99.1%	0.3	45.4	8.3	D
WB	Left Turn	20	15	76.5%	1.1	49.3	11.9	D
	Through	750	618	82.4%	5.1	6.8	0.9	A
	Right Turn	130	103	79.4%	2.5	1.0	0.3	A
	Subtotal	900	736	81.8%	5.7	6.9	1.1	A
Total		2560	2386	93.2%	3.5	30.3	2.8	C

Intersection Fair Oaks Lane/Middlefield Road

Unsignalized

Direction	Movement	Volume (veh/hr)			GEH	Total Delay (sec/veh)		
		Demand	Served	% Served		Average	Std. Dev.	LOS
NB	Left Turn	20	8	39.5%	3.2	2537.1	1811.4	F
	Through	10	5	51.0%	1.8	1585.3	1176.8	F
	Right Turn	240	94	39.3%	11.3	1873.1	1815.4	F
	Subtotal	270	107	39.8%	11.8	1897.2	1758.8	F
SB	Left Turn	20	3	14.0%	5.1	6973.9	6904.3	F
	Through	80	12	15.4%	10.0	5431.1	3240.0	F
	Right Turn	60	11	18.7%	8.2	4474.5	1314.7	F
	Subtotal	160	26	16.4%	13.9	4872.4	2040.4	F
EB	Left Turn	10	12	116.0%	0.5	12.7	3.2	B
	Through	740	733	99.0%	0.3	7.7	0.8	A
	Right Turn	250	247	98.8%	0.2	6.1	0.9	A
	Subtotal	1000	991	99.1%	0.3	7.4	0.8	A
WB	Left Turn	220	191	86.9%	2.0	118.0	38.9	F
	Through	590	549	93.0%	1.7	74.9	36.4	F
	Right Turn	20	19	94.0%	0.3	64.2	29.9	F
	Subtotal	830	759	91.4%	2.5	85.4	37.0	F
Total		2260	1884	83.3%	8.3	173.9	21.2	F

Intersection Watkins Avenue/Middlefield Road

Unsignalized

Direction	Movement	Volume (veh/hr)			GEH	Total Delay (sec/veh)		
		Demand	Served	% Served		Average	Std. Dev.	LOS
NB	Left Turn	60	52	87.0%	1.0	103.0	64.5	F
	Through							
	Right Turn	200	205	102.6%	0.4	68.4	68.0	F
	Subtotal	260	257	99.0%	0.2	75.4	67.0	F
SB	Left Turn							
	Through							
	Right Turn							
	Subtotal							
EB	Left Turn							
	Through	900	757	84.1%	5.0	5.1	0.3	A
	Right Turn	100	83	82.9%	1.8	4.3	0.3	A
	Subtotal	1000	840	84.0%	5.3	5.1	0.3	A
WB	Left Turn	60	51	85.0%	1.2	30.0	29.5	D
	Through	770	707	91.8%	2.3	26.3	40.1	D
	Right Turn							
	Subtotal	830	758	91.3%	2.6	26.6	39.3	D
Total		2090	1855	88.8%	5.3	23.6	23.8	C

SimTraffic Post-Processor
Average Results from 20 Runs
Volume and Delay by Movement

Caltrain Electrification
2040 No Project Conditions
AM Peak Hour

Intersection

Linden Avenue-Glenwood Avenue/Middlefield Road

Unsignalized

Direction	Movement	Volume (veh/hr)			GEH	Total Delay (sec/veh)		
		Demand	Served	% Served		Average	Std. Dev.	LOS
NB	Left Turn	70	22	31.1%	7.1	3490.3	1310.2	F
	Through	10	2	18.0%	3.4	3075.0	1861.0	F
	Right Turn	90	27	29.9%	8.3	2986.1	1103.5	F
	Subtotal	170	51	29.7%	11.4	3224.4	1188.4	F
SB	Left Turn	30	10	32.7%	4.5	2513.6	785.3	F
	Through	30	11	35.3%	4.3	2411.5	885.9	F
	Right Turn	40	17	41.5%	4.4	2497.0	966.3	F
	Subtotal	100	37	37.0%	7.6	2482.7	851.3	F
EB	Left Turn	60	52	87.0%	1.0	13.9	1.3	B
	Through	850	740	87.1%	3.9	9.3	0.4	A
	Right Turn	190	170	89.3%	1.5	7.9	0.4	A
	Subtotal	1100	962	87.4%	4.3	9.3	0.4	A
WB	Left Turn	240	245	102.0%	0.3	32.9	7.5	D
	Through	720	712	98.9%	0.3	6.1	2.5	A
	Right Turn	10	10	102.0%	0.1	5.0	4.2	A
	Subtotal	970	967	99.7%	0.1	12.9	3.5	B
Total		2340	2016	86.2%	6.9	122.8	8.6	F

SimTraffic Post-Processor
Average Results from 20 Runs
Volume and Delay by Movement

Caltrain Electrification
2040 No Project Conditions
AM Peak Hour

Intersection California Street/Rengstorff Avenue

Signalized

Direction	Movement	Volume (veh/hr)			GEH	Total Delay (sec/veh)		
		Demand	Served	% Served		Average	Std. Dev.	LOS
NB	Left Turn	430	371	86.3%	3.0	236.4	10.0	F
	Through	810	697	86.1%	4.1	234.6	10.9	F
	Right Turn	300	256	85.2%	2.7	237.9	13.5	F
	Subtotal	1540	1324	85.9%	5.7	235.8	10.3	F
SB	Left Turn	130	133	102.2%	0.3	97.3	21.7	F
	Through	220	216	98.3%	0.3	47.4	2.6	D
	Right Turn	70	73	104.0%	0.3	36.3	5.4	D
	Subtotal	420	422	100.5%	0.1	61.3	7.3	E
EB	Left Turn	110	104	94.6%	0.6	207.1	26.3	F
	Through	720	671	93.1%	1.9	170.9	23.6	F
	Right Turn	170	148	87.1%	1.7	179.7	24.3	F
	Subtotal	1000	923	92.3%	2.5	176.5	23.6	F
WB	Left Turn	200	196	97.8%	0.3	208.4	73.5	F
	Through	520	505	97.2%	0.7	92.5	34.1	F
	Right Turn	250	246	98.4%	0.2	83.1	29.3	F
	Subtotal	970	947	97.6%	0.7	114.3	41.2	F
Total		3930	3615	92.0%	5.1	168.5	10.5	F

Intersection Pennsylvania Street/22nd Street

Unsignalized

Direction	Movement	Volume (veh/hr)			GEH	Total Delay (sec/veh)		
		Demand	Served	% Served		Average	Std. Dev.	LOS
NB	Left Turn	50	51	101.6%	0.1	9.8	1.4	A
	Through	240	234	97.6%	0.4	10.1	0.8	B
	Right Turn	60	57	95.5%	0.4	7.7	0.9	A
	Subtotal	350	342	97.8%	0.4	9.6	0.8	A
SB	Left Turn	20	17	85.0%	0.7	7.3	1.0	A
	Through	200	194	97.1%	0.4	8.7	0.4	A
	Right Turn	10	10	104.0%	0.1	6.1	0.9	A
	Subtotal	230	222	96.3%	0.6	8.4	0.4	A
EB	Left Turn	10	11	113.0%	0.4	6.0	1.1	A
	Through	50	47	94.2%	0.4	7.5	0.9	A
	Right Turn	70	68	96.9%	0.3	5.5	0.7	A
	Subtotal	130	126	97.1%	0.3	6.3	0.7	A
WB	Left Turn	100	101	101.4%	0.1	7.0	0.5	A
	Through	30	32	106.0%	0.3	6.8	0.8	A
	Right Turn	20	21	103.0%	0.1	5.0	1.1	A
	Subtotal	150	154	102.5%	0.3	6.7	0.5	A
Total		860	844	98.1%	0.5	8.3	0.4	A

Intersection Indiana Street/22nd Street

Unsignalized

Direction	Movement	Volume (veh/hr)			GEH	Total Delay (sec/veh)		
		Demand	Served	% Served		Average	Std. Dev.	LOS
NB	Left Turn	20	19	92.5%	0.3	7.1	1.7	A
	Through	90	89	98.6%	0.1	7.3	0.7	A
	Right Turn	70	70	99.4%	0.0	5.0	0.4	A
	Subtotal	180	177	98.2%	0.2	6.4	0.5	A
SB	Left Turn	10	10	97.0%	0.1	5.8	1.1	A
	Through	20	19	93.5%	0.3	6.3	0.7	A
	Right Turn	50	53	105.0%	0.3	4.7	0.4	A
	Subtotal	80	81	101.1%	0.1	5.2	0.4	A
EB	Left Turn	10	10	96.0%	0.1	5.1	0.7	A
	Through	70	62	89.1%	0.9	5.8	0.4	A
	Right Turn	10	12	117.0%	0.5	4.0	0.7	A
	Subtotal	90	84	93.0%	0.7	5.4	0.4	A
WB	Left Turn	10	11	109.0%	0.3	6.3	1.9	A
	Through	190	187	98.6%	0.2	6.4	0.6	A
	Right Turn	10	11	112.0%	0.4	4.5	0.8	A
	Subtotal	210	210	99.8%	0.0	6.3	0.6	A
Total		560	551	98.4%	0.4	6.0	0.4	A

SimTraffic Post-Processor
Average Results from 20 Runs
Volume and Delay by Movement

Caltrain Electrification
2040 No Project Conditions
PM Peak Hour

Intersection Pennsylvania Street/22nd Street

Unsignalized

Direction	Movement	Volume (veh/hr)			GEH	Total Delay (sec/veh)		
		Demand	Served	% Served		Average	Std. Dev.	LOS
NB	Left Turn	30	24	79.3%	1.2	66.1	25.0	F
	Through	240	224	93.4%	1.0	72.5	28.0	F
	Right Turn	10	12	122.0%	0.7	65.3	33.1	F
	Subtotal	280	260	92.9%	1.2	71.6	27.8	F
SB	Left Turn	100	98	97.7%	0.2	30.0	9.4	D
	Through	90	93	102.8%	0.3	30.0	9.0	D
	Right Turn	10	12	118.0%	0.5	25.1	13.5	D
	Subtotal	200	202	101.0%	0.1	29.8	8.9	D
EB	Left Turn	10	10	100.0%	0.0	21.5	7.3	C
	Through	60	58	97.2%	0.2	23.4	5.6	C
	Right Turn	130	137	105.5%	0.6	19.3	3.4	C
	Subtotal	200	205	102.7%	0.4	20.6	3.9	C
WB	Left Turn	10	9	88.0%	0.4	158.4	37.1	F
	Through	240	213	88.7%	1.8	160.8	35.4	F
	Right Turn	120	111	92.8%	0.8	156.4	35.5	F
	Subtotal	370	333	90.0%	2.0	159.3	35.0	F
Total		1050	1001	95.3%	1.5	81.8	15.3	F

Intersection Dubuque Way/Grand Avenue

Signalized

Direction	Movement	Volume (veh/hr)			GEH	Total Delay (sec/veh)		
		Demand	Served	% Served		Average	Std. Dev.	LOS
NB	Left Turn							
	Through							
	Right Turn							
	Subtotal							
SB	Left Turn	30	29	97.7%	0.1	39.6	3.7	D
	Through							
	Right Turn	70	71	102.0%	0.2	15.4	1.8	B
	Subtotal	100	101	100.7%	0.1	22.5	1.6	C
EB	Left Turn	40	34	86.0%	0.9	47.0	6.6	D
	Through	240	244	101.7%	0.3	5.5	0.6	A
	Right Turn							
	Subtotal	280	278	99.4%	0.1	10.6	1.0	B
WB	Left Turn							
	Through	1660	1635	98.5%	0.6	13.7	1.3	B
	Right Turn	90	94	104.1%	0.4	14.5	1.4	B
	Subtotal	1750	1729	98.8%	0.5	13.8	1.3	B
Total		2130	2108	99.0%	0.5	13.8	1.2	B

SimTraffic Post-Processor
Average Results from 20 Runs
Volume and Delay by Movement

Caltrain Electrification
2040 No Project Conditions
PM Peak Hour

Intersection

Linden Avenue-San Mateo Avenue/San Mateo Avenue

Signalized

Direction	Movement	Volume (veh/hr)			GEH	Total Delay (sec/veh)		
		Demand	Served	% Served		Average	Std. Dev.	LOS
NB	Left Turn							
	Through	150	150	99.8%	0.0	11.5	5.2	B
	Right Turn	360	365	101.3%	0.2	1.9	0.2	A
	Subtotal	510	514	100.8%	0.2	4.7	1.6	A
SB	Left Turn	130	126	96.8%	0.4	33.9	6.0	C
	Through	220	226	102.5%	0.4	4.3	0.5	A
	Right Turn							
	Subtotal	350	352	100.4%	0.1	14.9	2.2	B
EB	Left Turn							
	Through							
	Right Turn							
	Subtotal							
WB	Left Turn	220	215	97.8%	0.3	15.2	1.2	B
	Through							
	Right Turn	220	227	103.3%	0.5	13.1	4.5	B
	Subtotal	440	443	100.6%	0.1	14.1	2.8	B
Total		1300	1308	100.6%	0.2	10.6	1.5	B

Intersection

Herman Street/Scott Street

Unsignalized

Direction	Movement	Volume (veh/hr)			GEH	Total Delay (sec/veh)		
		Demand	Served	% Served		Average	Std. Dev.	LOS
NB	Left Turn	10	9	86.0%	0.5	15.0	5.2	B
	Through	130	127	97.8%	0.3	15.4	1.9	C
	Right Turn	140	139	99.4%	0.1	10.6	1.8	B
	Subtotal	280	275	98.2%	0.3	12.9	1.7	B
SB	Left Turn	60	56	93.2%	0.5	18.3	2.5	C
	Through	200	197	98.5%	0.2	18.5	2.5	C
	Right Turn	10	11	108.0%	0.2	12.4	3.5	B
	Subtotal	270	264	97.6%	0.4	18.2	2.4	C
EB	Left Turn	10	9	86.0%	0.5	7.9	1.8	A
	Through	20	20	101.0%	0.0	11.2	1.5	B
	Right Turn	10	12	117.0%	0.5	6.0	2.3	A
	Subtotal	40	41	101.3%	0.1	9.1	0.9	A
WB	Left Turn	210	205	97.6%	0.4	0.2	0.1	A
	Through	30	33	109.0%	0.5	0.3	0.1	A
	Right Turn	30	29	96.0%	0.2	0.1	0.1	A
	Subtotal	270	266	98.7%	0.2	0.2	0.0	A
Total		860	845	98.3%	0.5	10.4	0.9	B

Intersection **Montgomery Avenue/Scott Street**

Unsignalized

Direction	Movement	Volume (veh/hr)			GEH	Total Delay (sec/veh)		
		Demand	Served	% Served		Average	Std. Dev.	LOS
NB	Left Turn	40	42	105.0%	0.3	8.1	0.6	A
	Through	10	12	116.0%	0.5	7.9	0.8	A
	Right Turn	20	18	90.0%	0.5	4.1	0.6	A
	Subtotal	70	72	102.3%	0.2	7.1	0.4	A
SB	Left Turn	10	9	94.0%	0.2	6.8	0.9	A
	Through	10	10	97.0%	0.1	8.5	2.0	A
	Right Turn	20	23	113.0%	0.6	4.2	0.5	A
	Subtotal	40	42	104.3%	0.3	5.8	0.6	A
EB	Left Turn	20	18	87.5%	0.6	2.4	0.4	A
	Through	170	166	97.4%	0.3	0.6	0.1	A
	Right Turn	30	32	106.3%	0.3	0.3	0.2	A
	Subtotal	220	215	97.7%	0.3	0.7	0.1	A
WB	Left Turn	20	19	96.5%	0.2	2.1	0.3	A
	Through	210	201	95.7%	0.6	0.5	0.1	A
	Right Turn	10	10	99.0%	0.0	0.4	0.3	A
	Subtotal	240	230	95.9%	0.6	0.7	0.1	A
Total		570	558	98.0%	0.5	1.9	0.1	A

Intersection **Driveway-Dollar Avenue/Linden Avenue**

Signalized

Direction	Movement	Volume (veh/hr)			GEH	Total Delay (sec/veh)		
		Demand	Served	% Served		Average	Std. Dev.	LOS
NB	Left Turn	100	95	95.1%	0.5	63.8	7.2	E
	Through							
	Right Turn	60	60	100.0%	0.0	51.6	7.4	D
	Subtotal	160	155	96.9%	0.4	59.1	6.9	E
SB	Left Turn	10	9	94.0%	0.2	69.3	12.5	E
	Through							
	Right Turn							
	Subtotal	10	9	94.0%	0.2	69.3	12.5	E
EB	Left Turn							
	Through	280	277	99.0%	0.2	71.3	7.7	E
	Right Turn	150	140	93.1%	0.9	61.3	6.7	E
	Subtotal	430	417	96.9%	0.6	68.0	6.9	E
WB	Left Turn	60	58	96.8%	0.2	6.0	2.3	A
	Through	300	321	106.9%	1.2	5.6	1.4	A
	Right Turn	10	9	94.0%	0.2	1.2	3.0	A
	Subtotal	370	388	104.9%	0.9	5.6	1.2	A
Total		970	969	99.9%	0.0	41.6	2.6	D

SimTraffic Post-Processor
Average Results from 20 Runs
Volume and Delay by Movement

Caltrain Electrification
2040 No Project Conditions
PM Peak Hour

Intersection

San Mateo Avenue/San Bruno Avenue

Signalized

Direction	Movement	Volume (veh/hr)			GEH	Total Delay (sec/veh)		
		Demand	Served	% Served		Average	Std. Dev.	LOS
NB	Left Turn	50	44	88.6%	0.8	50.7	13.5	D
	Through	120	116	96.5%	0.4	42.7	8.1	D
	Right Turn	200	205	102.6%	0.4	13.5	6.2	B
	Subtotal	370	365	98.7%	0.3	27.2	7.7	C
SB	Left Turn	130	126	96.9%	0.4	50.8	5.6	D
	Through	120	116	96.8%	0.4	45.8	5.9	D
	Right Turn	190	182	95.8%	0.6	33.1	6.7	C
	Subtotal	440	424	96.4%	0.8	41.8	6.0	D
EB	Left Turn	120	122	101.7%	0.2	15.6	2.2	B
	Through	530	534	100.7%	0.2	5.0	0.6	A
	Right Turn	30	33	110.3%	0.6	2.8	1.5	A
	Subtotal	680	689	101.3%	0.3	6.8	0.4	A
WB	Left Turn	140	133	95.0%	0.6	59.9	3.7	E
	Through	560	558	99.7%	0.1	23.9	1.7	C
	Right Turn	90	89	98.3%	0.2	20.8	3.1	C
	Subtotal	790	780	98.7%	0.4	29.7	1.3	C
Total		2280	2258	99.0%	0.5	24.6	2.1	C

Intersection **El Camino Real/Millbrae Avenue**

Signalized

Direction	Movement	Volume (veh/hr)			GEH	Total Delay (sec/veh)		
		Demand	Served	% Served		Average	Std. Dev.	LOS
NB	Left Turn	40	39	98.3%	0.1	72.5	9.8	E
	Through	1170	1146	97.9%	0.7	64.2	10.1	E
	Right Turn	750	730	97.4%	0.7	23.0	15.5	C
	Subtotal	1960	1915	97.7%	1.0	48.7	9.8	D
SB	Left Turn	640	532	83.1%	4.5	229.9	36.5	F
	Through	1700	1456	85.6%	6.1	50.6	6.6	D
	Right Turn	70	58	83.1%	1.5	54.0	8.1	D
	Subtotal	2410	2046	84.9%	7.7	97.3	14.0	F
EB	Left Turn	140	142	101.6%	0.2	105.2	26.9	F
	Through	490	495	101.0%	0.2	65.6	25.4	E
	Right Turn	70	68	96.4%	0.3	63.4	27.2	E
	Subtotal	700	705	100.7%	0.2	73.5	24.6	E
WB	Left Turn	650	594	91.4%	2.2	108.1	26.5	F
	Through	750	675	89.9%	2.8	46.7	2.1	D
	Right Turn	830	723	87.1%	3.8	22.5	2.2	C
	Subtotal	2230	1992	89.3%	5.2	56.3	8.6	E
Total		7300	6658	91.2%	7.7	68.5	10.1	E

Intersection **Rollins Road/Millbrae Avenue**

Signalized

Direction	Movement	Volume (veh/hr)			GEH	Total Delay (sec/veh)		
		Demand	Served	% Served		Average	Std. Dev.	LOS
NB	Left Turn	400	374	93.5%	1.3	61.2	3.9	E
	Through	100	93	93.0%	0.7	75.4	3.0	E
	Right Turn	700	634	90.5%	2.6	63.8	2.7	E
	Subtotal	1200	1101	91.7%	2.9	63.9	2.5	E
SB	Left Turn	490	501	102.2%	0.5	78.9	14.4	E
	Through	230	234	101.6%	0.2	71.9	14.9	E
	Right Turn	290	292	100.7%	0.1	30.6	7.9	C
	Subtotal	1010	1026	101.6%	0.5	63.8	7.9	E
EB	Left Turn	200	174	87.0%	1.9	239.7	49.5	F
	Through	1380	1271	92.1%	3.0	150.2	18.9	F
	Right Turn	300	281	93.6%	1.1	117.6	21.7	F
	Subtotal	1880	1726	91.8%	3.6	154.2	17.6	F
WB	Left Turn	420	351	83.5%	3.5	179.8	54.3	F
	Through	1540	1302	84.5%	6.3	134.6	8.6	F
	Right Turn	390	334	85.6%	3.0	9.3	0.5	A
	Subtotal	2350	1986	84.5%	7.8	121.8	6.9	F
Total		6440	5839	90.7%	7.7	110.2	5.9	F

SimTraffic Post-Processor
Average Results from 20 Runs
Volume and Delay by Movement

Caltrain Electrification
2040 No Project Conditions
PM Peak Hour

Intersection

California Drive/Oak Grove

Signalized

Direction	Movement	Volume (veh/hr)			GEH	Total Delay (sec/veh)		
		Demand	Served	% Served		Average	Std. Dev.	LOS
NB	Left Turn	110	105	95.6%	0.5	122.1	25.4	F
	Through	770	774	100.5%	0.1	90.8	23.8	F
	Right Turn	250	243	97.3%	0.4	70.8	21.5	E
	Subtotal	1130	1123	99.3%	0.2	89.4	23.1	F
SB	Left Turn	150	152	101.1%	0.1	149.8	41.9	F
	Through	790	792	100.2%	0.1	63.7	18.5	E
	Right Turn	100	106	105.6%	0.6	30.6	14.9	C
	Subtotal	1040	1049	100.9%	0.3	73.0	19.1	E
EB	Left Turn	30	30	100.3%	0.0	86.3	13.3	F
	Through	290	269	92.8%	1.2	107.2	14.1	F
	Right Turn	80	73	90.6%	0.9	93.4	15.0	F
	Subtotal	400	372	93.0%	1.4	102.8	13.6	F
WB	Left Turn	220	123	56.0%	7.4	26.2	2.6	C
	Through	180	106	58.9%	6.2	24.4	1.5	C
	Right Turn	210	115	54.8%	7.4	13.2	1.4	B
	Subtotal	610	344	56.5%	12.2	21.3	1.0	C
Total		3180	2888	90.8%	5.3	76.9	10.9	E

Intersection

Carolan Ave/Oak Grove

Unsignalized

Direction	Movement	Volume (veh/hr)			GEH	Total Delay (sec/veh)		
		Demand	Served	% Served		Average	Std. Dev.	LOS
NB	Left Turn	90	52	57.2%	4.6	533.4	60.1	F
	Through	130	91	70.2%	3.7	481.3	84.6	F
	Right Turn	50	30	59.0%	3.3	492.2	63.8	F
	Subtotal	270	172	63.8%	6.6	499.5	72.8	F
SB	Left Turn	140	76	54.2%	6.2	188.5	18.4	F
	Through	140	77	55.2%	6.0	192.6	16.4	F
	Right Turn	310	166	53.5%	9.3	416.0	47.0	F
	Subtotal	590	319	54.1%	12.7	308.6	30.0	F
EB	Left Turn	400	385	96.2%	0.8	0.5	0.1	A
	Through	140	151	107.8%	0.9	1.3	0.1	A
	Right Turn	150	142	94.9%	0.6	0.3	0.1	A
	Subtotal	690	678	98.2%	0.5	0.6	0.1	A
WB	Left Turn	90	48	52.9%	5.1	231.6	10.1	F
	Through	210	104	49.5%	8.5	247.5	12.7	F
	Right Turn	70	36	52.0%	4.6	223.1	11.7	F
	Subtotal	370	188	50.8%	10.9	238.7	9.6	F
Total		1920	1357	70.7%	13.9	168.0	8.8	F

SimTraffic Post-Processor
Average Results from 20 Runs
Volume and Delay by Movement

Caltrain Electrification
2040 No Project Conditions
PM Peak Hour

Intersection California Dr/North Lane

Unsignalized

Direction	Movement	Volume (veh/hr)			GEH	Total Delay (sec/veh)		
		Demand	Served	% Served		Average	Std. Dev.	LOS
NB	Left Turn							
	Through	950	969	102.0%	0.6	1.5	0.2	A
	Right Turn	110	110	100.0%	0.0	2.6	1.1	A
	Subtotal	1060	1079	101.8%	0.6	1.6	0.3	A
SB	Left Turn	160	147	91.9%	1.0	32.1	12.6	D
	Through	950	866	91.2%	2.8	4.7	0.4	A
	Right Turn							
	Subtotal	1110	1013	91.3%	3.0	8.7	1.8	A
EB	Left Turn							
	Through							
	Right Turn							
	Subtotal							
WB	Left Turn	50	48	95.8%	0.3	54.2	11.6	F
	Through							
	Right Turn	190	166	87.2%	1.8	7.9	0.6	A
	Subtotal	240	214	89.0%	1.8	18.4	3.5	C
Total		2410	2306	95.7%	2.2	6.2	0.8	A

Intersection Carolan Ave/North Lane

Unsignalized

Direction	Movement	Volume (veh/hr)			GEH	Total Delay (sec/veh)		
		Demand	Served	% Served		Average	Std. Dev.	LOS
NB	Left Turn	130	130	100.2%	0.0	70.5	33.2	F
	Through	170	177	104.1%	0.5	25.2	15.2	D
	Right Turn	10	13	132.0%	0.9	20.5	17.2	C
	Subtotal	310	321	103.4%	0.6	43.7	23.1	E
SB	Left Turn	10	6	63.0%	1.3	26.5	20.0	D
	Through	240	186	77.3%	3.7	23.3	7.8	C
	Right Turn	110	83	75.3%	2.8	29.4	10.6	D
	Subtotal	360	275	76.3%	4.8	25.2	8.2	D
EB	Left Turn	90	92	101.9%	0.2	0.9	0.2	A
	Through	10	16	160.0%	1.7	0.9	0.3	A
	Right Turn	170	158	93.1%	0.9	0.6	0.2	A
	Subtotal	270	266	98.5%	0.3	0.7	0.1	A
WB	Left Turn							
	Through							
	Right Turn							
	Subtotal							
Total		940	861	91.6%	2.6	24.5	10.5	C

Intersection Anita Road/Peninsula Avenue

Unsignalized

Direction	Movement	Volume (veh/hr)			GEH	Total Delay (sec/veh)		
		Demand	Served	% Served		Average	Std. Dev.	LOS
NB	Left Turn							
	Through							
	Right Turn							
	Subtotal							
SB	Left Turn	20	19	92.5%	0.3	47.3	29.2	E
	Through							
	Right Turn	20	18	91.5%	0.4	85.1	59.4	F
	Subtotal	40	37	92.0%	0.5	67.6	48.7	F
EB	Left Turn	20	21	103.5%	0.2	16.1	2.8	C
	Through	670	648	96.7%	0.9	1.0	0.2	A
	Right Turn							
	Subtotal	690	668	96.9%	0.8	1.5	0.3	A
WB	Left Turn							
	Through	730	710	97.2%	0.8	18.8	2.9	C
	Right Turn	10	10	98.0%	0.1	14.8	4.8	B
	Subtotal	740	720	97.2%	0.8	18.8	2.9	C
Total		1470	1425	96.9%	1.2	11.9	2.5	B

Intersection Woodside Way/Villa Terrace

Unsignalized

Direction	Movement	Volume (veh/hr)			GEH	Total Delay (sec/veh)		
		Demand	Served	% Served		Average	Std. Dev.	LOS
NB	Left Turn	10	11	108.0%	0.2	5.1	0.6	A
	Through	20	21	104.0%	0.2	6.0	0.5	A
	Right Turn	10	11	107.0%	0.2	2.7	0.3	A
	Subtotal	40	42	105.8%	0.4	4.9	0.3	A
SB	Left Turn	20	20	98.5%	0.1	5.8	0.6	A
	Through	50	50	100.8%	0.1	7.5	0.5	A
	Right Turn	60	58	96.3%	0.3	3.7	0.4	A
	Subtotal	130	128	98.4%	0.2	5.5	0.4	A
EB	Left Turn	30	29	97.3%	0.1	2.8	0.3	A
	Through	30	32	106.7%	0.4	2.4	0.4	A
	Right Turn	20	22	109.5%	0.4	1.4	0.2	A
	Subtotal	80	83	103.9%	0.3	2.3	0.2	A
WB	Left Turn	10	11	110.0%	0.3	2.2	0.3	A
	Through	30	28	94.0%	0.3	0.7	0.3	A
	Right Turn	20	20	100.0%	0.0	0.2	0.1	A
	Subtotal	60	59	98.7%	0.1	0.8	0.2	A
Total		310	313	100.8%	0.1	3.7	0.2	A

SimTraffic Post-Processor
Average Results from 20 Runs
Volume and Delay by Movement

Caltrain Electrification
2040 No Project Conditions
PM Peak Hour

Intersection N. San Mateo Drive/Villa Terrace

Unsignalized

Direction	Movement	Volume (veh/hr)			GEH	Total Delay (sec/veh)		
		Demand	Served	% Served		Average	Std. Dev.	LOS
NB	Left Turn	10	10	98.0%	0.1	4.9	1.4	A
	Through	610	622	101.9%	0.5	0.6	0.1	A
	Right Turn	50	52	104.2%	0.3	0.8	0.2	A
	Subtotal	670	684	102.0%	0.5	0.7	0.1	A
SB	Left Turn	20	19	96.0%	0.2	6.9	1.0	A
	Through	540	540	100.0%	0.0	3.2	0.4	A
	Right Turn	20	21	105.5%	0.2	4.0	0.7	A
	Subtotal	580	580	100.1%	0.0	3.4	0.4	A
EB	Left Turn	10	9	92.0%	0.3	14.7	4.4	B
	Through	10	11	112.0%	0.4	15.5	2.4	C
	Right Turn	20	22	109.0%	0.4	5.5	1.2	A
	Subtotal	40	42	105.5%	0.3	10.2	1.3	B
WB	Left Turn	40	37	92.5%	0.5	20.9	2.5	C
	Through	20	20	100.5%	0.0	20.4	2.8	C
	Right Turn	40	40	100.3%	0.0	12.5	2.1	B
	Subtotal	100	97	97.2%	0.3	17.2	1.7	C
Total		1390	1403	101.0%	0.4	3.2	0.3	A

Intersection Arundel Road/Peninsula Avenue

Unsignalized

Direction	Movement	Volume (veh/hr)			GEH	Total Delay (sec/veh)		
		Demand	Served	% Served		Average	Std. Dev.	LOS
NB	Left Turn	20	21	103.5%	0.2	57.1	26.8	F
	Through	10	9	92.0%	0.3	42.7	11.9	E
	Right Turn	40	40	101.0%	0.1	21.0	13.0	C
	Subtotal	70	70	100.4%	0.0	34.2	14.0	D
SB	Left Turn	20	19	95.5%	0.2	47.6	18.0	E
	Through	10	10	97.0%	0.1	51.6	21.7	F
	Right Turn	20	19	97.0%	0.1	45.1	13.7	E
	Subtotal	50	48	96.4%	0.3	47.4	14.8	E
EB	Left Turn	10	10	101.0%	0.0	9.1	2.4	A
	Through	620	596	96.1%	1.0	1.2	0.2	A
	Right Turn	60	59	97.8%	0.2	1.0	0.1	A
	Subtotal	690	665	96.4%	1.0	1.3	0.2	A
WB	Left Turn	60	59	98.2%	0.1	20.1	5.7	C
	Through	700	683	97.6%	0.6	18.1	5.1	C
	Right Turn	30	32	106.3%	0.3	16.2	6.3	C
	Subtotal	790	774	98.0%	0.6	18.2	5.1	C
Total		1600	1558	97.3%	1.1	12.6	3.4	B

Intersection **Railroad Ave/1st Ave**

Unsignalized

Direction	Movement	Volume (veh/hr)			GEH	Total Delay (sec/veh)		
		Demand	Served	% Served		Average	Std. Dev.	LOS
NB	Left Turn	30	25	83.0%	1.0	60.5	28.4	F
	Through	20	23	114.0%	0.6	40.9	28.7	E
	Right Turn	10	20	202.0%	2.6	35.0	30.2	D
	Subtotal	60	68	113.2%	1.0	45.2	23.9	E
SB	Left Turn							
	Through							
	Right Turn							
	Subtotal							
EB	Left Turn	10	6	58.0%	1.5	5.7	8.8	A
	Through	380	262	68.9%	6.6	0.6	0.2	A
	Right Turn							
	Subtotal	390	268	68.6%	6.8	0.7	0.3	A
WB	Left Turn							
	Through	310	140	45.3%	11.3	271.2	26.0	F
	Right Turn	10	6	63.0%	1.3	226.7	87.0	F
	Subtotal	320	147	45.8%	11.3	269.2	25.1	F
Total		770	482	62.6%	11.5	88.4	8.5	F

Intersection **S. B. St/1st Ave**

Signalized

Direction	Movement	Volume (veh/hr)			GEH	Total Delay (sec/veh)		
		Demand	Served	% Served		Average	Std. Dev.	LOS
NB	Left Turn	100	88	88.0%	1.2	68.8	14.1	E
	Through	540	513	95.0%	1.2	60.4	10.7	E
	Right Turn	70	64	91.7%	0.7	52.7	8.5	D
	Subtotal	710	665	93.7%	1.7	60.7	10.4	E
SB	Left Turn	70	65	93.4%	0.6	45.6	11.9	D
	Through	480	468	97.4%	0.6	31.6	5.6	C
	Right Turn	50	48	95.2%	0.3	27.7	8.6	C
	Subtotal	600	581	96.8%	0.8	32.9	6.3	C
EB	Left Turn	20	10	50.0%	2.6	192.4	20.2	F
	Through	260	135	51.7%	8.9	201.4	18.7	F
	Right Turn	70	33	47.7%	5.1	177.1	15.8	F
	Subtotal	350	178	50.8%	10.6	196.0	16.7	F
WB	Left Turn	70	37	52.3%	4.6	88.0	15.1	F
	Through	180	113	62.5%	5.6	74.9	11.8	E
	Right Turn	100	54	54.3%	5.2	63.7	19.7	E
	Subtotal	350	203	58.1%	8.8	74.4	12.7	E
Total		2010	1627	81.0%	9.0	66.9	5.5	E

SimTraffic Post-Processor
 Average Results from 20 Runs
 Volume and Delay by Movement

Caltrain Electrification
 2040 No Project Conditions
 PM Peak Hour

Intersection

Transit Center Way/1st St

Unsignalized

Direction	Movement	Volume (veh/hr)			GEH	Total Delay (sec/veh)		
		Demand	Served	% Served		Average	Std. Dev.	LOS
NB	Left Turn	80	53	65.6%	3.4	110.7	18.7	F
	Through	20	14	67.5%	1.6	71.9	17.6	F
	Right Turn	70	45	64.9%	3.2	66.7	7.6	F
	Subtotal	170	111	65.5%	4.9	88.2	11.9	F
SB	Left Turn							
	Through							
	Right Turn							
	Subtotal							
EB	Left Turn	70	43	61.6%	3.6	20.4	5.0	C
	Through	320	226	70.7%	5.7	10.5	1.4	B
	Right Turn	10	8	79.0%	0.7	10.9	10.8	B
	Subtotal	400	277	69.3%	6.7	12.1	1.5	B
WB	Left Turn							
	Through	270	140	51.9%	9.1	49.6	9.8	E
	Right Turn	70	36	51.1%	4.7	22.1	7.5	C
	Subtotal	340	176	51.7%	10.2	43.9	8.2	E
Total		910	565	62.0%	12.7	36.7	2.3	E

Intersection **Railroad Avenue/9th Avenue**

Unsignalized

Direction	Movement	Volume (veh/hr)			GEH	Total Delay (sec/veh)		
		Demand	Served	% Served		Average	Std. Dev.	LOS
NB	Left Turn	50	47	93.4%	0.5	138.2	58.8	F
	Through							
	Right Turn	70	69	98.6%	0.1	123.6	89.8	F
	Subtotal	120	116	96.4%	0.4	129.3	76.3	F
SB	Left Turn							
	Through							
	Right Turn							
	Subtotal							
EB	Left Turn							
	Through	640	624	97.4%	0.7	1.4	0.1	A
	Right Turn	80	81	101.3%	0.1	0.2	0.1	A
	Subtotal	720	705	97.8%	0.6	1.2	0.1	A
WB	Left Turn	10	8	78.0%	0.7	53.0	39.9	F
	Through	580	555	95.7%	1.0	26.9	10.9	D
	Right Turn							
	Subtotal	590	563	95.4%	1.1	27.3	10.9	D
Total		1430	1383	96.7%	1.3	22.7	9.2	C

Intersection **S B Street/9th Avenue**

Signalized

Direction	Movement	Volume (veh/hr)			GEH	Total Delay (sec/veh)		
		Demand	Served	% Served		Average	Std. Dev.	LOS
NB	Left Turn	10	10	98.0%	0.1	35.8	8.9	D
	Through	240	239	99.7%	0.1	30.6	5.8	C
	Right Turn	170	174	102.3%	0.3	26.7	6.5	C
	Subtotal	420	423	100.7%	0.1	29.1	6.0	C
SB	Left Turn	100	98	98.1%	0.2	85.0	16.7	F
	Through	190	196	103.2%	0.4	32.1	10.3	C
	Right Turn	100	101	101.2%	0.1	22.9	8.1	C
	Subtotal	390	395	101.4%	0.3	42.9	11.1	D
EB	Left Turn	50	46	92.8%	0.5	110.8	34.8	F
	Through	450	433	96.2%	0.8	106.7	34.4	F
	Right Turn	20	20	98.5%	0.1	99.9	34.3	F
	Subtotal	520	499	96.0%	0.9	106.8	34.1	F
WB	Left Turn	160	148	92.7%	0.9	49.9	10.9	D
	Through	360	340	94.3%	1.1	20.5	3.3	C
	Right Turn	110	105	95.6%	0.5	15.1	2.9	B
	Subtotal	630	593	94.1%	1.5	26.9	5.1	C
Total		1960	1910	97.5%	1.1	51.5	9.6	D

Intersection

Concar Drive/SR 92 WB Ramps

Signalized

Direction	Movement	Volume (veh/hr)			GEH	Total Delay (sec/veh)		
		Demand	Served	% Served		Average	Std. Dev.	LOS
NB	Left Turn	320	309	96.6%	0.6	23.2	2.1	C
	Through	50	54	107.0%	0.5	16.0	1.8	B
	Right Turn							
	Subtotal	370	363	98.0%	0.4	22.1	1.9	C
SB	Left Turn	30	30	98.3%	0.1	15.2	2.7	B
	Through	60	62	103.2%	0.2	12.7	1.5	B
	Right Turn	10	11	111.0%	0.3	5.6	1.6	A
	Subtotal	100	103	102.5%	0.2	12.7	1.2	B
EB	Left Turn	10	10	103.0%	0.1	28.1	8.3	C
	Through	70	68	96.4%	0.3	32.2	3.6	C
	Right Turn	60	58	96.7%	0.3	15.1	2.9	B
	Subtotal	140	136	97.0%	0.4	24.7	3.3	C
WB	Left Turn	700	684	97.7%	0.6	8.0	0.5	A
	Through	90	89	98.9%	0.1	9.1	1.1	A
	Right Turn	60	60	100.2%	0.0	2.7	0.5	A
	Subtotal	850	833	98.0%	0.6	7.7	0.5	A
Total		1460	1434	98.2%	0.7	13.4	1.1	B

SimTraffic Post-Processor
Average Results from 20 Runs
Volume and Delay by Movement

Caltrain Electrification
2040 No Project Conditions
PM Peak Hour

Intersection Delaware Ave/25th Ave

Signalized

Direction	Movement	Volume (veh/hr)			GEH	Total Delay (sec/veh)		
		Demand	Served	% Served		Average	Std. Dev.	LOS
NB	Left Turn	70	28	39.9%	6.0	1682.4	966.6	F
	Through	10	10	95.0%	0.2	203.1	281.4	F
	Right Turn							
	Subtotal	80	37	46.8%	5.6	1267.3	759.7	F
SB	Left Turn							
	Through	10	6	62.0%	1.3	53.8	14.8	D
	Right Turn	860	701	81.5%	5.7	179.0	17.8	F
	Subtotal	870	707	81.3%	5.8	177.8	17.4	F
EB	Left Turn	760	620	81.6%	5.3	28.7	1.4	C
	Through							
	Right Turn	40	32	79.8%	1.4	10.3	2.9	B
	Subtotal	800	652	81.5%	5.5	27.8	1.4	C
WB	Left Turn							
	Through							
	Right Turn							
	Subtotal							
Total		1750	1397	79.8%	8.9	133.3	14.9	F

Intersection El Camino Real/25th Ave

Signalized

Direction	Movement	Volume (veh/hr)			GEH	Total Delay (sec/veh)		
		Demand	Served	% Served		Average	Std. Dev.	LOS
NB	Left Turn	110	105	95.7%	0.5	130.2	11.1	F
	Through	2060	1855	90.0%	4.6	103.5	3.0	F
	Right Turn	340	302	88.8%	2.1	120.8	3.6	F
	Subtotal	2510	2262	90.1%	5.1	107.0	3.0	F
SB	Left Turn	250	203	81.2%	3.1	503.9	76.5	F
	Through	1840	1571	85.4%	6.5	217.2	19.0	F
	Right Turn	260	229	88.0%	2.0	209.1	18.7	F
	Subtotal	2350	2003	85.2%	7.4	245.5	21.0	F
EB	Left Turn	220	157	71.4%	4.6	381.8	17.2	F
	Through	210	155	73.9%	4.1	418.5	19.4	F
	Right Turn	100	76	76.2%	2.5	339.5	24.6	F
	Subtotal	530	389	73.3%	6.6	388.2	19.0	F
WB	Left Turn	500	369	73.8%	6.3	105.4	7.6	F
	Through	190	146	76.7%	3.4	113.7	1.7	F
	Right Turn	310	229	74.0%	4.9	64.4	7.8	E
	Subtotal	1000	744	74.4%	8.7	94.4	5.4	F
Total		6390	5398	84.5%	12.9	176.8	6.9	F

Intersection El Camino Real/31st Street

Signalized

Direction	Movement	Volume (veh/hr)			GEH	Total Delay (sec/veh)		
		Demand	Served	% Served		Average	Std. Dev.	LOS
NB	Left Turn	160	144	90.1%	1.3	115.4	40.2	F
	Through	1940	1822	93.9%	2.7	48.5	9.2	D
	Right Turn	20	20	100.5%	0.0	16.0	5.2	B
	Subtotal	2120	1986	93.7%	3.0	53.1	11.2	D
SB	Left Turn	340	309	90.8%	1.7	175.6	23.3	F
	Through	2170	1915	88.2%	5.6	193.1	13.3	F
	Right Turn	120	103	85.6%	1.6	169.6	14.3	F
	Subtotal	2630	2326	88.4%	6.1	189.8	14.1	F
EB	Left Turn	260	251	96.7%	0.5	82.6	22.0	F
	Through	40	42	103.8%	0.2	97.9	31.1	F
	Right Turn	160	158	98.6%	0.2	6.3	1.1	A
	Subtotal	460	451	98.0%	0.4	57.3	15.3	E
WB	Left Turn	100	98	98.2%	0.2	39.6	3.1	D
	Through	40	38	95.3%	0.3	43.8	6.3	D
	Right Turn	20	19	92.5%	0.3	20.1	5.0	C
	Subtotal	160	155	96.8%	0.4	38.3	2.8	D
Total		5370	4918	91.6%	6.3	117.7	7.1	F

Intersection El Camino Real/Hillsdale Blvd

Signalized

Direction	Movement	Volume (veh/hr)			GEH	Total Delay (sec/veh)		
		Demand	Served	% Served		Average	Std. Dev.	LOS
NB	Left Turn							
	Through							
	Right Turn							
	Subtotal							
SB	Left Turn	750	660	87.9%	3.4	61.3	2.4	E
	Through							
	Right Turn	250	232	92.7%	1.2	4.6	0.5	A
	Subtotal	1000	891	89.1%	3.5	46.6	2.3	D
EB	Left Turn							
	Through	1040	663	63.7%	12.9	98.0	1.7	F
	Right Turn	130	89	68.2%	3.9	49.6	3.8	D
	Subtotal	1170	751	64.2%	13.5	92.3	1.8	F
WB	Left Turn	520	404	77.7%	5.4	7.5	1.8	A
	Through	1150	904	78.6%	7.7	7.4	0.9	A
	Right Turn							
	Subtotal	1670	1308	78.3%	9.4	7.4	1.0	A
Total		4520	3556	78.7%	15.2	92.0	0.8	F

SimTraffic Post-Processor
Average Results from 20 Runs
Volume and Delay by Movement

Caltrain Electrification
2040 No Project Conditions
PM Peak Hour

Intersection **Curtiss Street/Hillsdale Blvd**

Signalized

Direction	Movement	Volume (veh/hr)			GEH	Total Delay (sec/veh)		
		Demand	Served	% Served		Average	Std. Dev.	LOS
NB	Left Turn	60	58	95.8%	0.3	72.0	9.6	E
	Through	30	27	89.0%	0.6	69.1	7.8	E
	Right Turn	110	112	102.0%	0.2	25.1	5.9	C
	Subtotal	200	196	98.2%	0.3	44.9	6.8	D
SB	Left Turn	40	39	97.8%	0.1	63.9	7.1	E
	Through	10	10	95.0%	0.2	55.0	13.4	D
	Right Turn	20	17	83.0%	0.8	56.8	13.3	E
	Subtotal	70	65	93.1%	0.6	60.7	5.7	E
EB	Left Turn	50	41	81.4%	1.4	26.1	5.2	C
	Through	1380	1088	78.8%	8.3	7.7	1.3	A
	Right Turn	160	121	75.6%	3.3	4.1	1.1	A
	Subtotal	1590	1249	78.6%	9.0	7.9	1.3	A
WB	Left Turn	10	10	99.0%	0.0	155.3	15.8	F
	Through	1700	1291	75.9%	10.6	125.0	3.7	F
	Right Turn	40	33	83.3%	1.1	125.4	9.5	F
	Subtotal	1750	1334	76.2%	10.6	125.2	3.6	F
Total		3610	2845	78.8%	13.5	66.7	1.3	E

SimTraffic Post-Processor
Average Results from 20 Runs
Volume and Delay by Movement

Caltrain Electrification
2040 No Project Conditions
PM Peak Hour

Intersection

El Camino Real/Ralston Avenue

Signalized

Direction	Movement	Volume (veh/hr)			GEH	Total Delay (sec/veh)		
		Demand	Served	% Served		Average	Std. Dev.	LOS
NB	Left Turn	100	73	73.1%	2.9	260.1	27.6	F
	Through	1190	929	78.0%	8.0	203.8	4.8	F
	Right Turn	230	182	79.0%	3.4	37.8	3.0	D
	Subtotal	1520	1184	77.9%	9.2	181.9	4.4	F
SB	Left Turn	450	263	58.5%	9.9	402.3	11.2	F
	Through	1250	773	61.8%	15.0	76.4	2.2	E
	Right Turn	150	93	62.3%	5.1	32.2	3.4	C
	Subtotal	1850	1130	61.1%	18.7	149.0	5.2	F
EB	Left Turn	280	189	67.3%	6.0	234.0	7.6	F
	Through	900	632	70.2%	9.7	264.6	6.7	F
	Right Turn	80	53	65.6%	3.4	282.1	8.2	F
	Subtotal	1260	873	69.3%	11.8	259.0	6.8	F
WB	Left Turn	290	255	87.8%	2.1	85.8	4.0	F
	Through	890	751	84.4%	4.8	211.4	6.4	F
	Right Turn	370	315	85.2%	3.0	45.1	5.8	D
	Subtotal	1550	1321	85.2%	6.0	147.6	5.0	F
Total		6180	4507	72.9%	22.9	178.5	2.2	F

SimTraffic Post-Processor
Average Results from 20 Runs
Volume and Delay by Movement

Caltrain Electrification
2040 No Project Conditions
PM Peak Hour

Intersection

El Camino Real/San Carlos Avenue-Caltrain Station

Signalized

Direction	Movement	Volume (veh/hr)			GEH	Total Delay (sec/veh)		
		Demand	Served	% Served		Average	Std. Dev.	LOS
NB	Left Turn	230	223	96.8%	0.5	81.2	18.5	F
	Through	1060	1054	99.5%	0.2	24.0	3.0	C
	Right Turn	20	21	106.0%	0.3	22.7	4.1	C
	Subtotal	1310	1298	99.1%	0.3	33.8	5.4	C
SB	Left Turn	60	50	83.7%	1.3	74.7	5.7	E
	Through	1240	1132	91.3%	3.2	67.0	3.7	E
	Right Turn	410	384	93.6%	1.3	45.9	3.5	D
	Subtotal	1710	1565	91.5%	3.6	62.1	3.2	E
EB	Left Turn	390	389	99.7%	0.1	33.5	2.2	C
	Through	100	111	111.2%	1.1	38.0	2.9	D
	Right Turn	180	177	98.1%	0.3	30.0	3.3	C
	Subtotal	670	677	101.0%	0.3	33.3	2.3	C
WB	Left Turn	20	19	93.0%	0.3	60.1	8.5	E
	Through	20	22	109.5%	0.4	50.3	8.8	D
	Right Turn	30	31	102.7%	0.1	18.7	3.2	B
	Subtotal	70	71	101.9%	0.2	39.1	4.8	D
Total		3760	3612	96.1%	2.4	46.1	2.7	D

Intersection

California/Broadway

Unsignalized

Direction	Movement	Volume (veh/hr)			GEH	Total Delay (sec/veh)		
		Demand	Served	% Served		Average	Std. Dev.	LOS
NB	Left Turn	50	8	15.2%	7.9	1743.6	904.1	F
	Through	90	15	16.9%	10.3	1545.6	311.7	F
	Right Turn	220	38	17.0%	16.1	1516.3	270.9	F
	Subtotal	360	60	16.8%	20.7	1537.1	268.9	F
SB	Left Turn	120	21	17.6%	11.8	304.4	55.9	F
	Through	110	20	18.4%	11.1	263.8	56.0	F
	Right Turn	60	9	15.5%	8.6	216.0	86.3	F
	Subtotal	290	51	17.4%	18.3	272.8	51.0	F
EB	Left Turn	40	9	21.3%	6.4	146.7	22.6	F
	Through	1110	264	23.8%	32.3	155.3	15.1	F
	Right Turn	190	43	22.8%	13.6	146.6	10.6	F
	Subtotal	1340	316	23.6%	35.6	153.8	14.0	F
WB	Left Turn	360	91	25.1%	18.0	12.3	1.9	B
	Through	990	251	25.4%	29.7	5.6	0.7	A
	Right Turn	200	50	25.2%	13.4	0.7	0.6	A
	Subtotal	1550	392	25.3%	37.2	6.5	0.9	A
Total		3540	819	23.1%	58.3	189.9	17.7	F

Intersection

Arguello Street/Brewster Ave

Signalized

Direction	Movement	Volume (veh/hr)			GEH	Total Delay (sec/veh)		
		Demand	Served	% Served		Average	Std. Dev.	LOS
NB	Left Turn	120	31	25.8%	10.2	89.3	13.2	F
	Through	650	167	25.7%	23.9	63.9	11.9	E
	Right Turn	100	25	25.2%	9.5	25.0	10.5	C
	Subtotal	870	223	25.7%	27.7	62.8	10.1	E
SB	Left Turn	30	14	45.0%	3.5	380.7	36.0	F
	Through	460	215	46.8%	13.3	374.8	34.8	F
	Right Turn	140	67	48.1%	7.1	373.0	32.3	F
	Subtotal	630	296	47.0%	15.5	374.9	33.4	F
EB	Left Turn	160	104	65.1%	4.9	13.4	3.1	B
	Through	200	133	66.4%	5.2	12.9	2.9	B
	Right Turn	40	31	76.5%	1.6	3.8	3.4	A
	Subtotal	400	267	66.9%	7.3	12.1	2.1	B
WB	Left Turn	50	46	92.4%	0.5	53.5	7.7	D
	Through	470	467	99.4%	0.1	51.1	1.9	D
	Right Turn	50	51	101.4%	0.1	47.9	8.1	D
	Subtotal	570	564	99.0%	0.2	51.0	2.1	D
Total		2470	1351	54.7%	25.6	115.9	2.6	F

Intersection

El Camino Real/Broadway

Signalized

Direction	Movement	Volume (veh/hr)			GEH	Total Delay (sec/veh)		
		Demand	Served	% Served		Average	Std. Dev.	LOS
NB	Left Turn	270	196	72.6%	4.8	212.1	37.0	F
	Through	1250	897	71.8%	10.8	127.5	5.7	F
	Right Turn	120	87	72.8%	3.2	122.1	26.8	F
	Subtotal	1640	1180	72.0%	12.2	141.3	8.8	F
SB	Left Turn	490	113	23.0%	21.7	502.8	67.5	F
	Through	1240	326	26.3%	32.7	50.3	8.8	D
	Right Turn	20	5	27.0%	4.1	19.7	12.3	B
	Subtotal	1750	444	25.4%	39.4	166.7	23.3	F
EB	Left Turn	20	3	15.0%	5.0	777.4	361.8	F
	Through	730	108	14.8%	30.4	675.0	110.3	F
	Right Turn	300	44	14.8%	19.5	542.0	105.8	F
	Subtotal	1050	156	14.8%	36.4	639.1	114.1	F
WB	Left Turn	120	29	24.5%	10.5	57.7	9.1	E
	Through	750	189	25.2%	25.9	59.0	2.6	E
	Right Turn	230	55	23.7%	14.7	48.1	5.5	D
	Subtotal	1100	273	24.8%	31.6	56.6	3.0	E
Total		5540	2053	37.1%	56.6	171.5	5.8	F

Intersection

Arguello St/Broadway

Signalized

Direction	Movement	Volume (veh/hr)			GEH	Total Delay (sec/veh)		
		Demand	Served	% Served		Average	Std. Dev.	LOS
NB	Left Turn	80	29	36.1%	6.9	283.4	49.3	F
	Through	220	83	37.9%	11.1	248.3	47.0	F
	Right Turn	360	141	39.1%	13.9	231.4	28.9	F
	Subtotal	660	253	38.3%	19.1	242.4	30.7	F
SB	Left Turn	90	44	48.7%	5.6	128.0	46.7	F
	Through	260	137	52.5%	8.8	112.7	40.0	F
	Right Turn	200	110	54.8%	7.3	87.6	38.4	F
	Subtotal	550	290	52.7%	12.7	105.6	39.9	F
EB	Left Turn	320	70	21.7%	18.0	17.9	3.7	B
	Through	980	230	23.5%	30.5	19.9	1.5	B
	Right Turn	150	34	22.7%	12.1	2.8	1.2	A
	Subtotal	1450	334	23.0%	37.4	17.7	0.6	B
WB	Left Turn	30	4	13.7%	6.3	223.9	130.8	F
	Through	1270	243	19.1%	37.4	171.5	22.6	F
	Right Turn	330	63	19.2%	19.0	70.3	11.2	E
	Subtotal	1630	310	19.0%	42.4	151.8	19.9	F
Total		4290	1186	27.7%	59.3	121.9	14.0	F

SimTraffic Post-Processor
Average Results from 20 Runs
Volume and Delay by Movement

Caltrain Electrification
2040 No Project Conditions
PM Peak Hour

Intersection

El Camino Real/James

Signalized

Direction	Movement	Volume (veh/hr)			GEH	Total Delay (sec/veh)		
		Demand	Served	% Served		Average	Std. Dev.	LOS
NB	Left Turn	137	97	70.9%	3.7	231.8	17.2	F
	Through	1505	1045	69.4%	12.9	233.0	19.4	F
	Right Turn	42	30	71.9%	2.0	147.8	23.0	F
	Subtotal	1684	1172	69.6%	13.6	230.7	18.8	F
SB	Left Turn	126	31	24.6%	10.7	68.8	18.7	E
	Through	1537	363	23.6%	38.1	19.4	2.5	B
	Right Turn	84	19	22.5%	9.1	9.2	2.3	A
	Subtotal	1747	413	23.7%	40.6	22.6	2.7	C
EB	Left Turn	95	92	96.4%	0.4	96.3	12.7	F
	Through	63	64	101.3%	0.1	26.9	6.8	C
	Right Turn	105	100	95.0%	0.5	5.6	1.5	A
	Subtotal	263	255	97.0%	0.5	43.6	6.7	D
WB	Left Turn	126	32	25.0%	10.6	33.9	7.6	C
	Through	463	110	23.8%	20.8	41.0	4.2	D
	Right Turn	126	34	26.7%	10.3	60.2	8.5	E
	Subtotal	715	176	24.6%	25.6	43.3	4.0	D
Total		4409	2016	45.7%	42.2	147.9	8.9	F

SimTraffic Post-Processor
Average Results from 20 Runs
Volume and Delay by Movement

Caltrain Electrification
2040 No Project Conditions
PM Peak Hour

Intersection El Camino Real/Atherton Avenue-Fair Oaks Lane

Signalized

Direction	Movement	Volume (veh/hr)			GEH	Total Delay (sec/veh)		
		Demand	Served	% Served		Average	Std. Dev.	LOS
NB	Left Turn	310	240	77.3%	4.3	425.5	91.3	F
	Through	1910	1762	92.2%	3.5	33.7	5.5	C
	Right Turn	80	79	98.1%	0.2	31.6	4.5	C
	Subtotal	2300	2080	90.4%	4.7	78.8	14.5	E
SB	Left Turn	40	38	94.8%	0.3	124.7	33.5	F
	Through	1720	1653	96.1%	1.6	146.1	32.2	F
	Right Turn	80	75	94.1%	0.5	161.8	36.8	F
	Subtotal	1840	1766	96.0%	1.7	146.3	32.3	F
EB	Left Turn	140	133	95.1%	0.6	67.5	14.5	E
	Through	110	111	100.6%	0.1	65.4	12.9	E
	Right Turn	150	147	97.7%	0.3	48.9	16.4	D
	Subtotal	400	390	97.6%	0.5	59.9	14.7	E
WB	Left Turn	40	39	97.5%	0.2	105.1	40.7	F
	Through	110	109	99.1%	0.1	104.7	38.2	F
	Right Turn	90	90	100.0%	0.0	50.9	26.2	D
	Subtotal	240	238	99.2%	0.1	84.4	33.5	F
Total		4780	4474	93.6%	4.5	104.2	10.9	F

Intersection El Camino Real/Watkins Avenue

Unsignalized

Direction	Movement	Volume (veh/hr)			GEH	Total Delay (sec/veh)		
		Demand	Served	% Served		Average	Std. Dev.	LOS
NB	Left Turn							
	Through	2110	2091	99.1%	0.4	6.8	6.9	A
	Right Turn	70	74	105.7%	0.5	5.0	2.3	A
	Subtotal	2180	2165	99.3%	0.3	6.8	6.8	A
SB	Left Turn	50	44	88.4%	0.8	80.9	69.0	F
	Through	1860	1795	96.5%	1.5	6.0	0.5	A
	Right Turn							
	Subtotal	1910	1839	96.3%	1.6	7.7	1.7	A
EB	Left Turn							
	Through							
	Right Turn							
	Subtotal							
WB	Left Turn	100	15	14.7%	11.3	3142.0	869.9	F
	Through							
	Right Turn	190	29	15.1%	15.4	3409.8	2260.7	F
	Subtotal	290	43	14.9%	19.1	3217.1	1494.6	F
Total		4380	4048	92.4%	5.1	37.1	4.5	E

Intersection

El Camino Real/Glenwood

Signalized

Direction	Movement	Volume (veh/hr)			GEH	Total Delay (sec/veh)		
		Demand	Served	% Served		Average	Std. Dev.	LOS
NB	Left Turn	120	77	64.2%	4.3	51.7	21.7	D
	Through	1680	1128	67.1%	14.7	21.0	5.9	C
	Right Turn	40	25	61.5%	2.7	16.6	5.8	B
	Subtotal	1840	1229	66.8%	15.6	22.7	5.7	C
SB	Left Turn	310	222	71.7%	5.4	378.9	62.1	F
	Through	1190	907	76.2%	8.7	205.9	47.2	F
	Right Turn	350	256	73.2%	5.4	135.2	33.1	F
	Subtotal	1850	1386	74.9%	11.5	220.9	44.6	F
EB	Left Turn	330	237	71.9%	5.5	307.5	29.9	F
	Through	160	119	74.3%	3.5	308.4	22.7	F
	Right Turn	120	96	80.2%	2.3	253.9	52.7	F
	Subtotal	610	452	74.1%	6.8	296.3	30.6	F
WB	Left Turn	90	66	73.7%	2.7	656.3	86.9	F
	Through	250	180	72.1%	4.8	643.4	76.8	F
	Right Turn	120	89	74.1%	3.0	625.4	72.9	F
	Subtotal	460	336	72.9%	6.2	640.4	75.0	F
Total		4760	3403	71.5%	21.2	200.1	24.2	F

Intersection

El Camino Real/Oak Grove

Signalized

Direction	Movement	Volume (veh/hr)			GEH	Total Delay (sec/veh)		
		Demand	Served	% Served		Average	Std. Dev.	LOS
NB	Left Turn	120	81	67.7%	3.9	38.1	3.8	D
	Through	1490	1044	70.0%	12.5	12.3	3.1	B
	Right Turn	200	136	68.1%	4.9	78.9	61.5	E
	Subtotal	1810	1261	69.7%	14.0	20.6	7.8	C
SB	Left Turn	240	162	67.5%	5.5	227.0	68.4	F
	Through	1060	805	75.9%	8.4	79.9	36.4	E
	Right Turn	100	75	75.0%	2.7	46.2	45.4	D
	Subtotal	1400	1042	74.4%	10.3	100.5	35.9	F
EB	Left Turn	130	89	68.8%	3.9	340.1	58.7	F
	Through	240	160	66.8%	5.6	405.4	98.0	F
	Right Turn	150	101	67.4%	4.4	350.2	84.6	F
	Subtotal	520	351	67.4%	8.1	372.4	81.8	F
WB	Left Turn	100	40	39.8%	7.2	107.5	58.4	F
	Through	200	84	42.1%	9.7	55.3	6.5	E
	Right Turn	220	94	42.6%	10.1	24.8	8.9	C
	Subtotal	520	218	41.9%	15.7	51.8	13.6	D
Total		4250	2871	67.6%	23.1	94.6	24.0	F

Intersection El Camino Real/Santa Cruz Ave

Signalized

Direction	Movement	Volume (veh/hr)			GEH	Total Delay (sec/veh)		
		Demand	Served	% Served		Average	Std. Dev.	LOS
NB	Left Turn							
	Through	1570	1142	72.7%	11.6	13.5	9.4	B
	Right Turn	150	113	75.1%	3.3	39.6	21.4	D
	Subtotal	1720	1254	72.9%	12.1	16.0	9.6	B
SB	Left Turn							
	Through	1210	871	72.0%	10.5	48.9	26.1	D
	Right Turn	100	77	76.6%	2.5	20.8	11.0	C
	Subtotal	1310	948	72.3%	10.8	46.7	24.9	D
EB	Left Turn	180	82	45.7%	8.5	412.1	90.1	F
	Through	240	107	44.8%	10.1	620.1	185.2	F
	Right Turn	220	99	45.0%	9.6	382.0	97.2	F
	Subtotal	640	289	45.1%	16.3	479.0	126.3	F
WB	Left Turn	130	81	62.3%	4.8	67.0	21.3	E
	Through	160	104	64.8%	4.9	71.2	24.9	E
	Right Turn	60	35	59.0%	3.6	57.1	17.5	E
	Subtotal	350	220	62.9%	7.7	67.5	22.3	E
Total		4020	2711	67.4%	22.6	78.4	15.8	E

Intersection Merril St/Santa Cruz Ave

Unsignalized

Direction	Movement	Volume (veh/hr)			GEH	Total Delay (sec/veh)		
		Demand	Served	% Served		Average	Std. Dev.	LOS
NB	Left Turn	150	92	61.3%	5.3	50.6	29.7	F
	Through	20	14	69.5%	1.5	59.2	46.4	F
	Right Turn	10	7	71.0%	1.0	45.7	28.1	E
	Subtotal	180	113	62.8%	5.5	51.3	30.7	F
SB	Left Turn	10	5	53.0%	1.7	221.5	70.7	F
	Through	270	144	53.4%	8.7	243.4	42.3	F
	Right Turn	150	77	51.3%	6.9	238.2	54.9	F
	Subtotal	430	226	52.7%	11.2	241.2	45.8	F
EB	Left Turn	300	169	56.4%	8.5	112.1	14.2	F
	Through	60	32	53.8%	4.1	113.0	13.7	F
	Right Turn	30	20	67.3%	2.0	121.7	30.1	F
	Subtotal	390	222	56.9%	9.6	112.7	13.1	F
WB	Left Turn	10	12	116.0%	0.5	144.4	40.5	F
	Through	50	51	102.6%	0.2	109.5	44.2	F
	Right Turn	40	44	110.0%	0.6	114.5	50.3	F
	Subtotal	100	107	106.9%	0.7	114.8	41.9	F
Total		1100	668	60.7%	14.5	145.3	21.2	F

SimTraffic Post-Processor
 Average Results from 20 Runs
 Volume and Delay by Movement

Caltrain Electrification
 2040 No Project Conditions
 PM Peak Hour

Intersection

Ravenswood Ave/Laurel St

Signalized

Direction	Movement	Volume (veh/hr)			GEH	Total Delay (sec/veh)		
		Demand	Served	% Served		Average	Std. Dev.	LOS
NB	Left Turn	200	182	90.8%	1.3	134.7	97.0	F
	Through	147	141	95.7%	0.5	102.2	90.2	F
	Right Turn	53	49	92.1%	0.6	101.3	90.9	F
	Subtotal	400	371	92.8%	1.5	118.0	93.8	F
SB	Left Turn	168	77	45.9%	8.2	2623.9	270.8	F
	Through	137	62	45.2%	7.5	2646.6	306.4	F
	Right Turn	274	123	44.9%	10.7	2705.2	371.3	F
	Subtotal	579	262	45.3%	15.5	2665.5	316.3	F
EB	Left Turn	211	124	58.5%	6.8	122.7	35.5	F
	Through	979	583	59.6%	14.2	30.7	6.6	C
	Right Turn	137	81	59.1%	5.4	26.5	6.2	C
	Subtotal	1327	788	59.3%	16.6	44.8	11.3	D
WB	Left Turn	42	28	66.9%	2.3	216.8	37.1	F
	Through	663	500	75.4%	6.8	201.0	36.6	F
	Right Turn	179	137	76.6%	3.3	199.6	37.7	F
	Subtotal	884	665	75.3%	7.9	201.3	36.5	F
Total		3190	2086	65.4%	21.5	436.0	43.3	F

Intersection

High Street/University Ave

Signalized

Direction	Movement	Volume (veh/hr)			GEH	Total Delay (sec/veh)		
		Demand	Served	% Served		Average	Std. Dev.	LOS
NB	Left Turn							
	Through							
	Right Turn							
	Subtotal							
SB	Left Turn	20	20	101.0%	0.0	44.3	9.0	D
	Through	70	76	108.1%	0.7	30.3	3.8	C
	Right Turn	310	311	100.4%	0.1	33.1	7.3	C
	Subtotal	400	407	101.8%	0.4	33.1	6.0	C
EB	Left Turn							
	Through	780	702	90.0%	2.9	24.3	5.0	C
	Right Turn	510	447	87.7%	2.9	11.7	4.2	B
	Subtotal	1290	1149	89.1%	4.0	19.4	4.4	B
WB	Left Turn	50	43	85.0%	1.1	45.4	10.6	D
	Through	740	695	93.9%	1.7	26.9	4.4	C
	Right Turn							
	Subtotal	790	738	93.4%	1.9	28.0	4.9	C
Total		2480	2294	92.5%	3.8	24.5	2.3	C

SimTraffic Post-Processor
Average Results from 20 Runs
Volume and Delay by Movement

Caltrain Electrification
2040 No Project Conditions
PM Peak Hour

Intersection

Showers Drive/Pacchetti Way

Signalized

Direction	Movement	Volume (veh/hr)			GEH	Total Delay (sec/veh)		
		Demand	Served	% Served		Average	Std. Dev.	LOS
NB	Left Turn	10	9	88.0%	0.4	25.2	4.6	C
	Through	30	30	101.3%	0.1	3.1	0.9	A
	Right Turn							
	Subtotal	40	39	98.0%	0.1	8.1	2.1	A
SB	Left Turn							
	Through	210	217	103.5%	0.5	4.3	0.5	A
	Right Turn	50	47	94.0%	0.4	2.2	0.8	A
	Subtotal	260	264	101.7%	0.3	3.9	0.5	A
EB	Left Turn	20	19	96.5%	0.2	13.6	1.8	B
	Through							
	Right Turn	10	13	126.0%	0.8	3.5	1.1	A
	Subtotal	30	32	106.3%	0.3	9.7	1.6	A
WB	Left Turn							
	Through							
	Right Turn							
	Subtotal							
Total		330	335	101.6%	0.3	4.9	0.5	A

SimTraffic Post-Processor
Average Results from 20 Runs
Volume and Delay by Movement

Caltrain Electrification
2040 No Project Conditions
PM Peak Hour

Intersection Hope Street/Evelyn Ave

Signalized

Direction	Movement	Volume (veh/hr)			GEH	Total Delay (sec/veh)		
		Demand	Served	% Served		Average	Std. Dev.	LOS
NB	Left Turn	60	54	89.8%	0.8	20.1	3.2	C
	Through							
	Right Turn	160	161	100.8%	0.1	6.2	0.4	A
	Subtotal	220	215	97.8%	0.3	9.7	0.9	A
SB	Left Turn							
	Through							
	Right Turn							
	Subtotal							
EB	Left Turn							
	Through	240	193	80.3%	3.2	1.8	0.2	A
	Right Turn	20	16	80.0%	0.9	0.7	0.3	A
	Subtotal	260	209	80.3%	3.4	1.7	0.2	A
WB	Left Turn	70	67	95.0%	0.4	4.5	1.4	A
	Through	190	187	98.6%	0.2	2.6	0.6	A
	Right Turn							
	Subtotal	260	254	97.6%	0.4	3.0	0.5	A
Total		740	678	91.6%	2.3	4.7	0.3	A

Intersection Castro Street/Villa Street

Signalized

Direction	Movement	Volume (veh/hr)			GEH	Total Delay (sec/veh)		
		Demand	Served	% Served		Average	Std. Dev.	LOS
NB	Left Turn	40	40	99.5%	0.0	177.9	55.0	F
	Through	250	245	98.0%	0.3	151.1	32.4	F
	Right Turn	90	86	96.0%	0.4	142.2	34.5	F
	Subtotal	380	371	97.7%	0.4	151.8	33.4	F
SB	Left Turn	220	178	81.0%	3.0	192.8	20.7	F
	Through	240	209	87.3%	2.0	55.7	6.8	E
	Right Turn	200	172	85.9%	2.1	46.3	7.4	D
	Subtotal	660	559	84.8%	4.1	96.5	11.7	F
EB	Left Turn	430	275	64.0%	8.2	196.4	16.2	F
	Through	240	160	66.5%	5.7	191.2	13.7	F
	Right Turn	40	25	63.5%	2.6	188.1	13.3	F
	Subtotal	710	460	64.8%	10.3	194.1	14.8	F
WB	Left Turn	130	132	101.7%	0.2	28.0	3.5	C
	Through	300	307	102.4%	0.4	27.1	3.5	C
	Right Turn	60	57	94.8%	0.4	21.4	2.6	C
	Subtotal	490	496	101.3%	0.3	26.7	3.1	C
Total		2240	1887	84.3%	7.8	112.5	6.8	F

SimTraffic Post-Processor
Average Results from 20 Runs
Volume and Delay by Movement

Caltrain Electrification
2040 No Project Conditions
PM Peak Hour

Intersection

Frances St/Evelyn Ave

Signalized

Direction	Movement	Volume (veh/hr)			GEH	Total Delay (sec/veh)		
		Demand	Served	% Served		Average	Std. Dev.	LOS
NB	Left Turn	30	29	96.0%	0.2	44.0	7.6	D
	Through	30	30	101.0%	0.1	40.0	5.8	D
	Right Turn	20	21	103.5%	0.2	27.5	9.2	C
	Subtotal	80	80	99.8%	0.0	38.5	5.6	D
SB	Left Turn	80	83	104.3%	0.4	53.6	6.9	D
	Through	20	17	87.0%	0.6	54.2	10.4	D
	Right Turn	50	52	103.6%	0.3	34.9	7.2	C
	Subtotal	150	153	101.7%	0.2	47.0	6.4	D
EB	Left Turn	80	79	98.9%	0.1	157.7	37.1	F
	Through	810	806	99.5%	0.1	58.3	10.3	E
	Right Turn	80	73	91.1%	0.8	54.6	9.2	D
	Subtotal	970	958	98.8%	0.4	66.4	12.2	E
WB	Left Turn	80	78	97.3%	0.2	86.7	15.7	F
	Through	410	428	104.3%	0.9	13.0	2.4	B
	Right Turn	150	152	101.5%	0.2	7.7	2.8	A
	Subtotal	640	658	102.7%	0.7	20.5	4.1	C
Total		1840	1848	100.4%	0.2	47.3	7.1	D

Intersection **Lawrence Expressway/Kifer Road**

Signalized

Direction	Movement	Volume (veh/hr)			GEH	Total Delay (sec/veh)		
		Demand	Served	% Served		Average	Std. Dev.	LOS
NB	Left Turn	190	131	68.7%	4.7	497.9	28.3	F
	Through	2230	1472	66.0%	17.6	567.9	14.8	F
	Right Turn	280	184	65.8%	6.3	659.6	15.7	F
	Subtotal	2700	1786	66.2%	19.3	572.3	15.0	F
SB	Left Turn	970	389	40.1%	22.3	422.5	7.5	F
	Through	3690	1565	42.4%	41.5	78.0	20.3	E
	Right Turn	110	46	41.5%	7.3	55.8	26.1	E
	Subtotal	4770	1999	41.9%	47.6	144.8	13.1	F
EB	Left Turn	350	225	64.2%	7.4	400.6	176.3	F
	Through	730	496	67.9%	9.5	44.9	3.2	D
	Right Turn	1380	930	67.4%	13.3	199.7	3.3	F
	Subtotal	2460	1650	67.1%	17.9	180.7	24.1	F
WB	Left Turn	800	797	99.7%	0.1	186.7	67.0	F
	Through	1110	1070	96.4%	1.2	157.5	12.4	F
	Right Turn	250	234	93.8%	1.0	159.1	15.5	F
	Subtotal	2160	2102	97.3%	1.3	168.8	23.9	F
Total		12090	7537	62.3%	46.0	260.7	11.6	F

Intersection **Lawrence Expressway/Reed Ave-Monroe St**

Signalized

Direction	Movement	Volume (veh/hr)			GEH	Total Delay (sec/veh)		
		Demand	Served	% Served		Average	Std. Dev.	LOS
NB	Left Turn	200	160	80.0%	3.0	449.2	96.1	F
	Through	2260	1659	73.4%	13.6	274.1	22.7	F
	Right Turn	510	387	75.9%	5.8	193.4	18.0	F
	Subtotal	2970	2205	74.3%	15.0	272.6	20.1	F
SB	Left Turn	750	424	56.5%	13.5	186.3	71.2	F
	Through	4700	2661	56.6%	33.6	46.7	3.9	D
	Right Turn	420	234	55.7%	10.3	27.4	2.7	C
	Subtotal	5870	3319	56.5%	37.6	63.2	11.2	E
EB	Left Turn	340	150	44.0%	12.2	1387.5	289.9	F
	Through	820	560	68.2%	9.9	340.1	46.1	F
	Right Turn	540	362	67.0%	8.4	181.3	47.8	F
	Subtotal	1700	1071	63.0%	16.9	433.6	28.2	F
WB	Left Turn	510	388	76.1%	5.8	419.5	28.8	F
	Through	440	342	77.7%	5.0	228.4	13.9	F
	Right Turn	100	79	79.2%	2.2	97.0	11.4	F
	Subtotal	1050	809	77.0%	7.9	307.8	13.7	F
Total		11590	7404	63.9%	43.0	205.7	10.2	F

SimTraffic Post-Processor
Average Results from 20 Runs
Volume and Delay by Movement

Caltrain Electrification
2040 No Project Conditions
PM Peak Hour

Intersection El Camino Real/Railroad Ave

Signalized

Direction	Movement	Volume (veh/hr)			GEH	Total Delay (sec/veh)		
		Demand	Served	% Served		Average	Std. Dev.	LOS
NB	Left Turn	280	273	97.5%	0.4	60.1	9.2	E
	Through	1100	1138	103.5%	1.1	15.0	1.4	B
	Right Turn	30	30	101.3%	0.1	16.7	2.1	B
	Subtotal	1410	1442	102.2%	0.8	23.7	2.3	C
SB	Left Turn	120	123	102.2%	0.2	46.9	5.6	D
	Through	1870	1860	99.5%	0.2	43.4	3.2	D
	Right Turn	260	259	99.6%	0.1	55.3	5.1	E
	Subtotal	2250	2241	99.6%	0.2	45.0	3.3	D
EB	Left Turn	90	85	94.0%	0.6	40.9	12.0	D
	Through	10	10	103.0%	0.1	29.1	8.3	C
	Right Turn	190	187	98.4%	0.2	16.0	2.0	B
	Subtotal	290	282	97.2%	0.5	23.9	5.1	C
WB	Left Turn	110	111	100.8%	0.1	38.1	2.8	D
	Through	10	9	88.0%	0.4	21.7	11.2	C
	Right Turn	40	39	98.3%	0.1	8.1	3.4	A
	Subtotal	160	159	99.4%	0.1	29.7	2.0	C
Total		4110	4124	100.3%	0.2	35.5	1.7	D

Intersection Santa Clara Street/Cahill Street

Signalized

Direction	Movement	Volume (veh/hr)			GEH	Total Delay (sec/veh)		
		Demand	Served	% Served		Average	Std. Dev.	LOS
NB	Left Turn	170	100	58.8%	6.0	118.1	48.4	F
	Through	10	15	151.0%	1.4	69.9	65.1	E
	Right Turn	370	213	57.7%	9.2	147.4	61.7	F
	Subtotal	550	329	59.7%	10.6	134.8	57.7	F
SB	Left Turn	20	20	101.0%	0.0	71.7	18.2	E
	Through	10	10	102.0%	0.1	64.3	21.9	E
	Right Turn	20	22	109.5%	0.4	26.9	18.0	C
	Subtotal	50	52	104.6%	0.3	51.7	19.0	D
EB	Left Turn							
	Through	1350	469	34.7%	29.2	194.8	27.8	F
	Right Turn	200	66	32.9%	11.6	229.7	45.3	F
	Subtotal	1550	534	34.5%	31.5	199.0	27.7	F
WB	Left Turn	180	144	80.2%	2.8	59.6	13.2	E
	Through	870	754	86.7%	4.1	8.4	1.4	A
	Right Turn	10	9	88.0%	0.4	5.2	3.3	A
	Subtotal	1060	907	85.6%	4.9	16.6	2.5	B
Total		3210	1822	56.8%	27.7	92.2	14.3	F

Intersection San Fernando Street/Montgomery Street

Signalized

Direction	Movement	Volume (veh/hr)			GEH	Total Delay (sec/veh)		
		Demand	Served	% Served		Average	Std. Dev.	LOS
NB	Left Turn							
	Through							
	Right Turn							
	Subtotal							
SB	Left Turn	140	77	55.1%	6.0	273.0	32.6	F
	Through	1950	1144	58.7%	20.5	250.9	22.6	F
	Right Turn	50	29	57.0%	3.4	236.5	84.4	F
	Subtotal	2140	1249	58.4%	21.6	251.8	22.3	F
EB	Left Turn							
	Through	240	139	57.9%	7.3	101.3	13.6	F
	Right Turn	260	145	55.7%	8.1	100.2	18.7	F
	Subtotal	500	284	56.7%	10.9	100.8	14.8	F
WB	Left Turn	280	201	71.6%	5.1	90.3	16.1	F
	Through	340	255	75.0%	4.9	81.8	14.4	F
	Right Turn							
	Subtotal	620	456	73.5%	7.1	85.6	14.0	F
Total		3260	1989	61.0%	24.8	192.2	17.7	F

SimTraffic Post-Processor
Average Results from 20 Runs
Volume and Delay by Movement

Caltrain Electrification
2040 No Project Conditions
PM Peak Hour

Intersection

Lick Avenue-Shadow Run Drive/Alma Avenue

Signalized

Direction	Movement	Volume (veh/hr)			GEH	Total Delay (sec/veh)		
		Demand	Served	% Served		Average	Std. Dev.	LOS
NB	Left Turn	30	29	97.7%	0.1	65.9	9.4	E
	Through	10	10	101.0%	0.0	55.9	8.6	E
	Right Turn	20	23	112.5%	0.5	18.0	5.4	B
	Subtotal	60	62	103.2%	0.2	46.6	5.9	D
SB	Left Turn	660	532	80.5%	5.3	93.5	2.1	F
	Through	60	48	80.7%	1.6	59.6	4.0	E
	Right Turn	120	104	86.3%	1.6	52.3	5.4	D
	Subtotal	840	684	81.4%	5.7	84.8	1.7	F
EB	Left Turn	100	94	94.0%	0.6	102.1	11.0	F
	Through	810	833	102.8%	0.8	44.6	2.8	D
	Right Turn	40	42	105.5%	0.3	41.1	4.5	D
	Subtotal	950	969	102.0%	0.6	50.1	3.8	D
WB	Left Turn	20	19	93.5%	0.3	128.7	15.6	F
	Through	890	886	99.6%	0.1	67.0	12.7	E
	Right Turn	100	99	99.2%	0.1	70.1	15.1	E
	Subtotal	1010	1004	99.4%	0.2	68.4	12.9	E
Total		2860	2718	95.0%	2.7	65.5	5.5	E

Intersection 7th Street/Mission Bay

Signalized

Direction	Movement	Volume (veh/hr)			GEH	Total Delay (sec/veh)		
		Demand	Served	% Served		Average	Std. Dev.	LOS
NB	Left Turn	10	9	93.0%	0.2	27.5	9.5	C
	Through	1340	1329	99.2%	0.3	14.4	0.9	B
	Right Turn	80	80	100.5%	0.0	20.9	4.3	C
	Subtotal	1430	1419	99.2%	0.3	14.9	0.9	B
SB	Left Turn	120	117	97.1%	0.3	80.8	3.5	F
	Through	340	341	100.2%	0.0	5.9	0.6	A
	Right Turn	10	11	110.0%	0.3	3.7	1.7	A
	Subtotal	470	468	99.6%	0.1	24.5	1.6	C
EB	Left Turn							
	Through							
	Right Turn							
	Subtotal							
WB	Left Turn	40	39	97.5%	0.2	2.9	1.6	A
	Through							
	Right Turn	90	88	98.1%	0.2	0.6	0.0	A
	Subtotal	130	127	97.9%	0.2	1.3	0.5	A
Total		2030	2014	99.2%	0.4	16.2	0.6	B

Intersection Berry Street/Mission Bay

Signalized

Direction	Movement	Volume (veh/hr)			GEH	Total Delay (sec/veh)		
		Demand	Served	% Served		Average	Std. Dev.	LOS
NB	Left Turn							
	Through							
	Right Turn							
	Subtotal							
SB	Left Turn							
	Through							
	Right Turn	130	127	97.5%	0.3	21.4	3.3	C
	Subtotal	130	127	97.5%	0.3	21.4	3.3	C
EB	Left Turn	200	196	98.1%	0.3	0.5	0.2	A
	Through							
	Right Turn							
	Subtotal	200	196	98.1%	0.3	0.5	0.2	A
WB	Left Turn							
	Through							
	Right Turn							
	Subtotal							
Total		330	323	97.8%	0.4	8.8	1.7	A

Intersection Main Street/Maple Street

Unsignalized

Direction	Movement	Volume (veh/hr)			GEH	Total Delay (sec/veh)		
		Demand	Served	% Served		Average	Std. Dev.	LOS
NB	Left Turn							
	Through	470	336	71.5%	6.7	48.9	7.3	E
	Right Turn							
	Subtotal	470	336	71.5%	6.7	48.9	7.3	E
SB	Left Turn							
	Through	580	262	45.2%	15.5	11.5	2.9	B
	Right Turn							
	Subtotal	580	262	45.2%	15.5	11.5	2.9	B
EB	Left Turn							
	Through							
	Right Turn							
	Subtotal							
WB	Left Turn							
	Through							
	Right Turn	20	12	60.0%	2.0	1208.6	782.8	F
	Subtotal	20	12	60.0%	2.0	1208.6	782.8	F
Total		1070	611	57.1%	15.8	49.4	7.4	E

Intersection Main Street/Beech Street

Unsignalized

Direction	Movement	Volume (veh/hr)			GEH	Total Delay (sec/veh)		
		Demand	Served	% Served		Average	Std. Dev.	LOS
NB	Left Turn	110	82	74.5%	2.9	113.6	38.8	F
	Through	280	212	75.7%	4.3	139.7	60.8	F
	Right Turn							
	Subtotal	390	294	75.4%	5.2	132.1	51.0	F
SB	Left Turn							
	Through	390	179	45.8%	12.5	0.7	0.3	A
	Right Turn	10	5	54.0%	1.7	0.6	1.0	A
	Subtotal	400	184	46.1%	12.6	0.7	0.3	A
EB	Left Turn	90	53	58.4%	4.4	586.2	427.6	F
	Through							
	Right Turn	30	20	68.0%	1.9	517.3	359.4	F
	Subtotal	120	73	60.8%	4.8	565.4	406.8	F
WB	Left Turn							
	Through							
	Right Turn							
	Subtotal							
Total		910	551	60.6%	13.3	136.9	62.5	F

SimTraffic Post-Processor
Average Results from 20 Runs
Volume and Delay by Movement

Caltrain Electrification
2040 No Project Conditions
PM Peak Hour

Intersection Main Street/Middlefield Road

Signalized

Direction	Movement	Volume (veh/hr)			GEH	Total Delay (sec/veh)		
		Demand	Served	% Served		Average	Std. Dev.	LOS
NB	Left Turn	60	38	64.0%	3.1	331.2	78.1	F
	Through	400	288	72.1%	6.0	72.3	3.8	E
	Right Turn	30	22	72.3%	1.6	92.7	33.9	F
	Subtotal	490	349	71.1%	6.9	102.1	14.6	F
SB	Left Turn	130	36	27.6%	10.3	2812.4	291.3	F
	Through	400	150	37.5%	15.1	194.5	37.9	F
	Right Turn	60	21	34.5%	6.2	11.7	7.2	B
	Subtotal	590	206	35.0%	19.2	642.6	85.1	F
EB	Left Turn	90	47	52.7%	5.1	245.1	12.2	F
	Through	1020	546	53.6%	16.9	257.2	7.0	F
	Right Turn	130	76	58.2%	5.4	259.4	10.9	F
	Subtotal	1240	669	54.0%	18.5	256.6	6.7	F
WB	Left Turn	50	25	49.0%	4.2	19.0	6.6	B
	Through	860	387	45.0%	18.9	12.7	1.0	B
	Right Turn	110	52	47.0%	6.5	0.4	0.1	A
	Subtotal	1020	463	45.4%	20.4	11.6	0.7	B
Total		3340	1688	50.5%	33.0	203.5	5.6	F

SimTraffic Post-Processor
Average Results from 20 Runs
Volume and Delay by Movement

Caltrain Electrification
2040 No Project Conditions
PM Peak Hour

Intersection Fair Oaks Lane/Middlefield Road

Unsignalized

Direction	Movement	Volume (veh/hr)			GEH	Total Delay (sec/veh)		
		Demand	Served	% Served		Average	Std. Dev.	LOS
NB	Left Turn	30	22	74.3%	1.5	1139.2	381.7	F
	Through	20	13	65.0%	1.7	1147.0	408.6	F
	Right Turn	130	97	74.3%	3.1	933.2	355.3	F
	Subtotal	180	132	73.3%	3.9	989.1	365.4	F
SB	Left Turn	10	10	101.0%	0.0	341.1	169.5	F
	Through	20	18	92.0%	0.4	361.8	122.6	F
	Right Turn	10	10	103.0%	0.1	269.5	143.6	F
	Subtotal	40	39	97.0%	0.2	338.0	131.6	F
EB	Left Turn	20	17	86.5%	0.6	10.9	2.0	B
	Through	700	699	99.8%	0.1	5.7	0.7	A
	Right Turn	140	138	98.2%	0.2	4.1	0.6	A
	Subtotal	860	853	99.2%	0.2	5.5	0.7	A
WB	Left Turn	190	151	79.6%	3.0	23.1	2.3	C
	Through	1060	906	85.5%	4.9	6.3	0.9	A
	Right Turn	20	14	72.0%	1.4	5.2	1.1	A
	Subtotal	1270	1072	84.4%	5.8	8.7	1.0	A
Total		2350	2096	89.2%	5.4	73.2	20.4	F

Intersection Watkins Avenue/Middlefield Road

Unsignalized

Direction	Movement	Volume (veh/hr)			GEH	Total Delay (sec/veh)		
		Demand	Served	% Served		Average	Std. Dev.	LOS
NB	Left Turn	70	54	76.7%	2.1	578.4	391.1	F
	Through							
	Right Turn	160	126	78.7%	2.9	475.5	387.1	F
	Subtotal	230	180	78.1%	3.5	506.3	388.6	F
SB	Left Turn							
	Through							
	Right Turn							
	Subtotal							
EB	Left Turn							
	Through	670	648	96.7%	0.9	5.7	0.4	A
	Right Turn	170	158	93.0%	0.9	4.6	0.4	A
	Subtotal	840	806	95.9%	1.2	5.5	0.4	A
WB	Left Turn	170	147	86.5%	1.8	24.5	4.2	C
	Through	1200	1038	86.5%	4.9	8.5	0.6	A
	Right Turn							
	Subtotal	1370	1185	86.5%	5.2	10.5	1.1	B
Total		2440	2170	88.9%	5.6	47.2	26.7	E

SimTraffic Post-Processor
Average Results from 20 Runs
Volume and Delay by Movement

Caltrain Electrification
2040 No Project Conditions
PM Peak Hour

Intersection

Linden Avenue-Glenwood Avenue/Middlefield Road

Unsignalized

Direction	Movement	Volume (veh/hr)			GEH	Total Delay (sec/veh)		
		Demand	Served	% Served		Average	Std. Dev.	LOS
NB	Left Turn	200	25	12.4%	16.5	3783.4	1075.3	F
	Through	60	8	13.5%	8.9	4009.9	1162.6	F
	Right Turn	260	30	11.4%	19.1	3623.9	1101.0	F
	Subtotal	520	63	12.0%	26.8	3740.5	1063.4	F
SB	Left Turn	20	12	59.5%	2.0	1515.5	703.6	F
	Through	10	6	59.0%	1.5	1328.8	533.4	F
	Right Turn	60	40	67.0%	2.8	1427.7	619.2	F
	Subtotal	90	58	64.4%	3.7	1438.3	623.7	F
EB	Left Turn	50	47	94.8%	0.4	53.7	22.2	F
	Through	650	616	94.8%	1.3	12.3	7.6	B
	Right Turn	130	123	94.3%	0.7	11.9	7.9	B
	Subtotal	830	786	94.7%	1.5	14.7	8.6	B
WB	Left Turn	120	122	101.3%	0.1	17.6	5.4	C
	Through	1110	1098	98.9%	0.4	8.2	2.4	A
	Right Turn	100	103	102.9%	0.3	6.1	1.3	A
	Subtotal	1330	1322	99.4%	0.2	8.9	2.5	A
Total		2770	2229	80.5%	10.8	143.4	11.9	F

SimTraffic Post-Processor
Average Results from 20 Runs
Volume and Delay by Movement

Caltrain Electrification
2040 No Project Conditions
PM Peak Hour

Intersection California Street/Rengstorff Avenue

Signalized

Direction	Movement	Volume (veh/hr)			GEH	Total Delay (sec/veh)		
		Demand	Served	% Served		Average	Std. Dev.	LOS
NB	Left Turn	90	76	84.4%	1.5	70.2	0.0	E
	Through	430	431	100.2%	0.0	45.2	0.0	D
	Right Turn	220	221	100.5%	0.1	41.2	0.0	D
	Subtotal	740	728	98.4%	0.4	46.6	0.0	D
SB	Left Turn	290	169	58.3%	8.0	359.6	0.0	F
	Through	950	588	61.9%	13.1	270.4	0.0	F
	Right Turn	570	397	69.6%	7.9	272.1	0.0	F
	Subtotal	1810	1154	63.8%	17.0	284.0	0.0	F
EB	Left Turn	80	54	67.5%	3.2	156.9	0.0	F
	Through	500	481	96.2%	0.9	122.7	0.0	F
	Right Turn	610	552	90.5%	2.4	152.3	0.0	F
	Subtotal	1190	1087	91.3%	3.1	139.4	0.0	F
WB	Left Turn	420	305	72.6%	6.0	365.1	0.0	F
	Through	500	352	70.4%	7.2	103.2	0.0	F
	Right Turn	420	307	73.1%	5.9	97.4	0.0	F
	Subtotal	1340	964	71.9%	11.1	184.2	0.0	F
Total		5080	3933	77.4%	17.1	175.7	0.0	F

2040 Project



Intersection Pennsylvania Street/22nd Street

Unsignalized

Direction	Movement	Volume (veh/hr)			GEH	Total Delay (sec/veh)		
		Demand	Served	% Served		Average	Std. Dev.	LOS
NB	Left Turn	60	61	101.3%	0.1	14.3	1.1	B
	Through	170	171	100.7%	0.1	14.7	0.8	B
	Right Turn	60	62	103.2%	0.2	12.7	1.2	B
	Subtotal	290	294	101.3%	0.2	14.2	0.8	B
SB	Left Turn	30	30	99.7%	0.0	9.3	1.6	A
	Through	80	83	103.9%	0.3	10.2	0.8	B
	Right Turn	20	22	109.5%	0.4	7.0	1.1	A
	Subtotal	130	135	103.8%	0.4	9.4	0.7	A
EB	Left Turn	10	10	102.0%	0.1	7.6	1.3	A
	Through	20	18	90.5%	0.4	7.9	1.0	A
	Right Turn	70	72	102.1%	0.2	6.1	0.6	A
	Subtotal	100	100	99.8%	0.0	6.6	0.4	A
WB	Left Turn	90	84	93.6%	0.6	9.8	1.5	A
	Through	40	43	106.3%	0.4	9.1	1.3	A
	Right Turn	30	32	107.7%	0.4	7.9	1.3	A
	Subtotal	160	159	99.4%	0.1	9.2	1.1	A
Total		680	688	101.1%	0.3	11.0	0.6	B

Intersection Indiana Street/22nd Street

Unsignalized

Direction	Movement	Volume (veh/hr)			GEH	Total Delay (sec/veh)		
		Demand	Served	% Served		Average	Std. Dev.	LOS
NB	Left Turn	10	10	98.0%	0.1	6.6	1.4	A
	Through	70	73	104.6%	0.4	8.1	0.6	A
	Right Turn	50	50	99.0%	0.1	5.6	0.6	A
	Subtotal	130	133	101.9%	0.2	7.1	0.6	A
SB	Left Turn	10	11	108.0%	0.2	6.3	1.5	A
	Through	20	20	100.5%	0.0	7.1	0.9	A
	Right Turn	10	9	88.0%	0.4	3.8	0.8	A
	Subtotal	40	40	99.3%	0.0	6.2	0.8	A
EB	Left Turn	30	30	98.7%	0.1	5.8	0.7	A
	Through	120	122	101.5%	0.2	6.4	0.5	A
	Right Turn	30	29	97.7%	0.1	4.7	0.5	A
	Subtotal	180	181	100.4%	0.1	6.0	0.4	A
WB	Left Turn	10	9	87.0%	0.4	4.8	0.7	A
	Through	70	70	100.0%	0.0	5.9	0.5	A
	Right Turn	10	10	96.0%	0.1	4.0	0.7	A
	Subtotal	90	88	98.1%	0.2	5.6	0.3	A
Total		440	441	100.3%	0.1	6.3	0.3	A

SimTraffic Post-Processor
Average Results from 20 Runs
Volume and Delay by Movement

Caltrain Electrification
2040 Plus Project Conditions
AM Peak Hour

Intersection

Tunnel Avenue/Blanken Avenue

Unsignalized

Direction	Movement	Volume (veh/hr)			GEH	Total Delay (sec/veh)		
		Demand	Served	% Served		Average	Std. Dev.	LOS
NB	Left Turn	50	43	86.0%	1.0	269.0	31.9	F
	Through	220	194	88.2%	1.8	271.1	36.4	F
	Right Turn	20	19	93.5%	0.3	268.5	39.9	F
	Subtotal	290	256	88.2%	2.1	270.6	35.5	F
SB	Left Turn	100	88	87.5%	1.3	218.3	41.2	F
	Through	180	162	90.1%	1.4	220.3	36.1	F
	Right Turn	10	12	116.0%	0.5	220.3	37.2	F
	Subtotal	290	261	90.1%	1.7	219.7	37.5	F
EB	Left Turn	20	13	62.5%	1.9	285.3	15.0	F
	Through	300	165	55.1%	8.8	282.9	10.1	F
	Right Turn	200	119	59.4%	6.4	279.5	9.1	F
	Subtotal	520	297	57.0%	11.1	281.7	9.5	F
WB	Left Turn	20	12	62.0%	1.9	281.0	22.1	F
	Through	270	189	69.9%	5.4	285.2	18.1	F
	Right Turn	120	87	72.6%	3.2	279.9	16.0	F
	Subtotal	410	288	70.3%	6.5	283.7	16.9	F
Total		1510	1102	73.0%	11.3	265.1	17.5	F

SimTraffic Post-Processor
Average Results from 20 Runs
Volume and Delay by Movement

Caltrain Electrification
2040 Plus Project Conditions
AM Peak Hour

Intersection Dubuque Avenue/Grand Avenue

Signalized

Direction	Movement	Volume (veh/hr)			GEH	Total Delay (sec/veh)		
		Demand	Served	% Served		Average	Std. Dev.	LOS
NB	Left Turn							
	Through							
	Right Turn							
	Subtotal							
SB	Left Turn	40	40	99.3%	0.0	28.9	3.3	C
	Through							
	Right Turn	70	71	101.9%	0.2	9.6	0.5	A
	Subtotal	110	111	100.9%	0.1	16.5	1.4	B
EB	Left Turn	50	47	93.0%	0.5	33.6	2.6	C
	Through	670	659	98.4%	0.4	9.3	0.6	A
	Right Turn							
	Subtotal	720	706	98.0%	0.5	10.9	0.4	B
WB	Left Turn							
	Through	550	541	98.3%	0.4	15.7	1.0	B
	Right Turn	50	49	98.6%	0.1	12.8	2.4	B
	Subtotal	600	590	98.3%	0.4	15.4	0.9	B
Total		1430	1406	98.3%	0.6	13.2	0.5	B

SimTraffic Post-Processor
Average Results from 20 Runs
Volume and Delay by Movement

Caltrain Electrification
2040 Plus Project Conditions
AM Peak Hour

Intersection **Linden Avenue-San Mateo Avenue/San Mateo Avenue** Signalized

Direction	Movement	Volume (veh/hr)			GEH	Total Delay (sec/veh)		
		Demand	Served	% Served		Average	Std. Dev.	LOS
NB	Left Turn							
	Through	360	289	80.3%	3.9	165.8	23.4	F
	Right Turn	340	273	80.2%	3.9	110.7	22.6	F
	Subtotal	700	562	80.2%	5.5	139.1	23.4	F
SB	Left Turn	170	145	85.4%	2.0	108.0	54.3	F
	Through	300	267	89.1%	1.9	7.5	2.4	A
	Right Turn							
	Subtotal	470	412	87.7%	2.7	43.3	21.3	D
EB	Left Turn							
	Through							
	Right Turn							
	Subtotal							
WB	Left Turn	370	367	99.1%	0.2	27.4	6.0	C
	Through							
	Right Turn	100	94	94.3%	0.6	21.3	28.1	C
	Subtotal	470	461	98.0%	0.4	26.2	9.3	C
Total		1640	1435	87.5%	5.2	74.9	10.4	E

Intersection **Herman Street/Scott Street** Unsignalized

Direction	Movement	Volume (veh/hr)			GEH	Total Delay (sec/veh)		
		Demand	Served	% Served		Average	Std. Dev.	LOS
NB	Left Turn	10	12	117.0%	0.5	46.6	18.5	E
	Through	230	235	102.0%	0.3	47.5	22.8	E
	Right Turn	270	282	104.3%	0.7	44.6	24.2	E
	Subtotal	510	528	103.5%	0.8	45.9	23.3	E
SB	Left Turn	70	66	93.7%	0.5	14.3	1.1	B
	Through	190	159	83.4%	2.4	13.7	1.5	B
	Right Turn	10	9	89.0%	0.4	8.4	2.3	A
	Subtotal	270	233	86.3%	2.3	13.7	1.3	B
EB	Left Turn	10	10	98.0%	0.1	7.8	2.0	A
	Through	50	50	100.0%	0.0	10.8	1.5	B
	Right Turn	10	13	134.0%	1.0	4.9	2.0	A
	Subtotal	70	73	104.6%	0.4	9.3	1.3	A
WB	Left Turn	100	105	104.5%	0.4	0.3	0.1	A
	Through	20	20	98.0%	0.1	0.6	0.1	A
	Right Turn	100	96	95.5%	0.5	0.2	0.1	A
	Subtotal	220	220	99.8%	0.0	0.3	0.1	A
Total		1070	1054	98.5%	0.5	26.8	12.0	D

SimTraffic Post-Processor
Average Results from 20 Runs
Volume and Delay by Movement

Caltrain Electrification
2040 Plus Project Conditions
AM Peak Hour

Intersection **Montgomery Avenue/Scott Street**

Unsignalized

Direction	Movement	Volume (veh/hr)			GEH	Total Delay (sec/veh)		
		Demand	Served	% Served		Average	Std. Dev.	LOS
NB	Left Turn	30	30	99.3%	0.0	10.7	2.0	B
	Through	10	13	125.0%	0.7	10.2	3.3	B
	Right Turn	20	19	94.0%	0.3	4.9	1.6	A
	Subtotal	60	61	101.8%	0.1	8.8	1.1	A
SB	Left Turn	10	9	85.0%	0.5	6.8	2.0	A
	Through	10	10	99.0%	0.0	8.5	1.5	A
	Right Turn	20	20	98.0%	0.1	4.1	1.0	A
	Subtotal	40	38	95.0%	0.3	5.9	0.8	A
EB	Left Turn	60	61	101.2%	0.1	2.6	0.2	A
	Through	290	294	101.2%	0.2	1.0	0.1	A
	Right Turn	40	43	107.0%	0.4	0.4	0.2	A
	Subtotal	390	397	101.8%	0.4	1.2	0.1	A
WB	Left Turn	20	19	95.5%	0.2	2.9	0.4	A
	Through	170	169	99.5%	0.1	0.6	0.2	A
	Right Turn	10	11	113.0%	0.4	0.2	0.2	A
	Subtotal	200	200	99.8%	0.0	0.8	0.2	A
Total		690	696	100.8%	0.2	2.0	0.2	A

Intersection **Driveway-Dollar Avenue/Linden Avenue**

Signalized

Direction	Movement	Volume (veh/hr)			GEH	Total Delay (sec/veh)		
		Demand	Served	% Served		Average	Std. Dev.	LOS
NB	Left Turn	130	130	100.0%	0.0	41.8	12.7	D
	Through							
	Right Turn	120	122	101.4%	0.2	39.5	9.4	D
	Subtotal	250	252	100.7%	0.1	40.8	11.0	D
SB	Left Turn	10	11	109.0%	0.3	55.5	10.9	E
	Through							
	Right Turn							
	Subtotal	10	11	109.0%	0.3	55.5	10.9	E
EB	Left Turn							
	Through	340	282	82.9%	3.3	529.2	183.1	F
	Right Turn	140	122	87.1%	1.6	514.7	183.3	F
	Subtotal	480	404	84.1%	3.6	524.7	182.6	F
WB	Left Turn	110	90	82.1%	2.0	8.9	2.5	A
	Through	340	288	84.7%	2.9	10.0	1.9	A
	Right Turn	10	8	82.0%	0.6	1.4	2.2	A
	Subtotal	460	387	84.0%	3.6	9.6	1.3	A
Total		1200	1053	87.8%	4.4	214.3	70.6	F

SimTraffic Post-Processor
Average Results from 20 Runs
Volume and Delay by Movement

Caltrain Electrification
2040 Plus Project Conditions
AM Peak Hour

Intersection

San Mateo Avenue/San Bruno Avenue

Signalized

Direction	Movement	Volume (veh/hr)			GEH	Total Delay (sec/veh)		
		Demand	Served	% Served		Average	Std. Dev.	LOS
NB	Left Turn	70	68	97.0%	0.3	83.7	57.4	F
	Through	200	201	100.7%	0.1	74.2	47.7	E
	Right Turn	160	170	106.4%	0.8	43.5	44.0	D
	Subtotal	430	439	102.2%	0.5	64.0	48.1	E
SB	Left Turn	110	107	97.5%	0.3	39.8	4.3	D
	Through	150	157	104.4%	0.5	33.9	3.4	C
	Right Turn	130	131	100.5%	0.1	27.0	5.4	C
	Subtotal	390	394	101.1%	0.2	33.3	4.0	C
EB	Left Turn	320	183	57.2%	8.6	32.4	4.1	C
	Through	370	218	59.0%	8.8	11.6	1.3	B
	Right Turn	10	6	64.0%	1.3	2.8	3.9	A
	Subtotal	700	408	58.3%	12.4	20.8	2.3	C
WB	Left Turn	320	331	103.4%	0.6	66.6	15.0	E
	Through	570	573	100.5%	0.1	30.6	4.1	C
	Right Turn	140	139	99.3%	0.1	27.1	4.1	C
	Subtotal	1030	1043	101.2%	0.4	41.6	7.7	D
Total		2550	2284	89.6%	5.4	40.7	13.1	D

Intersection El Camino Real/Millbrae Avenue

Signalized

Direction	Movement	Volume (veh/hr)			GEH	Total Delay (sec/veh)		
		Demand	Served	% Served		Average	Std. Dev.	LOS
NB	Left Turn	90	83	92.1%	0.8	120.7	31.0	F
	Through	1330	1344	101.1%	0.4	66.8	10.2	E
	Right Turn	550	551	100.2%	0.0	4.9	0.7	A
	Subtotal	1970	1978	100.4%	0.2	51.9	6.8	D
SB	Left Turn	800	659	82.3%	5.2	195.7	4.3	F
	Through	1120	908	81.0%	6.7	52.4	2.5	D
	Right Turn	40	35	87.3%	0.8	52.5	5.5	D
	Subtotal	1960	1601	81.7%	8.5	111.4	3.8	F
EB	Left Turn	70	61	87.0%	1.1	318.2	71.7	F
	Through	700	638	91.1%	2.4	260.7	67.8	F
	Right Turn	170	152	89.4%	1.4	291.2	69.3	F
	Subtotal	940	851	90.5%	3.0	270.3	68.4	F
WB	Left Turn	640	498	77.8%	6.0	331.4	73.7	F
	Through	240	214	89.2%	1.7	20.7	2.4	C
	Right Turn	530	436	82.2%	4.3	13.5	2.0	B
	Subtotal	1410	1147	81.4%	7.3	152.6	32.0	F
Total		6280	5577	88.8%	9.1	123.1	11.7	F

Intersection Rollins Road/Millbrae Avenue

Signalized

Direction	Movement	Volume (veh/hr)			GEH	Total Delay (sec/veh)		
		Demand	Served	% Served		Average	Std. Dev.	LOS
NB	Left Turn	160	94	58.6%	5.9	298.2	261.6	F
	Through	320	201	62.7%	7.4	250.7	22.9	F
	Right Turn	360	237	65.9%	7.1	180.9	17.4	F
	Subtotal	840	531	63.3%	11.8	225.0	34.9	F
SB	Left Turn	220	213	97.0%	0.4	56.0	4.0	E
	Through	90	89	98.8%	0.1	55.8	3.4	E
	Right Turn	210	201	95.8%	0.6	137.4	115.4	F
	Subtotal	520	504	96.8%	0.7	89.3	45.1	F
EB	Left Turn	330	290	88.0%	2.2	78.5	10.5	E
	Through	1410	1288	91.3%	3.3	32.9	4.8	C
	Right Turn	310	277	89.3%	1.9	20.7	3.7	C
	Subtotal	2050	1855	90.5%	4.4	38.2	5.1	D
WB	Left Turn	720	615	85.5%	4.1	181.7	12.1	F
	Through	1040	878	84.4%	5.2	65.7	11.6	E
	Right Turn	520	452	86.9%	3.1	9.6	2.0	A
	Subtotal	2280	1946	85.3%	7.3	89.5	3.4	F
Total		5690	4836	85.0%	11.8	84.4	8.7	F

Intersection **California Drive/Oak Grove Avenue**

Signalized

Direction	Movement	Volume (veh/hr)			GEH	Total Delay (sec/veh)		
		Demand	Served	% Served		Average	Std. Dev.	LOS
NB	Left Turn	60	56	93.0%	0.6	71.7	5.0	E
	Through	540	510	94.4%	1.3	33.4	1.7	C
	Right Turn	260	240	92.2%	1.3	13.5	2.1	B
	Subtotal	860	805	93.6%	1.9	30.2	1.8	C
SB	Left Turn	140	141	101.0%	0.1	80.2	8.4	F
	Through	820	815	99.4%	0.2	39.1	6.0	D
	Right Turn	60	56	93.7%	0.5	16.9	5.6	B
	Subtotal	1020	1013	99.3%	0.2	43.7	5.8	D
EB	Left Turn	110	85	77.3%	2.5	345.2	37.3	F
	Through	420	328	78.0%	4.8	351.3	38.3	F
	Right Turn	40	33	82.0%	1.2	340.7	36.8	F
	Subtotal	570	446	78.2%	5.5	349.3	37.0	F
WB	Left Turn	160	70	44.0%	8.3	37.2	2.8	D
	Through	130	62	47.6%	7.0	36.5	2.7	D
	Right Turn	300	133	44.4%	11.3	16.1	2.4	B
	Subtotal	590	265	45.0%	15.7	26.4	2.4	C
Total		3040	2529	83.2%	9.7	91.2	5.1	F

Intersection **Carolan Avenue/Oak Grove Avenue**

Unsignalized

Direction	Movement	Volume (veh/hr)			GEH	Total Delay (sec/veh)		
		Demand	Served	% Served		Average	Std. Dev.	LOS
NB	Left Turn	150	63	41.7%	8.5	804.4	87.9	F
	Through	120	53	44.0%	7.2	799.4	68.4	F
	Right Turn	40	15	38.3%	4.7	752.0	108.9	F
	Subtotal	310	131	42.2%	12.1	797.6	74.8	F
SB	Left Turn	10	4	39.0%	2.3	356.5	64.1	F
	Through	450	217	48.2%	12.8	336.3	33.6	F
	Right Turn	170	86	50.6%	7.4	204.7	37.0	F
	Subtotal	630	307	48.7%	14.9	301.5	25.8	F
EB	Left Turn	460	389	84.6%	3.4	0.5	0.1	A
	Through	270	247	91.6%	1.4	1.1	0.1	A
	Right Turn	90	84	93.3%	0.6	0.2	0.1	A
	Subtotal	820	720	87.8%	3.6	0.7	0.0	A
WB	Left Turn	20	8	40.5%	3.2	473.4	47.1	F
	Through	270	109	40.3%	11.7	497.2	29.1	F
	Right Turn	130	55	42.2%	7.8	477.7	40.3	F
	Subtotal	420	172	40.9%	14.4	489.7	30.4	F
Total		2180	1329	61.0%	20.3	210.5	5.7	F

Intersection **California Drive/North Lane**

Unsignalized

Direction	Movement	Volume (veh/hr)			GEH	Total Delay (sec/veh)		
		Demand	Served	% Served		Average	Std. Dev.	LOS
NB	Left Turn							
	Through	930	926	99.6%	0.1	1.7	0.1	A
	Right Turn	310	304	98.1%	0.3	3.4	0.5	A
	Subtotal	1240	1230	99.2%	0.3	2.1	0.2	A
SB	Left Turn	210	188	89.6%	1.5	38.8	10.0	E
	Through	210	184	87.8%	1.8	1.6	0.2	A
	Right Turn							
	Subtotal	420	373	88.7%	2.4	20.4	5.2	C
EB	Left Turn							
	Through							
	Right Turn							
	Subtotal							
WB	Left Turn	80	52	64.6%	3.5	54.6	13.8	F
	Through							
	Right Turn	210	143	68.1%	5.0	5.9	0.7	A
	Subtotal	290	195	67.2%	6.1	18.7	3.8	C
Total		1950	1798	92.2%	3.5	7.7	1.3	A

Intersection **Carolan Avenue/North Lane**

Unsignalized

Direction	Movement	Volume (veh/hr)			GEH	Total Delay (sec/veh)		
		Demand	Served	% Served		Average	Std. Dev.	LOS
NB	Left Turn	140	114	81.1%	2.4	198.0	26.6	F
	Through	240	195	81.4%	3.0	106.7	8.5	F
	Right Turn	20	17	86.0%	0.6	106.0	43.9	F
	Subtotal	400	326	81.5%	3.9	138.5	15.2	F
SB	Left Turn	10	5	52.0%	1.7	80.6	38.6	F
	Through	210	112	53.2%	7.7	89.4	49.9	F
	Right Turn	150	83	55.1%	6.2	68.8	52.4	F
	Subtotal	370	200	54.0%	10.1	81.2	49.2	F
EB	Left Turn	340	325	95.4%	0.9	1.6	0.2	A
	Through	20	23	115.5%	0.7	1.3	0.3	A
	Right Turn	160	150	94.0%	0.8	0.9	0.2	A
	Subtotal	520	498	95.8%	1.0	1.4	0.1	A
WB	Left Turn							
	Through							
	Right Turn							
	Subtotal							
Total		1290	1024	79.4%	7.8	60.3	9.1	F

Intersection Anita Road/Peninsula Avenue

Unsignalized

Direction	Movement	Volume (veh/hr)			GEH	Total Delay (sec/veh)		
		Demand	Served	% Served		Average	Std. Dev.	LOS
NB	Left Turn							
	Through							
	Right Turn							
	Subtotal							
SB	Left Turn	30	34	111.7%	0.6	27.4	18.0	D
	Through							
	Right Turn	30	32	107.0%	0.4	36.3	34.9	E
	Subtotal	60	66	109.3%	0.7	31.9	24.8	D
EB	Left Turn	50	46	91.6%	0.6	9.2	2.8	A
	Through	630	641	101.7%	0.4	0.6	0.2	A
	Right Turn							
	Subtotal	680	687	101.0%	0.2	1.2	0.4	A
WB	Left Turn							
	Through	590	607	102.9%	0.7	7.8	3.5	A
	Right Turn	70	66	94.6%	0.5	5.3	2.0	A
	Subtotal	660	673	102.0%	0.5	7.5	3.3	A
Total		1400	1425	101.8%	0.7	5.5	2.4	A

Intersection Woodside Way/Villa Terrace

Unsignalized

Direction	Movement	Volume (veh/hr)			GEH	Total Delay (sec/veh)		
		Demand	Served	% Served		Average	Std. Dev.	LOS
NB	Left Turn	10	10	100.0%	0.0	5.2	0.6	A
	Through	30	26	88.0%	0.7	5.8	0.3	A
	Right Turn	10	11	105.0%	0.2	2.8	0.6	A
	Subtotal	50	47	93.8%	0.4	5.0	0.3	A
SB	Left Turn	10	9	89.0%	0.4	6.0	0.8	A
	Through	20	24	121.0%	0.9	6.4	0.7	A
	Right Turn	60	61	101.0%	0.1	3.3	0.3	A
	Subtotal	90	94	104.1%	0.4	4.4	0.3	A
EB	Left Turn	60	58	97.0%	0.2	1.9	0.1	A
	Through	20	21	105.5%	0.2	0.6	0.1	A
	Right Turn	10	6	63.0%	1.3	0.4	0.5	A
	Subtotal	90	86	95.1%	0.5	1.5	0.1	A
WB	Left Turn	10	8	79.0%	0.7	1.8	0.2	A
	Through	20	21	103.5%	0.2	0.5	0.3	A
	Right Turn	20	23	113.0%	0.6	0.3	0.1	A
	Subtotal	50	51	102.4%	0.2	0.6	0.2	A
Total		280	277	99.1%	0.2	2.9	0.2	A

Intersection

N. San Mateo Drive/Villa Terrace

Unsignalized

Direction	Movement	Volume (veh/hr)			GEH	Total Delay (sec/veh)		
		Demand	Served	% Served		Average	Std. Dev.	LOS
NB	Left Turn	20	20	99.5%	0.0	4.7	1.2	A
	Through	480	475	99.0%	0.2	0.5	0.0	A
	Right Turn	40	37	91.8%	0.5	0.6	0.1	A
	Subtotal	540	532	98.5%	0.3	0.7	0.1	A
SB	Left Turn	20	19	95.5%	0.2	5.0	0.6	A
	Through	560	572	102.1%	0.5	2.7	0.1	A
	Right Turn	20	18	90.0%	0.5	2.9	0.4	A
	Subtotal	600	609	101.5%	0.4	2.7	0.1	A
EB	Left Turn	10	10	99.0%	0.0	11.2	3.1	B
	Through	30	30	98.3%	0.1	14.3	1.7	B
	Right Turn	20	21	102.5%	0.1	5.5	1.5	A
	Subtotal	60	60	99.8%	0.0	10.8	1.2	B
WB	Left Turn	40	40	100.0%	0.0	12.5	2.4	B
	Through	30	28	94.0%	0.3	15.4	2.6	C
	Right Turn	20	24	119.0%	0.8	6.5	1.4	A
	Subtotal	90	92	102.2%	0.2	11.8	1.9	B
Total		1290	1293	100.2%	0.1	2.9	0.2	A

Intersection

Arundel Road/Peninsula Avenue

Unsignalized

Direction	Movement	Volume (veh/hr)			GEH	Total Delay (sec/veh)		
		Demand	Served	% Served		Average	Std. Dev.	LOS
NB	Left Turn	30	27	91.3%	0.5	39.3	15.3	E
	Through	10	12	116.0%	0.5	25.7	10.0	D
	Right Turn	70	72	102.4%	0.2	18.3	12.1	C
	Subtotal	110	111	100.6%	0.1	24.3	12.7	C
SB	Left Turn	20	21	104.0%	0.2	19.4	5.0	C
	Through	10	11	111.0%	0.3	19.0	7.2	C
	Right Turn	10	8	80.0%	0.7	11.2	3.7	B
	Subtotal	40	40	99.8%	0.0	17.9	2.8	C
EB	Left Turn	10	9	94.0%	0.2	5.0	1.0	A
	Through	610	629	103.1%	0.8	0.7	0.1	A
	Right Turn	40	40	100.3%	0.0	0.6	0.2	A
	Subtotal	660	678	102.8%	0.7	0.7	0.1	A
WB	Left Turn	40	41	102.5%	0.2	7.6	1.6	A
	Through	620	617	99.5%	0.1	4.3	2.0	A
	Right Turn	30	30	101.3%	0.1	3.3	2.5	A
	Subtotal	690	688	99.7%	0.1	4.5	2.0	A
Total		1500	1517	101.1%	0.4	4.6	1.6	A

Intersection

Railroad Ave/1st Ave

Unsignalized

Direction	Movement	Volume (veh/hr)			GEH	Total Delay (sec/veh)		
		Demand	Served	% Served		Average	Std. Dev.	LOS
NB	Left Turn	10	9	92.0%	0.3	24.4	19.6	C
	Through	10	12	119.0%	0.6	12.1	6.9	B
	Right Turn	10	11	111.0%	0.3	8.7	3.6	A
	Subtotal	30	32	107.3%	0.4	15.0	9.2	B
SB	Left Turn							
	Through							
	Right Turn							
	Subtotal							
EB	Left Turn	20	18	88.5%	0.5	4.0	0.8	A
	Through	100	93	93.3%	0.7	0.5	0.1	A
	Right Turn							
	Subtotal	120	111	92.5%	0.8	1.1	0.2	A
WB	Left Turn							
	Through	330	333	100.8%	0.1	10.8	3.7	B
	Right Turn	20	19	97.0%	0.1	7.8	4.0	A
	Subtotal	350	352	100.6%	0.1	10.6	3.5	B
Total		500	495	99.1%	0.2	8.8	3.1	A

Intersection

S. B. St/1st Ave

Signalized

Direction	Movement	Volume (veh/hr)			GEH	Total Delay (sec/veh)		
		Demand	Served	% Served		Average	Std. Dev.	LOS
NB	Left Turn	40	41	102.5%	0.2	38.0	10.1	D
	Through	340	341	100.3%	0.1	28.2	7.6	C
	Right Turn	20	22	110.5%	0.5	24.6	11.7	C
	Subtotal	400	404	101.0%	0.2	29.0	7.9	C
SB	Left Turn	50	34	68.0%	2.5	33.2	6.2	C
	Through	490	331	67.5%	7.9	19.7	1.6	B
	Right Turn	10	7	70.0%	1.0	22.1	7.9	C
	Subtotal	550	372	67.6%	8.3	21.0	1.9	C
EB	Left Turn	10	11	105.0%	0.2	28.6	11.3	C
	Through	100	100	99.5%	0.1	17.6	3.5	B
	Right Turn	50	50	99.8%	0.0	11.2	3.0	B
	Subtotal	160	160	99.9%	0.0	16.3	3.5	B
WB	Left Turn	20	22	107.5%	0.3	15.1	3.9	B
	Through	120	121	100.8%	0.1	12.0	1.5	B
	Right Turn	130	134	103.2%	0.4	9.1	1.3	A
	Subtotal	270	277	102.4%	0.4	10.8	1.2	B
Total		1380	1212	87.8%	4.7	20.7	3.4	C

Intersection

Transit Center Way/1st St

Unsignalized

Direction	Movement	Volume (veh/hr)			GEH	Total Delay (sec/veh)		
		Demand	Served	% Served		Average	Std. Dev.	LOS
NB	Left Turn	20	20	99.0%	0.0	10.6	4.5	B
	Through	10	11	110.0%	0.3	10.1	5.3	B
	Right Turn	10	10	100.0%	0.0	5.5	4.1	A
	Subtotal	40	41	102.0%	0.1	9.2	3.5	A
SB	Left Turn							
	Through							
	Right Turn							
	Subtotal							
EB	Left Turn	40	38	95.0%	0.3	8.5	2.3	A
	Through	110	103	93.2%	0.7	4.2	1.4	A
	Right Turn	20	18	90.0%	0.5	2.9	1.3	A
	Subtotal	170	159	93.2%	0.9	5.1	1.5	A
WB	Left Turn							
	Through	250	256	102.4%	0.4	2.0	0.4	A
	Right Turn	90	87	96.7%	0.3	0.6	0.2	A
	Subtotal	340	343	100.9%	0.2	1.6	0.4	A
Total		550	542	98.6%	0.3	3.2	0.8	A

SimTraffic Post-Processor
Average Results from 10 Runs
Volume and Delay by Movement

Caltrain Electrification
2040 Plus Project Conditions
AM Peak Hour

Intersection **Railroad Avenue/9th Avenue**

Unsignalized

Direction	Movement	Volume (veh/hr)			GEH	Total Delay (sec/veh)		
		Demand	Served	% Served		Average	Std. Dev.	LOS
NB	Left Turn	40	39	96.8%	0.2	431.1	320.5	F
	Through							
	Right Turn	20	18	88.0%	0.6	379.9	318.9	F
	Subtotal	60	56	93.8%	0.5	415.6	316.3	F
SB	Left Turn							
	Through							
	Right Turn							
	Subtotal							
EB	Left Turn							
	Through	610	597	97.8%	0.5	4.0	0.9	A
	Right Turn	130	125	96.2%	0.4	2.2	0.7	A
	Subtotal	740	722	97.5%	0.7	3.7	0.8	A
WB	Left Turn	10	9	89.0%	0.4	21.5	7.1	C
	Through	690	687	99.6%	0.1	12.4	3.8	B
	Right Turn							
	Subtotal	700	696	99.4%	0.2	12.6	3.8	B
Total		1500	1474	98.3%	0.7	22.4	9.8	C

Intersection **S B Street/9th Avenue**

Signalized

Direction	Movement	Volume (veh/hr)			GEH	Total Delay (sec/veh)		
		Demand	Served	% Served		Average	Std. Dev.	LOS
NB	Left Turn	10	9	86.0%	0.5	35.9	11.0	D
	Through	110	114	103.7%	0.4	24.0	3.0	C
	Right Turn	160	157	98.3%	0.2	18.0	3.4	B
	Subtotal	280	280	100.0%	0.0	21.0	2.9	C
SB	Left Turn	80	80	99.9%	0.0	54.1	13.3	D
	Through	120	137	114.0%	1.5	25.6	6.6	C
	Right Turn	150	149	99.5%	0.1	20.9	7.2	C
	Subtotal	350	366	104.5%	0.8	29.9	7.6	C
EB	Left Turn	40	37	93.3%	0.4	186.9	77.3	F
	Through	500	481	96.1%	0.9	181.2	76.5	F
	Right Turn	10	11	113.0%	0.4	180.5	84.7	F
	Subtotal	550	529	96.2%	0.9	181.7	76.5	F
WB	Left Turn	140	131	93.3%	0.8	40.6	5.5	D
	Through	490	492	100.4%	0.1	18.4	2.3	B
	Right Turn	100	101	100.8%	0.1	14.8	3.7	B
	Subtotal	730	724	99.1%	0.2	21.9	2.6	C
Total		1910	1899	99.4%	0.3	67.7	20.7	E

SimTraffic Post-Processor
Average Results from 10 Runs
Volume and Delay by Movement

Caltrain Electrification
2040 Plus Project Conditions
AM Peak Hour

Intersection

Concar Drive/SR 92 WB Ramps

Signalized

Direction	Movement	Volume (veh/hr)			GEH	Total Delay (sec/veh)		
		Demand	Served	% Served		Average	Std. Dev.	LOS
NB	Left Turn	190	195	102.5%	0.3	26.8	2.9	C
	Through	70	73	103.9%	0.3	23.5	2.9	C
	Right Turn							
	Subtotal	260	267	102.8%	0.5	25.9	2.8	C
SB	Left Turn	10	10	97.0%	0.1	53.5	83.6	D
	Through	10	10	96.0%	0.1	14.9	12.4	B
	Right Turn	10	11	113.0%	0.4	10.1	9.5	B
	Subtotal	30	31	102.0%	0.1	21.0	17.2	C
EB	Left Turn	10	10	100.0%	0.0	264.4	252.7	F
	Through	70	64	90.7%	0.8	236.4	160.7	F
	Right Turn	90	88	98.0%	0.2	193.8	147.1	F
	Subtotal	170	162	95.1%	0.6	214.1	157.8	F
WB	Left Turn	1020	835	81.9%	6.1	6.5	0.7	A
	Through	30	27	89.7%	0.6	7.9	2.2	A
	Right Turn	20	21	103.5%	0.2	1.6	0.7	A
	Subtotal	1070	883	82.5%	6.0	6.4	0.7	A
Total		1530	1342	87.7%	5.0	35.3	19.1	D

SimTraffic Post-Processor
Average Results from 20 Runs
Volume and Delay by Movement

Caltrain Electrification
2040 Plus Project Conditions
AM Peak Hour

Intersection

Delaware Ave/25th Ave

Signalized

Direction	Movement	Volume (veh/hr)			GEH	Total Delay (sec/veh)		
		Demand	Served	% Served		Average	Std. Dev.	LOS
NB	Left Turn	30	29	96.3%	0.2	82.5	96.4	F
	Through	20	18	87.5%	0.6	13.0	4.5	B
	Right Turn							
	Subtotal	50	46	92.8%	0.5	57.9	66.2	E
SB	Left Turn							
	Through	40	41	101.5%	0.1	13.4	2.6	B
	Right Turn	800	793	99.2%	0.2	19.8	17.8	B
	Subtotal	840	834	99.3%	0.2	19.5	17.0	B
EB	Left Turn	720	659	91.5%	2.3	31.8	3.9	C
	Through							
	Right Turn	60	53	87.5%	1.0	11.6	3.1	B
	Subtotal	780	711	91.2%	2.5	30.3	3.8	C
WB	Left Turn							
	Through							
	Right Turn							
	Subtotal							
Total		1670	1592	95.3%	1.9	25.6	12.2	C

Intersection

El Camino Real/25th Ave

Signalized

Direction	Movement	Volume (veh/hr)			GEH	Total Delay (sec/veh)		
		Demand	Served	% Served		Average	Std. Dev.	LOS
NB	Left Turn	60	56	93.7%	0.5	56.0	5.2	E
	Through	1570	1577	100.4%	0.2	35.0	8.1	C
	Right Turn	330	328	99.4%	0.1	42.9	9.7	D
	Subtotal	1960	1961	100.1%	0.0	36.9	8.2	D
SB	Left Turn	90	83	91.7%	0.8	56.2	2.7	E
	Through	1730	1701	98.3%	0.7	28.0	2.2	C
	Right Turn	60	63	105.5%	0.4	32.6	4.6	C
	Subtotal	1880	1847	98.2%	0.8	29.4	2.1	C
EB	Left Turn	150	105	69.8%	4.0	475.9	94.1	F
	Through	170	112	65.9%	4.9	626.3	107.3	F
	Right Turn	60	38	64.0%	3.1	475.5	92.8	F
	Subtotal	380	255	67.1%	7.0	542.6	99.1	F
WB	Left Turn	600	584	97.3%	0.7	57.9	4.3	E
	Through	120	126	104.8%	0.5	63.3	2.9	E
	Right Turn	110	115	104.4%	0.5	29.8	5.7	C
	Subtotal	830	824	99.3%	0.2	54.8	4.0	D
Total		5050	4888	96.8%	2.3	63.4	4.2	E

SimTraffic Post-Processor
Average Results from 20 Runs
Volume and Delay by Movement

Caltrain Electrification
2040 Plus Project Conditions
AM Peak Hour

Intersection El Camino Real/31st Street

Signalized

Direction	Movement	Volume (veh/hr)			GEH	Total Delay (sec/veh)		
		Demand	Served	% Served		Average	Std. Dev.	LOS
NB	Left Turn	80	78	97.0%	0.3	104.1	25.5	F
	Through	1940	1948	100.4%	0.2	27.9	2.0	C
	Right Turn	160	156	97.4%	0.3	3.9	0.6	A
	Subtotal	2180	2181	100.1%	0.0	28.9	2.3	C
SB	Left Turn	80	79	98.8%	0.1	62.1	12.1	E
	Through	2030	2076	102.3%	1.0	36.9	2.7	D
	Right Turn	120	129	107.1%	0.8	32.8	5.6	C
	Subtotal	2230	2283	102.4%	1.1	37.5	2.9	D
EB	Left Turn	190	190	99.8%	0.0	43.4	2.4	D
	Through	60	58	96.3%	0.3	47.2	4.7	D
	Right Turn	240	242	101.0%	0.1	13.3	1.0	B
	Subtotal	490	490	100.0%	0.0	28.9	1.5	C
WB	Left Turn	20	20	98.0%	0.1	27.3	6.7	C
	Through	80	81	101.3%	0.1	30.5	2.0	C
	Right Turn	80	74	93.0%	0.6	14.3	1.9	B
	Subtotal	180	175	97.2%	0.4	23.3	1.9	C
Total		5080	5129	101.0%	0.7	32.6	2.0	C

Intersection El Camino Real/Hillsdale Blvd

Signalized

Direction	Movement	Volume (veh/hr)			GEH	Total Delay (sec/veh)		
		Demand	Served	% Served		Average	Std. Dev.	LOS
NB	Left Turn							
	Through							
	Right Turn							
	Subtotal							
SB	Left Turn	360	359	99.7%	0.1	41.1	1.9	D
	Through							
	Right Turn	280	284	101.5%	0.3	15.5	2.4	B
	Subtotal	640	643	100.5%	0.1	29.8	1.3	C
EB	Left Turn							
	Through	700	585	83.6%	4.5	113.8	4.7	F
	Right Turn	50	43	86.0%	1.0	66.7	8.5	E
	Subtotal	750	628	83.7%	4.6	110.6	4.6	F
WB	Left Turn	260	257	98.7%	0.2	3.6	0.7	A
	Through	850	855	100.6%	0.2	5.1	0.4	A
	Right Turn							
	Subtotal	1110	1111	100.1%	0.0	4.7	0.4	A
Total		2500	2382	95.3%	2.4	59.0	1.2	E

SimTraffic Post-Processor
Average Results from 20 Runs
Volume and Delay by Movement

Caltrain Electrification
2040 Plus Project Conditions
AM Peak Hour

Intersection **Curtiss Street/Hillsdale Blvd**

Signalized

Direction	Movement	Volume (veh/hr)			GEH	Total Delay (sec/veh)		
		Demand	Served	% Served		Average	Std. Dev.	LOS
NB	Left Turn	140	136	96.9%	0.4	52.1	8.1	D
	Through	10	9	92.0%	0.3	51.7	12.6	D
	Right Turn	200	191	95.3%	0.7	32.9	5.7	C
	Subtotal	350	335	95.8%	0.8	41.2	7.4	D
SB	Left Turn	40	40	99.8%	0.0	41.4	3.3	D
	Through	10	10	100.0%	0.0	30.2	6.7	C
	Right Turn	40	40	101.0%	0.1	28.7	5.2	C
	Subtotal	90	90	100.3%	0.0	34.5	2.9	C
EB	Left Turn	10	8	82.0%	0.6	59.5	22.8	E
	Through	1310	1251	95.5%	1.7	16.3	3.0	B
	Right Turn	130	122	93.9%	0.7	15.3	3.0	B
	Subtotal	1450	1381	95.2%	1.8	16.4	3.1	B
WB	Left Turn	30	29	97.3%	0.1	49.0	13.1	D
	Through	1390	1406	101.2%	0.4	22.6	5.8	C
	Right Turn	30	32	106.3%	0.3	19.5	6.1	B
	Subtotal	1450	1468	101.2%	0.5	23.1	6.0	C
Total		3340	3274	98.0%	1.1	22.5	3.7	C

Intersection

El Camino Real/Ralston Avenue

Signalized

Direction	Movement	Volume (veh/hr)			GEH	Total Delay (sec/veh)		
		Demand	Served	% Served		Average	Std. Dev.	LOS
NB	Left Turn	170	75	43.8%	8.6	1399.5	67.5	F
	Through	960	543	56.6%	15.2	142.8	19.1	F
	Right Turn	190	103	54.1%	7.2	24.9	4.5	C
	Subtotal	1320	720	54.6%	18.8	257.9	21.2	F
SB	Left Turn	410	150	36.7%	15.5	801.1	19.0	F
	Through	1040	403	38.8%	23.7	66.8	3.5	E
	Right Turn	80	33	41.1%	6.3	12.0	2.6	B
	Subtotal	1530	586	38.3%	29.0	254.0	23.4	F
EB	Left Turn	210	184	87.7%	1.8	351.6	32.5	F
	Through	930	786	84.5%	4.9	374.5	33.9	F
	Right Turn	60	56	93.0%	0.6	389.1	38.2	F
	Subtotal	1200	1026	85.5%	5.2	371.2	33.7	F
WB	Left Turn	170	167	98.0%	0.3	32.4	2.2	C
	Through	690	687	99.6%	0.1	38.7	1.3	D
	Right Turn	230	229	99.6%	0.1	11.4	1.5	B
	Subtotal	1090	1083	99.3%	0.2	31.9	1.2	C
Total		5140	3416	66.5%	26.4	218.7	10.2	F

SimTraffic Post-Processor
Average Results from 10 Runs
Volume and Delay by Movement

Caltrain Electrification
2040 Plus Project Conditions
AM Peak Hour

Intersection

El Camino Real/San Carlos Avenue-Caltrain Station

Signalized

Direction	Movement	Volume (veh/hr)			GEH	Total Delay (sec/veh)		
		Demand	Served	% Served		Average	Std. Dev.	LOS
NB	Left Turn	90	91	101.0%	0.1	49.9	2.7	D
	Through	760	759	99.9%	0.0	19.0	0.9	B
	Right Turn	20	22	108.0%	0.4	16.5	3.8	B
	Subtotal	870	872	100.2%	0.1	22.2	0.4	C
SB	Left Turn	30	28	94.0%	0.3	50.5	10.1	D
	Through	870	879	101.0%	0.3	20.9	0.9	C
	Right Turn	290	298	102.6%	0.4	9.1	0.7	A
	Subtotal	1190	1204	101.2%	0.4	18.6	0.9	B
EB	Left Turn	500	496	99.3%	0.2	26.2	1.5	C
	Through	40	50	124.0%	1.4	29.8	2.8	C
	Right Turn	220	220	100.0%	0.0	23.4	2.3	C
	Subtotal	760	766	100.8%	0.2	25.6	1.6	C
WB	Left Turn	50	50	99.4%	0.0	102.9	24.4	F
	Through	50	48	95.4%	0.3	89.7	32.4	F
	Right Turn	50	52	103.8%	0.3	47.2	21.8	D
	Subtotal	150	149	99.5%	0.1	79.3	26.8	E
Total		2970	2992	100.7%	0.4	24.5	1.6	C

Intersection

California/Broadway

Unsignalized

Direction	Movement	Volume (veh/hr)			GEH	Total Delay (sec/veh)		
		Demand	Served	% Served		Average	Std. Dev.	LOS
NB	Left Turn	40	6	15.8%	7.0	1371.0	257.1	F
	Through	60	9	14.7%	8.7	1444.0	220.6	F
	Right Turn	330	41	12.5%	21.2	1371.1	190.6	F
	Subtotal	430	57	13.1%	23.9	1377.1	170.8	F
SB	Left Turn	150	27	18.3%	13.0	610.9	117.4	F
	Through	50	8	15.2%	7.9	610.1	184.2	F
	Right Turn	20	4	19.5%	4.7	444.4	201.8	F
	Subtotal	220	39	17.7%	15.9	596.9	105.5	F
EB	Left Turn	30	8	27.0%	5.0	117.2	41.3	F
	Through	1040	283	27.2%	29.4	98.0	10.1	F
	Right Turn	190	53	28.1%	12.4	91.4	23.1	F
	Subtotal	1260	344	27.3%	32.3	97.6	12.4	F
WB	Left Turn	170	53	31.1%	11.1	23.2	3.5	C
	Through	1090	314	28.8%	29.3	16.4	3.6	C
	Right Turn	140	42	30.1%	10.2	0.5	0.2	A
	Subtotal	1400	409	29.2%	32.9	15.7	3.0	C
Total		3310	849	25.7%	54.0	164.7	11.8	F

Intersection

Arguello Street/Brewster Ave

Signalized

Direction	Movement	Volume (veh/hr)			GEH	Total Delay (sec/veh)		
		Demand	Served	% Served		Average	Std. Dev.	LOS
NB	Left Turn	60	14	23.3%	7.6	104.5	30.6	F
	Through	370	84	22.8%	19.0	27.6	3.5	C
	Right Turn	50	13	25.2%	6.7	4.4	1.0	A
	Subtotal	480	111	23.1%	21.5	34.5	5.4	C
SB	Left Turn	40	22	54.5%	3.3	293.0	51.3	F
	Through	610	287	47.0%	15.3	282.8	30.1	F
	Right Turn	150	74	49.4%	7.2	275.3	33.5	F
	Subtotal	800	383	47.9%	17.2	281.8	30.5	F
EB	Left Turn	140	136	96.9%	0.4	6.1	1.0	A
	Through	530	533	100.5%	0.1	4.9	0.4	A
	Right Turn	70	69	99.0%	0.1	12.0	4.5	B
	Subtotal	740	738	99.7%	0.1	5.8	0.5	A
WB	Left Turn	50	49	97.0%	0.2	53.5	19.0	D
	Through	140	144	102.9%	0.3	16.8	2.6	B
	Right Turn	20	20	100.0%	0.0	11.0	6.2	B
	Subtotal	210	213	101.2%	0.2	24.5	5.4	C
Total		2230	1444	64.7%	18.3	83.4	5.3	F

Intersection

El Camino Real/Broadway

Signalized

Direction	Movement	Volume (veh/hr)			GEH	Total Delay (sec/veh)		
		Demand	Served	% Served		Average	Std. Dev.	LOS
NB	Left Turn	210	150	71.3%	4.5	175.3	16.7	F
	Through	1200	886	73.8%	9.7	133.1	9.1	F
	Right Turn	110	78	71.0%	3.3	107.1	20.9	F
	Subtotal	1520	1114	73.3%	11.2	136.9	7.4	F
SB	Left Turn	160	129	80.4%	2.6	147.5	45.5	F
	Through	1190	984	82.7%	6.2	65.5	3.5	E
	Right Turn	10	9	89.0%	0.4	30.6	22.4	C
	Subtotal	1360	1122	82.5%	6.8	74.6	4.0	E
EB	Left Turn	10	1	10.0%	3.8	437.2	440.9	F
	Through	990	142	14.3%	35.7	543.8	76.6	F
	Right Turn	320	44	13.8%	20.4	423.7	72.6	F
	Subtotal	1320	187	14.2%	41.3	515.9	74.2	F
WB	Left Turn	30	9	30.0%	4.8	97.0	24.1	F
	Through	670	187	27.9%	23.4	97.4	9.0	F
	Right Turn	450	125	27.8%	19.2	89.3	9.8	F
	Subtotal	1150	321	27.9%	30.6	94.1	9.2	F
Total		5350	2743	51.3%	41.0	131.7	3.0	F

Intersection

Arguello St/Broadway

Signalized

Direction	Movement	Volume (veh/hr)			GEH	Total Delay (sec/veh)		
		Demand	Served	% Served		Average	Std. Dev.	LOS
NB	Left Turn	250	68	27.2%	14.4	502.7	130.7	F
	Through	200	50	25.0%	13.4	533.9	138.0	F
	Right Turn	50	14	27.4%	6.4	469.8	138.5	F
	Subtotal	500	132	26.3%	20.7	509.4	126.3	F
SB	Left Turn	160	87	54.5%	6.5	201.1	22.1	F
	Through	300	171	56.9%	8.4	190.3	21.4	F
	Right Turn	270	155	57.3%	7.9	207.8	27.6	F
	Subtotal	730	413	56.5%	13.3	199.3	22.1	F
EB	Left Turn	110	27	24.5%	10.0	13.8	5.8	B
	Through	1100	257	23.4%	32.4	13.1	0.6	B
	Right Turn	310	67	21.7%	17.7	2.7	0.8	A
	Subtotal	1520	351	23.1%	38.2	11.2	0.6	B
WB	Left Turn	30	5	17.7%	5.9	252.1	65.8	F
	Through	880	186	21.1%	30.1	229.5	22.7	F
	Right Turn	170	32	18.6%	13.8	123.9	16.3	F
	Subtotal	1080	223	20.6%	33.6	215.0	20.5	F
Total		3830	1119	29.2%	54.5	176.2	19.6	F

SimTraffic Post-Processor
Average Results from 20 Runs
Volume and Delay by Movement

Caltrain Electrification
2040 Plus Project Conditions
AM Peak Hour

Intersection

El Camino Real/James

Signalized

Direction	Movement	Volume (veh/hr)			GEH	Total Delay (sec/veh)		
		Demand	Served	% Served		Average	Std. Dev.	LOS
NB	Left Turn	179	126	70.2%	4.3	263.4	12.1	F
	Through	1305	941	72.1%	10.9	270.2	15.2	F
	Right Turn	63	49	77.0%	1.9	166.8	12.7	F
	Subtotal	1547	1115	72.1%	11.8	264.9	14.1	F
SB	Left Turn	105	60	56.8%	5.0	52.3	4.7	D
	Through	1400	896	64.0%	14.9	29.7	2.0	C
	Right Turn	116	69	59.7%	4.9	15.8	1.8	B
	Subtotal	1621	1025	63.2%	16.4	30.0	1.9	C
EB	Left Turn	147	139	94.5%	0.7	88.7	18.3	F
	Through	116	113	97.4%	0.3	20.9	7.0	C
	Right Turn	179	172	96.3%	0.5	17.7	6.6	B
	Subtotal	442	424	96.0%	0.9	41.7	9.4	D
WB	Left Turn	200	42	20.9%	14.4	42.6	24.2	D
	Through	326	65	20.0%	18.6	35.3	24.9	D
	Right Turn	147	35	23.6%	11.8	41.1	8.2	D
	Subtotal	673	142	21.1%	26.3	38.4	18.1	D
Total		4283	2706	63.2%	26.7	128.8	4.1	F

SimTraffic Post-Processor
Average Results from 20 Runs
Volume and Delay by Movement

Caltrain Electrification
2040 Plus Project Conditions
AM Peak Hour

Intersection

El Camino Real/Atherton Avenue-Fair Oaks Lane

Signalized

Direction	Movement	Volume (veh/hr)			GEH	Total Delay (sec/veh)		
		Demand	Served	% Served		Average	Std. Dev.	LOS
NB	Left Turn	120	109	90.5%	1.1	310.2	142.5	F
	Through	1620	1553	95.9%	1.7	46.8	9.7	D
	Right Turn	30	27	90.0%	0.6	51.5	13.3	D
	Subtotal	1770	1689	95.4%	2.0	63.9	17.6	E
SB	Left Turn	140	112	80.1%	2.5	462.6	49.8	F
	Through	1830	1547	84.5%	6.9	449.5	63.1	F
	Right Turn	190	164	86.1%	2.0	469.3	54.1	F
	Subtotal	2160	1822	84.4%	7.6	452.1	60.8	F
EB	Left Turn	120	118	98.4%	0.2	176.6	115.3	F
	Through	180	173	96.1%	0.5	175.7	112.0	F
	Right Turn	200	195	97.4%	0.4	161.2	115.6	F
	Subtotal	500	486	97.2%	0.6	170.1	114.0	F
WB	Left Turn	80	81	101.4%	0.1	150.4	83.1	F
	Through	150	148	98.7%	0.2	146.7	87.4	F
	Right Turn	70	64	91.3%	0.7	110.5	79.4	F
	Subtotal	300	293	97.7%	0.4	139.9	84.9	F
Total		4730	4290	90.7%	6.6	246.0	20.2	F

Intersection

El Camino Real/Watkins Avenue

Unsignalized

Direction	Movement	Volume (veh/hr)			GEH	Total Delay (sec/veh)		
		Demand	Served	% Served		Average	Std. Dev.	LOS
NB	Left Turn							
	Through	1640	1626	99.1%	0.4	1.8	0.1	A
	Right Turn	80	79	98.3%	0.2	2.9	0.3	A
	Subtotal	1720	1704	99.1%	0.4	1.8	0.1	A
SB	Left Turn	70	63	90.0%	0.9	29.8	6.1	D
	Through	2040	1770	86.8%	6.2	5.2	0.2	A
	Right Turn							
	Subtotal	2110	1833	86.9%	6.2	6.0	0.4	A
EB	Left Turn							
	Through							
	Right Turn							
	Subtotal							
WB	Left Turn	80	37	46.0%	5.7	1328.2	287.0	F
	Through							
	Right Turn	130	61	47.1%	7.0	1262.5	256.6	F
	Subtotal	210	98	46.7%	9.0	1287.8	266.7	F
Total		4040	3636	90.0%	6.5	37.8	5.0	E

Intersection

El Camino Real/Glenwood

Signalized

Direction	Movement	Volume (veh/hr)			GEH	Total Delay (sec/veh)		
		Demand	Served	% Served		Average	Std. Dev.	LOS
NB	Left Turn	70	69	97.9%	0.2	58.5	6.0	E
	Through	1040	978	94.0%	2.0	17.6	1.0	B
	Right Turn	40	37	92.0%	0.5	11.8	0.9	B
	Subtotal	1150	1083	94.2%	2.0	20.0	0.7	B
SB	Left Turn	230	163	71.0%	4.7	261.9	20.0	F
	Through	1230	827	67.2%	12.6	292.1	24.4	F
	Right Turn							
	Subtotal	1460	990	67.8%	13.4	287.3	22.2	F
EB	Left Turn	320	212	66.1%	6.6	235.4	13.4	F
	Through	210	139	66.3%	5.4	238.7	12.7	F
	Right Turn	280	192	68.4%	5.8	266.5	20.1	F
	Subtotal	810	542	67.0%	10.3	247.2	14.2	F
WB	Left Turn	100	94	94.0%	0.6	199.3	81.3	F
	Through	190	184	96.6%	0.5	211.1	88.7	F
	Right Turn	100	93	92.8%	0.7	193.3	82.6	F
	Subtotal	390	370	94.9%	1.0	203.6	85.4	F
Total		3810	2986	78.4%	14.1	172.3	9.2	F

Intersection

El Camino Real/Oak Grove

Signalized

Direction	Movement	Volume (veh/hr)			GEH	Total Delay (sec/veh)		
		Demand	Served	% Served		Average	Std. Dev.	LOS
NB	Left Turn	100	89	89.3%	1.1	45.4	4.8	D
	Through	1020	962	94.4%	1.8	11.9	0.9	B
	Right Turn	80	82	102.9%	0.3	5.0	0.9	A
	Subtotal	1200	1134	94.5%	1.9	14.0	1.0	B
SB	Left Turn	190	134	70.3%	4.4	194.7	10.2	F
	Through	1340	915	68.3%	12.7	200.0	10.3	F
	Right Turn	80	51	64.0%	3.6	181.9	9.4	F
	Subtotal	1610	1100	68.3%	13.9	198.5	9.5	F
EB	Left Turn	70	64	91.1%	0.8	69.4	10.1	E
	Through	210	209	99.7%	0.0	50.5	7.1	D
	Right Turn	60	64	107.3%	0.6	36.2	7.1	D
	Subtotal	340	338	99.3%	0.1	51.5	7.6	D
WB	Left Turn	200	188	94.1%	0.8	123.7	18.1	F
	Through	240	227	94.5%	0.9	81.3	11.4	F
	Right Turn	60	60	100.2%	0.0	36.1	9.2	D
	Subtotal	500	475	95.0%	1.1	92.4	13.2	F
Total		3650	3046	83.5%	10.4	96.9	3.4	F

Intersection

El Camino Real/Santa Cruz Ave

Signalized

Direction	Movement	Volume (veh/hr)			GEH	Total Delay (sec/veh)		
		Demand	Served	% Served		Average	Std. Dev.	LOS
NB	Left Turn							
	Through	1030	989	96.0%	1.3	4.0	0.3	A
	Right Turn	50	48	95.0%	0.4	3.3	0.4	A
	Subtotal	1080	1037	96.0%	1.3	4.0	0.3	A
SB	Left Turn							
	Through	1500	1101	73.4%	11.1	64.2	3.4	E
	Right Turn	100	75	74.9%	2.7	43.4	9.4	D
	Subtotal	1600	1175	73.5%	11.4	62.9	3.7	E
EB	Left Turn	100	102	102.2%	0.2	41.0	8.0	D
	Through	70	69	98.4%	0.1	39.1	8.4	D
	Right Turn	270	258	95.5%	0.8	48.4	11.3	D
	Subtotal	440	429	97.5%	0.5	45.2	9.8	D
WB	Left Turn	190	185	97.2%	0.4	47.4	3.9	D
	Through	70	80	114.4%	1.2	44.6	4.5	D
	Right Turn	70	61	87.3%	1.1	30.0	4.4	C
	Subtotal	330	326	98.8%	0.2	43.5	3.2	D
Total		3450	2967	86.0%	8.5	37.7	1.8	D

Intersection

Merril St/Santa Cruz Ave

Unsignalized

Direction	Movement	Volume (veh/hr)			GEH	Total Delay (sec/veh)		
		Demand	Served	% Served		Average	Std. Dev.	LOS
NB	Left Turn	190	184	96.8%	0.4	9.8	3.0	A
	Through	100	106	105.8%	0.6	10.2	2.6	B
	Right Turn	10	13	129.0%	0.9	6.6	2.2	A
	Subtotal	300	303	100.9%	0.1	9.8	2.7	A
SB	Left Turn	20	18	92.0%	0.4	9.3	0.9	A
	Through	30	32	106.3%	0.3	11.1	2.1	B
	Right Turn	90	91	100.9%	0.1	9.2	2.0	A
	Subtotal	140	141	100.8%	0.1	9.7	1.7	A
EB	Left Turn	60	60	99.7%	0.0	9.1	1.3	A
	Through	60	60	100.0%	0.0	10.1	1.1	B
	Right Turn							
	Subtotal	120	120	99.8%	0.0	9.6	1.1	A
WB	Left Turn	10	9	87.0%	0.4	7.4	3.1	A
	Through	50	45	90.6%	0.7	9.1	1.8	A
	Right Turn	30	31	102.7%	0.1	4.8	1.0	A
	Subtotal	90	85	94.2%	0.6	7.4	1.4	A
Total		650	648	99.7%	0.1	9.4	1.9	A

Intersection

Ravenswood Ave/Laurel St

Signalized

Direction	Movement	Volume (veh/hr)			GEH	Total Delay (sec/veh)		
		Demand	Served	% Served		Average	Std. Dev.	LOS
NB	Left Turn	179	170	94.7%	0.7	34.6	5.2	C
	Through	74	70	94.9%	0.4	21.4	2.8	C
	Right Turn	32	31	96.9%	0.2	20.0	3.9	B
	Subtotal	285	271	95.0%	0.9	29.6	3.9	C
SB	Left Turn	347	191	55.2%	9.5	291.1	16.6	F
	Through	179	101	56.4%	6.6	290.0	17.4	F
	Right Turn	84	49	58.1%	4.3	284.1	17.1	F
	Subtotal	610	341	55.9%	12.3	289.7	16.4	F
EB	Left Turn	42	35	83.8%	1.1	74.6	14.4	E
	Through	905	793	87.6%	3.9	32.7	3.7	C
	Right Turn	116	100	86.1%	1.5	29.9	5.2	C
	Subtotal	1063	928	87.3%	4.3	34.0	3.7	C
WB	Left Turn	21	19	88.6%	0.5	100.3	24.9	F
	Through	705	666	94.5%	1.5	72.2	33.5	E
	Right Turn	189	185	98.0%	0.3	67.5	32.9	E
	Subtotal	915	870	95.1%	1.5	71.9	32.9	E
Total		2873	2409	83.9%	9.0	83.4	13.1	F

SimTraffic Post-Processor
Average Results from 10 Runs
Volume and Delay by Movement

Caltrain Electrification
2040 Plus Project Conditions
AM Peak Hour

Intersection

High Street/University Ave

Signalized

Direction	Movement	Volume (veh/hr)			GEH	Total Delay (sec/veh)		
		Demand	Served	% Served		Average	Std. Dev.	LOS
NB	Left Turn							
	Through							
	Right Turn							
	Subtotal							
SB	Left Turn	20	20	102.0%	0.1	14.9	3.6	B
	Through	40	40	100.0%	0.0	10.4	3.1	B
	Right Turn	300	303	101.0%	0.2	19.6	2.3	B
	Subtotal	360	363	100.9%	0.2	18.3	1.9	B
EB	Left Turn							
	Through	780	775	99.3%	0.2	9.9	0.9	A
	Right Turn	370	361	97.6%	0.5	4.7	0.3	A
	Subtotal	1150	1136	98.8%	0.4	8.3	0.6	A
WB	Left Turn	20	19	94.5%	0.2	34.7	7.0	C
	Through	770	745	96.8%	0.9	18.9	1.4	B
	Right Turn							
	Subtotal	790	764	96.7%	0.9	19.3	1.6	B
Total		2300	2263	98.4%	0.8	13.6	0.6	B

SimTraffic Post-Processor
Average Results from 10 Runs
Volume and Delay by Movement

Caltrain Electrification
2040 Plus Project Conditions
AM Peak Hour

Intersection

Showers Drive/Pacchetti Way

Signalized

Direction	Movement	Volume (veh/hr)			GEH	Total Delay (sec/veh)		
		Demand	Served	% Served		Average	Std. Dev.	LOS
NB	Left Turn	20	20	98.5%	0.1	23.8	2.5	C
	Through	40	38	93.8%	0.4	1.8	0.9	A
	Right Turn							
	Subtotal	60	57	95.3%	0.4	9.3	1.4	A
SB	Left Turn							
	Through	90	89	99.3%	0.1	3.6	1.2	A
	Right Turn	40	40	99.8%	0.0	1.5	0.8	A
	Subtotal	130	129	99.5%	0.1	2.9	0.9	A
EB	Left Turn	10	9	93.0%	0.2	14.7	3.0	B
	Through							
	Right Turn	10	9	87.0%	0.4	3.1	0.9	A
	Subtotal	20	18	90.0%	0.5	9.0	1.7	A
WB	Left Turn							
	Through							
	Right Turn							
	Subtotal							
Total		210	205	97.4%	0.4	5.2	0.9	A

Intersection Hope Street/Evelyn Ave

Signalized

Direction	Movement	Volume (veh/hr)			GEH	Total Delay (sec/veh)		
		Demand	Served	% Served		Average	Std. Dev.	LOS
NB	Left Turn	20	15	75.5%	1.2	28.4	5.9	C
	Through							
	Right Turn	80	74	92.3%	0.7	5.6	0.5	A
	Subtotal	100	89	88.9%	1.1	9.3	0.9	A
SB	Left Turn							
	Through							
	Right Turn							
	Subtotal							
EB	Left Turn							
	Through	110	105	95.3%	0.5	1.5	0.4	A
	Right Turn	10	9	92.0%	0.3	0.3	0.1	A
	Subtotal	120	114	95.0%	0.6	1.4	0.4	A
WB	Left Turn	60	58	96.8%	0.2	1.7	0.8	A
	Through	600	611	101.8%	0.4	2.0	0.2	A
	Right Turn							
	Subtotal	660	669	101.3%	0.3	2.0	0.2	A
Total		880	872	99.0%	0.3	2.6	0.3	A

Intersection Castro Street/Villa Street

Signalized

Direction	Movement	Volume (veh/hr)			GEH	Total Delay (sec/veh)		
		Demand	Served	% Served		Average	Std. Dev.	LOS
NB	Left Turn	20	19	92.5%	0.3	66.5	15.6	E
	Through	190	188	98.9%	0.1	33.2	4.2	C
	Right Turn	160	157	98.2%	0.2	23.7	4.9	C
	Subtotal	370	364	98.3%	0.3	30.8	4.4	C
SB	Left Turn	170	165	96.8%	0.4	40.1	12.5	D
	Through	210	218	103.8%	0.5	32.9	3.1	C
	Right Turn	360	350	97.2%	0.5	25.8	2.2	C
	Subtotal	740	732	99.0%	0.3	31.2	4.0	C
EB	Left Turn	270	210	77.9%	3.8	217.6	14.5	F
	Through	270	205	76.0%	4.2	213.8	15.1	F
	Right Turn	10	9	88.0%	0.4	200.3	23.8	F
	Subtotal	550	425	77.2%	5.7	215.4	14.2	F
WB	Left Turn	60	56	93.5%	0.5	30.7	3.3	C
	Through	220	217	98.6%	0.2	26.8	2.9	C
	Right Turn	100	98	97.6%	0.2	21.3	5.4	C
	Subtotal	380	371	97.6%	0.5	25.9	3.4	C
Total		2040	1891	92.7%	3.4	71.4	3.0	E

SimTraffic Post-Processor
Average Results from 10 Runs
Volume and Delay by Movement

Caltrain Electrification
2040 Plus Project Conditions
AM Peak Hour

Intersection

Frances St/Evelyn Ave

Signalized

Direction	Movement	Volume (veh/hr)			GEH	Total Delay (sec/veh)		
		Demand	Served	% Served		Average	Std. Dev.	LOS
NB	Left Turn	100	102	102.0%	0.2	25.5	3.6	C
	Through	50	53	106.6%	0.5	24.4	3.4	C
	Right Turn	10	9	89.0%	0.4	17.3	5.0	B
	Subtotal	160	164	102.6%	0.3	24.7	3.0	C
SB	Left Turn	270	225	83.2%	2.9	626.9	149.1	F
	Through	50	39	77.2%	1.7	660.4	127.4	F
	Right Turn	220	178	80.9%	3.0	608.8	127.5	F
	Subtotal	540	441	81.7%	4.5	622.2	136.3	F
EB	Left Turn	170	90	53.1%	7.0	837.2	49.0	F
	Through	320	184	57.4%	8.6	487.8	42.4	F
	Right Turn	30	17	56.3%	2.7	487.7	47.9	F
	Subtotal	520	291	55.9%	11.4	596.5	50.0	F
WB	Left Turn	40	27	67.0%	2.3	90.6	46.5	F
	Through	700	555	79.3%	5.8	88.4	22.6	F
	Right Turn	420	330	78.6%	4.6	60.0	14.2	E
	Subtotal	1160	912	78.6%	7.7	78.4	15.8	E
Total		2380	1808	76.0%	12.5	287.9	26.9	F

SimTraffic Post-Processor
Average Results from 20 Runs
Volume and Delay by Movement

Caltrain Electrification
2040 Plus Project Conditions
AM Peak Hour

Intersection Lawrence Expressway/Kifer Road

Signalized

Direction	Movement	Volume (veh/hr)			GEH	Total Delay (sec/veh)		
		Demand	Served	% Served		Average	Std. Dev.	LOS
NB	Left Turn	460	292	63.4%	8.7	184.7	4.0	F
	Through	5130	3281	64.0%	28.5	208.0	2.5	F
	Right Turn	720	450	62.6%	11.1	231.1	3.6	F
	Subtotal	6310	4023	63.8%	31.8	208.9	2.5	F
SB	Left Turn	280	173	61.8%	7.1	1010.0	58.5	F
	Through	1540	1096	71.2%	12.2	86.8	6.8	F
	Right Turn	410	296	72.1%	6.1	64.4	5.0	E
	Subtotal	2230	1565	70.2%	15.3	185.5	18.3	F
EB	Left Turn	220	197	89.4%	1.6	392.3	162.9	F
	Through	340	345	101.5%	0.3	75.6	4.4	E
	Right Turn	280	288	102.8%	0.5	2.2	0.2	A
	Subtotal	840	830	98.8%	0.4	124.3	34.3	F
WB	Left Turn	160	155	97.0%	0.4	86.5	5.7	F
	Through	840	760	90.5%	2.8	268.6	28.5	F
	Right Turn	170	149	87.8%	1.6	252.7	26.6	F
	Subtotal	1170	1064	91.0%	3.2	239.9	24.7	F
Total		10550	7482	70.9%	32.3	198.9	5.2	F

Intersection Lawrence Expressway/Reed Ave-Monroe St

Signalized

Direction	Movement	Volume (veh/hr)			GEH	Total Delay (sec/veh)		
		Demand	Served	% Served		Average	Std. Dev.	LOS
NB	Left Turn	220	139	63.3%	6.0	190.5	3.9	F
	Through	5460	3461	63.4%	29.9	120.6	2.3	F
	Right Turn	150	99	65.8%	4.6	97.6	4.5	F
	Subtotal	5830	3699	63.5%	30.9	122.6	2.2	F
SB	Left Turn	110	85	76.8%	2.6	68.5	17.8	E
	Through	1660	1310	78.9%	9.1	15.0	0.6	B
	Right Turn	210	166	79.0%	3.2	10.4	0.6	B
	Subtotal	1980	1560	78.8%	10.0	17.4	1.4	B
EB	Left Turn	490	391	79.8%	4.7	530.9	112.6	F
	Through	440	427	97.0%	0.6	111.9	11.6	F
	Right Turn	310	291	93.9%	1.1	15.7	9.2	B
	Subtotal	1240	1109	89.4%	3.8	234.9	46.5	F
WB	Left Turn	260	170	65.5%	6.1	320.7	85.6	F
	Through	320	216	67.5%	6.3	381.8	117.4	F
	Right Turn	360	193	53.6%	10.0	606.8	177.8	F
	Subtotal	940	580	61.6%	13.1	439.8	33.5	F
Total		9990	6948	69.6%	33.1	143.1	8.5	F

SimTraffic Post-Processor
Average Results from 10 Runs
Volume and Delay by Movement

Caltrain Electrification
2040 Plus Project Conditions
AM Peak Hour

Intersection

El Camino Real/Railroad Avenue

Signalized

Direction	Movement	Volume (veh/hr)			GEH	Total Delay (sec/veh)		
		Demand	Served	% Served		Average	Std. Dev.	LOS
NB	Left Turn	330	239	72.5%	5.4	605.4	58.9	F
	Through	1720	1553	90.3%	4.1	25.4	3.1	C
	Right Turn	70	59	84.7%	1.3	24.6	4.0	C
	Subtotal	2120	1851	87.3%	6.0	100.4	8.5	F
SB	Left Turn	80	76	94.4%	0.5	37.4	3.2	D
	Through	640	649	101.4%	0.4	15.1	0.8	B
	Right Turn	160	167	104.6%	0.6	15.0	1.5	B
	Subtotal	880	892	101.4%	0.4	17.0	0.8	B
EB	Left Turn	10	10	98.0%	0.1	27.4	7.4	C
	Through	10	10	97.0%	0.1	13.7	4.8	B
	Right Turn	30	30	101.3%	0.1	7.9	0.7	A
	Subtotal	50	50	99.8%	0.0	12.8	2.0	B
WB	Left Turn	80	78	97.8%	0.2	30.5	2.6	C
	Through	20	19	94.5%	0.2	18.3	3.0	B
	Right Turn	60	58	97.0%	0.2	11.0	1.8	B
	Subtotal	160	155	97.1%	0.4	21.7	2.0	C
Total		3210	2948	91.9%	4.7	69.5	5.2	E

SimTraffic Post-Processor
Average Results from 10 Runs
Volume and Delay by Movement

Caltrain Electrification
2040 Plus Project Conditions
AM Peak Hour

Intersection Santa Clara Street/Cahill Street

Signalized

Direction	Movement	Volume (veh/hr)			GEH	Total Delay (sec/veh)		
		Demand	Served	% Served		Average	Std. Dev.	LOS
NB	Left Turn	270	267	98.8%	0.2	34.7	4.2	C
	Through	10	18	179.0%	2.1	20.0	6.5	B
	Right Turn	160	148	92.6%	1.0	13.6	2.4	B
	Subtotal	440	433	98.3%	0.3	26.8	3.2	C
SB	Left Turn	10	8	80.0%	0.7	56.4	15.2	E
	Through	10	11	110.0%	0.3	50.8	7.4	D
	Right Turn	10	10	100.0%	0.0	16.2	7.9	B
	Subtotal	30	29	96.7%	0.2	40.6	7.1	D
EB	Left Turn							
	Through	740	671	90.7%	2.6	138.3	14.4	F
	Right Turn	240	214	89.1%	1.7	162.0	29.4	F
	Subtotal	980	885	90.3%	3.1	144.1	16.8	F
WB	Left Turn	530	370	69.8%	7.5	117.1	15.0	F
	Through	1340	981	73.2%	10.6	45.6	13.1	D
	Right Turn	20	15	76.0%	1.1	82.3	111.9	F
	Subtotal	1890	1366	72.3%	13.0	65.4	11.3	E
Total		3340	2712	81.2%	11.4	84.5	7.0	F

Intersection San Fernando Street/Montgomery Street

Signalized

Direction	Movement	Volume (veh/hr)			GEH	Total Delay (sec/veh)		
		Demand	Served	% Served		Average	Std. Dev.	LOS
NB	Left Turn							
	Through							
	Right Turn							
	Subtotal							
SB	Left Turn	80	65	81.6%	1.7	43.6	18.0	D
	Through	600	485	80.9%	4.9	102.9	29.7	F
	Right Turn	20	15	75.5%	1.2	107.0	46.2	F
	Subtotal	700	566	80.8%	5.3	96.3	29.2	F
EB	Left Turn							
	Through	240	205	85.5%	2.3	12.5	1.1	B
	Right Turn	170	144	84.6%	2.1	11.1	1.3	B
	Subtotal	410	349	85.1%	3.1	11.9	0.9	B
WB	Left Turn	200	198	98.8%	0.2	39.1	9.2	D
	Through	490	491	100.2%	0.0	33.7	9.3	C
	Right Turn							
	Subtotal	690	689	99.8%	0.1	35.3	9.1	D
Total		1800	1603	89.1%	4.8	51.6	11.9	D

SimTraffic Post-Processor
Average Results from 10 Runs
Volume and Delay by Movement

Caltrain Electrification
2040 Plus Project Conditions
AM Peak Hour

Intersection

Lick Avenue-Shadow Run Drive/Alma Avenue

Signalized

Direction	Movement	Volume (veh/hr)			GEH	Total Delay (sec/veh)		
		Demand	Served	% Served		Average	Std. Dev.	LOS
NB	Left Turn	40	40	99.8%	0.0	62.6	6.1	E
	Through	60	59	98.7%	0.1	62.1	7.8	E
	Right Turn	20	20	101.5%	0.1	32.9	8.5	C
	Subtotal	120	119	99.5%	0.1	57.1	6.1	E
SB	Left Turn	70	67	95.3%	0.4	71.7	5.3	E
	Through	10	11	110.0%	0.3	58.9	13.4	E
	Right Turn	140	142	101.1%	0.1	13.7	5.6	B
	Subtotal	220	219	99.6%	0.1	33.7	5.0	C
EB	Left Turn	220	177	80.3%	3.1	549.2	85.6	F
	Through	740	735	99.3%	0.2	16.9	4.2	B
	Right Turn	20	21	102.5%	0.1	20.8	37.5	C
	Subtotal	980	932	95.1%	1.5	117.4	14.9	F
WB	Left Turn	10	10	98.0%	0.1	102.3	14.7	F
	Through	930	938	100.8%	0.3	27.4	1.8	C
	Right Turn	700	681	97.2%	0.7	43.6	5.6	D
	Subtotal	1640	1628	99.3%	0.3	34.6	3.4	C
Total		2960	2899	97.9%	1.1	62.1	4.8	E

Intersection 7th Street/Mission Bay

Signalized

Direction	Movement	Volume (veh/hr)			GEH	Total Delay (sec/veh)		
		Demand	Served	% Served		Average	Std. Dev.	LOS
NB	Left Turn	10	11	108.0%	0.2	38.0	7.0	D
	Through	1020	1025	100.5%	0.2	20.3	2.4	C
	Right Turn	70	68	97.4%	0.2	18.8	2.6	B
	Subtotal	1100	1104	100.4%	0.1	20.3	2.4	C
SB	Left Turn	50	48	96.8%	0.2	36.4	5.5	D
	Through	370	361	97.7%	0.4	7.9	0.4	A
	Right Turn	10	12	116.0%	0.5	4.5	2.0	A
	Subtotal	430	421	98.0%	0.4	11.1	1.1	B
EB	Left Turn							
	Through							
	Right Turn							
	Subtotal							
WB	Left Turn	30	30	99.3%	0.0	3.8	1.4	A
	Through							
	Right Turn	90	92	102.6%	0.2	0.9	0.2	A
	Subtotal	120	122	101.8%	0.2	1.6	0.4	A
Total		1650	1648	99.9%	0.1	16.6	1.7	B

Intersection Berry Street/Mission Bay

Signalized

Direction	Movement	Volume (veh/hr)			GEH	Total Delay (sec/veh)		
		Demand	Served	% Served		Average	Std. Dev.	LOS
NB	Left Turn							
	Through							
	Right Turn							
	Subtotal							
SB	Left Turn							
	Through							
	Right Turn	120	122	101.3%	0.1	3.2	1.4	A
	Subtotal	120	122	101.3%	0.1	3.2	1.4	A
EB	Left Turn	120	117	97.3%	0.3	1.0	0.8	A
	Through							
	Right Turn							
	Subtotal	120	117	97.3%	0.3	1.0	0.8	A
WB	Left Turn							
	Through							
	Right Turn							
	Subtotal							
Total		240	238	99.3%	0.1	2.1	0.8	A

Intersection **Main Street/Maple Street** Unsignalized

Direction	Movement	Volume (veh/hr)			GEH	Total Delay (sec/veh)		
		Demand	Served	% Served		Average	Std. Dev.	LOS
NB	Left Turn							
	Through	470	464	98.7%	0.3	8.1	2.2	A
	Right Turn							
	Subtotal	470	464	98.7%	0.3	8.1	2.2	A
SB	Left Turn							
	Through	310	245	79.1%	3.9	5.0	0.6	A
	Right Turn							
	Subtotal	310	245	79.1%	3.9	5.0	0.6	A
EB	Left Turn							
	Through							
	Right Turn							
	Subtotal							
WB	Left Turn							
	Through							
	Right Turn	20	21	102.5%	0.1	22.2	14.4	C
	Subtotal	20	21	102.5%	0.1	22.2	14.4	C
Total		800	729	91.2%	2.6	7.5	1.6	A

Intersection **Main Street/Beech Street** Unsignalized

Direction	Movement	Volume (veh/hr)			GEH	Total Delay (sec/veh)		
		Demand	Served	% Served		Average	Std. Dev.	LOS
NB	Left Turn	140	147	105.0%	0.6	8.2	3.3	A
	Through	430	426	99.0%	0.2	5.3	2.8	A
	Right Turn							
	Subtotal	570	573	100.5%	0.1	6.0	2.9	A
SB	Left Turn							
	Through	360	316	87.8%	2.4	2.0	0.5	A
	Right Turn	100	89	89.3%	1.1	0.9	0.3	A
	Subtotal	460	405	88.1%	2.6	1.7	0.4	A
EB	Left Turn	40	36	90.8%	0.6	26.7	6.8	D
	Through							
	Right Turn	120	121	100.6%	0.1	11.5	2.8	B
	Subtotal	160	157	98.1%	0.2	15.0	3.3	B
WB	Left Turn							
	Through							
	Right Turn							
	Subtotal							
Total		1190	1135	95.4%	1.6	5.7	1.9	A

Intersection

Main Street/Middlefield Road

Signalized

Direction	Movement	Volume (veh/hr)			GEH	Total Delay (sec/veh)		
		Demand	Served	% Served		Average	Std. Dev.	LOS
NB	Left Turn	50	53	105.6%	0.4	61.5	5.6	E
	Through	400	397	99.2%	0.2	40.1	2.9	D
	Right Turn	40	39	97.3%	0.2	38.4	7.4	D
	Subtotal	490	489	99.7%	0.1	42.3	2.9	D
SB	Left Turn	130	84	64.2%	4.5	1616.1	357.9	F
	Through	240	183	76.2%	3.9	517.6	242.3	F
	Right Turn	50	43	86.6%	1.0	472.2	273.6	F
	Subtotal	420	310	73.7%	5.8	810.5	292.9	F
EB	Left Turn	80	74	92.6%	0.7	273.8	99.2	F
	Through	780	775	99.4%	0.2	81.5	64.8	F
	Right Turn	50	49	97.8%	0.2	67.4	60.7	E
	Subtotal	910	898	98.7%	0.4	97.0	65.6	F
WB	Left Turn	20	14	68.0%	1.6	61.0	20.4	E
	Through	740	604	81.7%	5.2	6.5	0.6	A
	Right Turn	150	114	76.1%	3.1	0.7	0.4	A
	Subtotal	910	732	80.5%	6.2	6.6	0.8	A
Total		2730	2429	89.0%	5.9	146.9	45.0	F

SimTraffic Post-Processor
Average Results from 20 Runs
Volume and Delay by Movement

Caltrain Electrification
2040 Plus Project Conditions
AM Peak Hour

Intersection Fair Oaks Lane/Middlefield Road

Unsignalized

Direction	Movement	Volume (veh/hr)			GEH	Total Delay (sec/veh)		
		Demand	Served	% Served		Average	Std. Dev.	LOS
NB	Left Turn	20	3	12.5%	5.2	4285.1	2837.7	F
	Through	10	2	18.0%	3.4	5280.1	5260.9	F
	Right Turn	300	56	18.8%	18.3	3948.7	3989.1	F
	Subtotal	330	61	18.4%	19.3	3996.2	4019.2	F
SB	Left Turn	20	1	3.5%	6.0	7384.4	5297.5	F
	Through	90	5	5.2%	12.4	16059.9	11758.2	F
	Right Turn	60	3	5.0%	10.2	23600.2	22268.3	F
	Subtotal	170	8	4.9%	17.1	15929.9	11821.3	F
EB	Left Turn	10	10	95.0%	0.2	13.2	6.2	B
	Through	750	742	99.0%	0.3	7.4	0.9	A
	Right Turn	260	264	101.3%	0.2	5.6	1.0	A
	Subtotal	1020	1015	99.5%	0.1	6.9	0.9	A
WB	Left Turn	220	204	92.5%	1.1	130.4	38.2	F
	Through	630	585	92.9%	1.8	81.8	41.1	F
	Right Turn	20	18	90.5%	0.4	73.1	34.4	F
	Subtotal	870	807	92.7%	2.2	93.9	40.0	F
Total		2390	1891	79.1%	10.8	171.7	27.5	F

Intersection Watkins Avenue/Middlefield Road

Unsignalized

Direction	Movement	Volume (veh/hr)			GEH	Total Delay (sec/veh)		
		Demand	Served	% Served		Average	Std. Dev.	LOS
NB	Left Turn	70	58	82.4%	1.5	584.1	419.4	F
	Through							
	Right Turn	280	219	78.3%	3.9	522.8	373.7	F
	Subtotal	350	277	79.1%	4.1	535.5	382.4	F
SB	Left Turn							
	Through							
	Right Turn							
	Subtotal							
EB	Left Turn							
	Through	870	666	76.6%	7.4	5.9	0.3	A
	Right Turn	200	153	76.4%	3.6	4.9	0.6	A
	Subtotal	1070	819	76.5%	8.2	5.7	0.3	A
WB	Left Turn	90	81	90.3%	0.9	38.3	29.0	E
	Through	800	758	94.7%	1.5	27.4	32.6	D
	Right Turn							
	Subtotal	890	839	94.2%	1.7	28.5	32.1	D
Total		2310	1935	83.7%	8.2	81.7	37.6	F

SimTraffic Post-Processor
Average Results from 20 Runs
Volume and Delay by Movement

Caltrain Electrification
2040 Plus Project Conditions
AM Peak Hour

Intersection

Linden Avenue-Glenwood Avenue/Middlefield Road

Unsignalized

Direction	Movement	Volume (veh/hr)			GEH	Total Delay (sec/veh)		
		Demand	Served	% Served		Average	Std. Dev.	LOS
NB	Left Turn	70	35	50.1%	4.8	1570.6	487.8	F
	Through	10	5	49.0%	1.9	1632.6	656.0	F
	Right Turn	220	104	47.2%	9.1	1351.5	443.6	F
	Subtotal	300	144	47.9%	10.5	1414.2	460.7	F
SB	Left Turn	60	28	46.5%	4.8	1985.5	614.5	F
	Through	10	5	45.0%	2.0	2285.3	1028.3	F
	Right Turn	40	16	40.0%	4.5	2165.5	1014.6	F
	Subtotal	110	48	44.0%	6.9	2034.9	675.4	F
EB	Left Turn	50	35	70.6%	2.3	15.3	3.4	C
	Through	770	599	77.8%	6.5	9.6	0.7	A
	Right Turn	330	259	78.5%	4.1	7.8	0.7	A
	Subtotal	1150	894	77.7%	8.0	9.3	0.7	A
WB	Left Turn	160	162	101.0%	0.1	32.0	14.4	D
	Through	780	780	100.0%	0.0	4.4	3.6	A
	Right Turn	10	11	107.0%	0.2	4.5	5.5	A
	Subtotal	950	952	100.2%	0.1	9.1	5.2	A
Total		2510	2038	81.2%	9.9	142.5	24.7	F

SimTraffic Post-Processor
Average Results from 20 Runs
Volume and Delay by Movement

Caltrain Electrification
2040 Plus Project Conditions
AM Peak Hour

Intersection California Street/Rengstorff Avenue

Signalized

Direction	Movement	Volume (veh/hr)			GEH	Total Delay (sec/veh)		
		Demand	Served	% Served		Average	Std. Dev.	LOS
NB	Left Turn	280	251	89.8%	1.8	209.1	25.2	F
	Through	830	765	92.1%	2.3	214.5	27.0	F
	Right Turn	380	344	90.6%	1.9	224.6	31.8	F
	Subtotal	1490	1360	91.3%	3.4	216.1	27.6	F
SB	Left Turn	130	126	96.7%	0.4	94.8	11.1	F
	Through	220	225	102.0%	0.3	45.8	2.6	D
	Right Turn	90	91	100.8%	0.1	33.5	4.2	C
	Subtotal	440	441	100.2%	0.0	57.3	4.5	E
EB	Left Turn	210	156	74.2%	4.0	352.2	37.3	F
	Through	770	603	78.3%	6.4	215.0	9.6	F
	Right Turn	180	142	78.9%	3.0	203.4	12.4	F
	Subtotal	1160	901	77.7%	8.1	237.1	10.3	F
WB	Left Turn	200	173	86.3%	2.0	245.4	27.8	F
	Through	740	656	88.6%	3.2	184.8	10.7	F
	Right Turn	240	212	88.2%	1.9	189.9	9.5	F
	Subtotal	1180	1040	88.2%	4.2	196.0	13.6	F
Total		4270	3743	87.6%	8.3	196.8	12.3	F

Intersection Pennsylvania Street/22nd Street

Unsignalized

Direction	Movement	Volume (veh/hr)			GEH	Total Delay (sec/veh)		
		Demand	Served	% Served		Average	Std. Dev.	LOS
NB	Left Turn	50	49	98.0%	0.1	11.2	0.8	B
	Through	240	239	99.5%	0.1	11.6	1.0	B
	Right Turn	60	57	94.5%	0.4	9.8	1.6	A
	Subtotal	350	344	98.4%	0.3	11.2	1.0	B
SB	Left Turn	20	20	100.5%	0.0	8.5	1.6	A
	Through	200	196	97.9%	0.3	8.9	0.8	A
	Right Turn	10	11	108.0%	0.2	6.3	1.4	A
	Subtotal	230	227	98.6%	0.2	8.8	0.8	A
EB	Left Turn	10	14	139.0%	1.1	6.5	0.8	A
	Through	50	52	104.0%	0.3	8.1	0.8	A
	Right Turn	70	74	105.7%	0.5	5.5	0.5	A
	Subtotal	130	140	107.6%	0.9	6.6	0.6	A
WB	Left Turn	100	102	102.2%	0.2	8.2	1.3	A
	Through	30	33	111.3%	0.6	7.9	1.9	A
	Right Turn	20	22	109.0%	0.4	5.8	1.5	A
	Subtotal	150	157	104.9%	0.6	7.8	1.4	A
Total		860	868	101.0%	0.3	9.2	0.7	A

Intersection 6 Indiana Street/22nd Street

Unsignalized

Direction	Movement	Volume (veh/hr)			GEH	Total Delay (sec/veh)		
		Demand	Served	% Served		Average	Std. Dev.	LOS
NB	Left Turn	20	20	98.0%	0.1	6.5	0.6	A
	Through	90	93	103.2%	0.3	7.4	0.5	A
	Right Turn	70	73	104.0%	0.3	5.2	0.5	A
	Subtotal	180	185	102.9%	0.4	6.4	0.4	A
SB	Left Turn	10	10	104.0%	0.1	5.7	1.3	A
	Through	20	22	108.0%	0.4	6.6	0.8	A
	Right Turn	50	49	98.4%	0.1	4.7	0.4	A
	Subtotal	80	81	101.5%	0.1	5.3	0.4	A
EB	Left Turn	10	10	98.0%	0.1	4.9	0.4	A
	Through	70	70	100.6%	0.0	5.8	0.3	A
	Right Turn	10	10	100.0%	0.0	4.1	0.8	A
	Subtotal	90	90	100.2%	0.0	5.5	0.2	A
WB	Left Turn	10	10	100.0%	0.0	6.5	1.0	A
	Through	190	193	101.5%	0.2	6.4	0.4	A
	Right Turn	10	9	89.0%	0.4	4.7	1.1	A
	Subtotal	210	212	100.8%	0.1	6.4	0.4	A
Total		560	568	101.5%	0.4	6.1	0.2	A

SimTraffic Post-Processor
Average Results from 10 Runs
Volume and Delay by Movement

Caltrain Electrification
2040 Plus Project Conditions
PM Peak Hour

Intersection

Tunnel Ave/Blanken

Unsignalized

Direction	Movement	Volume (veh/hr)			GEH	Total Delay (sec/veh)		
		Demand	Served	% Served		Average	Std. Dev.	LOS
NB	Left Turn	30	23	76.7%	1.4	224.9	10.4	F
	Through	240	187	77.8%	3.6	224.3	13.5	F
	Right Turn	10	9	92.0%	0.3	223.9	18.3	F
	Subtotal	280	219	78.2%	3.9	224.3	12.9	F
SB	Left Turn	100	96	96.3%	0.4	89.1	20.4	F
	Through	90	92	101.9%	0.2	91.2	21.8	F
	Right Turn	10	10	98.0%	0.1	81.1	22.0	F
	Subtotal	200	198	98.9%	0.2	89.7	20.6	F
EB	Left Turn	10	7	72.0%	1.0	41.0	17.6	E
	Through	60	57	94.7%	0.4	36.2	6.2	E
	Right Turn	130	128	98.8%	0.1	36.4	9.3	E
	Subtotal	200	192	96.2%	0.5	36.5	8.1	E
WB	Left Turn	10	5	53.0%	1.7	299.3	10.7	F
	Through	240	158	65.9%	5.8	300.4	8.5	F
	Right Turn	120	75	62.3%	4.6	290.6	10.6	F
	Subtotal	370	238	64.4%	7.6	297.3	8.8	F
Total		1050	847	80.7%	6.6	170.7	7.5	F

SimTraffic Post-Processor
Average Results from 10 Runs
Volume and Delay by Movement

Caltrain Electrification
2040 Plus Project Conditions
PM Peak Hour

Intersection

Dubuque Way/Grand Avenue

Signalized

Direction	Movement	Volume (veh/hr)			GEH	Total Delay (sec/veh)		
		Demand	Served	% Served		Average	Std. Dev.	LOS
NB	Left Turn							
	Through							
	Right Turn							
	Subtotal							
SB	Left Turn	30	34	114.0%	0.7	39.3	3.5	D
	Through							
	Right Turn	70	68	96.4%	0.3	15.2	1.8	B
	Subtotal	100	102	101.7%	0.2	23.3	1.9	C
EB	Left Turn	40	37	93.5%	0.4	48.3	5.7	D
	Through	240	243	101.4%	0.2	6.3	1.1	A
	Right Turn							
	Subtotal	280	281	100.3%	0.0	11.9	1.4	B
WB	Left Turn							
	Through	1660	1628	98.1%	0.8	15.1	1.0	B
	Right Turn	90	92	101.8%	0.2	16.8	2.5	B
	Subtotal	1750	1720	98.3%	0.7	15.2	1.1	B
Total		2130	2102	98.7%	0.6	15.1	0.9	B

SimTraffic Post-Processor
Average Results from 10 Runs
Volume and Delay by Movement

Caltrain Electrification
2040 Plus Project Conditions
PM Peak Hour

Intersection

Linden Avenue-San Mateo Avenue/San Mateo Avenue

Signalized

Direction	Movement	Volume (veh/hr)			GEH	Total Delay (sec/veh)		
		Demand	Served	% Served		Average	Std. Dev.	LOS
NB	Left Turn							
	Through	150	137	91.3%	1.1	17.4	10.0	B
	Right Turn	360	334	92.6%	1.4	1.9	0.2	A
	Subtotal	510	471	92.3%	1.8	6.5	3.0	A
SB	Left Turn	130	112	86.5%	1.6	41.8	18.2	D
	Through	220	209	95.0%	0.8	4.2	0.6	A
	Right Turn							
	Subtotal	350	321	91.8%	1.6	17.6	7.4	B
EB	Left Turn							
	Through							
	Right Turn							
	Subtotal							
WB	Left Turn	220	199	90.3%	1.5	19.3	5.2	B
	Through							
	Right Turn	220	202	91.6%	1.3	16.8	8.8	B
	Subtotal	440	400	91.0%	1.9	18.0	6.9	B
Total		1300	1192	91.7%	3.1	13.4	5.0	B

Intersection

Herman Street/Scott Street

Unsignalized

Direction	Movement	Volume (veh/hr)			GEH	Total Delay (sec/veh)		
		Demand	Served	% Served		Average	Std. Dev.	LOS
NB	Left Turn	10	10	95.0%	0.2	13.0	3.4	B
	Through	130	122	93.5%	0.8	14.8	1.6	B
	Right Turn	140	129	91.9%	1.0	10.4	1.5	B
	Subtotal	280	260	92.8%	1.2	12.5	1.3	B
SB	Left Turn	60	50	82.5%	1.4	17.7	2.7	C
	Through	200	190	95.0%	0.7	18.8	2.2	C
	Right Turn	10	10	97.0%	0.1	14.8	3.9	B
	Subtotal	270	249	92.3%	1.3	18.4	2.1	C
EB	Left Turn	10	8	84.0%	0.5	8.3	2.4	A
	Through	20	19	93.5%	0.3	11.5	2.4	B
	Right Turn	10	10	101.0%	0.0	7.5	2.6	A
	Subtotal	40	37	93.0%	0.5	9.7	1.5	A
WB	Left Turn	210	187	89.0%	1.6	0.2	0.0	A
	Through	30	27	88.7%	0.6	0.4	0.1	A
	Right Turn	30	29	97.7%	0.1	0.1	0.1	A
	Subtotal	270	243	90.0%	1.7	0.2	0.0	A
Total		860	789	91.7%	2.5	10.5	0.6	B

Intersection **Montgomery Avenue/Scott Street**

Unsignalized

Direction	Movement	Volume (veh/hr)			GEH	Total Delay (sec/veh)		
		Demand	Served	% Served		Average	Std. Dev.	LOS
NB	Left Turn	40	36	90.8%	0.6	8.0	1.4	A
	Through	10	10	95.0%	0.2	7.9	1.2	A
	Right Turn	20	18	90.5%	0.4	4.0	0.7	A
	Subtotal	70	64	91.3%	0.7	6.8	1.0	A
SB	Left Turn	10	9	91.0%	0.3	7.1	1.9	A
	Through	10	9	92.0%	0.3	8.8	1.6	A
	Right Turn	20	21	105.5%	0.2	4.3	0.7	A
	Subtotal	40	39	98.5%	0.1	6.0	0.8	A
EB	Left Turn	20	16	81.5%	0.9	2.5	0.7	A
	Through	170	154	90.3%	1.3	0.7	0.2	A
	Right Turn	30	28	93.7%	0.4	0.5	0.3	A
	Subtotal	220	198	90.0%	1.5	0.8	0.2	A
WB	Left Turn	20	17	87.0%	0.6	2.4	1.0	A
	Through	210	186	88.4%	1.7	0.6	0.2	A
	Right Turn	10	8	80.0%	0.7	0.4	0.5	A
	Subtotal	240	211	87.9%	1.9	0.7	0.3	A
Total		570	512	89.9%	2.5	1.9	0.2	A

Intersection **Driveway-Dollar Avenue/Linden Avenue**

Signalized

Direction	Movement	Volume (veh/hr)			GEH	Total Delay (sec/veh)		
		Demand	Served	% Served		Average	Std. Dev.	LOS
NB	Left Turn	100	90	89.7%	1.1	59.2	7.6	E
	Through							
	Right Turn	60	59	98.7%	0.1	53.4	9.6	D
	Subtotal	160	149	93.1%	0.9	56.8	7.2	E
SB	Left Turn	10	8	77.0%	0.8	65.8	14.3	E
	Through							
	Right Turn							
	Subtotal	10	8	77.0%	0.8	65.8	14.3	E
EB	Left Turn							
	Through	280	253	90.2%	1.7	79.8	8.8	E
	Right Turn	150	137	91.5%	1.1	70.2	10.4	E
	Subtotal	430	390	90.7%	2.0	76.4	8.8	E
WB	Left Turn	60	56	92.5%	0.6	6.8	3.2	A
	Through	300	280	93.2%	1.2	6.7	1.9	A
	Right Turn	10	9	90.0%	0.3	5.7	10.1	A
	Subtotal	370	344	93.0%	1.4	6.7	1.9	A
Total		970	891	91.8%	2.6	46.1	3.7	D

SimTraffic Post-Processor
Average Results from 20 Runs
Volume and Delay by Movement

Caltrain Electrification
2040 Plus Project Conditions
PM Peak Hour

Intersection

San Mateo Avenue/San Bruno Avenue

Signalized

Direction	Movement	Volume (veh/hr)			GEH	Total Delay (sec/veh)		
		Demand	Served	% Served		Average	Std. Dev.	LOS
NB	Left Turn	50	46	91.4%	0.6	76.6	24.4	E
	Through	120	115	96.1%	0.4	64.0	18.0	E
	Right Turn	200	200	100.1%	0.0	29.6	13.6	C
	Subtotal	370	361	97.6%	0.5	46.6	16.7	D
SB	Left Turn	130	126	97.2%	0.3	73.2	14.7	E
	Through	120	118	97.9%	0.2	63.9	15.2	E
	Right Turn	190	188	98.8%	0.2	53.0	12.4	D
	Subtotal	440	432	98.1%	0.4	61.8	13.7	E
EB	Left Turn	120	122	101.4%	0.2	17.2	3.0	B
	Through	530	530	99.9%	0.0	4.8	0.3	A
	Right Turn	30	32	106.7%	0.4	2.7	1.3	A
	Subtotal	680	683	100.5%	0.1	6.9	0.4	A
WB	Left Turn	140	144	102.9%	0.3	65.9	3.4	E
	Through	560	559	99.8%	0.0	25.2	1.9	C
	Right Turn	90	84	93.4%	0.6	22.1	2.7	C
	Subtotal	790	787	99.6%	0.1	32.4	2.1	C
Total		2280	2263	99.3%	0.4	32.5	3.7	C

Intersection El Camino Real/Millbrae Avenue

Signalized

Direction	Movement	Volume (veh/hr)			GEH	Total Delay (sec/veh)		
		Demand	Served	% Served		Average	Std. Dev.	LOS
NB	Left Turn	50	48	95.6%	0.3	84.5	17.3	F
	Through	1130	1053	93.2%	2.3	83.4	28.7	F
	Right Turn	710	654	92.1%	2.1	41.1	18.6	D
	Subtotal	1890	1755	92.8%	3.2	67.8	22.5	E
SB	Left Turn	670	463	69.1%	8.7	276.7	35.4	F
	Through	1730	1221	70.6%	13.3	59.8	4.4	E
	Right Turn	70	53	75.9%	2.2	63.5	5.2	E
	Subtotal	2470	1737	70.3%	16.0	117.8	10.9	F
EB	Left Turn	140	138	98.4%	0.2	175.9	58.3	F
	Through	580	568	97.8%	0.5	124.4	47.3	F
	Right Turn	50	52	104.8%	0.3	125.6	48.3	F
	Subtotal	770	758	98.4%	0.4	133.9	48.5	F
WB	Left Turn	650	566	87.1%	3.4	93.6	18.0	F
	Through	730	638	87.4%	3.5	44.7	3.2	D
	Right Turn	820	726	88.5%	3.4	22.1	1.7	C
	Subtotal	2200	1930	87.7%	5.9	50.6	6.0	D
Total		7330	6179	84.3%	14.0	84.7	11.4	F

Intersection Rollins Road/Millbrae Avenue

Signalized

Direction	Movement	Volume (veh/hr)			GEH	Total Delay (sec/veh)		
		Demand	Served	% Served		Average	Std. Dev.	LOS
NB	Left Turn	350	321	91.8%	1.6	60.7	3.3	E
	Through	110	91	82.3%	1.9	112.2	5.4	F
	Right Turn	740	641	86.6%	3.8	99.1	2.8	F
	Subtotal	1200	1053	87.7%	4.4	88.6	2.5	F
SB	Left Turn	460	470	102.2%	0.5	71.8	10.0	E
	Through	210	217	103.3%	0.5	63.5	7.1	E
	Right Turn	310	305	98.5%	0.3	30.1	11.2	C
	Subtotal	980	992	101.3%	0.4	57.3	6.8	E
EB	Left Turn	200	176	87.9%	1.8	246.0	45.0	F
	Through	1510	1275	84.4%	6.3	174.1	31.5	F
	Right Turn	250	206	82.4%	2.9	143.8	31.0	F
	Subtotal	1960	1657	84.5%	7.1	178.0	31.9	F
WB	Left Turn	420	338	80.4%	4.2	259.6	45.3	F
	Through	1540	1281	83.2%	6.9	194.2	14.5	F
	Right Turn	390	327	83.8%	3.3	11.5	2.3	B
	Subtotal	2350	1945	82.8%	8.7	175.3	8.4	F
Total		6490	5647	87.0%	10.8	139.5	10.0	F

SimTraffic Post-Processor
Average Results from 20 Runs
Volume and Delay by Movement

Caltrain Electrification
2040 Plus Project Conditions
PM Peak Hour

Intersection

California Drive/Oak Grove

Signalized

Direction	Movement	Volume (veh/hr)			GEH	Total Delay (sec/veh)		
		Demand	Served	% Served		Average	Std. Dev.	LOS
NB	Left Turn	170	156	91.6%	1.1	269.2	92.2	F
	Through	750	732	97.6%	0.7	107.5	28.1	F
	Right Turn	250	237	94.6%	0.9	76.4	25.0	E
	Subtotal	1170	1124	96.1%	1.3	123.6	28.2	F
SB	Left Turn	170	163	95.9%	0.5	205.7	46.1	F
	Through	800	787	98.4%	0.5	78.2	12.9	E
	Right Turn	90	87	96.7%	0.3	43.0	11.1	D
	Subtotal	1060	1037	97.9%	0.7	95.6	15.8	F
EB	Left Turn	30	30	100.3%	0.0	88.1	10.7	F
	Through	290	266	91.6%	1.5	107.3	14.4	F
	Right Turn	80	79	98.8%	0.1	91.8	10.4	F
	Subtotal	400	375	93.7%	1.3	102.5	12.8	F
WB	Left Turn	210	106	50.4%	8.3	28.9	2.4	C
	Through	160	86	53.5%	6.7	28.2	3.4	C
	Right Turn	240	128	53.3%	8.3	15.0	2.0	B
	Subtotal	610	319	52.3%	13.5	23.1	1.7	C
Total		3240	2856	88.1%	7.0	99.1	15.1	F

Intersection

Carolan Ave/Oak Grove

Unsignalized

Direction	Movement	Volume (veh/hr)			GEH	Total Delay (sec/veh)		
		Demand	Served	% Served		Average	Std. Dev.	LOS
NB	Left Turn	110	56	50.8%	5.9	625.2	67.4	F
	Through	130	71	54.5%	5.9	571.6	61.2	F
	Right Turn	50	25	49.8%	4.1	586.4	88.9	F
	Subtotal	290	152	52.3%	9.3	593.6	55.2	F
SB	Left Turn	160	82	51.2%	7.1	211.0	36.8	F
	Through	140	76	53.9%	6.2	217.7	38.8	F
	Right Turn	290	144	49.7%	9.9	453.3	73.0	F
	Subtotal	590	302	51.1%	13.7	329.5	22.5	F
EB	Left Turn	390	370	94.8%	1.0	0.5	0.0	A
	Through	130	133	102.2%	0.3	1.5	0.2	A
	Right Turn	190	178	93.6%	0.9	0.3	0.1	A
	Subtotal	710	681	95.8%	1.1	0.6	0.0	A
WB	Left Turn	90	41	45.6%	6.1	245.7	18.3	F
	Through	210	104	49.4%	8.5	258.7	21.1	F
	Right Turn	70	35	49.6%	4.9	243.9	17.4	F
	Subtotal	370	179	48.5%	11.5	252.8	18.8	F
Total		1960	1313	67.0%	16.0	178.3	6.8	F

SimTraffic Post-Processor
Average Results from 20 Runs
Volume and Delay by Movement

Caltrain Electrification
2040 Plus Project Conditions
PM Peak Hour

Intersection

California Dr/North Lane

Unsignalized

Direction	Movement	Volume (veh/hr)			GEH	Total Delay (sec/veh)		
		Demand	Served	% Served		Average	Std. Dev.	LOS
NB	Left Turn							
	Through	990	1008	101.8%	0.6	2.0	1.2	A
	Right Turn	120	121	100.6%	0.1	2.0	0.4	A
	Subtotal	1110	1128	101.6%	0.5	2.0	1.1	A
SB	Left Turn	160	136	84.8%	2.0	25.4	5.5	D
	Through	970	876	90.4%	3.1	5.6	1.0	A
	Right Turn							
	Subtotal	1130	1012	89.6%	3.6	8.3	1.2	A
EB	Left Turn							
	Through							
	Right Turn							
	Subtotal							
WB	Left Turn	60	50	83.5%	1.3	53.7	10.8	F
	Through							
	Right Turn	190	155	81.6%	2.7	10.7	6.1	B
	Subtotal	250	205	82.0%	3.0	21.4	6.4	C
Total		2490	2345	94.2%	2.9	6.4	1.2	A

Intersection

Carolan Ave/North Lane

Unsignalized

Direction	Movement	Volume (veh/hr)			GEH	Total Delay (sec/veh)		
		Demand	Served	% Served		Average	Std. Dev.	LOS
NB	Left Turn	140	132	94.4%	0.7	110.3	72.9	F
	Through	190	185	97.2%	0.4	43.1	32.1	E
	Right Turn	10	10	100.0%	0.0	25.9	24.8	D
	Subtotal	340	327	96.1%	0.7	69.4	47.1	F
SB	Left Turn	20	13	63.5%	1.8	49.7	40.4	E
	Through	270	204	75.7%	4.3	52.7	32.6	F
	Right Turn	110	74	67.6%	3.7	67.5	56.6	F
	Subtotal	400	291	72.9%	5.8	56.5	38.6	F
EB	Left Turn	90	79	87.9%	1.2	0.9	0.3	A
	Through	10	19	191.0%	2.4	0.9	0.2	A
	Right Turn	180	166	92.2%	1.1	0.6	0.1	A
	Subtotal	280	264	94.3%	1.0	0.7	0.1	A
WB	Left Turn							
	Through							
	Right Turn							
	Subtotal							
Total		1020	882	86.5%	4.5	44.4	29.2	E

Intersection Anita Road/Peninsula Avenue

Unsignalized

Direction	Movement	Volume (veh/hr)			GEH	Total Delay (sec/veh)		
		Demand	Served	% Served		Average	Std. Dev.	LOS
NB	Left Turn							
	Through							
	Right Turn							
	Subtotal							
SB	Left Turn	20	20	98.0%	0.1	31.3	23.5	D
	Through							
	Right Turn	10	11	114.0%	0.4	43.5	34.1	E
	Subtotal	30	31	103.3%	0.2	36.1	27.5	E
EB	Left Turn	20	20	101.0%	0.0	13.7	2.9	B
	Through	660	655	99.2%	0.2	0.8	0.3	A
	Right Turn							
	Subtotal	680	675	99.3%	0.2	1.2	0.4	A
WB	Left Turn							
	Through	700	699	99.9%	0.0	14.5	1.7	B
	Right Turn	30	29	95.3%	0.3	12.1	5.1	B
	Subtotal	730	728	99.7%	0.1	14.4	1.7	B
Total		1440	1434	99.6%	0.2	8.6	1.4	A

Intersection Woodside Way/Villa Terrace

Unsignalized

Direction	Movement	Volume (veh/hr)			GEH	Total Delay (sec/veh)		
		Demand	Served	% Served		Average	Std. Dev.	LOS
NB	Left Turn	10	11	109.0%	0.3	4.6	0.4	A
	Through	20	22	110.0%	0.4	5.8	0.2	A
	Right Turn	10	10	95.0%	0.2	2.9	0.6	A
	Subtotal	40	42	106.0%	0.4	4.8	0.3	A
SB	Left Turn	20	20	100.5%	0.0	5.7	0.8	A
	Through	50	49	97.8%	0.2	7.1	0.2	A
	Right Turn	60	57	95.3%	0.4	3.6	0.4	A
	Subtotal	130	126	97.1%	0.3	5.3	0.2	A
EB	Left Turn	30	28	94.0%	0.3	2.7	0.3	A
	Through	30	30	99.7%	0.0	2.3	0.4	A
	Right Turn	20	18	89.5%	0.5	1.3	0.2	A
	Subtotal	80	76	95.0%	0.5	2.2	0.2	A
WB	Left Turn	10	10	102.0%	0.1	2.1	0.5	A
	Through	30	28	92.7%	0.4	0.5	0.2	A
	Right Turn	20	22	108.5%	0.4	0.2	0.1	A
	Subtotal	60	60	99.5%	0.0	0.7	0.2	A
Total		310	304	98.2%	0.3	3.5	0.2	A

Intersection N. San Mateo Drive/Villa Terrace

Unsignalized

Direction	Movement	Volume (veh/hr)			GEH	Total Delay (sec/veh)		
		Demand	Served	% Served		Average	Std. Dev.	LOS
NB	Left Turn	10	9	91.0%	0.3	5.8	2.2	A
	Through	600	602	100.3%	0.1	0.6	0.1	A
	Right Turn	50	47	94.8%	0.4	0.7	0.1	A
	Subtotal	660	658	99.7%	0.1	0.7	0.1	A
SB	Left Turn	20	18	90.5%	0.4	6.5	1.1	A
	Through	530	542	102.2%	0.5	3.3	0.2	A
	Right Turn	20	22	110.0%	0.4	3.7	0.9	A
	Subtotal	570	582	102.1%	0.5	3.4	0.2	A
EB	Left Turn	10	10	104.0%	0.1	13.0	4.2	B
	Through	10	10	104.0%	0.1	15.2	4.4	C
	Right Turn	20	20	101.5%	0.1	6.0	1.5	A
	Subtotal	40	41	102.8%	0.2	10.2	2.3	B
WB	Left Turn	40	41	103.3%	0.2	19.1	2.7	C
	Through	20	18	91.0%	0.4	19.3	6.0	C
	Right Turn	40	37	93.5%	0.4	11.8	1.9	B
	Subtotal	100	97	96.9%	0.3	16.2	2.0	C
Total		1370	1378	100.6%	0.2	3.2	0.2	A

Intersection Arundel Road/Peninsula Avenue

Unsignalized

Direction	Movement	Volume (veh/hr)			GEH	Total Delay (sec/veh)		
		Demand	Served	% Served		Average	Std. Dev.	LOS
NB	Left Turn	20	22	109.5%	0.4	44.7	10.7	E
	Through	10	11	105.0%	0.2	35.0	17.9	D
	Right Turn	40	40	99.3%	0.0	20.9	7.8	C
	Subtotal	70	72	103.0%	0.2	30.2	9.3	D
SB	Left Turn	20	20	99.0%	0.0	31.0	7.8	D
	Through	10	9	90.0%	0.3	29.6	9.3	D
	Right Turn	20	18	91.0%	0.4	18.1	9.1	C
	Subtotal	50	47	94.0%	0.4	25.8	7.8	D
EB	Left Turn	10	9	85.0%	0.5	7.9	3.2	A
	Through	610	606	99.3%	0.2	1.1	0.1	A
	Right Turn	60	62	102.8%	0.2	0.9	0.2	A
	Subtotal	680	676	99.4%	0.2	1.1	0.2	A
WB	Left Turn	60	54	90.5%	0.8	14.2	3.3	B
	Through	690	686	99.5%	0.1	10.7	2.8	B
	Right Turn	30	30	98.7%	0.1	8.7	3.6	A
	Subtotal	780	770	98.8%	0.3	10.9	2.8	B
Total		1580	1565	99.1%	0.4	8.0	1.5	A

Intersection **Railroad Ave/1st Ave**

Unsignalized

Direction	Movement	Volume (veh/hr)			GEH	Total Delay (sec/veh)		
		Demand	Served	% Served		Average	Std. Dev.	LOS
NB	Left Turn	30	27	88.3%	0.7	62.7	22.1	F
	Through	20	22	109.5%	0.4	42.9	18.7	E
	Right Turn	20	19	93.0%	0.3	35.8	21.1	E
	Subtotal	70	67	95.7%	0.4	48.5	19.1	E
SB	Left Turn							
	Through							
	Right Turn							
	Subtotal							
EB	Left Turn	10	8	78.0%	0.7	3.6	2.0	A
	Through	410	311	75.7%	5.2	0.8	0.2	A
	Right Turn							
	Subtotal	420	318	75.8%	5.3	0.9	0.2	A
WB	Left Turn							
	Through	340	217	63.7%	7.4	168.2	26.1	F
	Right Turn	10	7	67.0%	1.1	155.4	101.3	F
	Subtotal	350	223	63.8%	7.5	168.0	26.9	F
Total		840	609	72.5%	8.6	66.8	8.8	F

Intersection **S. B. St/1st Ave**

Signalized

Direction	Movement	Volume (veh/hr)			GEH	Total Delay (sec/veh)		
		Demand	Served	% Served		Average	Std. Dev.	LOS
NB	Left Turn	100	82	82.4%	1.8	66.4	10.7	E
	Through	520	445	85.6%	3.4	56.5	6.0	E
	Right Turn	80	65	80.9%	1.8	56.6	11.1	E
	Subtotal	700	592	84.6%	4.2	57.9	5.3	E
SB	Left Turn	90	70	78.0%	2.2	61.5	6.7	E
	Through	500	379	75.8%	5.8	45.8	4.0	D
	Right Turn	50	39	78.0%	1.6	44.5	5.1	D
	Subtotal	640	488	76.3%	6.4	47.9	3.6	D
EB	Left Turn	20	14	69.5%	1.5	1457.1	411.5	F
	Through	270	178	65.7%	6.2	1414.3	171.2	F
	Right Turn	70	49	69.3%	2.8	1424.9	229.0	F
	Subtotal	360	240	66.6%	6.9	1413.0	170.3	F
WB	Left Turn	60	41	67.5%	2.8	62.5	8.6	E
	Through	180	137	76.2%	3.4	51.3	5.5	D
	Right Turn	100	72	72.0%	3.0	43.6	6.2	D
	Subtotal	340	250	73.4%	5.3	50.9	5.1	D
Total		2040	1570	77.0%	11.1	260.1	23.8	F

SimTraffic Post-Processor
Average Results from 20 Runs
Volume and Delay by Movement

Caltrain Electrification
2040 Plus Project Conditions
PM Peak Hour

Intersection

Transit Center Way/1st St

Unsignalized

Direction	Movement	Volume (veh/hr)			GEH	Total Delay (sec/veh)		
		Demand	Served	% Served		Average	Std. Dev.	LOS
NB	Left Turn	70	58	82.1%	1.6	93.8	14.3	F
	Through	20	20	102.0%	0.1	57.2	8.1	F
	Right Turn	70	63	90.4%	0.8	51.6	4.7	F
	Subtotal	160	141	88.3%	1.5	69.3	6.8	F
SB	Left Turn							
	Through							
	Right Turn							
	Subtotal							
EB	Left Turn	80	57	71.0%	2.8	17.1	3.6	C
	Through	350	259	74.1%	5.2	9.7	1.3	A
	Right Turn	10	7	68.0%	1.1	10.7	5.1	B
	Subtotal	440	323	73.4%	6.0	11.0	0.9	B
WB	Left Turn							
	Through	270	186	69.0%	5.5	28.9	4.5	D
	Right Turn	100	66	66.0%	3.7	13.6	3.5	B
	Subtotal	370	252	68.2%	6.7	25.0	3.9	C
Total		970	717	73.9%	8.7	27.3	2.8	D

Intersection **Railroad Avenue/9th Avenue**

Unsignalized

Direction	Movement	Volume (veh/hr)			GEH	Total Delay (sec/veh)		
		Demand	Served	% Served		Average	Std. Dev.	LOS
NB	Left Turn	50	44	87.0%	1.0	105.6	36.5	F
	Through							
	Right Turn	70	70	99.7%	0.0	83.0	36.1	F
	Subtotal	120	113	94.4%	0.6	91.6	35.7	F
SB	Left Turn							
	Through							
	Right Turn							
	Subtotal							
EB	Left Turn							
	Through	640	579	90.4%	2.5	1.9	0.2	A
	Right Turn	80	77	95.8%	0.4	0.5	0.2	A
	Subtotal	720	655	91.0%	2.5	1.8	0.2	A
WB	Left Turn	10	10	99.0%	0.0	32.0	14.3	D
	Through	620	620	100.0%	0.0	24.7	6.7	C
	Right Turn							
	Subtotal	630	630	100.0%	0.0	24.9	6.7	C
Total		1470	1399	95.2%	1.9	19.6	3.0	C

Intersection **S B Street/9th Avenue**

Signalized

Direction	Movement	Volume (veh/hr)			GEH	Total Delay (sec/veh)		
		Demand	Served	% Served		Average	Std. Dev.	LOS
NB	Left Turn	10	10	97.0%	0.1	37.5	10.1	D
	Through	270	273	101.0%	0.2	31.1	4.7	C
	Right Turn	170	161	94.5%	0.7	27.9	5.4	C
	Subtotal	450	443	98.5%	0.3	30.1	4.9	C
SB	Left Turn	110	100	90.5%	1.0	102.5	28.9	F
	Through	190	200	105.2%	0.7	35.6	14.9	D
	Right Turn	90	92	102.0%	0.2	28.7	14.0	C
	Subtotal	390	391	100.3%	0.1	51.2	19.1	D
EB	Left Turn	50	45	89.6%	0.8	197.3	29.6	F
	Through	440	394	89.5%	2.3	185.1	26.3	F
	Right Turn	20	19	97.0%	0.1	175.5	34.1	F
	Subtotal	510	458	89.8%	2.4	185.9	26.4	F
WB	Left Turn	130	122	93.8%	0.7	46.8	7.0	D
	Through	400	402	100.5%	0.1	21.8	2.0	C
	Right Turn	140	133	94.7%	0.6	16.8	1.8	B
	Subtotal	670	656	98.0%	0.5	25.5	2.6	C
Total		2020	1949	96.5%	1.6	69.3	5.9	E

Intersection Concar Drive/SR 92 WB Ramps

Signalized

Direction	Movement	Volume (veh/hr)			GEH	Total Delay (sec/veh)		
		Demand	Served	% Served		Average	Std. Dev.	LOS
NB	Left Turn	290	281	96.9%	0.5	21.3	1.0	C
	Through	50	50	99.4%	0.0	15.3	3.0	B
	Right Turn							
	Subtotal	340	331	97.2%	0.5	20.4	1.0	C
SB	Left Turn	30	28	93.3%	0.4	14.6	1.9	B
	Through	60	60	99.5%	0.0	12.7	0.9	B
	Right Turn	10	11	109.0%	0.3	5.2	2.4	A
	Subtotal	100	99	98.6%	0.1	12.4	0.9	B
EB	Left Turn	10	9	92.0%	0.3	29.2	7.2	C
	Through	70	70	99.7%	0.0	30.3	4.2	C
	Right Turn	40	44	109.0%	0.6	15.4	3.1	B
	Subtotal	120	123	102.2%	0.2	24.9	3.9	C
WB	Left Turn	700	691	98.6%	0.4	7.4	0.6	A
	Through	90	88	98.2%	0.2	8.5	1.0	A
	Right Turn	50	56	111.2%	0.8	2.3	0.7	A
	Subtotal	840	835	99.3%	0.2	7.1	0.7	A
Total		1400	1386	99.0%	0.4	12.3	0.9	B

Intersection Delaware Ave/25th Ave

Signalized

Direction	Movement	Volume (veh/hr)			GEH	Total Delay (sec/veh)		
		Demand	Served	% Served		Average	Std. Dev.	LOS
NB	Left Turn	70	31	43.9%	5.5	1738.7	674.9	F
	Through	10	10	96.0%	0.1	91.5	101.4	F
	Right Turn							
	Subtotal	80	40	50.4%	5.1	1344.7	518.4	F
SB	Left Turn							
	Through	10	9	85.0%	0.5	35.8	27.6	D
	Right Turn	860	708	82.3%	5.4	160.9	18.0	F
	Subtotal	870	717	82.4%	5.4	159.4	18.0	F
EB	Left Turn	760	633	83.3%	4.8	29.1	2.0	C
	Through							
	Right Turn	40	35	86.3%	0.9	13.8	4.3	B
	Subtotal	800	668	83.5%	4.9	28.3	2.0	C
WB	Left Turn							
	Through							
	Right Turn							
	Subtotal							
Total		1750	1425	81.4%	8.2	128.0	10.8	F

Intersection El Camino Real/25th Ave

Signalized

Direction	Movement	Volume (veh/hr)			GEH	Total Delay (sec/veh)		
		Demand	Served	% Served		Average	Std. Dev.	LOS
NB	Left Turn	100	95	95.0%	0.5	121.6	8.7	F
	Through	1990	1844	92.6%	3.3	98.8	3.8	F
	Right Turn	350	326	93.2%	1.3	118.0	4.0	F
	Subtotal	2440	2265	92.8%	3.6	102.5	3.7	F
SB	Left Turn	250	205	82.1%	3.0	474.1	44.7	F
	Through	1750	1503	85.9%	6.1	231.3	23.4	F
	Right Turn	360	297	82.6%	3.5	231.9	20.3	F
	Subtotal	2360	2005	85.0%	7.6	256.2	24.0	F
EB	Left Turn	230	170	73.7%	4.3	353.2	14.1	F
	Through	200	148	74.2%	3.9	375.8	15.4	F
	Right Turn	150	120	79.9%	2.6	297.0	14.6	F
	Subtotal	580	438	75.5%	6.3	345.5	14.4	F
WB	Left Turn	480	368	76.8%	5.4	101.3	5.7	F
	Through	200	142	70.8%	4.5	112.9	2.3	F
	Right Turn	320	246	76.9%	4.4	57.5	3.5	E
	Subtotal	1000	756	75.6%	8.2	89.3	3.3	F
Total		6380	5464	85.6%	11.9	176.5	8.4	F

Intersection El Camino Real/31st Street

Signalized

Direction	Movement	Volume (veh/hr)			GEH	Total Delay (sec/veh)		
		Demand	Served	% Served		Average	Std. Dev.	LOS
NB	Left Turn	170	117	68.8%	4.4	92.7	16.6	F
	Through	2050	1404	68.5%	15.6	45.5	4.2	D
	Right Turn	20	14	72.0%	1.4	13.0	7.4	B
	Subtotal	2240	1535	68.5%	16.2	48.8	4.3	D
SB	Left Turn	340	269	79.2%	4.1	181.8	25.4	F
	Through	2340	1914	81.8%	9.2	215.1	79.1	F
	Right Turn	170	141	82.6%	2.4	202.3	98.8	F
	Subtotal	2850	2324	81.5%	10.4	210.1	71.7	F
EB	Left Turn	260	238	91.4%	1.4	117.2	106.8	F
	Through	40	38	95.3%	0.3	169.4	234.4	F
	Right Turn	180	176	97.5%	0.3	51.0	142.5	D
	Subtotal	480	451	94.0%	1.3	95.3	128.4	F
WB	Left Turn	100	96	95.6%	0.4	52.8	42.1	D
	Through	40	36	89.3%	0.7	61.8	61.6	E
	Right Turn	20	19	95.5%	0.2	27.5	32.1	C
	Subtotal	160	150	94.0%	0.8	51.1	43.3	D
Total		5730	4460	77.8%	17.8	136.7	49.1	F

Intersection El Camino Real/Hillsdale Blvd

Signalized

Direction	Movement	Volume (veh/hr)			GEH	Total Delay (sec/veh)		
		Demand	Served	% Served		Average	Std. Dev.	LOS
NB	Left Turn							
	Through							
	Right Turn							
	Subtotal							
SB	Left Turn	720	597	83.0%	4.8	92.3	101.7	F
	Through							
	Right Turn	240	195	81.3%	3.1	40.7	3.8	D
	Subtotal	960	792	82.5%	5.7	78.3	72.8	E
EB	Left Turn							
	Through	1020	614	60.2%	14.2	110.4	50.1	F
	Right Turn	130	76	58.5%	5.3	50.2	21.4	D
	Subtotal	1150	690	60.0%	15.2	103.8	46.9	F
WB	Left Turn	330	182	55.2%	9.2	18.7	7.1	B
	Through	1180	645	54.7%	17.7	30.4	13.8	C
	Right Turn							
	Subtotal	1510	828	54.8%	20.0	27.8	12.0	C
Total		4460	2793	62.6%	27.7	194.0	43.4	F

SimTraffic Post-Processor
Average Results from 20 Runs
Volume and Delay by Movement

Caltrain Electrification
2040 Plus Project Conditions
PM Peak Hour

Intersection

Curtiss Street/Hillsdale Blvd

Signalized

Direction	Movement	Volume (veh/hr)			GEH	Total Delay (sec/veh)		
		Demand	Served	% Served		Average	Std. Dev.	LOS
NB	Left Turn	80	73	91.0%	0.8	151.6	201.2	F
	Through	30	31	102.7%	0.1	142.0	164.7	F
	Right Turn	100	98	97.5%	0.3	90.8	186.5	F
	Subtotal	210	201	95.8%	0.6	120.7	188.9	F
SB	Left Turn	40	34	84.8%	1.0	125.1	185.4	F
	Through	10	8	84.0%	0.5	138.0	207.4	F
	Right Turn	30	31	102.7%	0.1	136.1	245.1	F
	Subtotal	80	73	91.4%	0.8	128.0	203.9	F
EB	Left Turn	10	6	61.0%	1.4	28.3	16.3	C
	Through	1360	942	69.3%	12.3	3.9	0.7	A
	Right Turn	150	99	66.2%	4.5	2.7	0.2	A
	Subtotal	1520	1048	68.9%	13.2	3.9	0.8	A
WB	Left Turn	10	4	40.0%	2.3	238.0	43.2	F
	Through	1620	795	49.1%	23.7	253.3	93.0	F
	Right Turn	40	20	49.8%	3.7	259.0	93.6	F
	Subtotal	1670	819	49.0%	24.1	253.4	92.7	F
Total		3480	2141	61.5%	25.3	115.2	63.5	F

SimTraffic Post-Processor
Average Results from 20 Runs
Volume and Delay by Movement

Caltrain Electrification
2040 Plus Project Conditions
PM Peak Hour

Intersection

El Camino Real/Ralston Avenue

Signalized

Direction	Movement	Volume (veh/hr)			GEH	Total Delay (sec/veh)		
		Demand	Served	% Served		Average	Std. Dev.	LOS
NB	Left Turn	100	68	68.0%	3.5	264.9	16.9	F
	Through	1190	930	78.1%	8.0	205.4	3.7	F
	Right Turn	230	172	74.7%	4.1	36.9	2.6	D
	Subtotal	1520	1169	76.9%	9.6	184.2	2.1	F
SB	Left Turn	450	265	58.9%	9.8	398.1	9.0	F
	Through	1250	768	61.5%	15.2	76.9	3.4	E
	Right Turn	150	89	59.5%	5.6	33.0	2.6	C
	Subtotal	1850	1122	60.7%	18.9	149.3	3.6	F
EB	Left Turn	280	191	68.1%	5.8	231.3	8.2	F
	Through	900	630	70.0%	9.8	264.2	6.0	F
	Right Turn	80	54	67.1%	3.2	282.8	16.8	F
	Subtotal	1260	874	69.4%	11.8	258.2	5.9	F
WB	Left Turn	290	247	85.1%	2.6	83.8	5.7	F
	Through	890	751	84.4%	4.8	210.1	8.2	F
	Right Turn	370	321	86.9%	2.6	45.6	6.6	D
	Subtotal	1550	1320	85.1%	6.1	146.5	6.6	F
Total		6180	4486	72.6%	23.2	178.7	2.2	F

SimTraffic Post-Processor
Average Results from 10 Runs
Volume and Delay by Movement

Caltrain Electrification
2040 Plus Project Conditions
PM Peak Hour

Intersection

El Camino Real/San Carlos Avenue-Caltrain Station

Signalized

Direction	Movement	Volume (veh/hr)			GEH	Total Delay (sec/veh)		
		Demand	Served	% Served		Average	Std. Dev.	LOS
NB	Left Turn	230	225	97.9%	0.3	90.5	29.0	F
	Through	1060	1041	98.2%	0.6	23.6	0.9	C
	Right Turn	20	22	109.5%	0.4	23.5	5.2	C
	Subtotal	1310	1288	98.4%	0.6	35.5	5.6	D
SB	Left Turn	60	53	88.2%	0.9	75.6	5.1	E
	Through	1240	1122	90.5%	3.4	67.9	1.9	E
	Right Turn	410	363	88.6%	2.4	44.4	1.7	D
	Subtotal	1710	1539	90.0%	4.3	62.6	2.0	E
EB	Left Turn	390	377	96.6%	0.7	33.2	1.8	C
	Through	100	110	109.5%	0.9	40.2	3.6	D
	Right Turn	180	184	102.3%	0.3	30.1	2.9	C
	Subtotal	670	671	100.1%	0.0	33.5	1.7	C
WB	Left Turn	20	21	106.0%	0.3	63.3	6.7	E
	Through	20	19	96.0%	0.2	48.6	7.6	D
	Right Turn	30	30	100.3%	0.0	18.2	3.9	B
	Subtotal	70	71	100.7%	0.1	40.0	4.5	D
Total		3760	3568	94.9%	3.2	46.9	2.1	D

Intersection **California/Broadway** Unsignalized

Direction	Movement	Volume (veh/hr)			GEH	Total Delay (sec/veh)		
		Demand	Served	% Served		Average	Std. Dev.	LOS
NB	Left Turn	50	9	18.6%	7.5	1383.3	339.6	F
	Through	90	13	14.3%	10.7	1301.4	314.3	F
	Right Turn	230	35	15.0%	17.0	1337.4	204.7	F
	Subtotal	370	57	15.4%	21.4	1335.0	223.6	F
SB	Left Turn	120	23	18.8%	11.5	283.8	55.6	F
	Through	110	21	19.5%	10.9	224.5	52.2	F
	Right Turn	60	13	22.0%	7.7	213.3	56.4	F
	Subtotal	290	57	19.7%	17.7	242.8	41.2	F
EB	Left Turn	40	11	27.3%	5.8	161.6	32.9	F
	Through	1090	257	23.6%	32.1	164.2	19.2	F
	Right Turn	200	47	23.7%	13.7	159.9	41.7	F
	Subtotal	1330	316	23.7%	35.4	163.4	21.7	F
WB	Left Turn	360	85	23.6%	18.5	13.6	2.0	B
	Through	1090	254	23.3%	32.3	5.9	1.0	A
	Right Turn	140	33	23.4%	11.5	0.5	0.5	A
	Subtotal	1590	371	23.3%	38.9	7.2	0.8	A
Total		3580	801	22.4%	59.4	179.6	28.2	F

Intersection **Arguello Street/Brewster Ave** Signalized

Direction	Movement	Volume (veh/hr)			GEH	Total Delay (sec/veh)		
		Demand	Served	% Served		Average	Std. Dev.	LOS
NB	Left Turn	150	36	23.9%	11.8	83.6	15.7	F
	Through	650	160	24.6%	24.4	63.3	12.5	E
	Right Turn	150	38	25.3%	11.6	24.4	14.3	C
	Subtotal	950	233	24.6%	29.5	60.2	12.3	E
SB	Left Turn	30	13	44.0%	3.6	363.5	41.9	F
	Through	460	194	42.1%	14.7	385.2	40.0	Fa
	Right Turn	210	89	42.3%	9.9	370.9	34.3	F
	Subtotal	700	296	42.2%	18.1	380.0	37.5	F
EB	Left Turn	110	91	82.5%	1.9	10.0	3.2	A
	Through	200	168	84.2%	2.3	7.7	1.1	A
	Right Turn	40	33	82.8%	1.1	1.5	0.8	A
	Subtotal	350	292	83.5%	3.2	7.7	0.6	A
WB	Left Turn	60	63	105.0%	0.4	50.3	5.4	D
	Through	450	460	102.3%	0.5	50.1	2.0	D
	Right Turn	50	49	97.6%	0.2	43.0	6.7	D
	Subtotal	560	572	102.2%	0.5	49.5	1.7	D
Total		2560	1393	54.4%	26.2	112.1	3.4	F

Intersection

El Camino Real/Broadway

Signalized

Direction	Movement	Volume (veh/hr)			GEH	Total Delay (sec/veh)		
		Demand	Served	% Served		Average	Std. Dev.	LOS
NB	Left Turn	220	153	69.6%	4.9	172.8	15.7	F
	Through	1280	927	72.4%	10.6	127.4	6.4	F
	Right Turn	150	103	68.8%	4.2	125.1	20.2	F
	Subtotal	1650	1183	71.7%	12.4	133.2	6.4	F
SB	Left Turn	550	107	19.5%	24.4	552.3	87.7	F
	Through	1250	269	21.5%	35.6	44.4	6.5	D
	Right Turn	30	7	22.7%	5.4	13.8	8.1	B
	Subtotal	1830	383	20.9%	43.5	185.1	18.7	F
EB	Left Turn	20	3	14.0%	5.1	696.8	298.1	F
	Through	630	100	15.8%	27.8	718.1	136.3	F
	Right Turn	300	49	16.2%	19.1	591.1	121.8	F
	Subtotal	950	151	15.9%	34.0	676.4	133.6	F
WB	Left Turn	180	43	23.8%	13.0	54.7	4.7	D
	Through	890	210	23.6%	29.0	59.0	3.9	E
	Right Turn	130	30	23.4%	11.1	52.7	4.1	D
	Subtotal	1200	284	23.6%	33.7	57.6	3.5	E
Total		5630	2001	35.5%	58.8	172.8	10.5	F

Intersection

Arguello St/Broadway

Signalized

Direction	Movement	Volume (veh/hr)			GEH	Total Delay (sec/veh)		
		Demand	Served	% Served		Average	Std. Dev.	LOS
NB	Left Turn	80	28	35.1%	7.1	278.4	66.9	F
	Through	220	90	40.7%	10.5	240.0	31.3	F
	Right Turn	360	150	41.6%	13.2	227.5	33.7	F
	Subtotal	660	267	40.5%	18.2	237.2	31.8	F
SB	Left Turn	90	46	51.6%	5.3	120.4	42.8	F
	Through	260	136	52.3%	8.8	99.7	35.2	F
	Right Turn	210	105	49.9%	8.4	70.6	29.5	E
	Subtotal	560	287	51.3%	13.3	92.4	34.2	F
EB	Left Turn	400	87	21.7%	20.1	18.4	3.2	B
	Through	940	216	22.9%	30.1	19.4	0.9	B
	Right Turn	100	22	21.8%	10.0	3.7	2.1	A
	Subtotal	1440	324	22.5%	37.6	18.1	0.7	B
WB	Left Turn	30	6	21.0%	5.6	301.3	64.3	F
	Through	1300	225	17.3%	38.9	245.2	17.7	F
	Right Turn	330	51	15.4%	20.2	112.4	12.1	F
	Subtotal	1660	282	17.0%	44.2	222.6	15.5	F
Total		4320	1160	26.9%	60.4	136.0	13.0	F

Intersection

El Camino Real/James

Signalized

Direction	Movement	Volume (veh/hr)			GEH	Total Delay (sec/veh)		
		Demand	Served	% Served		Average	Std. Dev.	LOS
NB	Left Turn	137	93	67.8%	4.1	235.8	13.2	F
	Through	1558	1059	68.0%	13.8	237.2	12.5	F
	Right Turn	42	29	69.8%	2.1	147.7	8.1	F
	Subtotal	1737	1181	68.0%	14.6	234.9	12.1	F
SB	Left Turn	137	28	20.1%	12.1	65.3	14.1	E
	Through	1600	328	20.5%	41.0	18.1	2.5	B
	Right Turn	84	18	21.3%	9.3	6.7	1.5	A
	Subtotal	1821	373	20.5%	43.7	21.0	2.9	C
EB	Left Turn	95	89	93.2%	0.7	92.9	14.7	F
	Through	63	60	94.8%	0.4	26.9	3.3	C
	Right Turn	105	104	98.9%	0.1	5.8	2.5	A
	Subtotal	263	252	95.8%	0.7	41.3	7.0	D
WB	Left Turn	211	52	24.6%	13.9	34.4	7.5	C
	Through	411	102	24.8%	19.3	37.4	2.1	D
	Right Turn	84	22	26.3%	8.5	63.6	23.3	E
	Subtotal	706	176	24.9%	25.2	39.6	4.0	D
Total		4527	1982	43.8%	44.6	152.5	4.9	F

Intersection

El Camino Real/Atherton Avenue-Fair Oaks Lane

Signalized

Direction	Movement	Volume (veh/hr)			GEH	Total Delay (sec/veh)		
		Demand	Served	% Served		Average	Std. Dev.	LOS
NB	Left Turn	310	238	76.7%	4.4	471.7	104.6	F
	Through	1910	1730	90.6%	4.2	36.1	4.4	D
	Right Turn	80	78	97.0%	0.3	32.8	5.0	C
	Subtotal	2300	2045	88.9%	5.5	86.7	14.7	F
SB	Left Turn	50	50	100.0%	0.0	108.0	34.8	F
	Through	1680	1637	97.4%	1.1	118.9	44.7	F
	Right Turn	80	75	93.4%	0.6	133.0	44.5	F
	Subtotal	1810	1761	97.3%	1.2	119.2	44.3	F
EB	Left Turn	140	142	101.4%	0.2	77.9	24.7	E
	Through	100	103	102.7%	0.3	75.9	24.0	E
	Right Turn	160	154	96.1%	0.5	57.7	22.5	E
	Subtotal	400	399	99.6%	0.1	69.6	23.5	E
WB	Left Turn	40	38	95.0%	0.3	209.7	120.3	F
	Through	120	118	98.7%	0.1	216.3	114.7	F
	Right Turn	80	82	103.0%	0.3	140.3	103.1	F
	Subtotal	240	239	99.5%	0.1	189.1	112.3	F
Total		4750	4444	93.6%	4.5	103.5	12.7	F

Intersection

El Camino Real/Watkins Avenue

Unsignalized

Direction	Movement	Volume (veh/hr)			GEH	Total Delay (sec/veh)		
		Demand	Served	% Served		Average	Std. Dev.	LOS
NB	Left Turn							
	Through	2100	2045	97.4%	1.2	9.8	9.1	A
	Right Turn	80	78	97.5%	0.2	6.3	7.8	A
	Subtotal	2180	2123	97.4%	1.2	9.7	9.0	A
SB	Left Turn	40	35	86.8%	0.9	61.7	20.4	F
	Through	1840	1789	97.2%	1.2	5.6	0.2	A
	Right Turn							
	Subtotal	1880	1824	97.0%	1.3	6.7	0.4	A
EB	Left Turn							
	Through							
	Right Turn							
	Subtotal							
WB	Left Turn	80	17	21.4%	9.0	2261.7	1117.5	F
	Through							
	Right Turn	200	45	22.4%	14.0	2138.8	902.4	F
	Subtotal	280	62	22.1%	16.7	2175.2	977.7	F
Total		4340	4008	92.4%	5.1	37.7	5.5	E

Intersection

El Camino Real/Glenwood

Signalized

Direction	Movement	Volume (veh/hr)			GEH	Total Delay (sec/veh)		
		Demand	Served	% Served		Average	Std. Dev.	LOS
NB	Left Turn	200	157	78.7%	3.2	54.9	19.6	D
	Through	1550	1231	79.4%	8.6	32.3	20.6	C
	Right Turn	50	36	71.4%	2.2	29.3	21.8	C
	Subtotal	1800	1424	79.1%	9.4	34.7	20.4	C
SB	Left Turn	280	237	84.7%	2.7	322.9	39.5	F
	Through	1220	1033	84.7%	5.6	188.3	12.6	F
	Right Turn	380	319	83.9%	3.3	135.5	15.8	F
	Subtotal	1880	1589	84.5%	7.0	198.1	13.0	F
EB	Left Turn	430	292	67.9%	7.3	1284.2	146.9	F
	Through	130	85	65.2%	4.4	1253.1	136.1	F
	Right Turn	120	85	71.2%	3.4	1192.4	168.2	F
	Subtotal	680	462	67.9%	9.1	1260.4	144.3	F
WB	Left Turn	90	68	75.9%	2.4	857.8	274.4	F
	Through	250	194	77.5%	3.8	875.1	258.0	F
	Right Turn	110	82	74.1%	2.9	848.1	266.5	F
	Subtotal	450	344	76.3%	5.3	865.2	262.8	F
Total		4810	3818	79.4%	15.1	325.3	38.7	F

Intersection

El Camino Real/Oak Grove

Signalized

Direction	Movement	Volume (veh/hr)			GEH	Total Delay (sec/veh)		
		Demand	Served	% Served		Average	Std. Dev.	LOS
NB	Left Turn	120	93	77.5%	2.6	35.7	1.7	D
	Through	1540	1234	80.1%	8.2	14.4	5.5	B
	Right Turn	110	91	82.4%	1.9	10.9	4.1	B
	Subtotal	1770	1418	80.1%	8.8	15.6	5.0	B
SB	Left Turn	340	264	77.5%	4.4	177.0	57.0	F
	Through	990	824	83.3%	5.5	61.6	14.0	E
	Right Turn	100	87	87.2%	1.3	22.2	6.9	C
	Subtotal	1430	1175	82.2%	7.1	84.8	21.9	F
EB	Left Turn	130	117	89.9%	1.2	305.9	169.0	F
	Through	250	217	86.7%	2.2	316.6	164.7	F
	Right Turn	150	133	88.7%	1.4	289.0	163.6	F
	Subtotal	530	467	88.1%	2.8	305.9	165.4	F
WB	Left Turn	180	101	56.2%	6.7	78.4	17.9	E
	Through	200	114	57.1%	6.9	62.7	9.7	E
	Right Turn	130	71	54.8%	5.9	32.0	8.3	C
	Subtotal	510	286	56.2%	11.2	60.6	12.3	E
Total		4240	3346	78.9%	14.5	84.0	25.1	F

Intersection

El Camino Real/Santa Cruz Ave

Signalized

Direction	Movement	Volume (veh/hr)			GEH	Total Delay (sec/veh)		
		Demand	Served	% Served		Average	Std. Dev.	LOS
NB	Left Turn							
	Through	1530	1283	83.9%	6.6	7.9	2.1	A
	Right Turn	80	71	89.1%	1.0	23.1	23.1	C
	Subtotal	1610	1355	84.1%	6.6	8.7	2.5	A
SB	Left Turn							
	Through	1220	961	78.8%	7.8	33.4	17.7	C
	Right Turn	100	83	82.7%	1.8	12.1	5.7	B
	Subtotal	1320	1044	79.1%	8.0	31.7	16.8	C
EB	Left Turn	180	87	48.6%	8.0	1941.0	422.4	F
	Through	280	144	51.4%	9.3	1975.0	459.5	F
	Right Turn	250	136	54.3%	8.2	1810.4	464.9	F
	Subtotal	710	367	51.7%	14.8	1901.4	435.8	F
WB	Left Turn	80	49	61.3%	3.9	66.6	16.4	E
	Through	280	177	63.3%	6.8	84.2	21.7	F
	Right Turn	60	39	65.0%	3.0	73.0	19.8	E
	Subtotal	420	265	63.1%	8.4	79.4	20.4	E
Total		4060	3031	74.7%	17.3	249.6	45.8	F

Intersection

Merril St/Santa Cruz Ave

Unsignalized

Direction	Movement	Volume (veh/hr)			GEH	Total Delay (sec/veh)		
		Demand	Served	% Served		Average	Std. Dev.	LOS
NB	Left Turn	220	147	66.9%	5.4	116.3	68.6	F
	Through	20	15	74.0%	1.2	123.6	74.8	F
	Right Turn	10	9	87.0%	0.4	124.5	76.2	F
	Subtotal	250	171	68.3%	5.5	116.8	68.8	F
SB	Left Turn	10	6	58.0%	1.5	399.2	434.8	F
	Through	270	125	46.2%	10.3	277.9	61.0	F
	Right Turn	150	67	44.5%	8.0	282.6	86.0	F
	Subtotal	430	197	45.9%	13.1	287.1	73.8	F
EB	Left Turn	250	155	62.0%	6.7	100.4	15.7	F
	Through	60	37	62.2%	3.3	102.5	19.1	F
	Right Turn	50	30	59.0%	3.3	110.3	23.9	F
	Subtotal	360	222	61.6%	8.1	102.2	16.3	F
WB	Left Turn	10	9	93.0%	0.2	110.6	44.4	F
	Through	50	51	102.0%	0.1	96.0	34.6	F
	Right Turn	40	46	113.8%	0.8	94.1	36.3	F
	Subtotal	100	106	105.8%	0.6	96.9	34.5	F
Total		1140	696	61.0%	14.7	155.6	29.7	F

SimTraffic Post-Processor
Average Results from 20 Runs
Volume and Delay by Movement

Caltrain Electrification
2040 Plus Project Conditions
PM Peak Hour

Intersection

Ravenswood Ave/Laurel St

Signalized

Direction	Movement	Volume (veh/hr)			GEH	Total Delay (sec/veh)		
		Demand	Served	% Served		Average	Std. Dev.	LOS
NB	Left Turn	200	189	94.3%	0.8	102.1	32.6	F
	Through	147	133	90.3%	1.2	68.9	24.4	E
	Right Turn	53	46	86.6%	1.0	66.2	24.3	E
	Subtotal	400	367	91.8%	1.7	85.4	27.9	F
SB	Left Turn	189	96	50.6%	7.8	380.5	19.3	F
	Through	137	69	50.2%	6.7	386.4	19.0	F
	Right Turn	200	108	54.2%	7.4	364.9	15.1	F
	Subtotal	526	273	51.8%	12.7	375.9	16.5	F
EB	Left Turn	147	93	63.5%	4.9	136.4	38.5	F
	Through	937	642	68.5%	10.5	27.4	3.0	C
	Right Turn	137	89	64.8%	4.5	24.5	4.7	C
	Subtotal	1221	824	67.5%	12.4	39.4	6.3	D
WB	Left Turn	42	37	87.1%	0.9	182.3	51.3	F
	Through	642	530	82.6%	4.6	157.1	46.0	F
	Right Turn	221	180	81.5%	2.9	154.6	46.1	F
	Subtotal	905	747	82.5%	5.5	157.7	46.3	F
Total		3052	2211	72.4%	16.4	127.8	18.8	F

SimTraffic Post-Processor
Average Results from 10 Runs
Volume and Delay by Movement

Caltrain Electrification
2040 Plus Project Conditions
PM Peak Hour

Intersection High Street/University Ave

Signalized

Direction	Movement	Volume (veh/hr)			GEH	Total Delay (sec/veh)		
		Demand	Served	% Served		Average	Std. Dev.	LOS
NB	Left Turn							
	Through							
	Right Turn							
	Subtotal							
SB	Left Turn	20	20	98.5%	0.1	57.3	16.7	E
	Through	70	71	101.7%	0.1	33.6	4.4	C
	Right Turn	290	294	101.4%	0.2	32.2	7.3	C
	Subtotal	380	385	101.3%	0.3	33.8	6.2	C
EB	Left Turn							
	Through	750	658	87.7%	3.5	24.7	5.7	C
	Right Turn	490	424	86.5%	3.1	12.7	3.9	B
	Subtotal	1240	1082	87.2%	4.6	20.0	4.9	B
WB	Left Turn	50	44	87.8%	0.9	40.8	13.2	D
	Through	700	689	98.5%	0.4	25.3	4.7	C
	Right Turn							
	Subtotal	750	733	97.7%	0.6	26.2	5.1	C
Total		2370	2200	92.8%	3.6	24.5	2.8	C

Intersection

Showers Drive/Pacchetti Way

Signalized

Direction	Movement	Volume (veh/hr)			GEH	Total Delay (sec/veh)		
		Demand	Served	% Served		Average	Std. Dev.	LOS
NB	Left Turn	10	8	82.0%	0.6	25.0	3.2	C
	Through	50	52	103.4%	0.2	3.8	1.3	A
	Right Turn							
	Subtotal	60	60	99.8%	0.0	6.7	1.6	A
SB	Left Turn							
	Through	250	251	100.4%	0.1	6.2	1.0	A
	Right Turn	60	58	97.2%	0.2	3.1	0.6	A
	Subtotal	310	309	99.8%	0.0	5.6	0.9	A
EB	Left Turn	30	29	97.3%	0.1	14.4	1.7	B
	Through							
	Right Turn	10	9	94.0%	0.2	3.8	1.5	A
	Subtotal	40	39	96.5%	0.2	11.9	1.3	B
WB	Left Turn							
	Through							
	Right Turn							
	Subtotal							
Total		410	408	99.5%	0.1	6.4	0.6	A

Intersection Hope Street/Evelyn Ave

Signalized

Direction	Movement	Volume (veh/hr)			GEH	Total Delay (sec/veh)		
		Demand	Served	% Served		Average	Std. Dev.	LOS
NB	Left Turn	60	58	96.7%	0.3	19.5	2.4	B
	Through							
	Right Turn	190	189	99.6%	0.1	5.7	0.3	A
	Subtotal	250	247	98.9%	0.2	8.9	0.8	A
SB	Left Turn							
	Through							
	Right Turn							
	Subtotal							
EB	Left Turn							
	Through	150	97	64.9%	4.7	2.0	0.3	A
	Right Turn	20	14	68.0%	1.6	0.6	0.3	A
	Subtotal	170	111	65.3%	5.0	1.8	0.3	A
WB	Left Turn	80	76	94.5%	0.5	2.8	0.8	A
	Through	210	207	98.3%	0.2	2.4	0.4	A
	Right Turn							
	Subtotal	290	282	97.3%	0.5	2.5	0.4	A
Total		710	640	90.2%	2.7	4.9	0.4	A

Intersection Castro Street/Villa Street

Signalized

Direction	Movement	Volume (veh/hr)			GEH	Total Delay (sec/veh)		
		Demand	Served	% Served		Average	Std. Dev.	LOS
NB	Left Turn	40	39	97.0%	0.2	147.9	39.1	F
	Through	250	234	93.5%	1.0	141.7	26.2	F
	Right Turn	100	98	98.4%	0.2	125.7	25.4	F
	Subtotal	390	371	95.1%	1.0	137.9	26.5	F
SB	Left Turn	290	180	61.9%	7.2	221.5	16.2	F
	Through	320	209	65.2%	6.8	60.5	2.5	E
	Right Turn	220	141	64.1%	5.9	50.9	1.6	D
	Subtotal	830	529	63.8%	11.5	112.9	7.6	F
EB	Left Turn	580	268	46.2%	15.1	226.5	15.9	F
	Through	260	118	45.3%	10.3	222.3	15.6	F
	Right Turn	40	18	45.0%	4.1	213.5	20.6	F
	Subtotal	880	404	45.9%	18.8	224.7	15.7	F
WB	Left Turn	130	133	102.0%	0.2	28.2	4.0	C
	Through	330	334	101.2%	0.2	27.0	2.4	C
	Right Turn	70	77	110.3%	0.8	22.6	2.8	C
	Subtotal	530	544	102.6%	0.6	26.7	2.7	C
Total		2630	1848	70.3%	16.5	116.8	5.6	F

SimTraffic Post-Processor
Average Results from 10 Runs
Volume and Delay by Movement

Caltrain Electrification
2040 Plus Project Conditions
PM Peak Hour

Intersection Frances St/Evelyn Ave

Signalized

Direction	Movement	Volume (veh/hr)			GEH	Total Delay (sec/veh)		
		Demand	Served	% Served		Average	Std. Dev.	LOS
NB	Left Turn	30	29	96.3%	0.2	42.1	8.9	D
	Through	60	61	101.3%	0.1	39.8	7.2	D
	Right Turn	20	23	116.0%	0.7	26.9	9.5	C
	Subtotal	110	113	102.6%	0.3	37.9	6.7	D
SB	Left Turn	310	192	62.0%	7.4	71.7	8.5	E
	Through	60	36	60.0%	3.5	69.6	4.7	E
	Right Turn	190	120	62.9%	5.7	58.5	6.3	E
	Subtotal	560	348	62.1%	10.0	67.0	6.3	E
EB	Left Turn	150	94	62.9%	5.0	452.7	49.8	F
	Through	880	579	65.8%	11.2	165.4	25.6	F
	Right Turn	70	44	62.4%	3.5	163.3	29.6	F
	Subtotal	1100	717	65.1%	12.7	203.6	32.0	F
WB	Left Turn	80	78	97.1%	0.3	109.2	19.8	F
	Through	390	441	113.0%	2.5	23.7	5.7	C
	Right Turn	300	295	98.4%	0.3	16.5	8.1	B
	Subtotal	770	813	105.6%	1.5	29.2	8.1	C
Total		2540	1991	78.4%	11.5	98.1	5.7	F

SimTraffic Post-Processor
Average Results from 20 Runs
Volume and Delay by Movement

Caltrain Electrification
2040 Plus Project Conditions
PM Peak Hour

Intersection Lawrence Expressway/Kifer Road

Signalized

Direction	Movement	Volume (veh/hr)			GEH	Total Delay (sec/veh)		
		Demand	Served	% Served		Average	Std. Dev.	LOS
NB	Left Turn	190	171	90.0%	1.4	203.6	49.8	F
	Through	2200	2132	96.9%	1.5	218.6	65.5	F
	Right Turn	300	293	97.7%	0.4	281.3	76.6	F
	Subtotal	2690	2596	96.5%	1.8	224.7	65.6	F
SB	Left Turn	810	275	34.0%	23.0	626.6	20.3	F
	Through	3920	1455	37.1%	47.6	72.1	26.8	E
	Right Turn	50	19	37.2%	5.4	51.8	41.6	D
	Subtotal	4780	1748	36.6%	53.1	159.5	17.8	F
EB	Left Turn	360	292	81.1%	3.8	156.2	126.4	F
	Through	780	615	78.8%	6.2	38.9	3.2	D
	Right Turn	1200	926	77.1%	8.4	198.6	6.6	F
	Subtotal	2340	1833	78.3%	11.1	138.2	17.9	F
WB	Left Turn	780	349	44.8%	18.1	1036.3	30.6	F
	Through	1060	526	49.6%	19.0	89.7	11.5	F
	Right Turn	260	140	53.8%	8.5	73.8	14.7	E
	Subtotal	2100	1015	48.3%	27.5	414.9	22.8	F
Total		11910	7192	60.4%	48.3	213.3	24.3	F

Intersection Lawrence Expressway/Reed Ave-Monroe St

Signalized

Direction	Movement	Volume (veh/hr)			GEH	Total Delay (sec/veh)		
		Demand	Served	% Served		Average	Std. Dev.	LOS
NB	Left Turn	190	160	84.0%	2.3	596.0	221.8	F
	Through	2250	2199	97.7%	1.1	57.8	15.6	E
	Right Turn	490	477	97.4%	0.6	42.6	15.7	D
	Subtotal	2930	2836	96.8%	1.7	85.4	18.5	F
SB	Left Turn	750	339	45.2%	17.6	61.4	5.6	E
	Through	4730	2200	46.5%	43.0	32.3	1.5	C
	Right Turn	420	200	47.6%	12.5	17.2	1.2	B
	Subtotal	5900	2739	46.4%	48.1	34.8	1.8	C
EB	Left Turn	340	283	83.3%	3.2	307.0	18.3	F
	Through	800	637	79.6%	6.1	405.7	22.0	F
	Right Turn	520	421	81.0%	4.6	268.1	18.9	F
	Subtotal	1660	1341	80.8%	8.2	341.7	19.8	F
WB	Left Turn	490	375	76.5%	5.5	427.1	19.6	F
	Through	430	338	78.5%	4.7	238.9	15.8	F
	Right Turn	100	72	72.3%	3.0	94.7	15.9	F
	Subtotal	1020	785	76.9%	7.8	315.7	11.4	F
Total		11510	7701	66.9%	38.9	135.4	6.0	F

SimTraffic Post-Processor
Average Results from 10 Runs
Volume and Delay by Movement

Caltrain Electrification
2040 Plus Project Conditions
PM Peak Hour

Intersection El Camino Real/Railroad Ave

Signalized

Direction	Movement	Volume (veh/hr)			GEH	Total Delay (sec/veh)		
		Demand	Served	% Served		Average	Std. Dev.	LOS
NB	Left Turn	290	287	99.0%	0.2	69.6	16.2	E
	Through	1140	1152	101.1%	0.4	14.3	0.9	B
	Right Turn	30	27	91.0%	0.5	14.1	2.5	B
	Subtotal	1460	1467	100.5%	0.2	25.2	3.8	C
SB	Left Turn	120	119	99.5%	0.1	51.8	3.8	D
	Through	1930	1890	97.9%	0.9	49.7	3.2	D
	Right Turn	270	260	96.2%	0.6	63.4	3.5	E
	Subtotal	2320	2269	97.8%	1.1	51.4	3.1	D
EB	Left Turn	90	95	106.0%	0.6	34.9	2.9	C
	Through	10	11	105.0%	0.2	26.5	8.6	C
	Right Turn	200	201	100.6%	0.1	14.5	1.0	B
	Subtotal	300	307	102.3%	0.4	21.3	1.2	C
WB	Left Turn	120	118	98.6%	0.2	37.6	1.9	D
	Through	10	11	109.0%	0.3	23.6	10.3	C
	Right Turn	40	42	106.0%	0.4	7.9	1.4	A
	Subtotal	170	172	100.9%	0.1	29.5	1.6	C
Total		4250	4214	99.2%	0.6	39.2	2.0	D

SimTraffic Post-Processor
Average Results from 10 Runs
Volume and Delay by Movement

Caltrain Electrification
2040 Plus Project Conditions
PM Peak Hour

Intersection Santa Clara Street/Cahill Street

Signalized

Direction	Movement	Volume (veh/hr)			GEH	Total Delay (sec/veh)		
		Demand	Served	% Served		Average	Std. Dev.	LOS
NB	Left Turn	170	96	56.5%	6.4	45.7	5.1	D
	Through	10	11	105.0%	0.2	24.9	9.1	C
	Right Turn	370	206	55.8%	9.6	45.7	7.9	D
	Subtotal	550	313	56.9%	11.4	45.1	6.6	D
SB	Left Turn	10	13	128.0%	0.8	57.6	8.0	E
	Through	10	9	94.0%	0.2	53.4	11.5	D
	Right Turn	20	18	88.5%	0.5	12.5	4.5	B
	Subtotal	40	40	99.8%	0.0	35.8	4.5	D
EB	Left Turn	10	0	0.0%	4.5	0.0	0.0	A
	Through	1380	1139	82.6%	6.8	77.0	7.1	E
	Right Turn	190	155	81.6%	2.7	73.3	6.5	E
	Subtotal	1580	1295	81.9%	7.5	76.6	6.4	E
WB	Left Turn	190	90	47.3%	8.5	44.8	3.5	D
	Through	920	472	51.3%	17.0	5.4	1.3	A
	Right Turn	10	5	49.0%	1.9	4.8	5.1	A
	Subtotal	1120	567	50.6%	19.1	11.7	1.1	B
Total		3290	2214	67.3%	20.5	54.7	3.7	D

Intersection San Fernando Street/Montgomery Street

Signalized

Direction	Movement	Volume (veh/hr)			GEH	Total Delay (sec/veh)		
		Demand	Served	% Served		Average	Std. Dev.	LOS
NB	Left Turn							
	Through							
	Right Turn							
	Subtotal							
SB	Left Turn	150	76	50.9%	6.9	76.1	12.3	E
	Through	2080	1077	51.8%	25.2	84.5	19.4	F
	Right Turn	50	24	47.6%	4.3	83.4	25.2	F
	Subtotal	2280	1177	51.6%	26.5	83.9	18.8	F
EB	Left Turn							
	Through	280	243	86.9%	2.3	29.6	2.1	C
	Right Turn	270	227	84.0%	2.7	28.8	4.5	C
	Subtotal	550	470	85.5%	3.5	29.2	3.1	C
WB	Left Turn	270	109	40.4%	11.7	189.8	69.0	F
	Through	420	181	43.2%	13.8	193.3	70.1	F
	Right Turn							
	Subtotal	690	290	42.1%	18.0	192.1	67.9	F
Total		3520	1938	55.1%	30.3	86.3	15.8	F

Intersection Lick Avenue-Shadow Run Drive/Alma Avenue

Signalized

Direction	Movement	Volume (veh/hr)			GEH	Total Delay (sec/veh)		
		Demand	Served	% Served		Average	Std. Dev.	LOS
NB	Left Turn	50	49	98.4%	0.1	68.5	6.7	E
	Through	20	22	108.5%	0.4	59.6	12.7	E
	Right Turn	10	12	123.0%	0.7	24.2	4.5	C
	Subtotal	80	83	104.0%	0.4	59.6	5.5	E
SB	Left Turn	540	383	70.9%	7.3	113.2	7.1	F
	Through	80	58	72.1%	2.7	80.3	8.8	F
	Right Turn	330	237	71.7%	5.5	62.5	5.3	E
	Subtotal	950	677	71.3%	9.6	92.7	5.7	F
EB	Left Turn	100	100	99.5%	0.1	100.8	9.9	F
	Through	980	1001	102.2%	0.7	46.0	7.2	D
	Right Turn	40	38	95.5%	0.3	48.7	9.0	D
	Subtotal	1120	1139	101.7%	0.6	50.8	7.2	D
WB	Left Turn	20	18	90.5%	0.4	122.4	15.8	F
	Through	940	938	99.8%	0.1	56.1	6.7	E
	Right Turn	110	113	102.6%	0.3	60.5	6.7	E
	Subtotal	1070	1069	99.9%	0.0	57.7	6.7	E
Total		3220	2969	92.2%	4.5	63.0	4.0	E

SimTraffic Post-Processor
Average Results from 10 Runs
Volume and Delay by Movement

Caltrain Electrification
2040 Plus Project Conditions
PM Peak Hour

Intersection 7th Street/Mission Bay

Signalized

Direction	Movement	Volume (veh/hr)			GEH	Total Delay (sec/veh)		
		Demand	Served	% Served		Average	Std. Dev.	LOS
NB	Left Turn	10	8	83.0%	0.6	25.3	13.1	C
	Through	1380	1394	101.0%	0.4	15.6	1.1	B
	Right Turn	80	78	97.8%	0.2	21.3	3.1	C
	Subtotal	1470	1481	100.7%	0.3	16.0	1.0	B
SB	Left Turn	130	125	95.8%	0.5	76.4	3.9	E
	Through	350	342	97.6%	0.4	5.9	0.6	A
	Right Turn	10	12	122.0%	0.7	3.7	1.8	A
	Subtotal	490	479	97.7%	0.5	24.2	2.1	C
EB	Left Turn							
	Through							
	Right Turn							
	Subtotal							
WB	Left Turn	40	39	97.0%	0.2	2.9	2.0	A
	Through							
	Right Turn	90	88	98.2%	0.2	0.6	0.0	A
	Subtotal	130	127	97.8%	0.2	1.3	0.5	A
Total		2090	2086	99.8%	0.1	17.0	0.7	B

Intersection Berry Street/Mission Bay

Signalized

Direction	Movement	Volume (veh/hr)			GEH	Total Delay (sec/veh)		
		Demand	Served	% Served		Average	Std. Dev.	LOS
NB	Left Turn							
	Through							
	Right Turn							
	Subtotal							
SB	Left Turn							
	Through							
	Right Turn	130	128	98.5%	0.2	21.1	3.5	C
	Subtotal	130	128	98.5%	0.2	21.1	3.5	C
EB	Left Turn	210	203	96.4%	0.5	0.5	0.2	A
	Through							
	Right Turn							
	Subtotal	210	203	96.4%	0.5	0.5	0.2	A
WB	Left Turn							
	Through							
	Right Turn							
	Subtotal							
Total		340	331	97.2%	0.5	8.6	1.9	A

Intersection Main Street/Maple Street

Unsignalized

Direction	Movement	Volume (veh/hr)			GEH	Total Delay (sec/veh)		
		Demand	Served	% Served		Average	Std. Dev.	LOS
NB	Left Turn							
	Through	480	328	68.2%	7.6	50.5	3.6	F
	Right Turn							
	Subtotal	480	328	68.2%	7.6	50.5	3.6	F
SB	Left Turn							
	Through	580	290	50.0%	13.9	13.2	2.9	B
	Right Turn							
	Subtotal	580	290	50.0%	13.9	13.2	2.9	B
EB	Left Turn							
	Through							
	Right Turn							
	Subtotal							
WB	Left Turn							
	Through							
	Right Turn	20	16	79.5%	1.0	674.6	379.4	F
	Subtotal	20	16	79.5%	1.0	674.6	379.4	F
Total		1080	634	58.7%	15.3	48.2	7.3	E

Intersection Main Street/Beech Street

Unsignalized

Direction	Movement	Volume (veh/hr)			GEH	Total Delay (sec/veh)		
		Demand	Served	% Served		Average	Std. Dev.	LOS
NB	Left Turn	100	66	65.9%	3.7	230.4	29.2	F
	Through	290	192	66.2%	6.3	236.9	33.9	F
	Right Turn							
	Subtotal	390	258	66.1%	7.3	235.2	32.2	F
SB	Left Turn							
	Through	400	206	51.5%	11.1	0.9	0.6	A
	Right Turn	10	6	58.0%	1.5	0.6	0.5	A
	Subtotal	410	212	51.7%	11.2	0.9	0.5	A
EB	Left Turn	90	42	46.3%	6.0	1180.0	192.6	F
	Through							
	Right Turn	30	13	43.3%	3.7	1069.8	394.6	F
	Subtotal	120	55	45.6%	7.0	1141.9	213.5	F
WB	Left Turn							
	Through							
	Right Turn							
	Subtotal							
Total		920	524	57.0%	14.7	234.1	29.9	F

SimTraffic Post-Processor
Average Results from 20 Runs
Volume and Delay by Movement

Caltrain Electrification
2040 Plus Project Conditions
PM Peak Hour

Intersection Main Street/Middlefield Road

Signalized

Direction	Movement	Volume (veh/hr)			GEH	Total Delay (sec/veh)		
		Demand	Served	% Served		Average	Std. Dev.	LOS
NB	Left Turn	60	40	66.5%	2.8	272.2	64.6	F
	Through	400	271	67.7%	7.1	103.0	2.6	F
	Right Turn	40	28	69.8%	2.1	112.5	40.8	F
	Subtotal	500	339	67.7%	7.9	124.5	10.5	F
SB	Left Turn	150	47	31.1%	10.4	2153.5	352.0	F
	Through	390	178	45.7%	12.6	234.9	48.1	F
	Right Turn	60	23	37.8%	5.8	12.0	7.2	B
	Subtotal	600	248	41.3%	17.1	573.0	54.7	F
EB	Left Turn	90	55	61.0%	4.1	230.5	9.9	F
	Through	990	572	57.8%	14.9	244.2	4.5	F
	Right Turn	130	75	57.8%	5.4	249.4	10.5	F
	Subtotal	1210	702	58.0%	16.4	243.7	5.1	F
WB	Left Turn	60	28	47.3%	4.8	17.6	6.0	B
	Through	880	413	46.9%	18.4	11.6	0.9	B
	Right Turn	100	49	48.6%	6.0	0.4	0.1	A
	Subtotal	1040	490	47.1%	19.9	10.8	0.6	B
Total		3350	1779	53.1%	31.0	201.9	7.4	F

SimTraffic Post-Processor
Average Results from 20 Runs
Volume and Delay by Movement

Caltrain Electrification
2040 Plus Project Conditions
PM Peak Hour

Intersection Fair Oaks Lane/Middlefield Road

Unsignalized

Direction	Movement	Volume (veh/hr)			GEH	Total Delay (sec/veh)		
		Demand	Served	% Served		Average	Std. Dev.	LOS
NB	Left Turn	30	19	63.7%	2.2	1057.5	396.3	F
	Through	20	12	59.0%	2.1	1041.5	455.6	F
	Right Turn	130	90	69.3%	3.8	854.9	364.8	F
	Subtotal	180	121	67.2%	4.8	905.4	375.5	F
SB	Left Turn	10	8	76.0%	0.8	667.1	398.6	F
	Through	20	21	104.5%	0.2	606.9	301.6	F
	Right Turn	10	11	106.0%	0.2	568.3	325.7	F
	Subtotal	40	39	97.8%	0.1	607.3	317.4	F
EB	Left Turn	20	20	98.0%	0.1	11.6	2.4	B
	Through	710	712	100.3%	0.1	5.8	1.0	A
	Right Turn	120	115	95.4%	0.5	4.9	1.2	A
	Subtotal	850	846	99.6%	0.1	5.8	1.0	A
WB	Left Turn	190	166	87.1%	1.8	26.2	5.2	D
	Through	1090	959	88.0%	4.1	8.6	2.4	A
	Right Turn	20	20	99.0%	0.0	7.1	3.0	A
	Subtotal	1300	1144	88.0%	4.5	11.1	2.8	B
Total		2370	2151	90.7%	4.6	69.0	20.5	F

Intersection Watkins Avenue/Middlefield Road

Unsignalized

Direction	Movement	Volume (veh/hr)			GEH	Total Delay (sec/veh)		
		Demand	Served	% Served		Average	Std. Dev.	LOS
NB	Left Turn	80	52	65.5%	3.4	1069.7	306.6	F
	Through							
	Right Turn	160	99	61.8%	5.4	917.2	323.9	F
	Subtotal	240	151	63.0%	6.3	969.5	316.1	F
SB	Left Turn							
	Through							
	Right Turn							
	Subtotal							
EB	Left Turn							
	Through	690	659	95.5%	1.2	5.7	0.4	A
	Right Turn	160	153	95.5%	0.6	4.5	0.3	A
	Subtotal	850	812	95.5%	1.3	5.4	0.3	A
WB	Left Turn	160	136	85.0%	2.0	22.4	2.1	C
	Through	1220	1109	90.9%	3.3	9.5	0.9	A
	Right Turn							
	Subtotal	1380	1245	90.2%	3.7	10.9	0.9	B
Total		2470	2208	89.4%	5.4	72.0	15.5	F

SimTraffic Post-Processor
Average Results from 20 Runs
Volume and Delay by Movement

Caltrain Electrification
2040 Plus Project Conditions
PM Peak Hour

Intersection

Linden Avenue-Glenwood Avenue/Middlefield Road

Unsignalized

Direction	Movement	Volume (veh/hr)			GEH	Total Delay (sec/veh)		
		Demand	Served	% Served		Average	Std. Dev.	LOS
NB	Left Turn	130	20	15.2%	12.7	3743.8	903.6	F
	Through	50	6	12.6%	8.2	3823.3	960.0	F
	Right Turn	240	35	14.5%	17.5	3497.0	863.7	F
	Subtotal	420	61	14.5%	23.2	3618.5	842.5	F
SB	Left Turn	20	7	33.0%	3.7	3084.6	1079.6	F
	Through	40	11	27.8%	5.7	2952.9	741.3	F
	Right Turn	60	17	28.2%	7.0	2880.7	924.0	F
	Subtotal	120	35	28.8%	9.7	2944.7	872.4	F
EB	Left Turn	50	46	92.4%	0.5	81.5	43.9	F
	Through	670	606	90.5%	2.5	10.8	6.7	B
	Right Turn	130	118	90.6%	1.1	10.1	7.6	B
	Subtotal	850	770	90.6%	2.8	15.2	9.4	C
WB	Left Turn	120	109	91.0%	1.0	17.4	3.9	C
	Through	1190	1184	99.5%	0.2	9.5	1.6	A
	Right Turn	90	91	100.9%	0.1	7.9	1.8	A
	Subtotal	1400	1384	98.9%	0.4	10.0	1.7	A
Total		2790	2250	80.6%	10.8	148.0	14.9	F

SimTraffic Post-Processor
Average Results from 20 Runs
Volume and Delay by Movement

Caltrain Electrification
2040 Plus Project Conditions
PM Peak Hour

Intersection California Street/Rengstorff Avenue

Signalized

Direction	Movement	Volume (veh/hr)			GEH	Total Delay (sec/veh)		
		Demand	Served	% Served		Average	Std. Dev.	LOS
NB	Left Turn	170	135	79.2%	2.9	626.5	163.5	F
	Through	460	418	90.8%	2.0	273.1	70.7	F
	Right Turn	230	204	88.7%	1.8	248.3	69.2	F
	Subtotal	860	756	87.9%	3.7	329.8	82.2	F
SB	Left Turn	330	201	60.8%	7.9	376.3	16.3	F
	Through	870	537	61.8%	12.5	298.3	9.1	F
	Right Turn	560	353	63.1%	9.7	294.0	7.9	F
	Subtotal	1760	1092	62.0%	17.7	311.3	8.1	F
EB	Left Turn	100	82	81.6%	1.9	204.6	12.9	F
	Through	640	531	83.0%	4.5	176.9	10.2	F
	Right Turn	430	370	86.1%	3.0	197.4	11.4	F
	Subtotal	1170	983	84.0%	5.7	186.9	10.5	F
WB	Left Turn	710	312	43.9%	17.6	377.6	4.6	F
	Through	450	206	45.7%	13.5	81.5	2.3	F
	Right Turn	290	128	44.1%	11.2	69.2	4.8	E
	Subtotal	1450	645	44.5%	24.9	222.2	4.4	F
Total		5240	3476	66.3%	26.7	263.2	17.7	F

2040 Project Mitigated



Intersection

Tunnel Avenue/Blanken Avenue

Signalized

Direction	Movement	Volume (veh/hr)			GEH	Total Delay (sec/veh)		
		Demand	Served	% Served		Average	Std. Dev.	LOS
NB	Left Turn	50	45	89.4%	0.8	20.8	1.9	C
	Through	220	227	103.2%	0.5	17.0	1.8	B
	Right Turn	20	18	92.0%	0.4	14.1	2.4	B
	Subtotal	290	290	100.1%	0.0	17.4	1.8	B
SB	Left Turn	100	97	96.5%	0.4	28.0	4.7	C
	Through	180	174	96.4%	0.5	24.0	4.2	C
	Right Turn	10	11	112.0%	0.4	20.4	8.0	C
	Subtotal	290	281	97.0%	0.5	25.2	4.3	C
EB	Left Turn	20	17	87.0%	0.6	17.9	4.0	B
	Through	300	298	99.2%	0.1	13.8	1.1	B
	Right Turn	200	203	101.3%	0.2	10.2	1.3	B
	Subtotal	520	518	99.5%	0.1	12.5	1.1	B
WB	Left Turn	20	16	79.5%	1.0	25.1	6.3	C
	Through	270	272	100.6%	0.1	12.7	2.1	B
	Right Turn	120	119	99.5%	0.1	8.8	2.0	A
	Subtotal	410	407	99.3%	0.1	12.0	2.0	B
Total		1510	1496	99.1%	0.4	15.7	1.1	B

Intersection

Linden Avenue-San Mateo Avenue/San Mateo Avenue

Signalized

Direction	Movement	Volume (veh/hr)			GEH	Total Delay (sec/veh)		
		Demand	Served	% Served		Average	Std. Dev.	LOS
NB	Left Turn							
	Through	360	349	97.0%	0.6	59.8	26.8	E
	Right Turn	340	344	101.0%	0.2	35.6	22.5	D
	Subtotal	700	693	99.0%	0.3	47.8	24.7	D
SB	Left Turn	170	139	81.8%	2.5	28.4	6.0	C
	Through	300	242	80.6%	3.5	5.0	0.6	A
	Right Turn							
	Subtotal	470	381	81.1%	4.3	13.6	3.1	B
EB	Left Turn							
	Through							
	Right Turn							
	Subtotal							
WB	Left Turn	370	357	96.4%	0.7	29.7	12.9	C
	Through							
	Right Turn	100	96	96.4%	0.4	9.7	7.9	A
	Subtotal	470	453	96.4%	0.8	25.5	12.0	C
Total		1640	1527	93.1%	2.8	32.7	13.4	C

Intersection

Herman Street/Scott Street

Unsignalized

Direction	Movement	Volume (veh/hr)			GEH	Total Delay (sec/veh)		
		Demand	Served	% Served		Average	Std. Dev.	LOS
NB	Left Turn	10	11	109.0%	0.3	43.9	24.8	E
	Through	230	229	99.3%	0.1	48.4	23.6	E
	Right Turn	270	270	100.0%	0.0	45.3	23.7	E
	Subtotal	510	509	99.9%	0.0	46.6	23.6	E
SB	Left Turn	70	72	102.3%	0.2	17.5	4.0	C
	Through	190	186	97.6%	0.3	15.3	2.5	C
	Right Turn	10	11	110.0%	0.3	13.0	8.1	B
	Subtotal	270	268	99.3%	0.1	15.8	2.9	C
EB	Left Turn	10	8	84.0%	0.5	7.9	1.8	A
	Through	50	49	98.2%	0.1	12.3	2.8	B
	Right Turn	10	11	106.0%	0.2	5.3	1.3	A
	Subtotal	70	68	97.3%	0.2	10.8	2.3	B
WB	Left Turn	100	94	94.1%	0.6	0.4	0.0	A
	Through	20	23	115.0%	0.6	0.6	0.3	A
	Right Turn	100	103	102.8%	0.3	0.2	0.1	A
	Subtotal	220	220	100.0%	0.0	0.3	0.0	A
Total		1070	1065	99.6%	0.1	26.9	11.6	D

Intersection **Montgomery Avenue/Scott Street**

Unsignalized

Direction	Movement	Volume (veh/hr)			GEH	Total Delay (sec/veh)		
		Demand	Served	% Served		Average	Std. Dev.	LOS
NB	Left Turn	30	30	99.3%	0.0	9.9	1.8	A
	Through	10	13	125.0%	0.7	8.9	1.7	A
	Right Turn	20	23	114.5%	0.6	4.9	0.8	A
	Subtotal	60	65	108.7%	0.7	7.9	0.8	A
SB	Left Turn	10	9	93.0%	0.2	7.8	2.0	A
	Through	10	9	87.0%	0.4	9.9	1.8	A
	Right Turn	20	20	99.0%	0.0	4.2	1.0	A
	Subtotal	40	38	94.5%	0.4	6.4	1.2	A
EB	Left Turn	60	54	89.5%	0.8	2.5	0.2	A
	Through	290	299	103.0%	0.5	0.9	0.1	A
	Right Turn	40	40	98.8%	0.1	0.5	0.2	A
	Subtotal	390	392	100.5%	0.1	1.1	0.1	A
WB	Left Turn	20	20	100.5%	0.0	3.3	0.7	A
	Through	170	170	100.0%	0.0	0.6	0.2	A
	Right Turn	10	11	106.0%	0.2	0.1	0.1	A
	Subtotal	200	201	100.4%	0.0	0.8	0.2	A
Total		690	696	100.8%	0.2	1.9	0.2	A

Intersection **Driveway-Dollar Avenue/Linden Avenue**

Signalized

Direction	Movement	Volume (veh/hr)			GEH	Total Delay (sec/veh)		
		Demand	Served	% Served		Average	Std. Dev.	LOS
NB	Left Turn	130	129	99.4%	0.1	41.9	6.9	D
	Through							
	Right Turn	120	121	100.7%	0.1	42.5	9.3	D
	Subtotal	250	250	100.0%	0.0	42.2	7.7	D
SB	Left Turn	10	10	103.0%	0.1	61.1	12.7	E
	Through							
	Right Turn							
	Subtotal	10	10	103.0%	0.1	61.1	12.7	E
EB	Left Turn							
	Through	340	249	73.1%	5.3	190.6	16.6	F
	Right Turn	140	99	70.5%	3.8	183.0	14.9	F
	Subtotal	480	347	72.3%	6.5	188.4	15.5	F
WB	Left Turn	110	109	98.9%	0.1	6.3	2.0	A
	Through	340	328	96.6%	0.6	7.3	0.7	A
	Right Turn	10	8	84.0%	0.5	0.4	0.2	A
	Subtotal	460	446	96.8%	0.7	6.9	0.6	A
Total		1200	1053	87.8%	4.4	75.5	4.3	E

Intersection

San Mateo Avenue/San Bruno Avenue

Signalized

Direction	Movement	Volume (veh/hr)			GEH	Total Delay (sec/veh)		
		Demand	Served	% Served		Average	Std. Dev.	LOS
NB	Left Turn	70	57	82.0%	1.6	177.6	22.2	F
	Through	200	168	84.2%	2.3	157.4	12.7	F
	Right Turn	160	126	78.9%	2.8	138.7	11.6	F
	Subtotal	430	352	81.9%	3.9	154.1	12.1	F
SB	Left Turn	110	109	98.7%	0.1	67.9	22.0	E
	Through	150	145	96.6%	0.4	64.0	28.8	E
	Right Turn	130	129	99.0%	0.1	56.1	22.6	E
	Subtotal	390	382	98.0%	0.4	62.7	24.2	E
EB	Left Turn	320	217	67.8%	6.3	45.9	1.6	D
	Through	370	274	74.0%	5.4	3.5	0.3	A
	Right Turn	10	8	81.0%	0.6	1.7	0.9	A
	Subtotal	700	499	71.2%	8.2	21.9	0.8	C
WB	Left Turn	320	317	99.0%	0.2	28.2	7.5	C
	Through	570	570	100.0%	0.0	32.5	6.2	C
	Right Turn	140	139	98.9%	0.1	31.0	6.9	C
	Subtotal	1030	1025	99.5%	0.1	31.0	6.0	C
Total		2550	2258	88.6%	6.0	53.6	6.1	D

Intersection El Camino Real/Millbrae Avenue

Signalized

Direction	Movement	Volume (veh/hr)			GEH	Total Delay (sec/veh)		
		Demand	Served	% Served		Average	Std. Dev.	LOS
NB	Left Turn	90	88	97.8%	0.2	78.8	9.0	E
	Through	1330	1325	99.6%	0.1	93.7	18.4	F
	Right Turn	550	548	99.6%	0.1	4.7	1.0	A
	Subtotal	1970	1961	99.5%	0.2	68.1	12.7	E
SB	Left Turn	800	536	67.0%	10.2	267.1	6.3	F
	Through	1120	754	67.3%	12.0	65.2	2.4	E
	Right Turn	40	29	73.0%	1.8	62.8	4.8	E
	Subtotal	1960	1319	67.3%	15.8	147.3	4.3	F
EB	Left Turn	70	66	93.9%	0.5	177.9	51.2	F
	Through	700	689	98.5%	0.4	115.7	54.7	F
	Right Turn	170	174	102.1%	0.3	127.5	60.8	F
	Subtotal	940	929	98.8%	0.4	122.2	55.3	F
WB	Left Turn	640	543	84.8%	4.0	235.0	64.5	F
	Through	240	223	93.0%	1.1	32.7	1.6	C
	Right Turn	530	485	91.4%	2.0	19.1	1.6	B
	Subtotal	1410	1250	88.7%	4.4	114.6	26.5	F
Total		6280	5459	86.9%	10.7	107.0	10.7	F

Intersection Rollins Road/Millbrae Avenue

Signalized

Direction	Movement	Volume (veh/hr)			GEH	Total Delay (sec/veh)		
		Demand	Served	% Served		Average	Std. Dev.	LOS
NB	Left Turn	160	97	60.6%	5.6	119.4	39.0	F
	Through	320	203	63.6%	7.2	272.8	20.6	F
	Right Turn	360	229	63.5%	7.7	195.7	16.2	F
	Subtotal	840	529	63.0%	11.9	211.0	17.0	F
SB	Left Turn	220	223	101.3%	0.2	56.5	2.5	E
	Through	90	91	100.8%	0.1	57.3	3.0	E
	Right Turn	210	211	100.4%	0.1	43.2	33.9	D
	Subtotal	520	524	100.8%	0.2	51.4	13.6	D
EB	Left Turn	330	287	86.9%	2.5	83.9	6.0	F
	Through	1410	1227	87.0%	5.1	42.0	2.3	D
	Right Turn	310	269	86.7%	2.4	26.2	2.0	C
	Subtotal	2050	1782	86.9%	6.1	46.3	2.4	D
WB	Left Turn	720	660	91.7%	2.3	159.9	9.2	F
	Through	1040	951	91.4%	2.8	55.6	4.4	E
	Right Turn	520	471	90.6%	2.2	8.5	1.1	A
	Subtotal	2280	2082	91.3%	4.2	78.1	4.6	E
Total		5690	4918	86.4%	10.6	77.9	3.2	E

Intersection

California Drive/Oak Grove Avenue

Signalized

Direction	Movement	Volume (veh/hr)			GEH	Total Delay (sec/veh)		
		Demand	Served	% Served		Average	Std. Dev.	LOS
NB	Left Turn	60	29	48.2%	4.7	290.7	86.6	F
	Through	540	291	53.9%	12.2	268.2	74.5	F
	Right Turn	260	119	45.7%	10.3	752.8	142.0	F
	Subtotal	860	439	51.0%	16.5	403.6	50.3	F
SB	Left Turn	140	20	13.9%	13.5	3905.3	420.7	F
	Through	820	143	17.5%	30.8	139.8	20.9	F
	Right Turn	60	9	15.3%	8.6	33.4	26.2	C
	Subtotal	1020	172	16.9%	34.7	592.9	122.2	F
EB	Left Turn	110	92	83.6%	1.8	294.6	41.0	F
	Through	420	348	82.8%	3.7	303.4	40.0	F
	Right Turn	40	34	84.0%	1.1	290.0	41.8	F
	Subtotal	570	473	83.0%	4.2	300.7	40.0	F
WB	Left Turn	160	76	47.4%	7.8	49.2	4.0	D
	Through	130	62	47.5%	7.0	47.4	3.6	D
	Right Turn	300	140	46.5%	10.8	21.3	2.9	C
	Subtotal	590	277	47.0%	15.0	34.7	1.6	C
Total		3040	1361	44.8%	35.8	311.6	17.1	F

Intersection

Carolan Avenue/Oak Grove Avenue

Signalized

Direction	Movement	Volume (veh/hr)			GEH	Total Delay (sec/veh)		
		Demand	Served	% Served		Average	Std. Dev.	LOS
NB	Left Turn	150	9	5.9%	15.8	5993.6	3662.2	F
	Through	120	8	6.3%	14.1	6090.0	3574.9	F
	Right Turn	40	2	4.5%	8.4	4857.7	4326.4	F
	Subtotal	310	18	5.9%	22.8	5954.9	3237.9	F
SB	Left Turn	10	10	100.0%	0.0	117.9	22.7	F
	Through	450	437	97.1%	0.6	117.1	9.4	F
	Right Turn	170	156	91.6%	1.1	184.5	34.8	F
	Subtotal	630	603	95.7%	1.1	134.6	12.1	F
EB	Left Turn	460	277	60.2%	9.5	7.4	0.7	A
	Through	270	174	64.5%	6.4	7.9	1.2	A
	Right Turn	90	49	54.1%	5.0	3.6	1.9	A
	Subtotal	820	500	61.0%	12.5	7.2	0.3	A
WB	Left Turn	20	9	45.0%	2.9	480.5	68.0	F
	Through	270	103	38.1%	12.2	543.8	54.7	F
	Right Turn	130	49	37.5%	8.6	506.4	70.5	F
	Subtotal	420	161	38.3%	15.2	529.3	57.6	F
Total		2180	1282	58.8%	21.6	208.2	25.0	F

Intersection California Drive/North Lane

Unsignalized

Direction	Movement	Volume (veh/hr)			GEH	Total Delay (sec/veh)		
		Demand	Served	% Served		Average	Std. Dev.	LOS
NB	Left Turn							
	Through	930	910	97.8%	0.7	1.9	0.2	A
	Right Turn	310	310	100.0%	0.0	3.4	0.5	A
	Subtotal	1240	1220	98.4%	0.6	2.3	0.2	A
SB	Left Turn	210	206	98.1%	0.3	56.4	20.6	F
	Through	210	213	101.6%	0.2	0.8	0.1	A
	Right Turn							
	Subtotal	420	419	99.8%	0.0	28.2	10.4	D
EB	Left Turn							
	Through							
	Right Turn							
	Subtotal							
WB	Left Turn	80	50	63.0%	3.7	80.3	19.5	F
	Through							
	Right Turn	210	149	71.1%	4.5	6.3	0.8	A
	Subtotal	290	200	68.9%	5.8	25.1	4.7	D
Total		1950	1839	94.3%	2.6	10.6	2.6	B

Intersection Carolan Avenue/North Lane

Unsignalized

Direction	Movement	Volume (veh/hr)			GEH	Total Delay (sec/veh)		
		Demand	Served	% Served		Average	Std. Dev.	LOS
NB	Left Turn	140	85	60.6%	5.2	380.7	73.0	F
	Through	240	144	60.0%	6.9	175.8	21.6	F
	Right Turn	20	12	60.5%	2.0	178.0	44.4	F
	Subtotal	400	241	60.3%	8.9	248.8	39.0	F
SB	Left Turn	10	9	90.0%	0.3	423.6	119.8	F
	Through	210	151	72.0%	4.4	438.6	94.0	F
	Right Turn	150	112	74.4%	3.4	428.1	88.3	F
	Subtotal	370	272	73.5%	5.5	434.3	90.6	F
EB	Left Turn	340	340	100.0%	0.0	1.6	0.2	A
	Through	20	25	127.0%	1.1	1.3	0.5	A
	Right Turn	160	156	97.5%	0.3	0.9	0.2	A
	Subtotal	520	522	100.3%	0.1	1.4	0.1	A
WB	Left Turn							
	Through							
	Right Turn							
	Subtotal							
Total		1290	1035	80.2%	7.5	170.4	21.9	F

Intersection **Railroad Avenue/9th Avenue**

Unsignalized

Direction	Movement	Volume (veh/hr)			GEH	Total Delay (sec/veh)		
		Demand	Served	% Served		Average	Std. Dev.	LOS
NB	Left Turn	40	40	100.5%	0.0	323.5	94.9	F
	Through							
	Right Turn	20	20	98.0%	0.1	278.5	87.8	F
	Subtotal	60	60	99.7%	0.0	309.4	86.9	F
SB	Left Turn							
	Through							
	Right Turn							
	Subtotal							
EB	Left Turn							
	Through	610	619	101.4%	0.3	3.5	0.3	A
	Right Turn	130	124	95.5%	0.5	1.4	0.2	A
	Subtotal	740	743	100.4%	0.1	3.1	0.3	A
WB	Left Turn	10	11	106.0%	0.2	14.0	3.6	B
	Through	690	695	100.7%	0.2	10.7	3.2	B
	Right Turn							
	Subtotal	700	706	100.8%	0.2	10.7	3.2	B
Total		1500	1508	100.5%	0.2	18.7	4.5	C

Intersection **S B Street/9th Avenue**

Signalized

Direction	Movement	Volume (veh/hr)			GEH	Total Delay (sec/veh)		
		Demand	Served	% Served		Average	Std. Dev.	LOS
NB	Left Turn	10	12	120.0%	0.6	55.8	19.8	E
	Through	110	108	97.7%	0.2	41.7	5.9	D
	Right Turn	160	162	101.3%	0.2	32.3	4.9	C
	Subtotal	280	282	100.5%	0.1	36.8	4.9	D
SB	Left Turn	80	77	96.5%	0.3	143.7	49.1	F
	Through	120	135	112.8%	1.4	67.9	20.7	E
	Right Turn	150	151	100.7%	0.1	64.4	32.1	E
	Subtotal	350	364	103.9%	0.7	82.9	30.9	F
EB	Left Turn	40	39	97.5%	0.2	70.5	19.8	E
	Through	500	494	98.8%	0.3	59.1	18.6	E
	Right Turn	10	11	106.0%	0.2	56.4	26.6	E
	Subtotal	550	544	98.9%	0.3	59.8	18.8	E
WB	Left Turn	140	138	98.6%	0.2	27.9	5.0	C
	Through	490	487	99.4%	0.1	11.7	1.2	B
	Right Turn	100	104	104.1%	0.4	7.7	1.2	A
	Subtotal	730	729	99.9%	0.0	14.2	1.9	B
Total		1910	1918	100.4%	0.2	43.5	6.8	D

Intersection

El Camino Real/Ralston Avenue

Signalized

Direction	Movement	Volume (veh/hr)			GEH	Total Delay (sec/veh)		
		Demand	Served	% Served		Average	Std. Dev.	LOS
NB	Left Turn	170	152	89.5%	1.4	168.7	8.5	F
	Through	960	794	82.7%	5.6	222.2	4.2	F
	Right Turn	190	164	86.3%	2.0	28.0	4.2	C
	Subtotal	1320	1110	84.1%	6.0	186.3	3.3	F
SB	Left Turn	410	331	80.6%	4.1	278.1	30.3	F
	Through	1040	816	78.4%	7.4	115.3	26.1	F
	Right Turn	80	61	75.8%	2.3	57.8	17.7	E
	Subtotal	1530	1207	78.9%	8.7	157.2	11.2	F
EB	Left Turn	210	202	96.3%	0.5	232.5	62.9	F
	Through	930	873	93.8%	1.9	214.6	66.3	F
	Right Turn	60	60	99.8%	0.0	226.0	68.2	F
	Subtotal	1200	1135	94.6%	1.9	218.4	65.8	F
WB	Left Turn	170	167	98.0%	0.3	65.9	4.3	E
	Through	690	692	100.3%	0.1	58.1	4.2	E
	Right Turn	230	233	101.4%	0.2	12.6	1.2	B
	Subtotal	1090	1092	100.1%	0.0	49.6	3.1	D
Total		5140	4543	88.4%	8.6	153.6	16.4	F

Intersection

El Camino Real/Atherton Avenue-Fair Oaks Lane

Signalized

Direction	Movement	Volume (veh/hr)			GEH	Total Delay (sec/veh)		
		Demand	Served	% Served		Average	Std. Dev.	LOS
NB	Left Turn	120	93	77.3%	2.6	551.7	234.0	F
	Through	1620	1529	94.4%	2.3	35.9	5.4	D
	Right Turn	30	33	110.3%	0.6	35.9	4.0	D
	Subtotal	1770	1655	93.5%	2.8	64.8	17.8	E
SB	Left Turn	140	127	90.5%	1.2	311.7	88.4	F
	Through	1830	1761	96.2%	1.6	91.9	25.8	F
	Right Turn	190	193	101.5%	0.2	104.9	24.5	F
	Subtotal	2160	2080	96.3%	1.7	106.6	28.8	F
EB	Left Turn	120	96	80.3%	2.3	329.8	24.7	F
	Through	180	141	78.3%	3.1	333.0	23.9	F
	Right Turn	200	155	77.5%	3.4	317.0	21.8	F
	Subtotal	500	392	78.5%	5.1	325.9	22.7	F
WB	Left Turn	80	75	93.1%	0.6	156.8	75.7	F
	Through	150	148	98.9%	0.1	145.7	66.5	F
	Right Turn	70	75	106.6%	0.5	115.2	73.9	F
	Subtotal	300	297	99.1%	0.2	140.7	70.6	F
Total		4730	4425	93.5%	4.5	112.7	13.4	F

Intersection

El Camino Real/Watkins Avenue

Unsignalized

Direction	Movement	Volume (veh/hr)			GEH	Total Delay (sec/veh)		
		Demand	Served	% Served		Average	Std. Dev.	LOS
NB	Left Turn							
	Through	1640	1620	98.8%	0.5	1.8	0.2	A
	Right Turn	80	79	98.3%	0.2	2.7	0.4	A
	Subtotal	1720	1699	98.8%	0.5	1.9	0.2	A
SB	Left Turn	70	62	88.6%	1.0	26.8	4.7	D
	Through	2040	1954	95.8%	1.9	5.3	0.3	A
	Right Turn							
	Subtotal	2110	2016	95.5%	2.1	5.9	0.4	A
EB	Left Turn							
	Through							
	Right Turn							
	Subtotal							
WB	Left Turn	80	33	41.6%	6.2	1354.9	194.7	F
	Through							
	Right Turn	130	53	40.5%	8.1	1372.3	259.9	F
	Subtotal	210	86	41.0%	10.2	1363.3	227.2	F
Total		4040	3801	94.1%	3.8	33.9	1.9	D

Intersection El Camino Real/Glenwood

Signalized

Direction	Movement	Volume (veh/hr)			GEH	Total Delay (sec/veh)		
		Demand	Served	% Served		Average	Std. Dev.	LOS
NB	Left Turn	70	69	98.6%	0.1	72.9	10.4	E
	Through	1040	1045	100.5%	0.2	39.2	1.4	D
	Right Turn	40	40	99.8%	0.0	27.5	2.8	C
	Subtotal	1150	1154	100.3%	0.1	40.9	1.6	D
SB	Left Turn	230	180	78.0%	3.5	173.4	28.8	F
	Through	1230	993	80.7%	7.1	194.1	39.2	F
	Right Turn							
	Subtotal	1460	1172	80.3%	7.9	190.8	37.2	F
EB	Left Turn	320	246	76.8%	4.4	205.7	8.5	F
	Through	210	169	80.7%	2.9	212.9	10.9	F
	Right Turn	280	217	77.4%	4.0	162.1	6.9	F
	Subtotal	810	632	78.0%	6.6	192.8	8.4	F
WB	Left Turn	100	100	99.8%	0.0	67.3	15.7	E
	Through	190	194	102.2%	0.3	68.2	14.2	E
	Right Turn	100	100	100.0%	0.0	34.0	11.8	C
	Subtotal	390	394	101.0%	0.2	59.3	13.8	E
Total		3810	3352	88.0%	7.7	123.6	10.4	F

Intersection El Camino Real/Oak Grove

Signalized

Direction	Movement	Volume (veh/hr)			GEH	Total Delay (sec/veh)		
		Demand	Served	% Served		Average	Std. Dev.	LOS
NB	Left Turn	100	100	100.0%	0.0	121.5	34.6	F
	Through	1020	1034	101.4%	0.4	20.5	1.5	C
	Right Turn	80	82	102.3%	0.2	8.2	1.6	A
	Subtotal	1200	1216	101.3%	0.5	28.2	4.6	C
SB	Left Turn	190	153	80.6%	2.8	119.4	13.0	F
	Through	1340	1058	79.0%	8.1	129.2	17.7	F
	Right Turn	80	65	81.1%	1.8	112.7	15.9	F
	Subtotal	1610	1276	79.3%	8.8	127.2	16.8	F
EB	Left Turn	70	66	94.7%	0.4	55.6	10.3	E
	Through	210	200	95.4%	0.7	57.5	9.7	E
	Right Turn	60	65	107.7%	0.6	28.4	10.1	C
	Subtotal	340	331	97.4%	0.5	51.4	9.7	D
WB	Left Turn	200	191	95.5%	0.6	104.8	14.3	F
	Through	240	226	94.0%	1.0	103.3	13.4	F
	Right Turn	60	53	88.0%	1.0	51.7	8.9	D
	Subtotal	500	469	93.9%	1.4	98.1	12.8	F
Total		3650	3292	90.2%	6.1	78.8	7.7	E

Intersection **El Camino Real/Santa Cruz Ave**

Signalized

Direction	Movement	Volume (veh/hr)			GEH	Total Delay (sec/veh)		
		Demand	Served	% Served		Average	Std. Dev.	LOS
NB	Left Turn							
	Through	1030	1065	103.4%	1.1	15.2	2.9	B
	Right Turn	50	52	103.6%	0.3	4.3	0.5	A
	Subtotal	1080	1117	103.4%	1.1	14.7	2.7	B
SB	Left Turn							
	Through	1500	1234	82.3%	7.2	47.2	4.4	D
	Right Turn	100	82	81.8%	1.9	24.5	2.9	C
	Subtotal	1600	1316	82.2%	7.4	45.8	4.3	D
EB	Left Turn	100	101	100.9%	0.1	56.6	21.8	E
	Through	70	67	96.1%	0.3	58.3	26.7	E
	Right Turn	270	268	99.3%	0.1	62.5	32.4	E
	Subtotal	440	436	99.1%	0.2	60.5	28.9	E
WB	Left Turn	190	194	102.0%	0.3	61.2	7.1	E
	Through	70	75	107.7%	0.6	56.0	10.6	E
	Right Turn	70	71	101.6%	0.1	43.7	10.8	D
	Subtotal	330	340	103.1%	0.6	56.5	7.9	E
Total		3450	3209	93.0%	4.2	38.2	5.1	D

Intersection **Merril St/Santa Cruz Ave**

Unsignalized

Direction	Movement	Volume (veh/hr)			GEH	Total Delay (sec/veh)		
		Demand	Served	% Served		Average	Std. Dev.	LOS
NB	Left Turn	190	190	100.2%	0.0	17.9	9.4	C
	Through	100	113	112.6%	1.2	16.4	8.4	C
	Right Turn	10	8	83.0%	0.6	12.5	8.8	B
	Subtotal	300	311	103.8%	0.6	17.2	8.9	C
SB	Left Turn	20	19	96.5%	0.2	15.1	6.6	C
	Through	30	32	105.0%	0.3	13.1	3.6	B
	Right Turn	90	92	101.8%	0.2	14.1	5.9	B
	Subtotal	140	142	101.7%	0.2	14.0	5.4	B
EB	Left Turn	60	61	101.3%	0.1	9.5	1.0	A
	Through	60	62	103.7%	0.3	10.2	0.9	B
	Right Turn							
	Subtotal	120	123	102.5%	0.3	9.8	0.8	A
WB	Left Turn	10	10	101.0%	0.0	9.4	5.2	A
	Through	50	49	97.8%	0.2	12.7	4.9	B
	Right Turn	30	33	108.3%	0.4	6.1	2.9	A
	Subtotal	90	92	101.7%	0.2	10.0	3.8	A
Total		650	668	102.8%	0.7	14.1	5.5	B

Intersection Ravenswood Ave/Laurel St

Signalized

Direction	Movement	Volume (veh/hr)			GEH	Total Delay (sec/veh)		
		Demand	Served	% Served		Average	Std. Dev.	LOS
NB	Left Turn	179	174	97.2%	0.4	32.6	6.6	C
	Through	74	73	98.4%	0.1	23.2	3.1	C
	Right Turn	32	29	89.7%	0.6	19.0	5.5	B
	Subtotal	285	275	96.6%	0.6	28.8	5.3	C
SB	Left Turn	347	199	57.2%	9.0	289.7	21.8	F
	Through	179	95	53.0%	7.2	292.0	24.5	F
	Right Turn	84	49	58.0%	4.3	284.0	22.3	F
	Subtotal	610	342	56.1%	12.3	289.4	22.3	F
EB	Left Turn	42	35	82.9%	1.2	79.8	13.4	E
	Through	905	799	88.3%	3.6	37.9	4.8	D
	Right Turn	116	100	85.8%	1.6	32.8	5.5	C
	Subtotal	1063	933	87.8%	4.1	38.9	4.4	D
WB	Left Turn	21	20	93.3%	0.3	84.2	27.3	F
	Through	705	668	94.7%	1.4	49.8	26.0	D
	Right Turn	189	172	90.9%	1.3	46.4	27.8	D
	Subtotal	915	859	93.9%	1.9	49.9	26.4	D
Total		2873	2410	83.9%	9.0	77.2	10.1	E

Intersection Hope Street/Evelyn Ave

Signalized

Direction	Movement	Volume (veh/hr)			GEH	Total Delay (sec/veh)		
		Demand	Served	% Served		Average	Std. Dev.	LOS
NB	Left Turn	20	23	113.5%	0.6	30.2	5.1	C
	Through							
	Right Turn	80	89	111.0%	1.0	6.4	1.1	A
	Subtotal	100	112	111.5%	1.1	11.1	0.6	B
SB	Left Turn							
	Through							
	Right Turn							
	Subtotal							
EB	Left Turn							
	Through	110	111	100.9%	0.1	1.3	0.4	A
	Right Turn	10	10	101.0%	0.0	0.4	0.2	A
	Subtotal	120	121	100.9%	0.1	1.3	0.4	A
WB	Left Turn	60	59	97.8%	0.2	1.8	0.8	A
	Through	600	604	100.6%	0.2	1.9	0.2	A
	Right Turn							
	Subtotal	660	662	100.4%	0.1	1.9	0.2	A
Total		880	895	101.7%	0.5	3.0	0.1	A

Intersection Castro Street/Villa Street

Signalized

Direction	Movement	Volume (veh/hr)			GEH	Total Delay (sec/veh)		
		Demand	Served	% Served		Average	Std. Dev.	LOS
NB	Left Turn	20	18	91.5%	0.4	73.3	31.7	E
	Through	190	191	100.3%	0.0	47.8	20.1	D
	Right Turn	160	165	102.9%	0.4	40.2	21.7	D
	Subtotal	370	374	101.0%	0.2	45.7	21.1	D
SB	Left Turn	170	172	101.4%	0.2	53.0	15.0	D
	Through	210	211	100.2%	0.0	37.0	6.5	D
	Right Turn	360	365	101.4%	0.3	32.7	8.6	C
	Subtotal	740	748	101.0%	0.3	38.7	7.8	D
EB	Left Turn	270	268	99.3%	0.1	59.2	14.1	E
	Through	270	271	100.5%	0.1	35.0	13.2	C
	Right Turn	10	11	108.0%	0.2	27.0	15.2	C
	Subtotal	550	550	100.1%	0.0	46.6	13.8	D
WB	Left Turn	60	58	97.0%	0.2	24.6	2.5	C
	Through	220	230	104.6%	0.7	17.1	1.2	B
	Right Turn	100	97	97.1%	0.3	12.2	1.0	B
	Subtotal	380	386	101.4%	0.3	17.0	1.1	B
Total		2040	2057	100.8%	0.4	38.1	6.9	D

SimTraffic Post-Processor
Average Results from 10 Runs
Volume and Delay by Movement

Caltrain Electrification
2040 Plus Project Conditions with Mitigation
AM Peak Hour

Intersection Frances St/Evelyn Ave

Signalized

Direction	Movement	Volume (veh/hr)			GEH	Total Delay (sec/veh)		
		Demand	Served	% Served		Average	Std. Dev.	LOS
NB	Left Turn	100	102	102.2%	0.2	25.8	2.3	C
	Through	50	53	105.0%	0.3	25.5	4.0	C
	Right Turn	10	10	99.0%	0.0	20.4	5.0	C
	Subtotal	160	165	102.9%	0.4	25.3	2.5	C
SB	Left Turn	270	222	82.1%	3.1	118.8	5.6	F
	Through	50	41	82.6%	1.3	117.1	5.9	F
	Right Turn	220	186	84.7%	2.4	101.8	4.8	F
	Subtotal	540	449	83.2%	4.1	111.6	4.9	F
EB	Left Turn	170	133	78.0%	3.0	457.5	68.9	F
	Through	320	261	81.5%	3.5	247.9	53.2	F
	Right Turn	30	27	89.3%	0.6	249.6	48.2	F
	Subtotal	520	420	80.8%	4.6	314.8	59.2	F
WB	Left Turn	40	39	97.8%	0.1	50.2	5.9	D
	Through	700	730	104.2%	1.1	20.0	1.9	B
	Right Turn	420	403	95.9%	0.8	18.8	2.5	B
	Subtotal	1160	1172	101.0%	0.3	20.6	2.0	C
Total		2380	2206	92.7%	3.6	95.1	10.3	F

Intersection Lawrence Expressway/Kifer Road

Signalized

Direction	Movement	Volume (veh/hr)			GEH	Total Delay (sec/veh)		
		Demand	Served	% Served		Average	Std. Dev.	LOS
NB	Left Turn	460	292	63.4%	8.7	184.7	4.0	F
	Through	5130	3281	64.0%	28.5	208.0	2.5	F
	Right Turn	720	450	62.6%	11.1	231.1	3.6	F
	Subtotal	6310	4023	63.8%	31.8	208.9	2.5	F
SB	Left Turn	280	173	61.8%	7.1	1010.0	58.5	F
	Through	1540	1096	71.2%	12.2	86.8	6.8	F
	Right Turn	410	296	72.1%	6.1	64.4	5.0	E
	Subtotal	2230	1565	70.2%	15.3	185.5	18.3	F
EB	Left Turn	220	197	89.4%	1.6	392.3	162.9	F
	Through	340	345	101.5%	0.3	75.6	4.4	E
	Right Turn	280	288	102.8%	0.5	2.2	0.2	A
	Subtotal	840	830	98.8%	0.4	124.3	34.3	F
WB	Left Turn	160	155	97.0%	0.4	86.5	5.7	F
	Through	840	760	90.5%	2.8	268.6	28.5	F
	Right Turn	170	149	87.8%	1.6	252.7	26.6	F
	Subtotal	1170	1064	91.0%	3.2	239.9	24.7	F
Total		10550	7482	70.9%	32.3	198.9	5.2	F

Intersection Lawrence Expressway/Reed Ave-Monroe St

Signalized

Direction	Movement	Volume (veh/hr)			GEH	Total Delay (sec/veh)		
		Demand	Served	% Served		Average	Std. Dev.	LOS
NB	Left Turn	220	139	63.3%	6.0	190.5	3.9	F
	Through	5460	3461	63.4%	29.9	120.6	2.3	F
	Right Turn	150	99	65.8%	4.6	97.6	4.5	F
	Subtotal	5830	3699	63.5%	30.9	122.6	2.2	F
SB	Left Turn	110	85	76.8%	2.6	68.5	17.8	E
	Through	1660	1310	78.9%	9.1	15.0	0.6	B
	Right Turn	210	166	79.0%	3.2	10.4	0.6	B
	Subtotal	1980	1560	78.8%	10.0	17.4	1.4	B
EB	Left Turn	490	391	79.8%	4.7	530.9	112.6	F
	Through	440	427	97.0%	0.6	111.9	11.6	F
	Right Turn	310	291	93.9%	1.1	15.7	9.2	B
	Subtotal	1240	1109	89.4%	3.8	234.9	46.5	F
WB	Left Turn	260	170	65.5%	6.1	320.7	85.6	F
	Through	320	216	67.5%	6.3	381.8	117.4	F
	Right Turn	360	193	53.6%	10.0	606.8	177.8	F
	Subtotal	940	580	61.6%	13.1	439.8	33.5	F
Total		9990	6948	69.6%	33.1	143.1	8.5	F

Intersection

El Camino Real/Railroad Avenue

Signalized

Direction	Movement	Volume (veh/hr)			GEH	Total Delay (sec/veh)		
		Demand	Served	% Served		Average	Std. Dev.	LOS
NB	Left Turn	330	317	96.0%	0.7	122.8	32.0	F
	Through	1720	1717	99.8%	0.1	18.2	1.3	B
	Right Turn	70	68	97.7%	0.2	19.7	1.9	B
	Subtotal	2120	2102	99.1%	0.4	34.1	5.5	C
SB	Left Turn	80	77	96.6%	0.3	52.0	15.4	D
	Through	640	631	98.6%	0.4	18.3	1.2	B
	Right Turn	160	163	101.8%	0.2	19.0	1.7	B
	Subtotal	880	871	99.0%	0.3	21.5	1.9	C
EB	Left Turn	10	12	118.0%	0.5	29.5	4.3	C
	Through	10	11	108.0%	0.2	22.4	8.6	C
	Right Turn	30	30	100.0%	0.0	8.0	1.0	A
	Subtotal	50	53	105.2%	0.4	15.6	2.2	B
WB	Left Turn	80	79	99.3%	0.1	31.9	3.0	C
	Through	20	21	105.5%	0.2	22.1	6.5	C
	Right Turn	60	64	105.8%	0.4	13.2	2.2	B
	Subtotal	160	164	102.5%	0.3	23.3	1.7	C
Total		3210	3190	99.4%	0.4	29.8	3.8	C

Intersection

Lick Avenue-Shadow Run Drive/Alma Avenue

Signalized

Direction	Movement	Volume (veh/hr)			GEH	Total Delay (sec/veh)		
		Demand	Served	% Served		Average	Std. Dev.	LOS
NB	Left Turn	40	38	94.8%	0.3	54.0	7.1	D
	Through	60	66	109.8%	0.7	56.3	7.3	E
	Right Turn	20	19	93.0%	0.3	32.5	10.7	C
	Subtotal	120	122	102.0%	0.2	52.1	6.8	D
SB	Left Turn	70	64	91.0%	0.8	65.2	5.0	E
	Through	10	11	110.0%	0.3	63.8	13.3	E
	Right Turn	140	137	97.6%	0.3	13.6	5.1	B
	Subtotal	220	211	96.0%	0.6	31.8	4.4	C
EB	Left Turn	220	219	99.4%	0.1	122.1	38.5	F
	Through	740	741	100.1%	0.0	14.9	1.5	B
	Right Turn	20	19	96.0%	0.2	12.8	3.8	B
	Subtotal	980	979	99.9%	0.0	39.1	10.3	D
WB	Left Turn	10	10	99.0%	0.0	115.9	15.7	F
	Through	930	917	98.6%	0.4	48.4	7.9	D
	Right Turn	700	707	101.0%	0.3	77.0	10.6	E
	Subtotal	1640	1634	99.6%	0.2	61.2	9.0	E
Total		2960	2946	99.5%	0.3	51.4	5.5	D

Intersection Main Street/Maple Street

Unsignalized

Direction	Movement	Volume (veh/hr)			GEH	Total Delay (sec/veh)		
		Demand	Served	% Served		Average	Std. Dev.	LOS
NB	Left Turn							
	Through	470	354	75.4%	5.7	27.8	1.5	D
	Right Turn							
	Subtotal	470	354	75.4%	5.7	27.8	1.5	D
SB	Left Turn							
	Through	310	306	98.6%	0.2	7.7	1.1	A
	Right Turn							
	Subtotal	310	306	98.6%	0.2	7.7	1.1	A
EB	Left Turn							
	Through							
	Right Turn							
	Subtotal							
WB	Left Turn							
	Through							
	Right Turn	20	18	91.5%	0.4	162.9	138.4	F
	Subtotal	20	18	91.5%	0.4	162.9	138.4	F
Total		800	679	84.8%	4.5	22.8	5.3	C

Intersection Main Street/Beech Street

Unsignalized

Direction	Movement	Volume (veh/hr)			GEH	Total Delay (sec/veh)		
		Demand	Served	% Served		Average	Std. Dev.	LOS
NB	Left Turn	140	113	80.4%	2.4	120.0	23.0	F
	Through	440	333	75.8%	5.4	122.1	25.8	F
	Right Turn							
	Subtotal	580	446	76.9%	5.9	121.6	24.6	F
SB	Left Turn							
	Through	380	357	93.8%	1.2	2.2	0.3	A
	Right Turn	100	100	99.6%	0.0	1.2	0.2	A
	Subtotal	480	456	95.0%	1.1	2.0	0.2	A
EB	Left Turn	30	31	104.7%	0.3	361.2	133.7	F
	Through							
	Right Turn	120	109	90.4%	1.1	316.9	136.4	F
	Subtotal	150	140	93.3%	0.8	326.9	136.8	F
WB	Left Turn							
	Through							
	Right Turn							
	Subtotal							
Total		1210	1042	86.1%	5.0	96.4	26.8	F

Intersection Main Street/Middlefield Road

Signalized

Direction	Movement	Volume (veh/hr)			GEH	Total Delay (sec/veh)		
		Demand	Served	% Served		Average	Std. Dev.	LOS
NB	Left Turn	50	35	70.6%	2.3	137.6	20.5	F
	Through	400	306	76.5%	5.0	84.7	2.7	F
	Right Turn	40	33	81.8%	1.2	38.4	9.6	D
	Subtotal	490	374	76.3%	5.6	85.8	3.7	F
SB	Left Turn	130	132	101.3%	0.1	63.7	3.4	E
	Through	240	245	102.1%	0.3	46.0	4.8	D
	Right Turn	50	52	103.4%	0.2	19.3	4.2	B
	Subtotal	420	429	102.0%	0.4	48.3	2.7	D
EB	Left Turn	80	75	93.6%	0.6	59.9	6.2	E
	Through	780	743	95.3%	1.3	73.7	8.6	E
	Right Turn	50	47	93.2%	0.5	68.4	9.2	E
	Subtotal	910	865	95.0%	1.5	72.3	7.9	E
WB	Left Turn	20	15	76.5%	1.1	88.6	7.7	F
	Through	740	565	76.4%	6.9	11.2	0.6	B
	Right Turn	150	119	79.1%	2.7	5.2	1.4	A
	Subtotal	910	699	76.8%	7.4	11.9	0.9	B
Total		2730	2366	86.7%	7.2	52.2	3.3	D

Intersection Fair Oaks Lane/Middlefield Road

Signalized

Direction	Movement	Volume (veh/hr)			GEH	Total Delay (sec/veh)		
		Demand	Served	% Served		Average	Std. Dev.	LOS
NB	Left Turn	20	21	103.0%	0.1	31.5	4.7	C
	Through	10	10	99.0%	0.0	30.2	6.2	C
	Right Turn	300	295	98.2%	0.3	13.4	1.0	B
	Subtotal	330	325	98.5%	0.3	15.0	1.2	B
SB	Left Turn	20	20	101.0%	0.0	35.2	5.0	D
	Through	90	93	103.6%	0.3	27.0	3.8	C
	Right Turn	60	60	99.8%	0.0	18.3	3.5	B
	Subtotal	170	173	101.9%	0.3	24.9	2.8	C
EB	Left Turn	10	5	54.0%	1.7	208.0	28.5	F
	Through	750	452	60.3%	12.1	198.2	7.8	F
	Right Turn	260	162	62.2%	6.8	192.3	8.6	F
	Subtotal	1020	619	60.7%	14.0	196.7	7.9	F
WB	Left Turn	220	222	100.9%	0.1	117.2	27.1	F
	Through	630	616	97.8%	0.5	82.5	25.8	F
	Right Turn	20	20	97.5%	0.1	74.9	28.6	E
	Subtotal	870	858	98.6%	0.4	91.3	26.2	F
Total		2390	1976	82.7%	8.9	106.1	11.9	F

Intersection Watkins Avenue/Middlefield Road

Signalized

Direction	Movement	Volume (veh/hr)			GEH	Total Delay (sec/veh)		
		Demand	Served	% Served		Average	Std. Dev.	LOS
NB	Left Turn	70	75	106.7%	0.6	38.1	9.9	D
	Through							
	Right Turn	280	283	101.1%	0.2	22.9	7.2	C
	Subtotal	350	358	102.3%	0.4	26.1	7.8	C
SB	Left Turn							
	Through							
	Right Turn							
	Subtotal							
EB	Left Turn							
	Through	870	640	73.6%	8.4	12.4	1.3	B
	Right Turn	200	141	70.6%	4.5	9.9	1.0	A
	Subtotal	1070	781	73.0%	9.5	11.9	1.2	B
WB	Left Turn	90	89	99.0%	0.1	51.0	18.4	D
	Through	800	789	98.6%	0.4	33.9	20.3	C
	Right Turn							
	Subtotal	890	878	98.7%	0.4	35.6	20.1	D
Total		2310	2017	87.3%	6.3	24.7	10.1	C

Intersection

Linden Avenue-Glenwood Avenue/Middlefield Road

Signalized

Direction	Movement	Volume (veh/hr)			GEH	Total Delay (sec/veh)		
		Demand	Served	% Served		Average	Std. Dev.	LOS
NB	Left Turn	70	71	101.4%	0.1	69.6	14.4	E
	Through	10	9	94.0%	0.2	64.1	26.9	E
	Right Turn	220	222	100.7%	0.1	32.9	11.3	C
	Subtotal	300	302	100.6%	0.1	42.6	12.8	D
SB	Left Turn	60	55	91.0%	0.7	106.5	44.4	F
	Through	10	11	111.0%	0.3	115.1	62.2	F
	Right Turn	40	40	99.5%	0.0	79.4	40.8	E
	Subtotal	110	106	95.9%	0.4	97.0	42.9	F
EB	Left Turn	50	38	75.4%	1.9	80.0	7.1	E
	Through	770	622	80.7%	5.6	34.2	8.3	C
	Right Turn	330	273	82.7%	3.3	30.0	8.2	C
	Subtotal	1150	932	81.1%	6.8	34.8	8.0	C
WB	Left Turn	160	154	96.1%	0.5	121.4	24.2	F
	Through	780	767	98.3%	0.5	46.5	14.0	D
	Right Turn	10	9	93.0%	0.2	50.7	21.5	D
	Subtotal	950	930	97.9%	0.7	58.9	15.5	E
Total		2510	2269	90.4%	4.9	48.6	12.1	D

Intersection California Street/Rengstorff Avenue

Signalized

Direction	Movement	Volume (veh/hr)			GEH	Total Delay (sec/veh)		
		Demand	Served	% Served		Average	Std. Dev.	LOS
NB	Left Turn	280	160	57.2%	8.1	436.3	16.8	F
	Through	830	504	60.8%	12.6	471.1	13.8	F
	Right Turn	380	232	61.0%	8.5	510.1	16.5	F
	Subtotal	1490	896	60.2%	17.2	475.0	13.5	F
SB	Left Turn	130	124	95.5%	0.5	51.6	2.9	D
	Through	220	219	99.5%	0.1	52.2	2.9	D
	Right Turn	90	95	105.4%	0.5	39.8	3.5	D
	Subtotal	440	438	99.5%	0.1	49.3	1.8	D
EB	Left Turn	210	145	69.0%	4.9	248.6	6.0	F
	Through	770	535	69.4%	9.2	269.0	4.5	F
	Right Turn	180	125	69.6%	4.4	287.1	10.3	F
	Subtotal	1160	805	69.4%	11.3	268.1	3.9	F
WB	Left Turn	200	145	72.6%	4.2	248.1	5.9	F
	Through	740	520	70.3%	8.7	266.0	4.8	F
	Right Turn	240	181	75.2%	4.1	280.5	6.6	F
	Subtotal	1180	846	71.7%	10.5	266.0	4.1	F
Total		4270	2985	69.9%	21.3	297.5	4.0	F

Intersection

Pennsylvania Street/22nd Street

Signalized

Direction	Movement	Volume (veh/hr)			GEH	Total Delay (sec/veh)		
		Demand	Served	% Served		Average	Std. Dev.	LOS
NB	Left Turn	30	26	87.3%	0.7	11.8	1.4	B
	Through	240	244	101.5%	0.2	9.0	0.9	A
	Right Turn	10	11	111.0%	0.3	6.7	1.9	A
	Subtotal	280	281	100.4%	0.1	9.2	0.8	A
SB	Left Turn	100	101	101.0%	0.1	16.5	1.7	B
	Through	90	85	94.6%	0.5	12.1	1.7	B
	Right Turn	10	11	110.0%	0.3	8.5	4.9	A
	Subtotal	200	197	98.6%	0.2	14.1	1.4	B
EB	Left Turn	10	9	86.0%	0.5	16.1	5.1	B
	Through	60	62	103.0%	0.2	8.1	1.1	A
	Right Turn	130	123	94.2%	0.7	4.6	0.5	A
	Subtotal	200	193	96.5%	0.5	6.2	0.6	A
WB	Left Turn	10	10	104.0%	0.1	15.8	5.2	B
	Through	240	245	102.1%	0.3	11.3	0.7	B
	Right Turn	120	128	106.8%	0.7	8.2	0.8	A
	Subtotal	370	384	103.7%	0.7	10.4	0.6	B
Total		1050	1055	100.4%	0.1	10.0	0.5	A

Intersection

San Mateo Avenue/San Bruno Avenue

Signalized

Direction	Movement	Volume (veh/hr)			GEH	Total Delay (sec/veh)		
		Demand	Served	% Served		Average	Std. Dev.	LOS
NB	Left Turn	50	48	95.0%	0.4	33.4	5.1	C
	Through	120	121	101.1%	0.1	19.6	1.1	B
	Right Turn	200	205	102.4%	0.3	13.2	1.4	B
	Subtotal	370	374	100.9%	0.2	17.9	1.2	B
SB	Left Turn	130	122	93.9%	0.7	25.1	3.2	C
	Through	120	120	99.9%	0.0	21.2	2.4	C
	Right Turn	190	205	108.1%	1.1	16.6	2.9	B
	Subtotal	440	447	101.7%	0.3	20.2	2.6	C
EB	Left Turn	120	114	95.3%	0.5	66.8	6.8	E
	Through	530	539	101.6%	0.4	16.6	1.1	B
	Right Turn	30	35	117.0%	0.9	8.3	2.3	A
	Subtotal	680	688	101.2%	0.3	24.5	1.7	C
WB	Left Turn	140	140	100.1%	0.0	59.7	11.5	E
	Through	560	555	99.0%	0.2	29.6	4.3	C
	Right Turn	90	88	98.0%	0.2	25.3	4.8	C
	Subtotal	790	783	99.1%	0.3	34.6	4.0	C
Total		2280	2292	100.5%	0.2	26.1	1.9	C

Intersection

El Camino Real/Millbrae Avenue

Signalized

Direction	Movement	Volume (veh/hr)			GEH	Total Delay (sec/veh)		
		Demand	Served	% Served		Average	Std. Dev.	LOS
NB	Left Turn	50	48	96.6%	0.2	124.4	23.2	F
	Through	1130	1132	100.2%	0.1	42.9	1.5	D
	Right Turn	710	698	98.3%	0.4	5.4	0.5	A
	Subtotal	1890	1878	99.4%	0.3	31.1	1.4	C
SB	Left Turn	670	428	63.9%	10.3	316.3	11.2	F
	Through	1730	1133	65.5%	15.8	59.2	2.3	E
	Right Turn	70	48	68.9%	2.8	60.2	4.1	E
	Subtotal	2470	1609	65.1%	19.1	127.7	5.8	F
EB	Left Turn	140	124	88.4%	1.4	500.5	198.9	F
	Through	580	557	96.1%	0.9	154.7	59.8	F
	Right Turn	50	50	100.8%	0.1	122.1	46.3	F
	Subtotal	770	732	95.0%	1.4	211.8	80.7	F
WB	Left Turn	650	575	88.4%	3.0	72.1	5.4	E
	Through	730	650	89.1%	3.0	45.2	3.2	D
	Right Turn	820	717	87.4%	3.7	23.1	1.9	C
	Subtotal	2200	1942	88.3%	5.7	45.1	0.9	D
Total		7330	6161	84.1%	14.2	81.9	8.7	F

Intersection

Rollins Road/Millbrae Avenue

Signalized

Direction	Movement	Volume (veh/hr)			GEH	Total Delay (sec/veh)		
		Demand	Served	% Served		Average	Std. Dev.	LOS
NB	Left Turn	350	296	84.6%	3.0	59.3	2.0	E
	Through	110	88	80.3%	2.2	112.7	6.0	F
	Right Turn	740	636	85.9%	4.0	99.6	2.8	F
	Subtotal	1200	1020	85.0%	5.4	89.1	2.2	F
SB	Left Turn	460	474	103.0%	0.6	68.9	8.6	E
	Through	210	220	104.7%	0.7	59.7	2.8	E
	Right Turn	310	328	105.7%	1.0	30.2	7.1	C
	Subtotal	980	1021	104.2%	1.3	54.5	3.9	D
EB	Left Turn	200	164	82.1%	2.7	187.0	44.3	F
	Through	1510	1288	85.3%	5.9	99.0	17.3	F
	Right Turn	250	213	85.2%	2.4	66.4	17.3	E
	Subtotal	1960	1665	84.9%	6.9	103.6	18.6	F
WB	Left Turn	420	333	79.4%	4.5	379.4	61.9	F
	Through	1540	1311	85.1%	6.1	146.2	27.2	F
	Right Turn	390	338	86.7%	2.7	8.7	1.7	A
	Subtotal	2350	1983	84.4%	7.9	162.2	10.4	F
Total		6490	5689	87.7%	10.3	112.6	6.4	F

Intersection **California Drive/Oak Grove**

Signalized

Direction	Movement	Volume (veh/hr)			GEH	Total Delay (sec/veh)		
		Demand	Served	% Served		Average	Std. Dev.	LOS
NB	Left Turn	170	78	45.9%	8.3	531.3	123.5	F
	Through	750	349	46.5%	17.1	313.5	68.2	F
	Right Turn	250	89	35.8%	12.3	840.1	211.8	F
	Subtotal	1170	516	44.1%	22.5	437.3	53.1	F
SB	Left Turn	170	52	30.8%	11.2	1243.2	139.5	F
	Through	800	280	35.0%	22.4	155.7	19.7	F
	Right Turn	90	32	35.3%	7.5	51.8	16.6	D
	Subtotal	1060	365	34.4%	26.1	308.3	43.5	F
EB	Left Turn	30	2	6.7%	7.0	699.9	464.3	F
	Through	290	19	6.6%	21.8	2109.1	279.2	F
	Right Turn	80	5	5.9%	11.6	2138.4	607.8	F
	Subtotal	400	26	6.4%	25.7	2010.4	301.3	F
WB	Left Turn	210	100	47.6%	8.8	54.0	12.3	D
	Through	160	87	54.4%	6.6	22.0	3.3	C
	Right Turn	240	116	48.3%	9.3	11.0	1.5	B
	Subtotal	610	303	49.7%	14.4	28.4	4.0	C
Total		3240	1209	37.3%	43.1	326.3	26.8	F

Intersection **Carolan Ave/Oak Grove**

Signalized

Direction	Movement	Volume (veh/hr)			GEH	Total Delay (sec/veh)		
		Demand	Served	% Served		Average	Std. Dev.	LOS
NB	Left Turn	110	100	91.1%	1.0	196.8	75.9	F
	Through	130	128	98.6%	0.2	182.5	69.3	F
	Right Turn	50	48	96.6%	0.2	175.5	67.1	F
	Subtotal	290	277	95.4%	0.8	186.6	71.3	F
SB	Left Turn	160	51	31.9%	10.6	271.6	67.3	F
	Through	140	44	31.5%	10.0	273.9	45.4	F
	Right Turn	290	100	34.6%	13.6	709.3	147.7	F
	Subtotal	590	196	33.2%	19.9	498.5	110.2	F
EB	Left Turn	390	98	25.2%	18.7	39.1	3.2	D
	Through	130	31	23.8%	11.0	53.8	13.4	D
	Right Turn	190	51	26.8%	12.7	7.1	3.9	A
	Subtotal	710	180	25.4%	25.1	32.6	3.4	C
WB	Left Turn	90	37	40.6%	6.7	304.4	48.4	F
	Through	210	81	38.6%	10.7	327.0	38.8	F
	Right Turn	70	30	42.3%	5.7	282.8	41.0	F
	Subtotal	370	147	39.8%	13.9	312.0	37.3	F
Total		1960	800	40.8%	31.2	247.7	42.0	F

Intersection **California Dr/North Lane**

Unsignalized

Direction	Movement	Volume (veh/hr)			GEH	Total Delay (sec/veh)		
		Demand	Served	% Served		Average	Std. Dev.	LOS
NB	Left Turn							
	Through	990	477	48.1%	19.0	31.3	4.3	D
	Right Turn	120	59	49.1%	6.5	20.8	5.1	C
	Subtotal	1110	536	48.2%	20.0	30.2	4.0	D
SB	Left Turn	160	63	39.4%	9.2	11.4	8.6	B
	Through	970	390	40.2%	22.2	2.9	0.8	A
	Right Turn							
	Subtotal	1130	453	40.1%	24.1	4.1	1.2	A
EB	Left Turn							
	Through							
	Right Turn							
	Subtotal							
WB	Left Turn	60	15	24.7%	7.4	35.4	16.9	E
	Through							
	Right Turn	190	42	22.0%	13.8	153.3	33.3	F
	Subtotal	250	57	22.6%	15.6	121.1	20.9	F
Total		2490	1045	42.0%	34.4	23.6	2.0	C

Intersection **Carolan Ave/North Lane**

Unsignalized

Direction	Movement	Volume (veh/hr)			GEH	Total Delay (sec/veh)		
		Demand	Served	% Served		Average	Std. Dev.	LOS
NB	Left Turn	140	25	17.7%	12.7	1277.0	393.0	F
	Through	190	46	24.1%	13.3	508.5	165.4	F
	Right Turn	10	3	26.0%	2.9	434.6	298.5	F
	Subtotal	340	73	21.5%	18.6	758.0	241.2	F
SB	Left Turn	20	6	28.0%	4.0	358.9	320.0	F
	Through	270	82	30.3%	14.2	367.6	250.0	F
	Right Turn	110	25	22.8%	10.3	827.9	321.2	F
	Subtotal	400	112	28.1%	18.0	469.2	268.7	F
EB	Left Turn	90	39	43.4%	6.3	1.3	1.1	A
	Through	10	10	97.0%	0.1	0.6	0.3	A
	Right Turn	180	83	46.2%	8.4	0.6	0.3	A
	Subtotal	280	132	47.1%	10.3	0.8	0.4	A
WB	Left Turn							
	Through							
	Right Turn							
	Subtotal							
Total		1020	318	31.1%	27.2	320.6	86.3	F

Intersection **Railroad Ave/1st Ave**

Unsignalized

Direction	Movement	Volume (veh/hr)			GEH	Total Delay (sec/veh)		
		Demand	Served	% Served		Average	Std. Dev.	LOS
NB	Left Turn	30	30	100.0%	0.0	74.8	26.1	F
	Through	20	19	93.5%	0.3	61.3	35.1	F
	Right Turn	20	19	93.5%	0.3	41.4	26.0	E
	Subtotal	70	67	96.3%	0.3	61.4	26.9	F
SB	Left Turn							
	Through							
	Right Turn							
	Subtotal							
EB	Left Turn	10	8	78.0%	0.7	3.1	2.7	A
	Through	410	305	74.5%	5.5	0.8	0.4	A
	Right Turn							
	Subtotal	420	313	74.5%	5.6	0.9	0.4	A
WB	Left Turn							
	Through	340	194	57.1%	8.9	182.9	17.7	F
	Right Turn	10	7	72.0%	1.0	153.9	49.0	F
	Subtotal	350	201	57.5%	9.0	181.9	18.2	F
Total		840	582	69.3%	9.7	70.3	4.6	F

Intersection **S. B. St/1st Ave**

Signalized

Direction	Movement	Volume (veh/hr)			GEH	Total Delay (sec/veh)		
		Demand	Served	% Served		Average	Std. Dev.	LOS
NB	Left Turn	100	88	87.6%	1.3	61.1	7.2	E
	Through	520	443	85.2%	3.5	57.7	9.8	E
	Right Turn	80	68	85.4%	1.4	52.6	6.1	D
	Subtotal	700	599	85.6%	4.0	57.6	7.2	E
SB	Left Turn	90	69	76.1%	2.4	63.8	13.6	E
	Through	500	383	76.6%	5.6	46.5	5.2	D
	Right Turn	50	43	85.4%	1.1	43.2	9.9	D
	Subtotal	640	494	77.2%	6.1	48.6	6.3	D
EB	Left Turn	20	12	58.5%	2.1	143.8	31.7	F
	Through	270	184	68.3%	5.7	148.1	14.2	F
	Right Turn	70	44	62.1%	3.5	136.3	18.6	F
	Subtotal	360	240	66.5%	7.0	145.7	15.0	F
WB	Left Turn	60	34	57.3%	3.7	75.9	13.9	E
	Through	180	136	75.8%	3.5	56.2	5.5	E
	Right Turn	100	66	65.5%	3.8	46.4	8.4	D
	Subtotal	340	236	69.5%	6.1	56.3	6.2	E
Total		2040	1569	76.9%	11.1	67.6	2.5	E

Intersection

Transit Center Way/1st St

Unsignalized

Direction	Movement	Volume (veh/hr)			GEH	Total Delay (sec/veh)		
		Demand	Served	% Served		Average	Std. Dev.	LOS
NB	Left Turn	70	53	76.1%	2.1	102.2	17.4	F
	Through	20	13	64.5%	1.8	79.3	19.7	F
	Right Turn	70	47	67.4%	3.0	57.1	15.4	F
	Subtotal	160	113	70.9%	4.0	81.3	14.8	F
SB	Left Turn							
	Through							
	Right Turn							
	Subtotal							
EB	Left Turn	80	56	70.5%	2.9	18.7	4.6	C
	Through	350	270	77.1%	4.6	10.2	1.6	B
	Right Turn	10	7	67.0%	1.1	10.8	5.1	B
	Subtotal	440	333	75.7%	5.4	11.6	2.0	B
WB	Left Turn							
	Through	270	176	65.1%	6.3	34.5	7.4	D
	Right Turn	100	61	60.6%	4.4	18.8	11.2	C
	Subtotal	370	236	63.9%	7.7	30.4	8.2	D
Total		970	683	70.4%	10.0	29.4	3.0	D

Intersection **Railroad Avenue/9th Avenue**

Unsignalized

Direction	Movement	Volume (veh/hr)			GEH	Total Delay (sec/veh)		
		Demand	Served	% Served		Average	Std. Dev.	LOS
NB	Left Turn	50	48	95.8%	0.3	230.8	148.8	F
	Through							
	Right Turn	70	71	101.6%	0.1	198.7	126.6	F
	Subtotal	120	119	99.2%	0.1	211.4	135.1	F
SB	Left Turn							
	Through							
	Right Turn							
	Subtotal							
EB	Left Turn							
	Through	640	618	96.6%	0.9	2.2	0.3	A
	Right Turn	80	80	100.0%	0.0	0.6	0.2	A
	Subtotal	720	698	96.9%	0.8	2.0	0.3	A
WB	Left Turn	10	9	86.0%	0.5	34.6	21.0	D
	Through	620	620	99.9%	0.0	18.1	5.2	C
	Right Turn							
	Subtotal	630	628	99.7%	0.1	18.3	5.2	C
Total		1470	1445	98.3%	0.7	25.8	8.4	D

Intersection **S B Street/9th Avenue**

Signalized

Direction	Movement	Volume (veh/hr)			GEH	Total Delay (sec/veh)		
		Demand	Served	% Served		Average	Std. Dev.	LOS
NB	Left Turn	10	11	106.0%	0.2	54.9	20.2	D
	Through	270	270	99.9%	0.0	50.0	16.1	D
	Right Turn	170	162	95.5%	0.6	46.4	15.9	D
	Subtotal	450	443	98.4%	0.4	48.8	16.0	D
SB	Left Turn	110	97	87.7%	1.3	271.2	40.5	F
	Through	190	180	94.6%	0.8	50.1	14.7	D
	Right Turn	90	82	91.1%	0.9	43.3	14.0	D
	Subtotal	390	358	91.9%	1.6	108.8	26.5	F
EB	Left Turn	50	49	97.2%	0.2	58.7	21.3	E
	Through	440	439	99.8%	0.0	37.2	9.6	D
	Right Turn	20	21	105.5%	0.2	30.0	7.9	C
	Subtotal	510	509	99.8%	0.0	39.1	10.3	D
WB	Left Turn	130	125	95.8%	0.5	36.9	6.2	D
	Through	400	404	100.9%	0.2	17.5	2.5	B
	Right Turn	140	133	95.2%	0.6	13.8	2.1	B
	Subtotal	670	662	98.7%	0.3	20.5	2.6	C
Total		2020	1972	97.6%	1.1	47.7	6.1	D

Intersection El Camino Real/31st Street

Signalized

Direction	Movement	Volume (veh/hr)			GEH	Total Delay (sec/veh)		
		Demand	Served	% Served		Average	Std. Dev.	LOS
NB	Left Turn	170	161	94.6%	0.7	80.4	14.1	F
	Through	2050	1910	93.2%	3.1	43.4	3.9	D
	Right Turn	20	21	107.0%	0.3	22.1	7.1	C
	Subtotal	2240	2092	93.4%	3.2	46.1	4.0	D
SB	Left Turn	340	309	90.9%	1.7	174.7	10.9	F
	Through	2340	2085	89.1%	5.4	171.8	10.4	F
	Right Turn	170	153	89.9%	1.3	148.3	11.7	F
	Subtotal	2850	2547	89.4%	5.8	170.8	9.7	F
EB	Left Turn	260	252	96.9%	0.5	123.0	45.1	F
	Through	40	40	100.3%	0.0	138.8	47.6	F
	Right Turn	180	183	101.6%	0.2	9.1	2.5	A
	Subtotal	480	475	98.9%	0.2	80.7	29.3	F
WB	Left Turn	100	98	97.6%	0.2	43.3	3.7	D
	Through	40	39	97.8%	0.1	43.6	6.3	D
	Right Turn	20	21	103.5%	0.2	21.1	2.2	C
	Subtotal	160	157	98.4%	0.2	40.4	2.9	D
Total		5730	5272	92.0%	6.2	109.3	6.1	F

Intersection El Camino Real/Hillsdale Blvd

Signalized

Direction	Movement	Volume (veh/hr)			GEH	Total Delay (sec/veh)		
		Demand	Served	% Served		Average	Std. Dev.	LOS
NB	Left Turn							
	Through							
	Right Turn							
	Subtotal							
SB	Left Turn	720	636	88.3%	3.2	50.1	5.9	D
	Through							
	Right Turn	240	226	94.1%	0.9	9.3	1.5	A
	Subtotal	960	862	89.8%	3.3	39.4	4.3	D
EB	Left Turn							
	Through	1020	661	64.8%	12.4	98.0	1.9	F
	Right Turn	130	82	63.4%	4.6	51.8	3.6	D
	Subtotal	1150	743	64.6%	13.2	92.9	2.1	F
WB	Left Turn	330	306	92.8%	1.3	6.2	1.1	A
	Through	1180	1107	93.8%	2.2	6.6	0.4	A
	Right Turn							
	Subtotal	1510	1413	93.6%	2.5	6.5	0.4	A
Total		4460	3812	85.5%	10.1	77.4	1.4	E

Intersection

Curtiss Street/Hillsdale Blvd

Signalized

Direction	Movement	Volume (veh/hr)			GEH	Total Delay (sec/veh)		
		Demand	Served	% Served		Average	Std. Dev.	LOS
NB	Left Turn	80	83	104.1%	0.4	36.2	6.1	D
	Through	30	30	99.0%	0.1	35.1	7.7	D
	Right Turn	100	98	98.2%	0.2	13.2	3.6	B
	Subtotal	210	211	100.6%	0.1	25.3	4.6	C
SB	Left Turn	40	39	97.3%	0.2	30.8	8.9	C
	Through	10	10	100.0%	0.0	27.1	9.5	C
	Right Turn	30	31	101.7%	0.1	31.4	6.2	C
	Subtotal	80	79	99.3%	0.1	30.4	6.5	C
EB	Left Turn	10	8	76.0%	0.8	41.8	6.7	D
	Through	1360	1082	79.6%	7.9	12.8	1.2	B
	Right Turn	150	124	82.8%	2.2	11.2	1.2	B
	Subtotal	1520	1214	79.9%	8.3	12.8	1.2	B
WB	Left Turn	10	8	83.0%	0.6	77.6	29.8	E
	Through	1620	1490	92.0%	3.3	68.8	26.6	E
	Right Turn	40	39	96.8%	0.2	74.5	29.6	E
	Subtotal	1670	1537	92.0%	3.3	69.0	26.6	E
Total		3480	3042	87.4%	7.7	42.4	13.8	D

Intersection

El Camino Real/Ralston Avenue

Signalized

Direction	Movement	Volume (veh/hr)			GEH	Total Delay (sec/veh)		
		Demand	Served	% Served		Average	Std. Dev.	LOS
NB	Left Turn	100	74	74.3%	2.8	269.6	34.7	F
	Through	1190	929	78.1%	8.0	202.0	2.7	F
	Right Turn	230	179	77.7%	3.6	39.4	1.7	D
	Subtotal	1520	1182	77.8%	9.2	181.8	4.7	F
SB	Left Turn	450	311	69.2%	7.1	321.1	8.0	F
	Through	1250	878	70.2%	11.4	72.5	2.6	E
	Right Turn	150	107	71.3%	3.8	38.2	4.6	D
	Subtotal	1850	1296	70.1%	14.0	129.6	3.3	F
EB	Left Turn	280	200	71.4%	5.2	235.2	9.5	F
	Through	900	632	70.2%	9.7	259.0	9.5	F
	Right Turn	80	57	71.1%	2.8	271.1	11.9	F
	Subtotal	1260	889	70.5%	11.3	254.4	9.2	F
WB	Left Turn	290	297	102.3%	0.4	129.6	32.0	F
	Through	890	892	100.2%	0.1	51.3	7.6	D
	Right Turn	370	375	101.4%	0.3	32.6	3.8	C
	Subtotal	1550	1563	100.9%	0.3	61.7	9.7	E
Total		6180	4930	79.8%	16.8	143.0	3.4	F

Intersection California/Broadway

Unsignalized

Direction	Movement	Volume (veh/hr)			GEH	Total Delay (sec/veh)		
		Demand	Served	% Served		Average	Std. Dev.	LOS
NB	Left Turn	50	7	13.8%	8.1	1478.3	294.4	F
	Through	90	15	16.1%	10.4	1398.9	162.8	F
	Right Turn	230	30	12.8%	17.6	1425.7	247.1	F
	Subtotal	370	51	13.8%	22.0	1429.1	175.5	F
SB	Left Turn	120	22	18.6%	11.6	329.2	38.7	F
	Through	110	19	17.6%	11.3	220.3	45.0	F
	Right Turn	60	11	18.0%	8.3	231.3	29.7	F
	Subtotal	290	53	18.1%	18.1	269.4	34.6	F
EB	Left Turn	40	8	21.0%	6.4	192.7	33.0	F
	Through	1090	223	20.4%	33.9	206.3	39.8	F
	Right Turn	200	42	21.2%	14.3	191.8	29.5	F
	Subtotal	1330	273	20.5%	37.3	203.5	34.7	F
WB	Left Turn	360	81	22.6%	18.8	13.5	2.0	B
	Through	1090	242	22.2%	32.9	6.0	0.8	A
	Right Turn	140	37	26.4%	11.0	0.7	0.4	A
	Subtotal	1590	360	22.7%	39.4	7.2	0.9	A
Total		3580	737	20.6%	61.2	196.2	24.5	F

Intersection Arguello Street/Brewster Ave

Signalized

Direction	Movement	Volume (veh/hr)			GEH	Total Delay (sec/veh)		
		Demand	Served	% Served		Average	Std. Dev.	LOS
NB	Left Turn	150	43	28.5%	10.9	89.5	17.0	F
	Through	650	196	30.2%	22.0	75.0	16.9	E
	Right Turn	150	50	33.4%	10.0	34.4	10.1	C
	Subtotal	950	289	30.4%	26.5	70.1	15.5	E
SB	Left Turn	30	14	47.7%	3.3	416.0	83.0	F
	Through	460	182	39.7%	15.5	406.6	70.5	F
	Right Turn	210	86	41.1%	10.2	389.3	54.1	F
	Subtotal	700	283	40.4%	18.8	401.5	65.0	F
EB	Left Turn	110	85	77.4%	2.5	9.2	3.5	A
	Through	200	162	81.2%	2.8	9.2	1.6	A
	Right Turn	40	35	86.8%	0.9	2.6	2.3	A
	Subtotal	350	282	80.6%	3.8	8.4	1.3	A
WB	Left Turn	60	62	103.0%	0.2	54.7	9.0	D
	Through	450	450	99.9%	0.0	52.4	3.4	D
	Right Turn	50	52	104.4%	0.3	45.1	6.9	D
	Subtotal	560	564	100.6%	0.2	52.0	3.3	D
Total		2560	1418	55.4%	25.6	115.6	6.0	F

Intersection El Camino Real/Broadway

Signalized

Direction	Movement	Volume (veh/hr)			GEH	Total Delay (sec/veh)		
		Demand	Served	% Served		Average	Std. Dev.	LOS
NB	Left Turn	220	154	70.1%	4.8	174.6	19.4	F
	Through	1280	935	73.0%	10.4	126.4	5.0	F
	Right Turn	150	107	71.1%	3.8	170.6	41.8	F
	Subtotal	1650	1196	72.5%	12.0	136.9	6.6	F
SB	Left Turn	550	85	15.5%	26.1	693.7	148.5	F
	Through	1250	201	16.0%	39.0	43.1	7.7	D
	Right Turn	30	5	15.0%	6.1	7.7	6.1	A
	Subtotal	1830	290	15.8%	47.3	234.6	51.8	F
EB	Left Turn	20	3	13.5%	5.1	669.0	392.2	F
	Through	630	78	12.4%	29.3	903.3	122.4	F
	Right Turn	300	35	11.6%	20.5	660.2	143.7	F
	Subtotal	950	116	12.2%	36.1	828.6	123.6	F
WB	Left Turn	180	42	23.4%	13.1	55.1	5.8	E
	Through	890	196	22.0%	29.8	58.3	3.1	E
	Right Turn	130	29	22.2%	11.4	46.7	4.1	D
	Subtotal	1200	267	22.3%	34.4	56.6	3.1	E
Total		5630	1869	33.2%	61.4	181.5	9.4	F

Intersection Arguello St/Broadway

Signalized

Direction	Movement	Volume (veh/hr)			GEH	Total Delay (sec/veh)		
		Demand	Served	% Served		Average	Std. Dev.	LOS
NB	Left Turn	80	59	73.3%	2.6	291.2	57.5	F
	Through	220	164	74.7%	4.0	75.5	14.4	E
	Right Turn	360	264	73.3%	5.4	69.6	10.4	E
	Subtotal	660	487	73.8%	7.2	98.2	16.2	F
SB	Left Turn	90	43	47.7%	5.8	199.8	57.9	F
	Through	260	129	49.7%	9.4	163.6	47.2	F
	Right Turn	210	101	48.1%	8.7	152.1	46.4	F
	Subtotal	560	273	48.8%	14.1	165.3	48.4	F
EB	Left Turn	400	80	19.9%	20.7	24.9	4.9	C
	Through	940	186	19.8%	31.8	25.1	1.4	C
	Right Turn	100	19	19.0%	10.5	2.0	0.6	A
	Subtotal	1440	285	19.8%	39.3	23.4	2.2	C
WB	Left Turn	30	5	17.7%	5.9	297.1	71.0	F
	Through	1300	188	14.4%	40.8	293.8	64.2	F
	Right Turn	330	45	13.8%	20.8	124.9	21.4	F
	Subtotal	1660	238	14.4%	46.1	262.5	53.0	F
Total		4320	1283	29.7%	57.4	125.2	10.0	F

SimTraffic Post-Processor
Average Results from 20 Runs
Volume and Delay by Movement

Caltrain Electrification
2040 Plus Project Conditions with Mitigation
PM Peak Hour

Intersection

El Camino Real/James

Signalized

Direction	Movement	Volume (veh/hr)			GEH	Total Delay (sec/veh)		
		Demand	Served	% Served		Average	Std. Dev.	LOS
NB	Left Turn	137	92	67.2%	4.2	237.9	14.0	F
	Through	1558	1079	69.3%	13.2	232.0	13.5	F
	Right Turn	42	31	73.3%	1.9	145.3	9.5	F
	Subtotal	1737	1202	69.2%	14.0	230.3	12.7	F
SB	Left Turn	137	24	17.8%	12.5	57.6	7.4	E
	Through	1600	252	15.7%	44.3	16.5	2.9	B
	Right Turn	84	13	15.7%	10.2	6.6	2.7	A
	Subtotal	1821	289	15.9%	47.2	19.6	2.7	B
EB	Left Turn	95	85	88.9%	1.1	88.1	14.2	F
	Through	63	70	110.8%	0.8	25.4	2.9	C
	Right Turn	105	98	93.2%	0.7	4.7	0.5	A
	Subtotal	263	252	95.9%	0.7	38.5	6.3	D
WB	Left Turn	211	50	23.8%	14.1	35.2	3.7	D
	Through	411	99	24.1%	19.5	34.4	4.8	C
	Right Turn	84	17	20.2%	9.4	57.2	11.5	E
	Subtotal	706	167	23.6%	25.8	36.9	3.4	D
Total		4527	1910	42.2%	46.1	156.1	7.4	F

Intersection El Camino Real/Glenwood

Signalized

Direction	Movement	Volume (veh/hr)			GEH	Total Delay (sec/veh)		
		Demand	Served	% Served		Average	Std. Dev.	LOS
NB	Left Turn	200	142	71.1%	4.4	89.2	7.2	F
	Through	1550	1150	74.2%	10.9	66.9	8.5	E
	Right Turn	50	37	74.8%	1.9	54.3	12.9	D
	Subtotal	1800	1330	73.9%	11.9	68.9	8.0	E
SB	Left Turn	280	242	86.5%	2.3	228.1	31.8	F
	Through	1220	1117	91.6%	3.0	153.8	30.6	F
	Right Turn	380	344	90.4%	1.9	105.3	23.4	F
	Subtotal	1880	1703	90.6%	4.2	154.5	28.3	F
EB	Left Turn	430	277	64.3%	8.2	330.6	7.7	F
	Through	130	84	64.8%	4.4	330.6	11.3	F
	Right Turn	120	79	65.5%	4.2	251.0	7.9	F
	Subtotal	680	440	64.6%	10.2	316.4	8.6	F
WB	Left Turn	90	91	101.0%	0.1	164.1	62.2	F
	Through	250	244	97.6%	0.4	166.8	58.1	F
	Right Turn	110	110	100.4%	0.0	118.1	58.4	F
	Subtotal	450	445	99.0%	0.2	154.2	59.0	F
Total		4810	3918	81.4%	13.5	143.3	14.9	F

Intersection El Camino Real/Oak Grove

Signalized

Direction	Movement	Volume (veh/hr)			GEH	Total Delay (sec/veh)		
		Demand	Served	% Served		Average	Std. Dev.	LOS
NB	Left Turn	120	85	70.7%	3.5	45.1	5.7	D
	Through	1540	1145	74.4%	10.8	33.4	3.8	C
	Right Turn	110	78	70.8%	3.3	14.2	2.7	B
	Subtotal	1770	1308	73.9%	11.8	33.0	3.6	C
SB	Left Turn	340	291	85.5%	2.8	194.9	36.4	F
	Through	990	889	89.8%	3.3	49.8	7.0	D
	Right Turn	100	99	98.8%	0.1	12.2	2.1	B
	Subtotal	1430	1279	89.4%	4.1	80.3	13.9	F
EB	Left Turn	130	102	78.5%	2.6	341.2	32.0	F
	Through	250	195	77.8%	3.7	342.3	32.7	F
	Right Turn	150	116	77.3%	3.0	268.4	30.6	F
	Subtotal	530	413	77.8%	5.4	321.4	32.4	F
WB	Left Turn	180	91	50.4%	7.7	65.8	9.0	E
	Through	200	108	53.9%	7.4	61.3	9.5	E
	Right Turn	130	68	52.6%	6.2	22.5	5.4	C
	Subtotal	510	267	52.4%	12.3	52.9	8.0	D
Total		4240	3266	77.0%	15.9	89.3	6.4	F

Intersection El Camino Real/Santa Cruz Ave

Signalized

Direction	Movement	Volume (veh/hr)			GEH	Total Delay (sec/veh)		
		Demand	Served	% Served		Average	Std. Dev.	LOS
NB	Left Turn							
	Through	1530	1185	77.5%	9.4	31.2	2.3	C
	Right Turn	80	66	82.0%	1.7	31.6	10.3	C
	Subtotal	1610	1251	77.7%	9.5	31.2	2.4	C
SB	Left Turn							
	Through	1220	1018	83.4%	6.1	18.1	4.0	B
	Right Turn	100	80	80.0%	2.1	5.5	1.3	A
	Subtotal	1320	1098	83.2%	6.4	17.2	3.8	B
EB	Left Turn	180	84	46.6%	8.4	402.0	69.9	F
	Through	280	129	45.9%	10.6	540.8	134.3	F
	Right Turn	250	119	47.8%	9.6	322.8	69.3	F
	Subtotal	710	332	46.7%	16.6	429.1	97.8	F
WB	Left Turn	80	46	57.0%	4.3	76.9	11.2	E
	Through	280	169	60.2%	7.4	82.1	6.5	F
	Right Turn	60	36	59.8%	3.5	69.9	11.9	E
	Subtotal	420	250	59.5%	9.3	79.4	7.6	E
Total		4060	2930	72.2%	19.1	73.3	3.5	E

Intersection Merrill St/Santa Cruz Ave

Signalized

Direction	Movement	Volume (veh/hr)			GEH	Total Delay (sec/veh)		
		Demand	Served	% Served		Average	Std. Dev.	LOS
NB	Left Turn	220	145	66.0%	5.5	95.8	48.9	F
	Through	20	15	73.0%	1.3	88.3	41.7	F
	Right Turn	10	7	65.0%	1.2	83.1	65.6	F
	Subtotal	250	166	66.5%	5.8	94.5	48.6	F
SB	Left Turn	10	4	41.0%	2.2	274.1	90.4	F
	Through	270	118	43.9%	10.9	287.2	64.8	F
	Right Turn	150	62	41.6%	8.5	275.2	57.4	F
	Subtotal	430	185	43.0%	14.0	282.5	59.0	F
EB	Left Turn	250	137	54.8%	8.1	98.9	22.5	F
	Through	60	31	52.3%	4.2	99.6	15.5	F
	Right Turn	50	28	55.2%	3.6	122.3	30.4	F
	Subtotal	360	196	54.4%	9.8	102.4	20.3	F
WB	Left Turn	10	9	85.0%	0.5	212.8	163.3	F
	Through	50	47	94.2%	0.4	133.4	97.7	F
	Right Turn	40	39	98.5%	0.1	110.4	88.3	F
	Subtotal	100	95	95.0%	0.5	131.2	99.0	F
Total		1140	642	56.3%	16.7	153.4	19.1	F

Intersection Ravenswood Ave/Laurel St

Signalized

Direction	Movement	Volume (veh/hr)			GEH	Total Delay (sec/veh)		
		Demand	Served	% Served		Average	Std. Dev.	LOS
NB	Left Turn	200	181	90.3%	1.4	103.4	90.5	F
	Through	147	139	94.4%	0.7	69.8	73.5	E
	Right Turn	53	50	94.3%	0.4	62.6	64.7	E
	Subtotal	400	369	92.3%	1.6	85.4	80.3	F
SB	Left Turn	189	100	52.8%	7.4	395.9	57.7	F
	Through	137	72	52.7%	6.3	387.1	46.7	F
	Right Turn	200	97	48.6%	8.4	388.7	62.4	F
	Subtotal	526	269	51.2%	12.9	390.6	55.5	F
EB	Left Turn	147	93	63.2%	4.9	122.4	39.7	F
	Through	937	600	64.1%	12.1	27.0	5.1	C
	Right Turn	137	92	67.1%	4.2	24.5	5.5	C
	Subtotal	1221	785	64.3%	13.8	38.1	9.3	D
WB	Left Turn	42	34	81.7%	1.2	202.7	54.1	F
	Through	642	507	79.0%	5.6	179.3	50.1	F
	Right Turn	221	175	79.2%	3.3	177.0	54.2	F
	Subtotal	905	716	79.2%	6.6	179.9	50.9	F
Total		3052	2140	70.1%	17.9	136.7	26.7	F

Intersection Hope Street/Evelyn Ave

Signalized

Direction	Movement	Volume (veh/hr)			GEH	Total Delay (sec/veh)		
		Demand	Served	% Served		Average	Std. Dev.	LOS
NB	Left Turn	60	66	110.7%	0.8	18.4	1.9	B
	Through							
	Right Turn	190	191	100.6%	0.1	5.7	0.3	A
	Subtotal	250	258	103.0%	0.5	9.0	0.5	A
SB	Left Turn							
	Through							
	Right Turn							
	Subtotal							
EB	Left Turn							
	Through	150	104	69.3%	4.1	2.0	0.4	A
	Right Turn	20	17	82.5%	0.8	0.9	0.5	A
	Subtotal	170	120	70.8%	4.1	1.9	0.4	A
WB	Left Turn	80	79	98.9%	0.1	3.5	0.8	A
	Through	210	212	101.1%	0.2	2.6	0.4	A
	Right Turn							
	Subtotal	290	292	100.5%	0.1	2.8	0.3	A
Total		710	670	94.3%	1.5	5.0	0.3	A

Intersection Castro Street/Villa Street

Signalized

Direction	Movement	Volume (veh/hr)			GEH	Total Delay (sec/veh)		
		Demand	Served	% Served		Average	Std. Dev.	LOS
NB	Left Turn	40	39	96.8%	0.2	194.4	19.8	F
	Through	250	235	93.8%	1.0	175.0	19.8	F
	Right Turn	100	93	93.3%	0.7	165.0	20.9	F
	Subtotal	390	367	94.0%	1.2	174.6	18.8	F
SB	Left Turn	290	206	71.0%	5.3	179.6	5.9	F
	Through	320	231	72.0%	5.4	56.2	2.3	E
	Right Turn	220	156	71.0%	4.6	49.0	3.3	D
	Subtotal	830	593	71.4%	8.9	97.2	2.3	F
EB	Left Turn	580	321	55.4%	12.2	208.7	15.5	F
	Through	260	131	50.4%	9.2	169.0	11.5	F
	Right Turn	40	23	58.5%	2.9	168.1	16.1	F
	Subtotal	880	476	54.0%	15.5	195.7	14.0	F
WB	Left Turn	130	138	105.8%	0.6	25.7	1.9	C
	Through	330	337	102.0%	0.4	22.3	1.8	C
	Right Turn	70	72	102.9%	0.2	18.0	2.3	B
	Subtotal	530	546	103.0%	0.7	22.6	1.6	C
Total		2630	1981	75.3%	13.5	114.4	4.2	F

Intersection

Frances St/Evelyn Ave

Signalized

Direction	Movement	Volume (veh/hr)			GEH	Total Delay (sec/veh)		
		Demand	Served	% Served		Average	Std. Dev.	LOS
NB	Left Turn	30	28	93.3%	0.4	32.8	5.2	C
	Through	60	59	98.7%	0.1	30.0	4.4	C
	Right Turn	20	21	103.5%	0.2	20.7	5.5	C
	Subtotal	110	108	98.1%	0.2	29.1	3.6	C
SB	Left Turn	310	261	84.2%	2.9	71.2	5.6	E
	Through	60	51	84.8%	1.2	67.7	8.8	E
	Right Turn	190	168	88.3%	1.7	48.2	3.9	D
	Subtotal	560	480	85.7%	3.5	62.9	4.9	E
EB	Left Turn	150	93	61.9%	5.2	440.9	37.2	F
	Through	880	571	64.9%	11.5	171.4	15.5	F
	Right Turn	70	46	66.3%	3.1	165.1	18.2	F
	Subtotal	1100	711	64.6%	12.9	206.4	19.8	F
WB	Left Turn	80	77	95.9%	0.4	222.6	66.1	F
	Through	390	443	113.6%	2.6	25.6	8.9	C
	Right Turn	300	292	97.3%	0.5	21.1	8.9	C
	Subtotal	770	812	105.4%	1.5	42.9	13.2	D
Total		2540	2110	83.1%	8.9	101.4	6.9	F

Intersection

Lick Avenue-Shadow Run Drive/Alma Avenue

Signalized

Direction	Movement	Volume (veh/hr)			GEH	Total Delay (sec/veh)		
		Demand	Served	% Served		Average	Std. Dev.	LOS
NB	Left Turn	50	49	98.4%	0.1	68.5	6.7	E
	Through	20	22	108.5%	0.4	59.6	12.7	E
	Right Turn	10	12	123.0%	0.7	24.2	4.5	C
	Subtotal	80	83	104.0%	0.4	59.6	5.5	E
SB	Left Turn	540	383	70.9%	7.3	113.2	7.1	F
	Through	80	58	72.1%	2.7	80.3	8.8	F
	Right Turn	330	237	71.7%	5.5	62.5	5.3	E
	Subtotal	950	677	71.3%	9.6	92.7	5.7	F
EB	Left Turn	100	100	99.5%	0.1	100.8	9.9	F
	Through	980	1001	102.2%	0.7	46.0	7.2	D
	Right Turn	40	38	95.5%	0.3	48.7	9.0	D
	Subtotal	1120	1139	101.7%	0.6	50.8	7.2	D
WB	Left Turn	20	18	90.5%	0.4	122.4	15.8	F
	Through	940	938	99.8%	0.1	56.1	6.7	E
	Right Turn	110	113	102.6%	0.3	60.5	6.7	E
	Subtotal	1070	1069	99.9%	0.0	57.7	6.7	E
Total		3220	2969	92.2%	4.5	63.0	4.0	E

Intersection Fair Oaks Lane/Middlefield Road

Signalized

Direction	Movement	Volume (veh/hr)			GEH	Total Delay (sec/veh)		
		Demand	Served	% Served		Average	Std. Dev.	LOS
NB	Left Turn	30	27	91.3%	0.5	29.4	4.5	C
	Through	20	21	103.0%	0.1	29.3	4.9	C
	Right Turn	130	130	100.0%	0.0	16.9	5.7	B
	Subtotal	180	178	98.9%	0.1	20.2	4.6	C
SB	Left Turn	10	8	82.0%	0.6	29.6	4.8	C
	Through	20	19	92.5%	0.3	26.4	5.1	C
	Right Turn	10	11	108.0%	0.2	16.3	7.3	B
	Subtotal	40	38	93.8%	0.4	24.0	5.1	C
EB	Left Turn	20	18	90.0%	0.5	53.7	18.4	D
	Through	710	710	99.9%	0.0	42.9	19.1	D
	Right Turn	120	117	97.8%	0.2	38.5	17.6	D
	Subtotal	850	845	99.4%	0.2	42.5	18.8	D
WB	Left Turn	190	149	78.5%	3.1	119.0	41.5	F
	Through	1090	890	81.7%	6.3	69.8	31.5	E
	Right Turn	20	16	81.0%	0.9	61.9	24.2	E
	Subtotal	1300	1056	81.2%	7.1	76.6	32.6	E
Total		2370	2116	89.3%	5.4	56.9	19.3	E

Intersection Watkins Avenue/Middlefield Road

Signalized

Direction	Movement	Volume (veh/hr)			GEH	Total Delay (sec/veh)		
		Demand	Served	% Served		Average	Std. Dev.	LOS
NB	Left Turn	80	81	100.6%	0.1	53.1	17.4	D
	Through							
	Right Turn	160	161	100.5%	0.1	34.6	21.0	C
	Subtotal	240	241	100.5%	0.1	40.8	19.2	D
SB	Left Turn							
	Through							
	Right Turn							
	Subtotal							
EB	Left Turn							
	Through	690	686	99.5%	0.1	34.2	25.5	C
	Right Turn	160	159	99.5%	0.1	32.1	27.6	C
	Subtotal	850	846	99.5%	0.2	33.8	25.8	C
WB	Left Turn	160	131	82.1%	2.4	106.4	35.5	F
	Through	1220	1005	82.4%	6.4	67.7	42.7	E
	Right Turn							
	Subtotal	1380	1136	82.3%	6.9	72.2	41.7	E
Total		2470	2223	90.0%	5.1	53.6	18.0	D

Intersection

Linden Avenue-Glenwood Avenue/Middlefield Road

Signalized

Direction	Movement	Volume (veh/hr)			GEH	Total Delay (sec/veh)		
		Demand	Served	% Served		Average	Std. Dev.	LOS
NB	Left Turn	130	106	81.2%	2.2	453.1	77.1	F
	Through	50	42	83.4%	1.2	447.8	72.5	F
	Right Turn	240	197	82.0%	2.9	400.0	62.2	F
	Subtotal	420	344	81.9%	3.9	422.3	65.5	F
SB	Left Turn	20	23	114.0%	0.6	56.8	8.9	E
	Through	40	42	105.5%	0.3	52.3	11.1	D
	Right Turn	60	61	101.8%	0.1	37.6	8.4	D
	Subtotal	120	126	105.1%	0.5	46.0	9.3	D
EB	Left Turn	50	48	95.4%	0.3	265.3	139.1	F
	Through	670	667	99.6%	0.1	122.8	102.7	F
	Right Turn	130	128	98.8%	0.1	118.5	99.6	F
	Subtotal	850	843	99.2%	0.2	130.4	104.9	F
WB	Left Turn	120	99	82.5%	2.0	107.3	6.3	F
	Through	1190	970	81.5%	6.7	66.2	7.2	E
	Right Turn	90	70	77.9%	2.2	62.6	5.7	E
	Subtotal	1400	1139	81.4%	7.3	69.6	6.8	E
Total		2790	2452	87.9%	6.6	138.0	32.9	F

Intersection California Street/Rengstorff Avenue

Signalized

Direction	Movement	Volume (veh/hr)			GEH	Total Delay (sec/veh)		
		Demand	Served	% Served		Average	Std. Dev.	LOS
NB	Left Turn	170	148	87.3%	1.7	306.9	47.8	F
	Through	460	411	89.3%	2.4	338.2	53.3	F
	Right Turn	230	205	89.0%	1.7	368.7	63.2	F
	Subtotal	860	764	88.8%	3.4	340.3	54.6	F
SB	Left Turn	330	188	57.1%	8.8	313.9	8.5	F
	Through	870	492	56.6%	14.5	338.6	7.1	F
	Right Turn	560	312	55.7%	11.9	367.3	11.7	F
	Subtotal	1760	992	56.4%	20.7	342.9	7.5	F
EB	Left Turn	100	47	46.6%	6.2	356.7	22.2	F
	Through	640	307	47.9%	15.3	366.3	22.6	F
	Right Turn	430	226	52.5%	11.3	377.6	26.2	F
	Subtotal	1170	579	49.5%	20.0	369.8	22.4	F
WB	Left Turn	710	460	64.8%	10.3	224.3	2.9	F
	Through	450	315	70.0%	6.9	97.5	22.4	F
	Right Turn	290	197	67.8%	6.0	85.2	21.4	F
	Subtotal	1450	972	67.0%	13.8	155.3	9.9	F
Total		5240	3307	63.1%	29.6	291.6	12.8	F

ATTACHMENT H
VISSIM OUTPUT SHEETS



Existing Conditions



Intersection 1

4th Street/King Street

Signal

Direction	Movement	Volume (vph)		Percent Served	GEH	Total Delay (sec/veh)		
		Demand	Served			Average	Std. Dev.	LOS
NB	Left Turn	6	6	93.3%	0.2	25.8	32.4	C
	Through	51	59	115.7%	1.1	32.9	8.8	C
	Right Turn	33	32	96.4%	0.2	7.7	4.2	A
	Subtotal	90	96	107.1%	0.7	24.5	7.3	C
SB	Left Turn	63	65	103.0%	0.2	27.7	5.1	C
	Through	359	371	103.5%	0.6	26.4	6.1	C
	Right Turn	218	218	100.2%	0.0	14.9	6.1	B
	Subtotal	640	655	102.3%	0.6	23.0	5.4	C
EB	Left Turn	84	78	93.3%	0.6	192.4	70.0	F
	Through	1,471	1,459	99.2%	0.3	80.7	34.1	F
	Right Turn	1	1	120.0%	0.2	7.3	13.8	A
	Subtotal	1,556	1,539	98.9%	0.4	87.1	35.9	F
WB	Left Turn	32	34	105.0%	0.3	49.6	17.1	D
	Through	702	705	100.4%	0.1	24.7	2.3	C
	Right Turn	27	36	134.4%	1.7	21.4	11.0	C
	Subtotal	761	775	101.8%	0.5	25.7	2.4	C
Total		3,047	3,065	100.6%	0.3	56.6	18.7	E

Intersection 2

4th Street/Townsend Street

Signal

Direction	Movement	Volume (vph)		Percent Served	GEH	Total Delay (sec/veh)		
		Demand	Served			Average	Std. Dev.	LOS
NB	Left Turn	22	18	83.6%	0.8	49.7	22.6	D
	Through							
	Right Turn	159	153	96.4%	0.5	13.3	1.9	B
	Subtotal	181	172	94.9%	0.7	18.1	3.2	B
SB	Left Turn	148	148	99.9%	0.0	31.0	3.8	C
	Through	380	379	99.7%	0.1	27.7	2.7	C
	Right Turn	75	70	93.3%	0.6	36.8	8.7	D
	Subtotal	603	597	98.9%	0.3	29.5	2.8	C
EB	Left Turn							
	Through	359	333	92.7%	1.4	29.0	5.3	C
	Right Turn	126	129	102.2%	0.2	55.4	18.6	E
	Subtotal	485	462	95.2%	1.1	35.8	7.2	D
WB	Left Turn	152	149	98.2%	0.2	37.2	4.7	D
	Through	214	213	99.7%	0.0	14.9	2.4	B
	Right Turn							
	Subtotal	366	363	99.1%	0.2	23.9	3.4	C
Total		1,635	1,593	97.4%	1.1	28.9	1.8	C

VISSIM Post-Processor
Average Results from 10 Runs
Volume and Delay by Movement

Caltrain Electrification
Existing Conditions
PM Peak Hour

Intersection 1

4th Street/King Street

Signal

Direction	Movement	Volume (vph)		Percent Served	GEH	Total Delay (sec/veh)		
		Demand	Served			Average	Std. Dev.	LOS
NB	Left Turn	11	10	92.7%	0.2	31.4	11.2	C
	Through	92	87	94.9%	0.5	30.8	7.4	C
	Right Turn	52	52	99.8%	0.0	6.9	3.0	A
	Subtotal	155	149	96.4%	0.5	22.8	5.1	C
SB	Left Turn	58	55	95.5%	0.3	80.8	33.5	F
	Through	269	258	96.1%	0.7	43.3	5.1	D
	Right Turn	486	493	101.5%	0.3	30.2	4.0	C
	Subtotal	813	807	99.3%	0.2	38.7	4.0	D
EB	Left Turn	137	123	89.8%	1.2	182.3	35.8	F
	Through	1,366	1,353	99.0%	0.4	144.3	38.5	F
	Right Turn	10	10	97.0%	0.1	72.8	38.2	E
	Subtotal	1,513	1,486	98.2%	0.7	146.8	37.4	F
WB	Left Turn	29	30	103.1%	0.2	47.3	13.5	D
	Through	988	975	98.7%	0.4	35.4	4.7	D
	Right Turn	35	33	94.3%	0.3	21.1	8.3	C
	Subtotal	1,052	1,038	98.6%	0.4	35.2	4.6	D
Total		3,533	3,480	98.5%	0.9	84.5	16.3	F

Intersection 2

4th Street/Townsend Street

Signal

Direction	Movement	Volume (vph)		Percent Served	GEH	Total Delay (sec/veh)		
		Demand	Served			Average	Std. Dev.	LOS
NB	Left Turn	16	12	76.3%	1.0	66.2	31.7	E
	Through							
	Right Turn	218	202	92.4%	1.1	20.2	5.3	C
	Subtotal	234	214	91.3%	1.4	23.0	7.4	C
SB	Left Turn	116	113	97.0%	0.3	35.1	7.4	D
	Through	497	487	98.0%	0.4	34.4	10.1	C
	Right Turn	89	86	96.4%	0.3	59.1	29.0	E
	Subtotal	702	686	97.6%	0.6	38.0	10.7	D
EB	Left Turn							
	Through	292	266	91.2%	1.5	25.3	4.1	C
	Right Turn	126	132	104.4%	0.5	28.3	5.4	C
	Subtotal	418	398	95.2%	1.0	26.5	3.2	C
WB	Left Turn	226	224	99.2%	0.1	30.0	3.3	C
	Through	307	308	100.4%	0.1	13.5	2.8	B
	Right Turn							
	Subtotal	533	532	99.8%	0.0	20.4	2.7	C
Total		1,887	1,829	96.9%	1.3	28.8	4.6	C

Intersection 5

7th Street/16th Street

Signal

Direction	Movement	Volume (vph)		Percent Served	GEH	Total Delay (sec/veh)		
		Demand	Served			Average	Std. Dev.	LOS
NB	Left Turn	49	49	99.4%	0.0	73.5	40.7	E
	Through	383	383	100.0%	0.0	76.6	34.7	E
	Right Turn	106	104	98.2%	0.2	57.7	36.7	E
	Subtotal	538	536	99.6%	0.1	72.2	35.5	E
SB	Left Turn	119	117	98.0%	0.2	99.9	13.8	F
	Through	97	94	96.8%	0.3	54.6	36.8	D
	Right Turn	39	42	107.2%	0.4	31.7	18.2	C
	Subtotal	255	252	98.9%	0.2	71.6	19.7	E
EB	Left Turn	35	37	105.4%	0.3	93.3	25.6	F
	Through	374	372	99.5%	0.1	90.4	28.3	F
	Right Turn	80	82	102.8%	0.2	77.4	35.2	E
	Subtotal	489	491	100.5%	0.1	88.9	28.1	F
WB	Left Turn	20	19	93.5%	0.3	48.4	25.7	D
	Through	213	220	103.1%	0.5	34.0	6.5	C
	Right Turn	160	168	105.3%	0.7	26.1	7.9	C
	Subtotal	393	407	103.5%	0.7	31.6	5.7	C
Total		1,675	1,686	100.7%	0.3	67.3	10.4	E

Intersection 6

16th Street/Owens Street

Signal

Direction	Movement	Volume (vph)		Percent Served	GEH	Total Delay (sec/veh)		
		Demand	Served			Average	Std. Dev.	LOS
NB	Left Turn							
	Through							
	Right Turn							
	Subtotal							
SB	Left Turn	51	52	102.5%	0.2	20.4	3.3	C
	Through							
	Right Turn	105	102	97.0%	0.3	6.0	0.6	A
	Subtotal	156	154	98.8%	0.2	10.9	1.3	B
EB	Left Turn	240	246	102.6%	0.4	19.8	7.3	B
	Through	349	346	99.1%	0.2	3.5	1.0	A
	Right Turn							
	Subtotal	589	592	100.5%	0.1	10.3	3.7	B
WB	Left Turn							
	Through	287	306	106.5%	1.1	12.2	1.7	B
	Right Turn	119	129	108.3%	0.9	8.1	1.6	A
	Subtotal	406	435	107.0%	1.4	10.9	1.3	B
Total		1,151	1,181	102.6%	0.9	10.6	2.1	B

VISSIM Post-Processor
Average Results from 10 Runs
Volume and Delay by Movement

Caltrain Electrification
Existing No Project
PM Peak Hour

Intersection 5

7th Street/16th Street

Signal

Direction	Movement	Volume (vph)		Percent Served	GEH	Total Delay (sec/veh)		
		Demand	Served			Average	Std. Dev.	LOS
NB	Left Turn	71	68	95.1%	0.4	47.9	13.1	D
	Through	329	332	101.0%	0.2	52.4	8.3	D
	Right Turn	40	39	97.0%	0.2	30.3	10.6	C
	Subtotal	440	439	99.7%	0.1	49.8	7.9	D
SB	Left Turn	75	83	110.7%	0.9	95.8	16.4	F
	Through	138	130	94.3%	0.7	83.4	32.2	F
	Right Turn	35	34	98.3%	0.1	54.5	22.6	D
	Subtotal	248	248	99.8%	0.0	83.9	18.1	F
EB	Left Turn	47	47	100.0%	0.0	86.5	31.4	F
	Through	326	318	97.4%	0.5	60.6	14.0	E
	Right Turn	75	74	98.3%	0.2	43.8	19.4	D
	Subtotal	448	438	97.8%	0.5	60.5	16.0	E
WB	Left Turn	58	59	102.4%	0.2	44.9	13.6	D
	Through	320	321	100.3%	0.1	26.5	5.0	C
	Right Turn	290	292	100.6%	0.1	34.0	8.9	C
	Subtotal	668	672	100.6%	0.2	31.4	6.1	C
Total		1,804	1,797	99.6%	0.2	49.5	2.8	D

Intersection 6

16th Street/Owens Street

Signal

Direction	Movement	Volume (vph)		Percent Served	GEH	Total Delay (sec/veh)		
		Demand	Served			Average	Std. Dev.	LOS
NB	Left Turn							
	Through							
	Right Turn							
	Subtotal							
SB	Left Turn	93	91	97.6%	0.2	14.6	3.1	B
	Through							
	Right Turn	170	169	99.4%	0.1	8.3	1.4	A
	Subtotal	263	260	98.7%	0.2	10.6	1.7	B
EB	Left Turn	108	106	98.5%	0.2	18.1	4.8	B
	Through	333	331	99.4%	0.1	4.9	2.1	A
	Right Turn							
	Subtotal	441	437	99.2%	0.2	8.2	2.4	A
WB	Left Turn							
	Through	498	503	100.9%	0.2	12.9	1.4	B
	Right Turn	82	75	92.0%	0.7	10.2	2.3	B
	Subtotal	580	578	99.6%	0.1	12.5	1.4	B
Total		1,284	1,275	99.3%	0.3	10.7	1.4	B

Intersection 18

California/Broadway

Signal

Direction	Movement	Volume (vph)		Percent Served	Total Delay (sec/veh)		
		Demand	Served		Average	Std. Dev.	LOS
NB	Left Turn	27	26	95.9%	90.2	20.6	F
	Through	277	283	102.2%	65.0	6.2	E
	Right Turn	490	483	98.5%	17.7	3.8	B
	Subtotal	794	792	99.7%	38.3	3.3	D
SB	Left Turn	436	429	98.5%	140.6	9.2	F
	Through	339	327	96.6%	127.9	11.3	F
	Right Turn	27	23	84.1%	127.2	20.6	F
	Subtotal	802	780	97.2%	134.9	8.5	F
EB	Left Turn	8	7	86.3%	46.4	41.1	D
	Through	379	380	100.2%	48.9	4.8	D
	Right Turn	31	32	101.6%	26.1	11.5	C
	Subtotal	418	418	100.0%	47.1	4.6	D
WB	Left Turn	241	238	98.7%	18.6	1.7	B
	Through	277	269	97.1%	8.3	0.9	A
	Right Turn	256	261	102.0%	1.4	0.5	A
	Subtotal	774	768	99.2%	8.8	0.8	A
Total		2,788	2,757	98.9%	60.0	1.8	E

Intersection 19

Carolan/Broadway

Signal

Direction	Movement	Volume (vph)		Percent Served	Total Delay (sec/veh)		
		Demand	Served		Average	Std. Dev.	LOS
NB	Left Turn	97	96	98.8%	111.3	23.2	F
	Through	1	0	0.0%			
	Right Turn	397	398	100.4%	18.4	5.3	B
	Subtotal	495	494	99.8%	36.1	6.2	D
SB	Left Turn						
	Through						
	Right Turn						
	Subtotal						
EB	Left Turn	1	1	70.0%	7.2	16.1	A
	Through	1,144	1,130	98.8%	1.4	0.2	A
	Right Turn	160	160	100.3%	2.1	1.2	A
	Subtotal	1,305	1,291	98.9%	1.5	0.2	A
WB	Left Turn	103	108	104.4%	66.4	8.7	E
	Through	676	671	99.3%	24.1	4.6	C
	Right Turn						
	Subtotal	779	779	99.9%	29.3	4.2	C
Total		2,579	2,564	99.4%	16.6	1.9	B

VISSIM Post-Processor
Average Results from 10 Runs
Volume and Delay by Movement

Caltrain Electrification
Existing Conditions
PM Peak Hour

Intersection 18

California/Broadway

Signal

Direction	Movement	Volume (vph)		Percent Served	Total Delay (sec/veh)		
		Demand	Served		Average	Std. Dev.	LOS
NB	Left Turn	31	30	96.8%	77.5	10.9	E
	Through	339	340	100.1%	60.0	7.0	E
	Right Turn	337	336	99.8%	10.4	2.8	B
	Subtotal	707	706	99.8%	37.8	4.8	D
SB	Left Turn	397	385	96.9%	135.9	20.9	F
	Through	334	323	96.6%	132.7	27.2	F
	Right Turn	38	33	86.8%	122.7	33.3	F
	Subtotal	769	740	96.3%	134.1	23.7	F
EB	Left Turn	11	10	90.0%	59.6	40.7	E
	Through	286	288	100.7%	58.4	5.7	E
	Right Turn	46	46	100.4%	42.0	18.9	D
	Subtotal	343	344	100.3%	56.8	5.6	E
WB	Left Turn	357	315	88.3%	14.4	0.9	B
	Through	477	432	90.6%	6.5	1.1	A
	Right Turn	353	330	93.3%	2.0	0.6	A
	Subtotal	1,187	1,077	90.7%	7.3	0.4	A
Total		3,006	2,867	95.4%	52.5	6.0	D

Intersection 19

Carolan/Broadway

Signal

Direction	Movement	Volume (vph)		Percent Served	Total Delay (sec/veh)		
		Demand	Served		Average	Std. Dev.	LOS
NB	Left Turn	86	87	100.7%	133.9	46.7	F
	Through	1	1	120.0%	29.4	93.1	C
	Right Turn	311	311	100.0%	10.5	2.8	B
	Subtotal	398	399	100.2%	37.5	10.4	D
SB	Left Turn						
	Through						
	Right Turn						
	Subtotal						
EB	Left Turn	1	1	60.0%	2.1	6.6	A
	Through	915	906	99.0%	1.9	0.7	A
	Right Turn	104	102	98.4%	2.1	0.9	A
	Subtotal	1,020	1,009	98.9%	1.9	0.6	A
WB	Left Turn	195	167	85.5%	161.7	31.3	F
	Through	1,101	989	89.8%	70.4	22.2	E
	Right Turn	1	1	80.0%	19.3	36.0	B
	Subtotal	1,297	1,157	89.2%	83.6	20.6	F
Total		2,715	2,564	94.4%	42.1	9.7	D

Intersection 45

El Camino Real/Whipple Road

Signal

Direction	Movement	Volume (vph)		Percent Served	GEH	Total Delay (sec/veh)		
		Demand	Served			Average	Std. Dev.	LOS
NB	Left Turn	55	55	99.1%	0.1	55.4	9.5	E
	Through	778	777	99.8%	0.0	29.0	5.1	C
	Right Turn	440	444	101.0%	0.2	15.7	5.1	B
	Subtotal	1,273	1,276	100.2%	0.1	25.7	4.9	C
SB	Left Turn	297	300	100.9%	0.2	259.0	70.4	F
	Through	828	822	99.3%	0.2	29.5	13.4	C
	Right Turn	60	62	104.0%	0.3	25.4	13.8	C
	Subtotal	1,185	1,184	99.9%	0.0	86.5	23.6	F
EB	Left Turn	100	89	89.4%	1.1	265.6	49.5	F
	Through	438	392	89.5%	2.2	262.5	36.4	F
	Right Turn	48	44	90.6%	0.7	255.1	44.0	F
	Subtotal	586	525	89.6%	2.6	262.2	38.8	F
WB	Left Turn	284	282	99.3%	0.1	34.7	5.0	C
	Through	287	280	97.5%	0.4	31.8	4.6	C
	Right Turn	204	208	102.1%	0.3	12.1	2.2	B
	Subtotal	775	770	99.4%	0.2	27.7	3.4	C
Total		3,819	3,755	98.3%	1.0	74.7	11.0	E

Intersection 62

Palo Alto/Alma

Side-street Stop

Direction	Movement	Volume (vph)		Percent Served	GEH	Total Delay (sec/veh)		
		Demand	Served			Average	Std. Dev.	LOS
NB	Left Turn							
	Through							
	Right Turn							
	Subtotal							
SB	Left Turn	9	8	88.9%	0.3	4.8	1.9	A
	Through							
	Right Turn	19	17	88.9%	0.5	13.2	10.7	B
	Subtotal	28	25	88.9%	0.6	11.2	9.1	B
EB	Left Turn							
	Through	482	468	97.1%	0.6	8.4	2.5	A
	Right Turn							
	Subtotal	482	468	97.1%	0.6	8.4	2.5	A
WB	Left Turn							
	Through	491	487	99.1%	0.2	7.9	2.4	A
	Right Turn	14	15	108.6%	0.3	5.3	6.8	A
	Subtotal	505	502	99.4%	0.1	7.8	2.4	A
Total		1,015	995	98.0%	0.6	8.2	2.1	A

VISSIM Post-Processor
Average Results from 10 Runs
Volume and Delay by Movement

Caltrain Electrification
Existing Conditions
AM Peak Hour

Intersection 64

El Camino Real/Sand Hill-Palo Alto

Signal

Direction	Movement	Volume (vph)		Percent Served	GEH	Total Delay (sec/veh)		
		Demand	Served			Average	Std. Dev.	LOS
NB	Left Turn	138	136	98.8%	0.1	60.5	6.7	E
	Through	564	575	102.0%	0.5	41.0	2.4	D
	Right Turn	24	25	102.1%	0.1	13.6	6.6	B
	Subtotal	726	736	101.4%	0.4	44.0	2.4	D
SB	Left Turn	458	442	96.6%	0.7	269.7	86.4	F
	Through	1,329	1,363	102.6%	0.9	40.8	3.8	D
	Right Turn	442	416	94.1%	1.3	25.8	5.3	C
	Subtotal	2,229	2,221	99.6%	0.2	85.9	20.8	F
EB	Left Turn	274	274	100.0%	0.0	51.9	7.6	D
	Through							
	Right Turn	225	223	99.2%	0.1	9.1	1.4	A
	Subtotal	499	497	99.6%	0.1	32.5	4.8	C
WB	Left Turn							
	Through							
	Right Turn	510	504	98.8%	0.3	3.5	1.0	A
	Subtotal	510	504	98.8%	0.3	3.5	1.0	A
Total		3,964	3,958	99.8%	0.1	60.7	12.0	E

Intersection 45

El Camino Real/Whipple Road

Signal

Direction	Movement	Volume (vph)		Percent Served	GEH	Total Delay (sec/veh)		
		Demand	Served			Average	Std. Dev.	LOS
NB	Left Turn	48	48	99.0%	0.1	58.2	9.8	E
	Through	1,234	1,247	101.1%	0.4	24.0	2.6	C
	Right Turn	258	251	97.2%	0.5	14.8	3.3	B
	Subtotal	1,540	1,546	100.4%	0.1	23.5	2.7	C
SB	Left Turn	199	193	97.1%	0.4	243.6	100.6	F
	Through	880	883	100.3%	0.1	22.9	2.6	C
	Right Turn	95	98	103.4%	0.3	21.0	5.9	C
	Subtotal	1,174	1,174	100.0%	0.0	60.9	19.2	E
EB	Left Turn	121	115	94.8%	0.6	144.9	31.6	F
	Through	222	228	102.5%	0.4	139.1	34.8	F
	Right Turn	54	53	97.6%	0.2	138.8	39.9	F
	Subtotal	397	395	99.5%	0.1	140.8	33.1	F
WB	Left Turn	304	307	101.1%	0.2	38.5	5.3	D
	Through	323	313	96.8%	0.6	36.4	4.5	D
	Right Turn	316	308	97.4%	0.5	17.1	3.0	B
	Subtotal	943	928	98.4%	0.5	30.6	3.8	C
Total		4,054	4,043	99.7%	0.2	48.3	6.4	D

Intersection 62

Palo Alto/Alma

Side-street Stop

Direction	Movement	Volume (vph)		Percent Served	GEH	Total Delay (sec/veh)		
		Demand	Served			Average	Std. Dev.	LOS
NB	Left Turn							
	Through							
	Right Turn							
	Subtotal							
SB	Left Turn	6	6	91.7%	0.2	4.8	2.3	A
	Through							
	Right Turn	19	19	97.9%	0.1	17.7	5.8	C
	Subtotal	25	24	96.4%	0.2	14.6	4.9	B
EB	Left Turn							
	Through	527	532	101.0%	0.2	5.2	1.5	A
	Right Turn							
	Subtotal	527	532	101.0%	0.2	5.2	1.5	A
WB	Left Turn							
	Through	705	702	99.6%	0.1	7.0	1.0	A
	Right Turn	15	15	99.3%	0.0	5.6	7.6	A
	Subtotal	720	717	99.6%	0.1	6.9	1.0	A
Total		1,272	1,274	100.1%	0.1	6.4	0.9	A

Intersection 64

El Camino Real/Sand Hill-Palo Alto

Signal

Direction	Movement	Volume (vph)		Percent Served	GEH	Total Delay (sec/veh)		
		Demand	Served			Average	Std. Dev.	LOS
NB	Left Turn	142	145	102.3%	0.3	59.1	8.7	E
	Through	1,283	1,281	99.9%	0.0	54.8	8.6	D
	Right Turn	121	118	97.4%	0.3	33.7	9.3	C
	Subtotal	1,546	1,544	99.9%	0.0	53.6	8.2	D
SB	Left Turn	406	415	102.2%	0.4	171.2	76.9	F
	Through	967	964	99.7%	0.1	36.4	3.0	D
	Right Turn	232	222	95.5%	0.7	11.4	2.2	B
	Subtotal	1,605	1,601	99.7%	0.1	68.5	21.2	E
EB	Left Turn	531	537	101.1%	0.3	53.6	8.9	D
	Through							
	Right Turn	228	226	98.9%	0.2	9.4	3.6	A
	Subtotal	759	762	100.4%	0.1	39.2	7.4	D
WB	Left Turn							
	Through							
	Right Turn	724	723	99.9%	0.0	4.7	1.7	A
	Subtotal	724	723	99.9%	0.0	4.7	1.7	A
Total		4,634	4,630	99.9%	0.1	49.1	7.0	D

Intersection 59

Alma Street/Ravenswood Ave

Side-street Stop

Direction	Movement	Volume (vph)		Percent Served	GEH	Total Delay (sec/veh)		
		Demand	Served			Average	Std. Dev.	LOS
NB	Left Turn	17	15	90.0%	0.4	28.5	7.9	D
	Through	3	3	100.0%	0.0	12.8	12.5	B
	Right Turn	3	3	86.7%	0.2	3.5	4.2	A
	Subtotal	23	21	90.9%	0.4	21.0	7.2	C
SB	Left Turn	5	3	62.0%	0.9	16.4	21.8	C
	Through	4	5	112.5%	0.2	26.7	25.0	D
	Right Turn	33	32	97.3%	0.2	23.0	9.3	C
	Subtotal	42	40	94.5%	0.4	23.4	6.5	C
EB	Left Turn	20	20	99.0%	0.0	42.7	22.3	E
	Through	677	676	99.9%	0.0	22.5	3.4	C
	Right Turn	203	210	103.6%	0.5	28.6	5.3	D
	Subtotal	900	906	100.7%	0.2	24.4	3.7	C
WB	Left Turn	3	2	73.3%	0.5	16.0	32.3	C
	Through	776	771	99.4%	0.2	20.9	4.7	C
	Right Turn	30	29	97.7%	0.1	14.6	7.3	B
	Subtotal	809	803	99.2%	0.2	20.7	4.6	C
Total		1,774	1,770	99.8%	0.1	22.6	3.4	C

Intersection 60

El Camino Real/Ravenswood Ave

Signal

Direction	Movement	Volume (vph)		Percent Served	GEH	Total Delay (sec/veh)		
		Demand	Served			Average	Std. Dev.	LOS
NB	Left Turn	81	81	99.5%	0.0	66.0	9.7	E
	Through	664	653	98.3%	0.4	33.9	3.9	C
	Right Turn	426	431	101.1%	0.2	17.0	3.5	B
	Subtotal	1,171	1,164	99.4%	0.2	30.0	3.1	C
SB	Left Turn	190	191	100.6%	0.1	75.2	7.7	E
	Through	1,333	1,314	98.6%	0.5	34.7	3.8	C
	Right Turn	21	23	109.0%	0.4	24.0	10.6	C
	Subtotal	1,544	1,528	99.0%	0.4	39.6	3.7	D
EB	Left Turn	14	12	87.1%	0.5	58.9	27.7	E
	Through	326	328	100.5%	0.1	59.5	5.9	E
	Right Turn	73	73	99.7%	0.0	35.5	8.4	D
	Subtotal	413	413	99.9%	0.0	55.1	6.3	E
WB	Left Turn	461	453	98.2%	0.4	45.3	6.7	D
	Through	230	227	98.7%	0.2	48.9	8.1	D
	Right Turn	60	60	100.3%	0.0	8.9	4.0	A
	Subtotal	751	740	98.5%	0.4	44.0	6.0	D
Total		3,879	3,845	99.1%	0.6	39.3	2.0	D

VISSIM Post-Processor
Average Results from 10 Runs
Volume and Delay by Movement

Caltrain Electrification
Existing Conditions
PM Peak Hour

Intersection 59

Alma Street/Ravenswood Ave

Side-street Stop

Direction	Movement	Volume (vph)		Percent Served	GEH	Total Delay (sec/veh)		
		Demand	Served			Average	Std. Dev.	LOS
NB	Left Turn	25	27	106.4%	0.3	26.5	11.4	D
	Through	7	6	82.9%	0.5	14.5	15.0	B
	Right Turn	72	71	99.2%	0.1	13.0	5.4	B
	Subtotal	104	104	99.8%	0.0	16.4	5.8	C
SB	Left Turn	3	3	106.7%	0.1	13.0	16.4	B
	Through	4	4	97.5%	0.1	13.5	14.5	B
	Right Turn	47	45	95.3%	0.3	15.2	6.7	C
	Subtotal	54	52	96.1%	0.3	15.2	5.2	C
EB	Left Turn	13	12	93.8%	0.2	16.3	16.8	C
	Through	812	791	97.4%	0.8	15.4	4.7	C
	Right Turn	312	299	95.7%	0.8	21.4	4.8	C
	Subtotal	1,137	1,101	96.9%	1.1	17.1	3.3	C
WB	Left Turn	18	17	95.0%	0.2	13.8	12.5	B
	Through	698	698	99.9%	0.0	12.8	3.7	B
	Right Turn	29	27	94.5%	0.3	13.3	9.4	B
	Subtotal	745	742	99.6%	0.1	12.7	3.6	B
Total		2,040	1,999	98.0%	0.9	15.3	2.0	C

Intersection 60

El Camino Real/Ravenswood Ave

Signal

Direction	Movement	Volume (vph)		Percent Served	GEH	Total Delay (sec/veh)		
		Demand	Served			Average	Std. Dev.	LOS
NB	Left Turn	149	148	99.5%	0.1	182.5	36.4	F
	Through	1,386	1,336	96.4%	1.4	172.0	38.6	F
	Right Turn	626	592	94.6%	1.4	262.9	55.9	F
	Subtotal	2,161	2,077	96.1%	1.8	199.3	22.7	F
SB	Left Turn	162	167	103.0%	0.4	79.0	9.2	E
	Through	998	995	99.7%	0.1	43.3	7.2	D
	Right Turn	48	48	100.8%	0.1	90.5	35.8	F
	Subtotal	1,208	1,211	100.2%	0.1	50.7	6.9	D
EB	Left Turn	37	37	99.2%	0.0	58.3	7.9	E
	Through	237	234	98.9%	0.2	59.2	5.9	E
	Right Turn	105	104	98.9%	0.1	48.1	10.7	D
	Subtotal	379	375	98.9%	0.2	56.2	4.1	E
WB	Left Turn	427	424	99.3%	0.2	47.8	5.5	D
	Through	256	251	98.0%	0.3	51.7	6.0	D
	Right Turn	80	84	104.6%	0.4	11.7	5.7	B
	Subtotal	763	758	99.4%	0.2	45.3	4.9	D
Total		4,511	4,420	98.0%	1.4	119.0	10.4	F

Intersection 63 Meadow Drive/Alma Street Signal

Direction	Movement	Volume (vph)		Percent Served	Total Delay (sec/veh)			
		Demand	Served		GEH	Average	Std. Dev.	LOS
NB	Left Turn	112	108	96.8%	0.3	93.2	14.2	F
	Through	1,395	1,419	101.7%	0.6	47.4	11.2	D
	Right Turn	59	61	103.6%	0.3	46.6	15.9	D
	Subtotal	1,566	1,589	101.5%	0.6	50.7	11.4	D
SB	Left Turn	53	53	99.4%	0.0	101.1	12.2	F
	Through	670	671	100.2%	0.0	24.8	2.7	C
	Right Turn	139	141	101.1%	0.1	9.1	2.9	A
	Subtotal	862	864	100.3%	0.1	27.4	3.0	C
EB	Left Turn	163	156	95.9%	0.5	136.1	7.6	F
	Through	172	169	98.0%	0.3	133.6	8.4	F
	Right Turn	95	91	95.6%	0.4	123.5	12.1	F
	Subtotal	430	416	96.7%	0.7	132.3	6.6	F
WB	Left Turn	120	118	98.3%	0.2	197.0	15.6	F
	Through	214	203	95.0%	0.7	203.4	12.2	F
	Right Turn	83	81	97.1%	0.3	171.4	10.7	F
	Subtotal	417	402	96.4%	0.7	194.9	11.4	F
Total		3,275	3,271	99.9%	0.1	72.6	5.8	E

Intersection 68 Alma Street/Charleston Road Signal

Direction	Movement	Volume (vph)		Percent Served	Total Delay (sec/veh)			
		Demand	Served		GEH	Average	Std. Dev.	LOS
NB	Left Turn	223	211	94.6%	0.8	150.2	16.7	F
	Through	1,365	1,350	98.9%	0.4	44.4	7.5	D
	Right Turn	43	45	104.2%	0.3	40.3	11.8	D
	Subtotal	1,631	1,605	98.4%	0.6	57.1	8.0	E
SB	Left Turn	73	67	92.3%	0.7	151.4	55.7	F
	Through	775	752	97.0%	0.8	30.1	4.1	C
	Right Turn	70	70	100.4%	0.0	14.4	4.5	B
	Subtotal	918	890	96.9%	0.9	37.5	7.5	D
EB	Left Turn	120	118	98.4%	0.2	70.6	10.6	E
	Through	423	416	98.4%	0.3	69.2	4.4	E
	Right Turn	127	125	98.7%	0.1	63.3	4.3	E
	Subtotal	670	660	98.5%	0.4	68.3	4.6	E
WB	Left Turn	70	72	102.7%	0.2	135.5	24.6	F
	Through	274	279	101.8%	0.3	131.1	21.0	F
	Right Turn	101	108	107.1%	0.7	120.0	34.4	F
	Subtotal	445	459	103.1%	0.7	129.6	22.8	F
Total		3,664	3,614	98.6%	0.8	63.5	4.5	E

Intersection 67 Meadow Drive/Park Ave Side-street Stop

Direction	Movement	Volume (vph)		Percent Served	Total Delay (sec/veh)			
		Demand	Served		GEH	Average	Std. Dev.	LOS
NB	Left Turn	9	7	82.2%	0.6	223.0	320.7	F
	Through							
	Right Turn	30	27	90.0%	0.6	383.2	314.0	F
	Subtotal	39	34	88.2%	0.8	332.6	278.2	F
SB	Left Turn							
	Through							
	Right Turn	5	4	82.0%	0.4	5.8	3.0	A
	Subtotal	5	4	82.0%	0.4	5.8	3.0	A
EB	Left Turn							
	Through	400	394	98.4%	0.3	66.1	31.7	F
	Right Turn	4	5	120.0%	0.4	37.3	50.1	E
	Subtotal	404	398	98.6%	0.3	65.8	31.6	F
WB	Left Turn							
	Through	380	368	96.8%	0.6	0.9	0.4	A
	Right Turn	85	84	99.2%	0.1	1.4	0.6	A
	Subtotal	465	452	97.2%	0.6	1.0	0.4	A
Total		913	889	97.4%	0.8	40.4	21.0	E

Intersection 63 Meadow Drive/Alma Street Signal

Direction	Movement	Volume (vph)		Percent Served	Total Delay (sec/veh)			
		Demand	Served		GEH	Average	Std. Dev.	LOS
NB	Left Turn	66	66	100.5%	0.0	85.0	14.8	F
	Through	1,138	1,142	100.4%	0.1	35.7	3.0	D
	Right Turn	76	82	108.0%	0.7	35.0	6.4	C
	Subtotal	1,280	1,291	100.8%	0.3	38.2	3.2	D
SB	Left Turn	67	69	103.4%	0.3	151.9	35.5	F
	Through	1,266	1,269	100.2%	0.1	42.8	21.7	D
	Right Turn	135	134	99.5%	0.1	28.9	20.1	C
	Subtotal	1,468	1,472	100.3%	0.1	48.1	22.4	D
EB	Left Turn	120	116	96.5%	0.4	77.0	7.7	E
	Through	195	192	98.3%	0.2	74.0	9.9	E
	Right Turn	70	69	99.0%	0.1	62.9	6.9	E
	Subtotal	385	377	97.9%	0.4	72.9	7.2	E
WB	Left Turn	74	66	89.3%	0.9	195.9	28.3	F
	Through	233	236	101.3%	0.2	190.2	35.6	F
	Right Turn	79	78	99.0%	0.1	162.7	46.0	F
	Subtotal	386	380	98.5%	0.3	185.4	36.3	F
Total		3,519	3,520	100.0%	0.0	62.0	11.4	E

Intersection 68 Charleston Road/Alma Street Signal

Direction	Movement	Volume (vph)		Percent Served	Total Delay (sec/veh)			
		Demand	Served		GEH	Average	Std. Dev.	LOS
NB	Left Turn	184	178	96.9%	0.4	139.9	17.9	F
	Through	1,084	1,069	98.6%	0.5	36.8	3.0	D
	Right Turn	77	75	97.5%	0.2	35.5	7.4	D
	Subtotal	1,345	1,322	98.3%	0.6	53.0	5.0	D
SB	Left Turn	104	88	84.1%	1.7	311.8	51.8	F
	Through	1,260	1,193	94.7%	1.9	86.2	17.9	F
	Right Turn	96	99	102.7%	0.3	55.5	13.0	E
	Subtotal	1,460	1,379	94.5%	2.1	100.7	18.8	F
EB	Left Turn	89	84	94.5%	0.5	53.8	7.9	D
	Through	381	376	98.7%	0.3	55.7	2.0	E
	Right Turn	202	197	97.7%	0.3	49.7	3.9	D
	Subtotal	672	657	97.8%	0.6	53.7	1.2	D
WB	Left Turn	54	56	103.5%	0.3	123.7	26.1	F
	Through	401	404	100.7%	0.1	126.7	26.6	F
	Right Turn	107	112	104.8%	0.5	123.7	34.2	F
	Subtotal	562	572	101.8%	0.4	126.0	26.2	F
Total		4,039	3,931	97.3%	1.7	80.5	9.6	F

Intersection 67 Meadow Drive/Park Ave Side-street Stop

Direction	Movement	Volume (vph)		Percent Served	Total Delay (sec/veh)			
		Demand	Served		GEH	Average	Std. Dev.	LOS
NB	Left Turn	2	2	100.0%	0.0	8.2	11.2	A
	Through							
	Right Turn	21	18	85.7%	0.7	33.3	20.3	D
	Subtotal	23	20	87.0%	0.6	29.3	16.2	D
SB	Left Turn							
	Through							
	Right Turn	20	17	85.5%	0.7	5.9	1.0	A
	Subtotal	20	17	85.5%	0.7	5.9	1.0	A
EB	Left Turn							
	Through	364	362	99.4%	0.1	16.2	9.5	C
	Right Turn	18	15	85.0%	0.7	14.9	17.0	B
	Subtotal	382	377	98.7%	0.3	16.2	9.6	C
WB	Left Turn							
	Through	347	350	100.9%	0.2	1.2	0.4	A
	Right Turn	87	86	98.7%	0.1	1.8	0.6	A
	Subtotal	434	436	100.4%	0.1	1.4	0.4	A
Total		859	850	99.0%	0.3	8.9	4.5	A

VISSIM Post-Processor
Average Results from 10 Runs
Volume and Delay by Movement

Caltrain Electrification
Existing Conditions
AM Peak Hour

Intersection 66

Alma Street/Churchill Street

Signal

Direction	Movement	Volume (vph)		Percent Served	GEH	Total Delay (sec/veh)		
		Demand	Served			Average	Std. Dev.	LOS
NB	Left Turn	231	216	93.4%	1.0	253.6	60.0	F
	Through	1,267	1,245	98.2%	0.6	55.3	18.9	E
	Right Turn	20	21	103.5%	0.2	54.9	20.3	D
	Subtotal	1,518	1,481	97.6%	1.0	88.4	23.6	F
SB	Left Turn	5	4	86.0%	0.3	95.7	93.3	F
	Through	620	623	100.4%	0.1	34.9	3.9	C
	Right Turn	193	190	98.2%	0.3	17.7	4.0	B
	Subtotal	818	817	99.8%	0.1	31.6	3.9	C
EB	Left Turn	55	54	97.3%	0.2	47.1	3.2	D
	Through	140	139	99.6%	0.1	44.6	9.0	D
	Right Turn	98	99	100.5%	0.1	14.2	2.9	B
	Subtotal	293	291	99.5%	0.1	35.4	5.2	D
WB	Left Turn	95	93	98.2%	0.2	73.3	22.5	E
	Through	49	46	94.1%	0.4	88.3	14.7	F
	Right Turn	5	5	92.0%	0.2	67.0	79.3	E
	Subtotal	149	144	96.6%	0.4	80.5	17.1	F
Total		2,778	2,733	98.4%	0.9	66.0	12.5	E

VISSIM Post-Processor
Average Results from 10 Runs
Volume and Delay by Movement

Caltrain Electrification
Existing Conditions
PM Peak Hour

Intersection 66

Alma Street/Churchill Street

Signal

Direction	Movement	Volume (vph)		Percent Served	GEH	Total Delay (sec/veh)		
		Demand	Served			Average	Std. Dev.	LOS
NB	Left Turn	154	148	96.2%	0.5	109.2	14.9	F
	Through	783	789	100.7%	0.2	25.9	3.2	C
	Right Turn	49	46	93.5%	0.5	39.4	9.4	D
	Subtotal	986	983	99.7%	0.1	40.2	4.0	D
SB	Left Turn	21	23	107.1%	0.3	159.6	22.2	F
	Through	1,290	1,289	99.9%	0.0	55.7	6.4	E
	Right Turn	120	119	98.9%	0.1	43.4	8.9	D
	Subtotal	1,431	1,430	99.9%	0.0	56.5	6.6	E
EB	Left Turn	124	123	99.0%	0.1	105.5	31.0	F
	Through	167	159	94.9%	0.7	103.9	23.6	F
	Right Turn	256	255	99.5%	0.1	76.0	21.3	E
	Subtotal	547	536	98.0%	0.5	91.2	22.9	F
WB	Left Turn	108	110	101.4%	0.1	149.1	51.2	F
	Through	108	105	97.4%	0.3	155.0	47.4	F
	Right Turn	18	17	92.8%	0.3	138.4	45.1	F
	Subtotal	234	231	98.9%	0.2	151.4	48.0	F
Total		3,198	3,180	99.4%	0.3	64.0	6.6	E

VISSIM Post-Processor
Average Results from 10 Runs
Volume and Delay by Movement

Caltrain Electrification
Existing Conditions
AM Peak Hour

Intersection 70

Rengstorff/Central Expressway

Signal

Direction	Movement	Volume (vph)		Percent Served	Total Delay (sec/veh)		
		Demand	Served		Average	Std. Dev.	LOS
NB	Left Turn	178	179	100.6%	87.2	20.9	F
	Through	489	487	99.6%	105.3	21.8	F
	Right Turn	92	98	106.1%	109.4	30.8	F
	Subtotal	759	764	100.6%	101.7	22.4	F
SB	Left Turn	51	49	95.9%	110.5	30.6	F
	Through	246	250	101.7%	118.5	13.1	F
	Right Turn	69	68	99.0%	100.8	28.5	F
	Subtotal	366	367	100.4%	114.9	10.7	F
EB	Left Turn	97	92	95.2%	94.4	15.2	F
	Through	713	725	101.6%	35.6	4.7	D
	Right Turn	113	110	97.7%	23.9	3.5	C
	Subtotal	923	927	100.5%	40.3	5.4	D
WB	Left Turn	130	126	97.2%	266.7	57.8	F
	Through	1,349	1,344	99.6%	142.8	53.9	F
	Right Turn	248	255	102.8%	80.0	45.7	E
	Subtotal	1,727	1,725	99.9%	143.9	54.0	F
Total		3,775	3,784	100.2%	108.0	27.0	F

Intersection 71

Moffett/Central Expressway

Signal

Direction	Movement	Volume (vph)		Percent Served	Total Delay (sec/veh)		
		Demand	Served		Average	Std. Dev.	LOS
NB	Left Turn	193	190	98.4%	53.3	5.5	D
	Through	247	282	114.1%	60.4	6.6	E
	Right Turn	89	92	103.1%	50.1	12.2	D
	Subtotal	529	564	106.5%	56.4	4.7	E
SB	Left Turn	38	39	103.7%	62.7	16.3	E
	Through	133	133	99.8%	64.8	6.9	E
	Right Turn	174	185	106.4%	43.0	10.8	D
	Subtotal	345	357	103.6%	53.2	7.3	D
EB	Left Turn	118	116	97.9%	89.8	14.8	F
	Through	817	832	101.8%	50.4	5.7	D
	Right Turn	149	144	96.4%	5.5	1.7	A
	Subtotal	1,084	1,091	100.7%	49.0	4.1	D
WB	Left Turn	128	124	96.6%	199.8	57.8	F
	Through	1,363	1,334	97.9%	150.6	61.4	F
	Right Turn	148	137	92.8%	139.3	65.3	F
	Subtotal	1,639	1,595	97.3%	153.7	60.6	F
Total		3,597	3,607	100.3%	100.2	12.4	F

VISSIM Post-Processor
Average Results from 10 Runs
Volume and Delay by Movement

Caltrain Electrification
Existing Conditions
PM Peak Hour

Intersection 70

Rengstorff/Central Expressway

Signal

Direction	Movement	Volume (vph)		Percent Served	Total Delay (sec/veh)		
		Demand	Served		Average	Std. Dev.	LOS
NB	Left Turn	91	90	99.3%	56.3	8.2	E
	Through	309	304	98.5%	59.4	9.0	E
	Right Turn	122	124	101.8%	57.9	7.0	E
	Subtotal	522	519	99.4%	58.4	5.9	E
SB	Left Turn	144	138	96.0%	129.7	15.5	F
	Through	484	493	101.8%	134.2	18.7	F
	Right Turn	46	44	96.5%	113.0	22.4	F
	Subtotal	674	675	100.2%	131.7	16.6	F
EB	Left Turn	92	94	102.6%	165.4	21.6	F
	Through	1,249	1,247	99.8%	82.6	20.2	F
	Right Turn	128	123	95.9%	70.3	20.3	E
	Subtotal	1,469	1,464	99.6%	87.3	19.9	F
WB	Left Turn	157	161	102.2%	186.2	30.0	F
	Through	941	939	99.7%	51.5	4.3	D
	Right Turn	124	127	102.7%	3.0	0.8	A
	Subtotal	1,222	1,226	100.4%	64.8	7.1	E
Total		3,887	3,885	99.9%	85.0	6.4	F

Intersection 71

Moffett/Central Expressway

Signal

Direction	Movement	Volume (vph)		Percent Served	Total Delay (sec/veh)		
		Demand	Served		Average	Std. Dev.	LOS
NB	Left Turn	138	133	96.7%	95.6	23.6	F
	Through	214	217	101.3%	97.9	23.7	F
	Right Turn	143	140	97.9%	96.9	30.9	F
	Subtotal	495	490	99.0%	96.3	22.9	F
SB	Left Turn	41	39	95.9%	88.9	19.8	F
	Through	248	249	100.2%	100.3	12.5	F
	Right Turn	83	80	96.9%	92.3	16.9	F
	Subtotal	372	368	99.0%	97.5	11.1	F
EB	Left Turn	101	98	97.2%	155.9	37.6	F
	Through	1,361	1,377	101.1%	95.2	24.2	F
	Right Turn	189	195	103.2%	68.9	26.6	E
	Subtotal	1,651	1,670	101.1%	95.5	25.2	F
WB	Left Turn	192	196	102.1%	102.3	32.2	F
	Through	1,078	1,118	103.7%	52.2	18.5	D
	Right Turn	77	76	99.2%	42.9	14.9	D
	Subtotal	1,347	1,390	103.2%	59.4	20.2	E
Total		3,865	3,919	101.4%	83.0	7.3	F

VISSIM Post-Processor
Average Results from 10 Runs
Volume and Delay by Movement

Caltrain Electrification
Existing Conditions
AM Peak Hour

Intersection 77

Mary/Evelyn

Signal

Direction	Movement	Volume (vph)		Percent Served	Total Delay (sec/veh)		
		Demand	Served		Average	Std. Dev.	LOS
NB	Left Turn	72	75	104.0%	75.3	15.4	E
	Through	1,036	1,039	100.3%	71.6	13.0	E
	Right Turn	31	32	104.2%	63.8	20.5	E
	Subtotal	1,139	1,146	100.6%	71.6	13.1	E
SB	Left Turn	60	59	97.7%	80.8	14.9	F
	Through	404	410	101.5%	52.3	11.4	D
	Right Turn	183	175	95.4%	51.9	8.5	D
	Subtotal	647	643	99.4%	54.7	9.1	D
EB	Left Turn	193	199	103.1%	113.1	20.8	F
	Through	134	134	100.1%	33.1	7.5	C
	Right Turn	35	36	102.0%	14.5	6.1	B
	Subtotal	362	369	101.9%	77.8	15.1	E
WB	Left Turn	71	71	100.1%	49.5	6.4	D
	Through	267	266	99.7%	40.5	3.5	D
	Right Turn	212	212	100.0%	33.5	6.6	C
	Subtotal	550	549	99.9%	39.2	3.4	D
Total		2,698	2,708	100.4%	62.4	6.1	E

VISSIM Post-Processor
Average Results from 10 Runs
Volume and Delay by Movement

Catrain Electrification
Existing Conditions
PM Peak Hour

Intersection 75

Mary/Evelyn

Signal

Direction	Movement	Volume (vph)		Percent Served	Total Delay (sec/veh)		
		Demand	Served		Average	Std. Dev.	LOS
NB	Left Turn	36	37	103.6%	51.6	11.7	D
	Through	388	386	99.4%	42.2	9.9	D
	Right Turn	31	28	89.0%	19.7	8.2	B
	Subtotal	455	451	99.0%	41.4	9.2	D
SB	Left Turn	157	153	97.5%	91.2	12.4	F
	Through	1,315	1,319	100.3%	73.1	16.2	E
	Right Turn	293	290	99.0%	84.6	17.9	F
	Subtotal	1,765	1,763	99.9%	76.5	15.3	E
EB	Left Turn	225	222	98.8%	66.5	8.0	E
	Through	314	324	103.2%	34.5	4.6	C
	Right Turn	86	90	105.1%	19.7	4.3	B
	Subtotal	625	637	101.9%	44.1	3.6	D
WB	Left Turn	59	58	98.3%	52.1	9.0	D
	Through	186	187	100.8%	44.0	8.9	D
	Right Turn	94	92	97.4%	25.3	9.4	C
	Subtotal	339	337	99.4%	39.9	8.6	D
Total		3,184	3,187	100.1%	61.5	9.6	E

2020 No Project



Intersection 1

4th Street/King Street

Signal

Direction	Movement	Volume (vph)		Percent Served	GEH	Total Delay (sec/veh)		
		Demand	Served			Average	Std. Dev.	LOS
NB	Left Turn	10	10	96.0%	0.1	81.0	27.5	F
	Through	60	78	129.5%	2.1	31.1	7.3	C
	Right Turn	40	39	98.0%	0.1	12.2	5.8	B
	Subtotal	110	127	115.0%	1.5	29.6	5.5	C
SB	Left Turn	130	135	104.1%	0.5	84.8	15.1	F
	Through	440	419	95.2%	1.0	53.1	6.4	D
	Right Turn	260	243	93.4%	1.1	39.3	6.8	D
	Subtotal	830	797	96.0%	1.2	54.5	5.2	D
EB	Left Turn	90	78	87.1%	1.3	391.1	29.2	F
	Through	1,570	1,404	89.4%	4.3	200.1	9.5	F
	Right Turn	10	9	93.0%	0.2	98.6	44.7	F
	Subtotal	1,670	1,492	89.3%	4.5	210.0	9.2	F
WB	Left Turn	40	50	123.8%	1.4	81.7	15.9	F
	Through	750	752	100.3%	0.1	45.4	4.4	D
	Right Turn	30	47	156.7%	2.7	32.5	10.4	C
	Subtotal	820	848	103.5%	1.0	46.8	3.8	D
Total		3,430	3,264	95.1%	2.9	122.8	4.5	F

Intersection 2

4th Street/Townsend Street

Signal

Direction	Movement	Volume (vph)		Percent Served	GEH	Total Delay (sec/veh)		
		Demand	Served			Average	Std. Dev.	LOS
NB	Left Turn							
	Through	30	25	81.7%	1.1	38.7	13.4	D
	Right Turn	150	168	111.8%	1.4	25.9	5.7	C
	Subtotal	180	192	106.8%	0.9	27.4	6.3	C
SB	Left Turn							
	Through	470	553	117.6%	3.7	118.2	47.9	F
	Right Turn	80	75	94.3%	0.5	202.9	66.1	F
	Subtotal	550	628	114.2%	3.2	129.1	49.0	F
EB	Left Turn							
	Through	410	355	86.5%	2.8	354.7	82.1	F
	Right Turn	180	132	73.2%	3.9	714.4	176.5	F
	Subtotal	590	486	82.4%	4.5	461.1	106.4	F
WB	Left Turn	180	178	99.1%	0.1	90.1	41.8	F
	Through	220	227	103.0%	0.4	12.2	4.1	B
	Right Turn							
	Subtotal	400	405	101.2%	0.2	49.0	23.7	D
Total		1,720	1,712	99.5%	0.2	179.8	29.7	F

Intersection 1

4th Street/King Street

Signal

Direction	Movement	Volume (vph)		Percent Served	GEH	Total Delay (sec/veh)		
		Demand	Served			Average	Std. Dev.	LOS
NB	Left Turn	20	20	100.0%	0.0	54.5	14.9	D
	Through	70	115	164.7%	4.7	28.5	13.6	C
	Right Turn	50	60	119.2%	1.3	16.9	6.8	B
	Subtotal	140	195	139.2%	4.2	27.6	9.6	C
SB	Left Turn	150	120	79.8%	2.6	81.5	19.6	F
	Through	340	291	85.5%	2.8	58.0	4.7	E
	Right Turn	600	468	78.1%	5.7	46.5	2.9	D
	Subtotal	1,090	879	80.6%	6.7	54.7	3.5	D
EB	Left Turn	140	112	80.3%	2.5	401.0	39.0	F
	Through	1,430	1,204	84.2%	6.2	235.9	27.6	F
	Right Turn	20	18	87.5%	0.6	111.8	27.3	F
	Subtotal	1,590	1,333	83.9%	6.7	248.9	28.9	F
WB	Left Turn	30	26	85.0%	0.9	294.3	25.6	F
	Through	1,000	917	91.7%	2.7	291.4	19.0	F
	Right Turn	20	49	246.5%	5.0	115.9	68.4	F
	Subtotal	1,050	992	94.5%	1.8	283.6	18.6	F
Total		3,870	3,399	87.8%	7.8	195.2	12.4	F

195.2

Intersection 2

4th Street/Townsend Street

Signal

Direction	Movement	Volume (vph)		Percent Served	GEH	Total Delay (sec/veh)		
		Demand	Served			Average	Std. Dev.	LOS
NB	Left Turn							
	Through	20	15	75.0%	1.2	35.1	15.6	D
	Right Turn	210	213	101.3%	0.2	36.4	15.6	D
	Subtotal	230	228	99.0%	0.2	36.2	15.1	D
SB	Left Turn							
	Through	670	556	82.9%	4.6	339.5	27.3	F
	Right Turn	90	63	70.0%	3.1	613.2	68.1	F
	Subtotal	760	619	81.4%	5.4	371.7	29.2	F
EB	Left Turn							
	Through	290	325	111.9%	2.0	34.7	6.5	C
	Right Turn	130	132	101.5%	0.2	72.3	25.5	E
	Subtotal	420	456	108.7%	1.7	46.3	10.7	D
WB	Left Turn	290	261	89.9%	1.8	264.4	99.1	F
	Through	310	310	100.0%	0.0	80.9	48.4	F
	Right Turn							
	Subtotal	600	571	95.2%	1.2	167.7	69.3	F
Total		2,010	1,874	93.2%	3.1	191.6	20.3	F

VISSIM Post-Processor
Average Results from 10 Runs
Volume and Delay by Movement

Caltrain Electrification
2020 No Project
AM Peak Hour

Intersection 18

California/Broadway

Signal

Direction	Movement	Volume (vph)		Percent Served	Total Delay (sec/veh)		
		Demand	Served		Average	Std. Dev.	LOS
NB	Left Turn	30	29	95.3%	84.7	24.7	F
	Through	280	282	100.8%	61.5	9.1	E
	Right Turn	540	539	99.8%	25.3	6.4	C
	Subtotal	850	850	100.0%	38.6	6.4	D
SB	Left Turn	440	388	88.3%	144.2	12.8	F
	Through	410	370	90.2%	129.5	7.9	F
	Right Turn	30	28	94.0%	123.7	25.8	F
	Subtotal	880	787	89.4%	136.6	10.5	F
EB	Left Turn	10	9	93.0%	84.5	50.4	F
	Through	380	377	99.2%	91.6	24.3	F
	Right Turn	40	41	102.3%	73.7	24.7	E
	Subtotal	430	427	99.4%	90.1	23.8	F
WB	Left Turn	260	256	98.6%	16.8	2.3	B
	Through	350	355	101.3%	7.2	1.1	A
	Right Turn	260	262	100.9%	1.1	1.0	A
	Subtotal	870	873	100.4%	8.2	0.8	A
Total		3,030	2,937	96.9%	61.3	4.6	E

Intersection 19

Carolan/Broadway

Signal

Direction	Movement	Volume (vph)		Percent Served	Total Delay (sec/veh)		
		Demand	Served		Average	Std. Dev.	LOS
NB	Left Turn	100	103	102.7%	102.6	14.2	F
	Through	1	9	910.0%	82.3	55.3	F
	Right Turn	400	395	98.8%	19.6	4.8	B
	Subtotal	501	507	101.2%	38.3	5.3	D
SB	Left Turn						
	Through						
	Right Turn						
	Subtotal						
EB	Left Turn	10	9	94.0%	20.7	20.1	C
	Through	1,170	1,117	95.5%	1.7	0.3	A
	Right Turn	180	177	98.6%	2.0	1.1	A
	Subtotal	1,360	1,304	95.9%	1.9	0.5	A
WB	Left Turn	160	157	98.3%	81.5	12.5	F
	Through	770	771	100.2%	27.7	8.2	C
	Right Turn	10	8	76.0%	4.2	4.1	A
	Subtotal	940	936	99.6%	36.2	6.8	D
Total		2,801	2,747	98.1%	20.7	3.0	C

Intersection 5

7th Street/16th Street

Signal

Direction	Movement	Volume (vph)		Percent Served	GEH	Total Delay (sec/veh)		
		Demand	Served			Average	Std. Dev.	LOS
NB	Left Turn	190	192	101.1%	0.1	127.6	28.0	F
	Through	390	367	94.0%	1.2	125.7	30.7	F
	Right Turn	110	104	94.3%	0.6	100.6	28.3	F
	Subtotal	690	662	96.0%	1.1	122.8	29.5	F
SB	Left Turn	120	120	99.7%	0.0	132.1	27.3	F
	Through	100	100	99.7%	0.0	96.2	37.6	F
	Right Turn	40	40	100.0%	0.0	58.9	35.6	E
	Subtotal	260	259	99.7%	0.0	105.9	27.1	F
EB	Left Turn	40	42	106.0%	0.4	94.3	21.9	F
	Through	380	387	101.9%	0.4	82.3	15.7	F
	Right Turn	120	116	96.7%	0.4	70.8	19.5	E
	Subtotal	540	546	101.0%	0.2	80.7	15.1	F
WB	Left Turn	70	66	93.9%	0.5	90.6	37.4	F
	Through	220	217	98.5%	0.2	57.8	17.8	E
	Right Turn	170	171	100.5%	0.1	27.9	7.2	C
	Subtotal	460	453	98.5%	0.3	50.3	13.8	D
Total		1,950	1,920	98.5%	0.7	90.9	10.4	F

Intersection 6

Owens Street/16th Street

Signal

Direction	Movement	Volume (vph)		Percent Served	GEH	Total Delay (sec/veh)		
		Demand	Served			Average	Std. Dev.	LOS
NB	Left Turn							
	Through							
	Right Turn							
	Subtotal							
SB	Left Turn	60	59	97.8%	0.2	17.1	3.1	B
	Through							
	Right Turn	110	111	100.7%	0.1	6.0	0.7	A
	Subtotal	170	170	99.7%	0.0	9.9	1.4	A
EB	Left Turn	250	253	101.1%	0.2	22.3	7.3	C
	Through	360	358	99.4%	0.1	3.7	1.3	A
	Right Turn							
	Subtotal	610	611	100.1%	0.0	11.5	3.8	B
WB	Left Turn							
	Through	350	344	98.2%	0.3	12.3	2.1	B
	Right Turn	120	123	102.8%	0.3	9.7	2.3	A
	Subtotal	470	467	99.4%	0.1	11.6	1.9	B
Total		1,250	1,247	99.8%	0.1	11.3	1.9	B

Intersection 5

7th Street/16th Street

Signal

Direction	Movement	Volume (vph)		Percent Served	GEH	Total Delay (sec/veh)		
		Demand	Served			Average	Std. Dev.	LOS
NB	Left Turn	230	227	98.7%	0.2	81.4	15.1	F
	Through	350	346	98.8%	0.2	80.8	15.9	F
	Right Turn	50	46	92.0%	0.6	55.9	24.4	E
	Subtotal	630	619	98.2%	0.4	79.1	15.7	E
SB	Left Turn	80	85	105.6%	0.5	101.6	20.2	F
	Through	140	139	99.3%	0.1	97.3	28.4	F
	Right Turn	40	37	92.5%	0.5	83.8	26.2	F
	Subtotal	260	261	100.2%	0.0	97.6	23.3	F
EB	Left Turn	50	46	92.6%	0.5	136.2	35.1	F
	Through	430	420	97.6%	0.5	92.0	13.7	F
	Right Turn	80	82	102.0%	0.2	71.6	17.9	E
	Subtotal	560	548	97.8%	0.5	92.7	14.9	F
WB	Left Turn	100	96	95.5%	0.5	67.7	16.1	E
	Through	480	480	100.0%	0.0	33.4	6.5	C
	Right Turn	300	304	101.2%	0.2	32.1	7.1	C
	Subtotal	880	879	99.9%	0.0	36.8	6.6	D
Total		2,330	2,306	99.0%	0.5	67.7	4.9	E

Intersection 6

Owens Street/16th Street

Signal

Direction	Movement	Volume (vph)		Percent Served	GEH	Total Delay (sec/veh)		
		Demand	Served			Average	Std. Dev.	LOS
NB	Left Turn							
	Through							
	Right Turn							
	Subtotal							
SB	Left Turn	160	161	100.8%	0.1	17.9	2.8	B
	Through							
	Right Turn	190	186	98.1%	0.3	9.3	0.7	A
	Subtotal	350	348	99.3%	0.1	13.5	1.2	B
EB	Left Turn	110	110	100.3%	0.0	22.2	3.2	C
	Through	440	437	99.3%	0.1	5.7	1.6	A
	Right Turn							
	Subtotal	550	547	99.5%	0.1	9.0	1.7	A
WB	Left Turn							
	Through	690	693	100.5%	0.1	16.5	2.4	B
	Right Turn	90	85	94.1%	0.6	14.8	3.3	B
	Subtotal	780	778	99.7%	0.1	16.3	2.4	B
Total		1,680	1,673	99.6%	0.2	13.4	1.0	B

VISSIM Post-Processor
Average Results from 10 Runs
Volume and Delay by Movement

Caltrain Electrification
2020 No Project
PM Peak Hour

Intersection 18

California/Broadway

Signal

Direction	Movement	Volume (vph)		Percent Served	Total Delay (sec/veh)		
		Demand	Served		Average	Std. Dev.	LOS
NB	Left Turn	40	40	100.5%	64.6	9.9	E
	Through	370	361	97.6%	61.4	7.2	E
	Right Turn	350	357	102.0%	16.3	5.5	B
	Subtotal	760	758	99.8%	40.3	3.9	D
SB	Left Turn	480	363	75.6%	146.1	15.1	F
	Through	400	303	75.9%	149.9	16.5	F
	Right Turn	60	44	72.5%	125.2	13.8	F
	Subtotal	940	710	75.5%	146.0	13.2	F
EB	Left Turn	20	20	102.0%	94.8	51.4	F
	Through	300	299	99.6%	73.2	28.9	E
	Right Turn	50	49	97.6%	62.1	35.1	E
	Subtotal	370	368	99.4%	73.7	30.8	E
WB	Left Turn	360	340	94.4%	16.1	1.4	B
	Through	490	467	95.4%	7.1	1.0	A
	Right Turn	430	423	98.3%	2.4	0.7	A
	Subtotal	1,280	1,230	96.1%	7.8	0.7	A
Total		3,350	3,066	91.5%	58.0	3.6	E

Intersection 19

Carolan/Broadway

Signal

Direction	Movement	Volume (vph)		Percent Served	Total Delay (sec/veh)		
		Demand	Served		Average	Std. Dev.	LOS
NB	Left Turn	170	168	99.1%	229.1	71.2	F
	Through	10	9	92.0%	285.5	74.8	F
	Right Turn	350	353	100.9%	72.2	52.9	E
	Subtotal	530	531	100.1%	132.5	54.1	F
SB	Left Turn						
	Through						
	Right Turn						
	Subtotal						
EB	Left Turn	10	10	100.0%	50.4	36.2	D
	Through	1,010	908	89.9%	3.8	0.5	A
	Right Turn	110	101	91.7%	2.1	1.8	A
	Subtotal	1,130	1,019	90.2%	4.1	0.6	A
WB	Left Turn	300	286	95.4%	126.2	23.4	F
	Through	1,110	1,063	95.7%	22.0	11.4	C
	Right Turn	10	9	90.0%	16.6	13.4	B
	Subtotal	1,420	1,358	95.6%	45.9	13.2	D
Total		3,080	2,907	94.4%	48.6	14.4	D

Intersection 45 El Camino Real/Whipple Road Signal

Direction	Movement	Volume (vph)		Percent Served	Total Delay (sec/veh)		
		Demand	Served		Average	Std. Dev.	LOS
NB	Left Turn	60	60	100.0%	59.3	5.1	E
	Through	880	880	100.0%	38.0	7.3	D
	Right Turn	490	490	100.0%	25.0	6.0	C
	Subtotal	1,430	1,430	100.0%	34.7	6.0	C
SB	Left Turn	300	302	100.5%	134.9	29.1	F
	Through	1,050	1,049	99.9%	33.9	4.4	C
	Right Turn	70	71	100.9%	30.8	4.2	C
	Subtotal	1,420	1,422	100.1%	54.9	8.5	D
EB	Left Turn	110	107	97.5%	198.6	30.0	F
	Through	450	429	95.4%	189.4	31.0	F
	Right Turn	50	47	93.4%	172.4	31.4	F
	Subtotal	610	583	95.6%	189.7	30.4	F
WB	Left Turn	290	293	100.9%	32.6	3.2	C
	Through	290	287	99.0%	27.0	2.3	C
	Right Turn	280	278	99.2%	13.5	1.3	B
	Subtotal	860	857	99.7%	25.0	2.3	C
Total		4,320	4,293	99.4%	59.0	5.3	E

Intersection 62 Palo Alto/Alma Side-street Stop

Direction	Movement	Volume (vph)		Percent Served	Total Delay (sec/veh)		
		Demand	Served		Average	Std. Dev.	LOS
NB	Left Turn						
	Through						
	Right Turn						
	Subtotal						
SB	Left Turn	10	9	92.0%	4.8	2.8	A
	Through						
	Right Turn	30	28	94.0%	9.3	5.0	A
	Subtotal	40	37	93.5%	8.4	3.8	A
EB	Left Turn						
	Through	500	501	100.2%	4.1	1.5	A
	Right Turn						
	Subtotal	500	501	100.2%	4.1	1.5	A
WB	Left Turn						
	Through	550	549	99.9%	5.9	1.7	A
	Right Turn	20	20	100.0%	1.6	1.9	A
	Subtotal	570	569	99.9%	5.8	1.7	A
Total		1,110	1,108	99.8%	7.9	1.2	A

Intersection 64 El Camino Real/Sand Hill-Palo Alto Signal

Direction	Movement	Volume (vph)		Percent Served	Total Delay (sec/veh)		
		Demand	Served		Average	Std. Dev.	LOS
NB	Left Turn	140	137	97.9%	71.6	10.1	E
	Through	580	586	101.0%	45.0	4.2	D
	Right Turn	30	29	96.0%	18.1	8.3	B
	Subtotal	750	751	100.2%	49.0	3.1	D
SB	Left Turn	470	473	100.6%	140.1	42.0	F
	Through	1,330	1,333	100.2%	38.3	7.6	D
	Right Turn	650	642	98.7%	109.9	45.7	F
	Subtotal	2,450	2,448	99.9%	77.9	19.7	E
EB	Left Turn	280	283	101.0%	60.6	6.1	E
	Through						
	Right Turn	230	224	97.3%	9.0	1.8	A
	Subtotal	510	507	99.4%	38.9	4.5	D
WB	Left Turn						
	Through						
	Right Turn	580	577	99.6%	3.4	0.8	A
	Subtotal	580	577	99.6%	3.4	0.8	A
Total		4,290	4,283	99.8%	58.5	11.4	E

Intersection 45 El Camino Real/Whipple Road Signal

Direction	Movement	Volume (vph)		Percent Served	Total Delay (sec/veh)		
		Demand	Served		Average	Std. Dev.	LOS
NB	Left Turn	60	60	99.2%	83.3	10.2	F
	Through	1,270	1,284	101.1%	33.1	3.6	C
	Right Turn	300	299	99.6%	22.1	4.0	C
	Subtotal	1,630	1,643	100.8%	33.0	3.4	C
SB	Left Turn	310	297	95.8%	236.4	68.4	F
	Through	1,060	1,071	101.0%	42.5	13.7	D
	Right Turn	100	103	103.0%	42.2	15.1	D
	Subtotal	1,470	1,471	100.1%	82.2	22.7	F
EB	Left Turn	130	125	96.5%	77.2	11.1	E
	Through	250	247	98.6%	74.2	12.2	E
	Right Turn	60	57	95.2%	61.1	13.9	E
	Subtotal	440	429	97.5%	73.7	10.8	E
WB	Left Turn	380	382	100.4%	46.5	5.9	D
	Through	400	392	98.0%	44.2	5.1	D
	Right Turn	320	318	99.3%	16.0	3.2	B
	Subtotal	1,100	1,091	99.2%	36.5	3.5	D
Total		4,640	4,634	99.9%	53.5	2.1	D

Intersection 62 Palo Alto/Alma Side-street Stop

Direction	Movement	Volume (vph)		Percent Served	Total Delay (sec/veh)		
		Demand	Served		Average	Std. Dev.	LOS
NB	Left Turn						
	Through						
	Right Turn						
	Subtotal						
SB	Left Turn	10	9	91.0%	4.6	1.8	A
	Through						
	Right Turn	20	19	95.5%	16.5	6.7	C
	Subtotal	30	28	94.0%	12.4	3.6	B
EB	Left Turn						
	Through	570	563	98.8%	0.9	0.5	A
	Right Turn						
	Subtotal	570	563	98.8%	0.9	0.5	A
WB	Left Turn						
	Through	780	781	100.1%	3.7	0.9	A
	Right Turn	60	58	96.3%	1.8	1.2	A
	Subtotal	840	839	99.8%	3.6	0.9	A
Total		1,440	1,430	99.3%	7.3	0.6	A

Intersection 64 El Camino Real/Sand Hill-Palo Alto Signal

Direction	Movement	Volume (vph)		Percent Served	Total Delay (sec/veh)		
		Demand	Served		Average	Std. Dev.	LOS
NB	Left Turn	150	155	103.0%	58.7	9.3	E
	Through	1,290	1,292	100.2%	53.2	4.9	D
	Right Turn	140	138	98.2%	27.8	4.9	C
	Subtotal	1,580	1,584	100.3%	51.6	4.7	D
SB	Left Turn	430	425	98.9%	175.7	78.4	F
	Through	1,140	1,149	100.8%	36.9	4.9	D
	Right Turn	280	270	96.4%	14.0	1.6	B
	Subtotal	1,850	1,844	99.7%	65.3	20.2	E
EB	Left Turn	790	684	86.6%	95.6	7.6	F
	Through						
	Right Turn	310	266	85.7%	41.1	5.4	D
	Subtotal	1,100	950	86.4%	80.3	7.4	F
WB	Left Turn						
	Through						
	Right Turn	800	802	100.3%	6.2	1.0	A
	Subtotal	800	802	100.3%	6.2	1.0	A
Total		5,330	5,181	97.2%	54.9	8.2	D

Intersection 59

Alma Street/Ravenswood Ave

Side-street Stop

Direction	Movement	Volume (vph)		Percent Served	GEH	Total Delay (sec/veh)		
		Demand	Served			Average	Std. Dev.	LOS
NB	Left Turn	20	19	94.5%	0.2	22.6	9.7	C
	Through	10	9	94.0%	0.2	16.9	14.5	C
	Right Turn	10	9	86.0%	0.5	9.7	4.7	A
	Subtotal	40	37	92.3%	0.5	18.7	8.0	C
SB	Left Turn	10	13	130.0%	0.9	46.3	24.5	E
	Through	10	9	91.0%	0.3	43.6	29.1	E
	Right Turn	40	38	93.8%	0.4	38.1	21.2	E
	Subtotal	60	60	99.3%	0.1	40.6	21.0	E
EB	Left Turn	30	31	103.3%	0.2	35.0	14.6	D
	Through	680	675	99.2%	0.2	24.1	3.4	C
	Right Turn	210	207	98.7%	0.2	31.0	7.7	D
	Subtotal	920	913	99.2%	0.2	26.2	4.1	D
WB	Left Turn	10	10	95.0%	0.2	22.4	19.6	C
	Through	820	833	101.6%	0.4	28.3	14.8	D
	Right Turn	30	29	96.3%	0.2	25.1	28.6	D
	Subtotal	860	871	101.3%	0.4	28.3	15.0	D
Total		1,880	1,881	100.0%	0.0	27.5	8.7	D

Intersection 60

El Camino Real/Ravenswood Ave

Signal

Direction	Movement	Volume (vph)		Percent Served	GEH	Total Delay (sec/veh)		
		Demand	Served			Average	Std. Dev.	LOS
NB	Left Turn	430	104	24.3%	19.9	72.4	12.9	E
	Through	1,110	1,101	99.2%	0.3	48.8	3.5	D
	Right Turn	100	426	426.3%	20.1	21.8	5.3	C
	Subtotal	1,640	1,632	99.5%	0.2	42.8	2.8	D
SB	Left Turn	310	309	99.7%	0.1	158.2	43.5	F
	Through	1,340	1,322	98.7%	0.5	76.0	30.5	E
	Right Turn	30	33	110.7%	0.6	73.4	35.3	E
	Subtotal	1,680	1,665	99.1%	0.4	92.5	33.7	F
EB	Left Turn	20	20	99.5%	0.0	132.2	57.4	F
	Through	390	388	99.5%	0.1	137.0	48.9	F
	Right Turn	60	83	139.0%	2.8	105.2	37.9	F
	Subtotal	470	491	104.6%	1.0	131.7	47.0	F
WB	Left Turn	581	573	98.6%	0.3	65.3	5.5	E
	Through	271	273	100.6%	0.1	68.1	9.0	E
	Right Turn	100	100	99.5%	0.1	21.6	7.3	C
	Subtotal	952	945	99.3%	0.2	62.2	4.5	E
Total		4,742	4,733	99.8%	0.1	73.6	10.2	E

Intersection 59

Alma Street/Ravenswood Ave

Side-street Stop

Direction	Movement	Volume (vph)		Percent Served	GEH	Total Delay (sec/veh)		
		Demand	Served			Average	Std. Dev.	LOS
NB	Left Turn	30	31	102.0%	0.1	28.0	19.9	D
	Through	10	9	88.0%	0.4	33.1	29.0	D
	Right Turn	80	78	98.0%	0.2	16.6	8.2	C
	Subtotal	120	118	98.2%	0.2	21.2	10.1	C
SB	Left Turn	10	11	113.0%	0.4	62.1	26.2	F
	Through	10	9	86.0%	0.5	43.6	36.5	E
	Right Turn	50	49	98.6%	0.1	39.2	21.6	E
	Subtotal	70	69	98.9%	0.1	41.8	20.8	E
EB	Left Turn	20	17	86.5%	0.6	16.1	8.1	C
	Through	820	725	88.4%	3.4	10.8	2.6	B
	Right Turn	320	276	86.2%	2.6	16.8	4.5	C
	Subtotal	1,160	1,018	87.8%	4.3	11.4	2.2	B
WB	Left Turn	20	20	98.0%	0.1	17.4	8.1	C
	Through	820	820	99.9%	0.0	17.6	5.5	C
	Right Turn	30	31	104.3%	0.2	14.8	8.8	B
	Subtotal	870	870	100.0%	0.0	17.5	5.5	C
Total		2,220	2,075	93.5%	3.1	17.1	2.6	C

Intersection 60

El Camino Real/Ravenswood Ave

Signal

Direction	Movement	Volume (vph)		Percent Served	GEH	Total Delay (sec/veh)		
		Demand	Served			Average	Std. Dev.	LOS
NB	Left Turn	180	166	92.1%	1.1	167.9	20.4	F
	Through	1,510	1,356	89.8%	4.1	166.9	18.0	F
	Right Turn	700	610	87.1%	3.5	426.9	42.3	F
	Subtotal	2,390	2,132	89.2%	5.4	247.9	14.3	F
SB	Left Turn	250	228	91.3%	1.4	176.6	23.5	F
	Through	1,290	1,209	93.7%	2.3	57.2	5.2	E
	Right Turn	60	57	95.7%	0.3	37.6	9.1	D
	Subtotal	1,600	1,494	93.4%	2.7	75.3	7.8	E
EB	Left Turn	50	41	82.0%	1.3	426.6	34.2	F
	Through	290	244	84.1%	2.8	467.6	35.8	F
	Right Turn	130	104	79.8%	2.4	517.8	42.7	F
	Subtotal	470	389	82.7%	3.9	476.6	35.4	F
WB	Left Turn	630	545	86.5%	3.5	56.8	5.5	E
	Through	310	263	84.9%	2.8	64.6	6.6	E
	Right Turn	180	103	57.1%	6.5	26.0	5.8	C
	Subtotal	1,122	911	81.2%	6.6	69.3	9.4	E
Total		5,582	4,925	88.2%	9.1	174.3	8.0	F

Intersection 63 Meadow Drive/Alma Street Signal

Direction	Movement	Volume (vph)		Percent Served	Total Delay (sec/veh)			
		Demand	Served		GEH	Average	Std. Dev.	LOS
NB	Left Turn	70	62	88.7%	1.0	96.9	8.5	F
	Through	1,540	1,445	93.8%	2.5	62.5	9.9	E
	Right Turn	60	51	84.5%	1.3	51.7	19.8	D
	Subtotal	1,670	1,557	93.3%	2.8	63.9	9.5	E
SB	Left Turn	60	61	101.3%	0.1	147.6	16.9	F
	Through	680	684	100.6%	0.1	36.4	3.5	D
	Right Turn	180	187	103.7%	0.5	13.8	2.8	B
	Subtotal	920	931	101.2%	0.4	39.5	3.3	D
EB	Left Turn	190	172	90.5%	1.3	213.7	5.3	F
	Through	200	192	96.2%	0.5	217.1	7.0	F
	Right Turn	130	119	91.2%	1.0	211.2	11.1	F
	Subtotal	520	483	92.9%	1.7	214.4	3.8	F
WB	Left Turn	130	115	88.6%	1.3	250.8	27.7	F
	Through	300	265	88.2%	2.1	263.5	34.2	F
	Right Turn	90	78	86.3%	1.3	243.8	32.5	F
	Subtotal	520	458	88.0%	2.8	256.8	31.1	F
Total		3,630	3,429	94.5%	3.4	104.2	5.5	F

Intersection 68 Alma Street/Charleston Road Signal

Direction	Movement	Volume (vph)		Percent Served	Total Delay (sec/veh)			
		Demand	Served		GEH	Average	Std. Dev.	LOS
NB	Left Turn	310	272	87.7%	2.2	463.4	63.7	F
	Through	1,430	1,326	92.7%	2.8	199.4	43.2	F
	Right Turn	50	46	92.0%	0.6	192.5	35.9	F
	Subtotal	1,790	1,644	91.8%	3.5	239.7	44.9	F
SB	Left Turn	80	72	90.3%	0.9	237.3	73.9	F
	Through	830	801	96.4%	1.0	36.6	4.3	D
	Right Turn	80	75	94.1%	0.5	20.4	6.6	C
	Subtotal	990	948	95.8%	1.3	49.9	9.6	D
EB	Left Turn	130	123	94.5%	0.6	56.1	10.3	E
	Through	430	422	98.0%	0.4	60.9	3.1	E
	Right Turn	120	205	170.7%	6.7	56.8	5.0	E
	Subtotal	680	749	110.2%	2.6	59.0	2.7	E
WB	Left Turn	80	84	104.5%	0.4	129.7	39.1	F
	Through	300	295	98.2%	0.3	135.9	49.3	F
	Right Turn	110	114	103.9%	0.4	138.7	61.0	F
	Subtotal	490	492	100.5%	0.1	135.5	49.8	F
Total		3,950	3,833	97.0%	1.9	144.1	11.6	F

Intersection 67 Meadow Drive/Park Ave Side-street Stop

Direction	Movement	Volume (vph)		Percent Served	Total Delay (sec/veh)			
		Demand	Served		GEH	Average	Std. Dev.	LOS
NB	Left Turn	10	7	73.0%	0.9	929.8	572.2	F
	Through							
	Right Turn	40	23	57.5%	3.0	1278.3	243.3	F
	Subtotal	50	30	60.6%	3.1	1171.2	291.2	F
SB	Left Turn							
	Through							
	Right Turn							
	Subtotal							
EB	Left Turn							
	Through	480	462	96.1%	0.9	157.8	38.4	F
	Right Turn	10	9	93.0%	0.2	111.4	81.6	F
	Subtotal	490	471	96.1%	0.9	156.9	38.2	F
WB	Left Turn							
	Through	450	420	93.4%	1.4	1.2	0.4	A
	Right Turn	100	93	92.7%	0.7	2.1	0.8	A
	Subtotal	550	513	93.3%	1.6	1.3	0.5	A
Total		1,090	1,014	93.0%	2.3	111.8	25.6	F

Intersection 63 Meadow Drive/Alma Street Signal

Direction	Movement	Volume (vph)		Percent Served	Total Delay (sec/veh)			
		Demand	Served		GEH	Average	Std. Dev.	LOS
NB	Left Turn	100	91	91.2%	0.9	80.4	16.9	F
	Through	1,170	1,104	94.3%	2.0	40.4	11.2	D
	Right Turn	80	73	91.4%	0.8	39.6	11.7	D
	Subtotal	1,350	1,268	93.9%	2.3	43.6	11.7	D
SB	Left Turn	70	62	88.0%	1.0	397.4	35.8	F
	Through	1,435	1,250	87.1%	5.0	279.7	27.3	F
	Right Turn	100	86	85.6%	1.5	257.2	27.9	F
	Subtotal	1,605	1,397	87.1%	5.4	284.8	28.0	F
EB	Left Turn	130	117	90.2%	1.1	220.5	12.8	F
	Through	200	188	94.1%	0.8	222.3	11.3	F
	Right Turn	150	134	89.1%	1.4	215.3	10.1	F
	Subtotal	480	439	91.5%	1.9	219.6	5.0	F
WB	Left Turn	80	79	98.3%	0.2	130.0	40.2	F
	Through	310	301	97.1%	0.5	134.1	40.6	F
	Right Turn	80	74	92.6%	0.7	116.0	43.9	F
	Subtotal	470	454	96.5%	0.8	130.1	40.7	F
Total		3,905	3,558	91.1%	5.7	171.1	15.4	F

Intersection 68 Alma Street/Charleston Road Signal

Direction	Movement	Volume (vph)		Percent Served	Total Delay (sec/veh)			
		Demand	Served		GEH	Average	Std. Dev.	LOS
NB	Left Turn	330	308	93.4%	1.2	230.3	20.3	F
	Through	1,130	1,108	98.0%	0.7	177.5	17.9	F
	Right Turn	80	78	97.1%	0.3	174.7	19.3	F
	Subtotal	1,540	1,494	97.0%	1.2	189.8	11.0	F
SB	Left Turn	210	180	85.8%	2.1	147.7	11.6	F
	Through	1,380	1,201	87.0%	5.0	83.8	10.9	F
	Right Turn	100	88	88.2%	1.2	58.4	15.8	E
	Subtotal	1,690	1,469	86.9%	5.6	88.6	9.5	F
EB	Left Turn	90	72	80.2%	2.0	222.0	11.9	F
	Through	560	449	80.2%	4.9	231.0	4.8	F
	Right Turn	300	240	80.0%	3.7	229.5	4.7	F
	Subtotal	950	761	80.1%	6.5	229.7	3.5	F
WB	Left Turn	60	49	82.2%	1.4	187.2	75.3	F
	Through	450	373	82.8%	3.8	195.9	57.3	F
	Right Turn	110	89	80.5%	2.2	180.2	55.4	F
	Subtotal	620	511	82.4%	4.6	192.8	58.0	F
Total		4,800	4,234	88.2%	8.4	162.2	3.2	F

Intersection 67 Meadow Drive/Park Ave Side-street Stop

Direction	Movement	Volume (vph)		Percent Served	Total Delay (sec/veh)			
		Demand	Served		GEH	Average	Std. Dev.	LOS
NB	Left Turn	10	8	82.0%	0.6	560.8	527.2	F
	Through							
	Right Turn	20	14	70.0%	1.5	936.1	604.1	F
	Subtotal	30	22	74.0%	1.5	752.0	471.0	F
SB	Left Turn							
	Through							
	Right Turn	20	17	85.0%	0.7	7.7	3.4	A
	Subtotal	20	17	85.0%	0.7	7.7	3.4	A
EB	Left Turn							
	Through	460	427	92.8%	1.6	142.8	24.0	F
	Right Turn	20	18	88.5%	0.5	130.0	13.5	F
	Subtotal	480	445	92.6%	1.6	142.0	23.2	F
WB	Left Turn							
	Through	410	384	93.6%	1.3	1.3	0.6	A
	Right Turn	100	93	93.2%	0.7	2.8	1.1	A
	Subtotal	510	477	93.5%	1.5	1.6	0.6	A
Total		1,040	961	92.4%	2.5	95.7	15.1	F

Intersection 66

Alma Street/Churchill Street

Signal

Direction	Movement	Volume (vph)		Percent Served	GEH	Total Delay (sec/veh)		
		Demand	Served			Average	Std. Dev.	LOS
NB	Left Turn	240	222	92.4%	1.2	317.7	84.9	F
	Through	1,250	1,229	98.3%	0.6	74.8	27.3	E
	Right Turn	30	30	99.0%	0.1	72.2	21.7	E
	Subtotal	1,520	1,481	97.4%	1.0	113.7	33.1	F
SB	Left Turn	10	11	110.0%	0.3	149.6	79.7	F
	Through	630	629	99.9%	0.0	36.3	4.0	D
	Right Turn	200	199	99.3%	0.1	18.1	3.1	B
	Subtotal	840	839	99.9%	0.0	33.5	3.8	C
EB	Left Turn	60	60	99.8%	0.0	50.0	13.4	D
	Through	150	149	99.6%	0.0	46.3	5.2	D
	Right Turn	100	100	99.9%	0.0	15.3	2.3	B
	Subtotal	310	309	99.7%	0.0	36.3	4.7	D
WB	Left Turn	110	108	98.4%	0.2	148.8	65.5	F
	Through	60	47	77.8%	1.8	143.5	69.5	F
	Right Turn	20	18	92.0%	0.4	142.6	58.5	F
	Subtotal	190	173	91.2%	1.2	145.7	66.2	F
Total		2,860	2,802	98.0%	1.1	83.9	13.8	F

Intersection 66

Alma Street/Churchill Street

Signal

Direction	Movement	Volume (vph)		Percent Served	GEH	Total Delay (sec/veh)		
		Demand	Served			Average	Std. Dev.	LOS
NB	Left Turn	160	149	93.2%	0.9	151.6	10.4	F
	Through	790	799	101.2%	0.3	32.7	3.7	C
	Right Turn	60	56	92.7%	0.6	47.8	7.6	D
	Subtotal	1,010	1,004	99.4%	0.2	53.4	4.6	D
SB	Left Turn	30	30	101.3%	0.1	318.5	44.1	F
	Through	1,530	1,440	94.1%	2.3	182.2	16.2	F
	Right Turn	130	119	91.5%	1.0	172.3	20.3	F
	Subtotal	1,690	1,589	94.0%	2.5	184.7	16.6	F
EB	Left Turn	180	144	80.1%	2.8	163.0	11.5	F
	Through	260	205	78.8%	3.6	163.0	7.6	F
	Right Turn	260	215	82.6%	2.9	135.5	7.7	F
	Subtotal	700	564	80.5%	5.4	152.8	7.6	F
WB	Left Turn	110	103	93.7%	0.7	258.4	61.7	F
	Through	140	123	88.1%	1.4	270.2	66.2	F
	Right Turn	20	16	81.5%	0.9	251.0	57.8	F
	Subtotal	270	243	89.9%	1.7	263.6	62.8	F
Total		3,670	3,400	92.6%	4.5	141.9	7.1	F

Intersection 70

Rengstorff/Central Expressway

Signal

Direction	Movement	Volume (vph)		Percent Served	Total Delay (sec/veh)		
		Demand	Served		Average	Std. Dev.	LOS
NB	Left Turn	190	155	81.6%	162.0	10.1	F
	Through	570	454	79.7%	191.5	8.7	F
	Right Turn	220	180	82.0%	216.7	13.4	F
	Subtotal	980	790	80.6%	192.1	9.4	F
SB	Left Turn	60	59	98.3%	149.9	40.3	F
	Through	350	350	100.1%	174.1	30.8	F
	Right Turn	130	129	99.4%	180.8	39.9	F
	Subtotal	540	538	99.7%	172.9	32.7	F
EB	Left Turn	150	149	99.1%	158.3	73.8	F
	Through	920	918	99.7%	43.8	11.0	D
	Right Turn	120	122	101.6%	29.7	10.2	C
	Subtotal	1,190	1,188	99.8%	59.0	18.3	E
WB	Left Turn	160	147	92.1%	304.9	33.8	F
	Through	1,520	1,355	89.2%	250.1	11.3	F
	Right Turn	250	230	91.8%	161.7	6.9	F
	Subtotal	1,930	1,732	89.8%	242.7	10.1	F
Total		4,640	4,249	91.6%	168.6	6.0	F

Intersection 71

Moffett/Central Expressway

Signal

Direction	Movement	Volume (vph)		Percent Served	Total Delay (sec/veh)		
		Demand	Served		Average	Std. Dev.	LOS
NB	Left Turn	220	211	96.0%	58.7	10.4	E
	Through	280	315	112.4%	60.3	8.3	E
	Right Turn	130	133	102.1%	54.0	9.7	D
	Subtotal	630	659	104.6%	58.8	8.0	E
SB	Left Turn	60	57	95.5%	85.0	39.7	F
	Through	140	145	103.9%	79.3	22.0	E
	Right Turn	280	288	102.8%	60.6	25.0	E
	Subtotal	480	491	102.2%	68.2	23.5	E
EB	Left Turn	310	293	94.4%	329.9	37.9	F
	Through	1,070	991	92.6%	116.4	13.3	F
	Right Turn	150	136	90.5%	70.6	23.1	E
	Subtotal	1,530	1,419	92.8%	156.7	16.2	F
WB	Left Turn	130	87	67.0%	444.8	36.9	F
	Through	1,570	1,025	65.3%	348.1	22.3	F
	Right Turn	160	103	64.1%	336.2	27.9	F
	Subtotal	1,860	1,214	65.3%	353.1	21.0	F
Total		4,500	3,783	84.1%	196.7	9.1	F

VISSIM Post-Processor
Average Results from 10 Runs
Volume and Delay by Movement

Caltrain Electrification
2020 No Project
PM Peak Hour

Intersection 70

Rengstorff/Central Expressway

Signal

Direction	Movement	Volume (vph)		Percent Served	Total Delay (sec/veh)		
		Demand	Served		Average	Std. Dev.	LOS
NB	Left Turn	140	120	86.0%	234.0	26.0	F
	Through	450	382	84.9%	266.1	28.6	F
	Right Turn	130	111	85.7%	292.5	43.7	F
	Subtotal	720	614	85.3%	266.2	30.6	F
SB	Left Turn	180	163	90.3%	228.8	11.5	F
	Through	630	590	93.6%	249.2	11.5	F
	Right Turn	80	73	91.5%	258.5	22.0	F
	Subtotal	890	825	92.7%	246.6	10.7	F
EB	Left Turn	160	157	98.2%	174.6	20.5	F
	Through	1,320	1,276	96.7%	81.7	13.6	F
	Right Turn	240	236	98.3%	69.3	12.5	E
	Subtotal	1,720	1,669	97.0%	88.7	13.6	F
WB	Left Turn	160	143	89.1%	414.3	101.3	F
	Through	1,180	1,054	89.4%	192.0	25.3	F
	Right Turn	130	119	91.8%	85.8	13.9	F
	Subtotal	1,470	1,316	89.5%	211.2	36.8	F
Total		4,800	4,424	92.2%	179.2	13.6	F

Intersection 71

Moffett/Central Expressway

Signal

Direction	Movement	Volume (vph)		Percent Served	Total Delay (sec/veh)		
		Demand	Served		Average	Std. Dev.	LOS
NB	Left Turn	140	131	93.6%	74.1	8.8	E
	Through	390	363	92.9%	80.0	10.2	E
	Right Turn	180	163	90.3%	85.0	10.7	F
	Subtotal	710	656	92.4%	80.2	9.7	F
SB	Left Turn	210	166	78.8%	216.8	25.3	F
	Through	500	414	82.8%	218.1	26.4	F
	Right Turn	90	77	85.1%	190.8	34.1	F
	Subtotal	800	656	82.0%	214.5	26.2	F
EB	Left Turn	410	286	69.8%	308.8	97.1	F
	Through	1,610	1,162	72.2%	185.8	24.8	F
	Right Turn	200	144	72.0%	131.8	20.5	F
	Subtotal	2,220	1,592	71.7%	204.7	38.0	F
WB	Left Turn	240	164	68.3%	348.9	24.0	F
	Through	1,510	1,091	72.2%	228.6	9.9	F
	Right Turn	110	78	70.6%	199.4	16.0	F
	Subtotal	1,860	1,332	71.6%	244.8	8.7	F
Total		5,590	4,237	75.8%	196.5	9.8	F

VISSIM Post-Processor
Average Results from 10 Runs
Volume and Delay by Movement

Caltrain Electrification 2020
No Project
AM Peak Period

Intersection 75

Mary/Evelyn

Signal

Direction	Movement	Volume (vph)		Percent Served	Total Delay (sec/veh)		
		Demand	Served		Average	Std. Dev.	LOS
NB	Left Turn	80	77	96.8%	75.8	15.2	E
	Through	1,180	1,190	100.8%	88.5	13.6	F
	Right Turn	40	42	104.8%	73.0	21.1	E
	Subtotal	1,300	1,309	100.7%	87.2	13.5	F
SB	Left Turn	70	69	98.9%	78.7	20.5	E
	Through	440	441	100.1%	50.2	8.6	D
	Right Turn	220	221	100.5%	63.4	14.3	E
	Subtotal	730	731	100.1%	57.2	9.8	E
EB	Left Turn	260	258	99.3%	115.5	34.3	F
	Through	140	149	106.7%	23.5	4.3	C
	Right Turn	40	37	93.0%	11.2	6.1	B
	Subtotal	440	445	101.1%	76.3	22.3	E
WB	Left Turn	80	83	103.6%	42.2	11.4	D
	Through	290	286	98.7%	32.3	8.6	C
	Right Turn	220	219	99.7%	29.9	12.6	C
	Subtotal	590	589	99.7%	32.7	9.5	C
Total		3,060	3,073	100.4%	68.7	5.9	E

VISSIM Post-Processor
Average Results from 10 Runs
Volume and Delay by Movement

Catrain Electrification
2020 No Project
PM Peak Hour

Intersection 75

Mary/Evelyn

Signal

Direction	Movement	Volume (vph)		Percent Served	Total Delay (sec/veh)		
		Demand	Served		Average	Std. Dev.	LOS
NB	Left Turn	40	40	101.0%	46.9	12.3	D
	Through	490	485	98.9%	48.2	8.3	D
	Right Turn	40	43	106.8%	23.9	15.0	C
	Subtotal	570	568	99.6%	46.0	7.5	D
SB	Left Turn	260	224	86.3%	101.4	6.5	F
	Through	1,720	1,491	86.7%	99.2	9.4	F
	Right Turn	410	357	87.0%	117.1	14.0	F
	Subtotal	2,390	2,072	86.7%	102.8	8.3	F
EB	Left Turn	250	251	100.5%	162.5	41.8	F
	Through	390	383	98.2%	34.7	5.3	C
	Right Turn	110	108	98.0%	28.1	6.8	C
	Subtotal	750	742	98.9%	76.8	19.1	E
WB	Left Turn	60	58	97.3%	51.4	5.8	D
	Through	190	190	99.7%	36.4	3.9	D
	Right Turn	150	151	100.7%	19.9	2.2	B
	Subtotal	400	399	99.7%	32.1	2.2	C
Total		4,110	3,781	92.0%	80.1	3.5	F

2020 Project



Intersection 1

4th Street/King Street

Signal

Direction	Movement	Volume (vph)		Percent Served	GEH	Total Delay (sec/veh)		
		Demand	Served			Average	Std. Dev.	LOS
NB	Left Turn	20	10	48.5%	2.7	64.1	28.0	E
	Through	70	76	108.9%	0.7	31.4	10.3	C
	Right Turn	50	37	73.0%	2.1	14.0	8.2	B
	Subtotal	140	122	87.4%	1.5	29.4	8.9	C
SB	Left Turn	140	134	96.0%	0.5	85.2	15.7	F
	Through	510	411	80.6%	4.6	52.7	9.4	D
	Right Turn	310	283	91.2%	1.6	39.6	8.1	D
	Subtotal	960	828	86.3%	4.4	53.9	4.9	D
EB	Left Turn	110	95	86.5%	1.5	376.4	19.4	F
	Through	1,590	1,396	87.8%	5.0	197.6	20.0	F
	Right Turn	10	9	88.0%	0.4	83.1	54.3	F
	Subtotal	1,710	1,500	87.7%	5.3	208.1	19.6	F
WB	Left Turn	30	47	157.7%	2.8	92.0	22.9	F
	Through	990	759	76.6%	7.8	50.4	11.6	D
	Right Turn	20	47	235.5%	4.7	38.9	22.0	D
	Subtotal	1,040	853	82.0%	6.1	52.5	11.5	D
Total		3,850	3,304	85.8%	9.1	122.5	8.6	F

Intersection 2

4th Street/Townsend Street

Signal

Direction	Movement	Volume (vph)		Percent Served	GEH	Total Delay (sec/veh)		
		Demand	Served			Average	Std. Dev.	LOS
NB	Left Turn							
	Through	30	30	99.0%	0.1	40.8	10.8	D
	Right Turn	170	182	106.8%	0.9	26.8	8.4	C
	Subtotal	200	211	105.7%	0.8	29.1	8.3	C
SB	Left Turn							
	Through	580	565	97.3%	0.6	196.6	48.8	F
	Right Turn	80	68	84.5%	1.4	307.2	107.4	F
	Subtotal	660	632	95.8%	1.1	209.4	53.7	F
EB	Left Turn							
	Through	460	471	102.3%	0.5	165.8	122.3	F
	Right Turn	170	142	83.3%	2.3	337.7	158.8	F
	Subtotal	630	612	97.2%	0.7	213.7	134.5	F
WB	Left Turn	210	177	84.5%	2.3	102.0	37.0	F
	Through	220	233	105.8%	0.9	14.5	4.7	B
	Right Turn							
	Subtotal	430	410	95.4%	1.0	56.7	21.3	E
Total		1,920	1,866	97.2%	1.2	148.2	31.4	F

Intersection 1

4th Street/King Street

Signal

Direction	Movement	Volume (vph)		Percent Served	GEH	Total Delay (sec/veh)		
		Demand	Served			Average	Std. Dev.	LOS
NB	Left Turn	20	21	102.5%	0.1	64.1	16.1	E
	Through	70	113	160.7%	4.4	27.9	5.8	C
	Right Turn	50	57	114.8%	1.0	15.9	4.9	B
	Subtotal	140	190	136.0%	3.9	28.7	4.8	C
SB	Left Turn	150	99	66.1%	4.6	82.7	13.9	F
	Through	400	291	72.8%	5.9	55.4	7.6	E
	Right Turn	700	482	68.9%	8.9	43.3	4.9	D
	Subtotal	1,250	873	69.8%	11.6	52.5	5.2	D
EB	Left Turn	140	80	56.9%	5.8	485.5	52.9	F
	Through	1,420	881	62.1%	15.9	385.1	36.5	F
	Right Turn	20	13	62.5%	1.9	203.5	146.9	F
	Subtotal	1,580	973	61.6%	17.0	390.1	35.7	F
WB	Left Turn	20	20	98.5%	0.1	285.2	41.3	F
	Through	990	978	98.8%	0.4	273.0	25.4	F
	Right Turn	30	57	189.3%	4.1	168.4	38.7	F
	Subtotal	1,040	1,055	101.4%	0.5	267.8	25.6	F
Total		4,010	3,091	77.1%	15.4	229.4	18.6	F

Intersection 2

4th Street/Townsend Street

Signal

Direction	Movement	Volume (vph)		Percent Served	GEH	Total Delay (sec/veh)		
		Demand	Served			Average	Std. Dev.	LOS
NB	Left Turn							
	Through	20	12	61.5%	1.9	35.5	27.8	D
	Right Turn	220	189	85.9%	2.2	25.6	6.6	C
	Subtotal	240	201	83.8%	2.6	26.1	7.9	C
SB	Left Turn							
	Through	760	529	69.6%	9.1	380.3	41.2	F
	Right Turn	90	57	63.1%	3.9	612.7	72.9	F
	Subtotal	850	586	68.9%	9.9	404.3	37.8	F
EB	Left Turn							
	Through	340	352	103.6%	0.7	36.3	5.3	D
	Right Turn	150	139	92.9%	0.9	93.3	44.1	F
	Subtotal	490	492	100.3%	0.1	53.2	16.8	D
WB	Left Turn	340	261	76.7%	4.6	347.4	34.5	F
	Through	310	258	83.3%	3.1	141.0	15.8	F
	Right Turn							
	Subtotal	650	519	79.9%	5.4	250.3	25.3	F
Total		2,230	1,798	80.6%	9.6	226.7	8.6	F

Intersection 5

7th Street/16th Street

Signal

Direction	Movement	Volume (vph)		Percent Served	GEH	Total Delay (sec/veh)		
		Demand	Served			Average	Std. Dev.	LOS
NB	Left Turn	170	167	98.4%	0.2	127.2	29.2	F
	Through	390	367	94.0%	1.2	122.4	31.4	F
	Right Turn	110	101	92.0%	0.9	107.9	35.8	F
	Subtotal	670	635	94.8%	1.4	121.4	31.0	F
SB	Left Turn	120	117	97.2%	0.3	158.0	38.5	F
	Through	100	98	97.7%	0.2	108.2	52.4	F
	Right Turn	40	44	109.0%	0.6	89.5	39.8	F
	Subtotal	260	258	99.2%	0.1	127.4	38.3	F
EB	Left Turn	40	39	97.8%	0.1	153.0	48.8	F
	Through	390	389	99.7%	0.1	148.7	43.0	F
	Right Turn	110	113	102.3%	0.2	131.1	37.9	F
	Subtotal	540	541	100.1%	0.0	145.4	41.2	F
WB	Left Turn	80	70	88.0%	1.1	236.7	112.2	F
	Through	220	207	94.1%	0.9	87.5	19.4	F
	Right Turn	170	164	96.2%	0.5	38.7	10.6	D
	Subtotal	470	441	93.8%	1.4	88.8	26.3	F
Total		1,940	1,875	96.6%	1.5	120.6	14.6	F

Intersection 6

Owens Street/16th Street

Signal

Direction	Movement	Volume (vph)		Percent Served	GEH	Total Delay (sec/veh)		
		Demand	Served			Average	Std. Dev.	LOS
NB	Left Turn							
	Through							
	Right Turn							
	Subtotal							
SB	Left Turn	60	60	100.5%	0.0	20.2	3.5	C
	Through							
	Right Turn	110	109	99.5%	0.1	6.0	0.7	A
	Subtotal	170	170	99.8%	0.0	11.3	1.3	B
EB	Left Turn	250	250	100.2%	0.0	21.2	4.9	C
	Through	370	358	96.7%	0.6	4.2	1.4	A
	Right Turn							
	Subtotal	620	608	98.1%	0.5	11.3	2.3	B
WB	Left Turn							
	Through	340	331	97.5%	0.5	13.0	1.1	B
	Right Turn	120	126	104.8%	0.5	9.2	1.5	A
	Subtotal	460	457	99.4%	0.1	12.0	1.1	B
Total		1,250	1,235	98.8%	0.4	11.6	1.5	B

Intersection 5

7th Street/16th Street

Signal

Direction	Movement	Volume (vph)		Percent Served	GEH	Total Delay (sec/veh)		
		Demand	Served			Average	Std. Dev.	LOS
NB	Left Turn	230	228	99.3%	0.1	72.4	20.5	E
	Through	350	350	99.9%	0.0	70.4	18.0	E
	Right Turn	50	49	98.2%	0.1	47.6	11.0	D
	Subtotal	630	627	99.5%	0.1	69.3	18.2	E
SB	Left Turn	80	76	95.1%	0.4	74.2	22.8	E
	Through	140	144	102.9%	0.3	77.3	23.1	E
	Right Turn	40	39	96.3%	0.2	60.1	25.2	E
	Subtotal	260	259	99.5%	0.1	74.1	20.4	E
EB	Left Turn	50	49	98.2%	0.1	107.2	36.6	F
	Through	430	434	100.8%	0.2	70.7	17.6	E
	Right Turn	80	77	95.9%	0.4	53.7	11.1	D
	Subtotal	560	559	99.9%	0.0	72.1	16.3	E
WB	Left Turn	110	113	102.3%	0.2	134.3	25.5	F
	Through	450	451	100.3%	0.1	46.1	9.6	D
	Right Turn	300	300	99.9%	0.0	31.2	7.1	C
	Subtotal	860	864	100.4%	0.1	52.5	10.1	D
Total		2,310	2,309	99.9%	0.0	64.5	8.5	E

Intersection 6

Owens Street/16th Street

Signal

Direction	Movement	Volume (vph)		Percent Served	GEH	Total Delay (sec/veh)		
		Demand	Served			Average	Std. Dev.	LOS
NB	Left Turn							
	Through							
	Right Turn							
	Subtotal							
SB	Left Turn	140	139	99.4%	0.1	18.2	3.3	B
	Through							
	Right Turn	200	198	98.9%	0.2	11.4	6.3	B
	Subtotal	340	337	99.1%	0.2	14.3	5.0	B
EB	Left Turn	110	113	103.1%	0.3	21.3	4.8	C
	Through	450	444	98.7%	0.3	5.9	2.0	A
	Right Turn							
	Subtotal	560	558	99.6%	0.1	9.2	2.3	A
WB	Left Turn							
	Through	660	662	100.4%	0.1	17.4	3.5	B
	Right Turn	90	87	96.2%	0.4	14.1	4.5	B
	Subtotal	750	749	99.9%	0.0	17.0	3.6	B
Total		1,650	1,644	99.6%	0.2	13.7	2.9	B

VISSIM Post-Processor
Average Results from 10 Runs
Volume and Delay by Movement

Caltrain Electrification
2020 Project
AM Peak Hour

Intersection 18

California/Broadway

Signal

Direction	Movement	Volume (vph)		Percent Served	Total Delay (sec/veh)		
		Demand	Served		Average	Std. Dev.	LOS
NB	Left Turn	30	30	98.3%	64.0	25.4	E
	Through	280	280	100.1%	51.3	6.6	D
	Right Turn	530	529	99.8%	18.4	3.5	B
	Subtotal	840	839	99.8%	30.1	4.0	C
SB	Left Turn	440	402	91.4%	151.0	14.2	F
	Through	400	369	92.2%	122.7	14.5	F
	Right Turn	30	30	100.7%	113.0	23.1	F
	Subtotal	870	801	92.1%	136.4	13.2	F
EB	Left Turn	10	10	95.0%	67.8	42.9	E
	Through	380	373	98.2%	62.6	9.0	E
	Right Turn	40	40	99.3%	46.7	19.4	D
	Subtotal	430	422	98.2%	61.8	9.4	E
WB	Left Turn	260	261	100.3%	19.7	4.0	B
	Through	360	345	95.9%	7.1	1.1	A
	Right Turn	260	262	100.7%	1.1	0.6	A
	Subtotal	880	868	98.6%	8.8	1.0	A
Total		3,020	2,930	97.0%	65.2	1.5	E

Intersection 19

Carolan/Broadway

Signal

Direction	Movement	Volume (vph)		Percent Served	Total Delay (sec/veh)		
		Demand	Served		Average	Std. Dev.	LOS
NB	Left Turn	100	100	99.6%	209.6	65.6	F
	Through	1	12	1160.0%	187.0	86.5	F
	Right Turn	410	408	99.5%	23.0	7.7	C
	Subtotal	511	519	101.6%	74.6	24.2	E
SB	Left Turn						
	Through						
	Right Turn						
	Subtotal						
EB	Left Turn	10	9	92.0%	37.2	21.0	D
	Through	1,170	1,130	96.6%	2.6	0.5	A
	Right Turn	170	164	96.7%	3.1	1.3	A
	Subtotal	1,350	1,304	96.6%	3.1	0.7	A
WB	Left Turn	150	149	99.1%	118.8	44.2	F
	Through	780	768	98.5%	18.0	4.5	B
	Right Turn	10	12	122.0%	10.8	9.3	B
	Subtotal	940	929	98.8%	35.0	9.3	C
Total		2,801	2,752	98.2%	28.8	4.9	C

VISSIM Post-Processor
Average Results from 10 Runs
Volume and Delay by Movement

Caltrain Electrification
2020 Project
PM Peak Hour

Intersection 18

California/Broadway

Signal

Direction	Movement	Volume (vph)		Percent Served	Total Delay (sec/veh)		
		Demand	Served		Average	Std. Dev.	LOS
NB	Left Turn	120	119	99.1%	72.9	10.6	E
	Through	340	337	99.2%	64.9	5.6	E
	Right Turn	340	341	100.2%	14.2	3.8	B
	Subtotal	800	797	99.6%	43.7	3.7	D
SB	Left Turn	420	302	72.0%	165.6	13.9	F
	Through	410	307	74.8%	165.5	13.3	F
	Right Turn	60	42	70.7%	148.7	17.8	F
	Subtotal	890	651	73.2%	164.3	12.9	F
EB	Left Turn	20	20	102.0%	129.3	21.8	F
	Through	320	320	100.0%	76.1	9.2	E
	Right Turn	50	49	98.2%	53.9	19.2	D
	Subtotal	390	389	99.8%	76.1	9.8	E
WB	Left Turn	360	335	92.9%	13.5	1.3	B
	Through	480	443	92.3%	8.2	0.9	A
	Right Turn	460	445	96.8%	1.5	0.5	A
	Subtotal	1,300	1,223	94.1%	6.9	0.4	A
Total		3,380	3,061	90.6%	62.4	3.3	E

Intersection 19

Carolan/Broadway

Signal

Direction	Movement	Volume (vph)		Percent Served	Total Delay (sec/veh)		
		Demand	Served		Average	Std. Dev.	LOS
NB	Left Turn	110	113	102.3%	170.2	49.2	F
	Through	10	9	93.0%	120.4	60.0	F
	Right Turn	400	396	98.9%	15.3	4.4	B
	Subtotal	520	517	99.5%	43.5	9.2	D
SB	Left Turn						
	Through						
	Right Turn						
	Subtotal						
EB	Left Turn	10	10	96.0%	31.1	28.0	C
	Through	960	857	89.3%	2.6	0.4	A
	Right Turn	110	97	88.2%	2.1	0.7	A
	Subtotal	1,080	964	89.3%	2.9	0.5	A
WB	Left Turn	280	253	90.4%	152.2	16.7	F
	Through	1,190	1,112	93.5%	58.0	15.8	E
	Right Turn	10	11	106.0%	60.3	24.1	E
	Subtotal	1,480	1,376	93.0%	76.2	15.1	E
Total		3,080	2,857	92.8%	44.5	6.7	D

Intersection 45 El Camino Real/Whipple Road Signal

Direction	Movement	Volume (vph)		Percent Served	GEH	Total Delay (sec/veh)		
		Demand	Served			Average	Std. Dev.	LOS
NB	Left Turn	60	57	94.7%	0.4	81.8	13.2	F
	Through	890	886	99.5%	0.2	48.0	10.4	D
	Right Turn	500	506	101.3%	0.3	24.1	12.2	C
	Subtotal	1,450	1,449	99.9%	0.0	41.5	10.7	D
SB	Left Turn	300	286	95.3%	0.8	104.0	10.7	F
	Through	1,080	1,073	99.4%	0.2	46.2	7.0	D
	Right Turn	70	70	100.1%	0.0	41.0	11.9	D
	Subtotal	1,450	1,429	98.6%	0.5	58.1	7.5	E
EB	Left Turn	110	107	97.0%	0.3	67.8	11.6	E
	Through	460	451	98.0%	0.4	69.5	10.2	E
	Right Turn	50	48	95.6%	0.3	63.8	18.7	E
	Subtotal	620	605	97.6%	0.6	68.9	10.5	E
WB	Left Turn	290	293	100.9%	0.2	40.0	3.4	D
	Through	290	289	99.7%	0.1	40.6	7.1	D
	Right Turn	280	283	100.9%	0.2	8.7	1.7	A
	Subtotal	860	864	100.5%	0.1	29.8	3.4	C
Total		4,380	4,348	99.3%	0.5	48.7	5.6	D

Intersection 62 Palo Alto/Alma Side-street Stop

Direction	Movement	Volume (vph)		Percent Served	GEH	Total Delay (sec/veh)		
		Demand	Served			Average	Std. Dev.	LOS
NB	Left Turn							
	Through							
	Right Turn							
	Subtotal							
SB	Left Turn	10	8	75.0%	0.8	7.0	3.1	A
	Through							
	Right Turn	30	30	99.3%	0.0	16.1	8.7	C
	Subtotal	40	37	93.3%	0.4	13.3	5.7	B
EB	Left Turn							
	Through	500	500	100.0%	0.0	11.9	3.5	B
	Right Turn							
	Subtotal	500	500	100.0%	0.0	11.9	3.5	B
WB	Left Turn							
	Through	530	527	99.5%	0.1	10.1	2.6	B
	Right Turn	20	20	102.0%	0.1	11.7	16.1	B
	Subtotal	550	548	99.6%	0.1	10.1	2.6	B
Total		1,090	1,085	99.6%	0.1	11.0	2.3	B

Intersection 64 El Camino Real/Sand Hill-Palo Alto Signal

Direction	Movement	Volume (vph)		Percent Served	GEH	Total Delay (sec/veh)		
		Demand	Served			Average	Std. Dev.	LOS
NB	Left Turn	140	137	97.9%	0.3	69.8	9.4	E
	Through	570	574	100.6%	0.2	44.5	4.2	D
	Right Turn	30	28	94.3%	0.3	20.7	11.7	C
	Subtotal	740	739	99.9%	0.0	48.1	3.3	D
SB	Left Turn	470	472	100.4%	0.1	146.2	76.4	F
	Through	1,330	1,316	98.9%	0.4	55.3	11.7	E
	Right Turn	690	660	95.7%	1.2	203.7	52.8	F
	Subtotal	2,490	2,448	98.3%	0.8	113.5	19.7	F
EB	Left Turn	290	296	101.9%	0.3	58.6	3.9	E
	Through							
	Right Turn	240	233	97.1%	0.4	9.5	1.6	A
	Subtotal	530	529	99.8%	0.1	37.0	3.0	D
WB	Left Turn							
	Through							
	Right Turn	560	557	99.5%	0.1	3.9	0.9	A
	Subtotal	560	557	99.5%	0.1	3.9	0.9	A
Total		4,320	4,272	98.9%	0.7	78.7	11.4	E

Intersection 45 El Camino Real/Whipple Road Signal

Direction	Movement	Volume (vph)		Percent Served	Total Delay (sec/veh)		
		Demand	Served		Average	Std. Dev.	LOS
NB	Left Turn	60	60	99.2%	67.4	9.9	E
	Through	1,280	1,275	99.6%	42.5	4.3	D
	Right Turn	290	292	100.8%	27.1	4.9	C
	Subtotal	1,630	1,627	99.8%	40.6	4.4	D
SB	Left Turn	250	253	101.2%	115.7	29.9	F
	Through	1,090	1,080	99.1%	32.5	6.7	C
	Right Turn	100	101	100.6%	29.2	5.6	C
	Subtotal	1,440	1,434	99.6%	48.1	8.7	D
EB	Left Turn	130	131	101.0%	105.4	20.5	F
	Through	240	252	105.2%	109.9	23.5	F
	Right Turn	60	54	90.3%	95.4	32.7	F
	Subtotal	430	438	101.8%	107.1	22.3	F
WB	Left Turn	340	347	102.1%	33.0	4.0	C
	Through	410	399	97.4%	31.1	3.1	C
	Right Turn	320	323	100.9%	13.1	2.0	B
	Subtotal	1,070	1,069	99.9%	26.3	2.1	C
Total		4,570	4,568	100.0%	45.2	3.3	D

Intersection 62 Palo Alto/Alma Side-street Stop

Direction	Movement	Volume (vph)		Percent Served	Total Delay (sec/veh)		
		Demand	Served		Average	Std. Dev.	LOS
NB	Left Turn						
	Through						
	Right Turn						
	Subtotal						
SB	Left Turn	10	10	97.0%	10.2	8.7	B
	Through						
	Right Turn	50	47	93.8%	34.5	10.5	D
	Subtotal	60	57	94.3%	31.4	9.4	D
EB	Left Turn						
	Through	560	552	98.6%	8.2	1.7	A
	Right Turn						
	Subtotal	560	552	98.6%	8.2	1.7	A
WB	Left Turn						
	Through	750	748	99.7%	9.4	1.4	A
	Right Turn	60	60	99.3%	4.3	2.0	A
	Subtotal	810	808	99.7%	9.0	1.4	A
Total		1,430	1,416	99.0%	9.6	1.5	A

Intersection 64 El Camino Real/Sand Hill-Palo Alto Signal

Direction	Movement	Volume (vph)		Percent Served	Total Delay (sec/veh)		
		Demand	Served		Average	Std. Dev.	LOS
NB	Left Turn	150	152	101.2%	58.4	6.5	E
	Through	1,290	1,288	99.8%	51.7	2.3	D
	Right Turn	150	149	99.5%	29.1	5.3	C
	Subtotal	1,590	1,589	99.9%	50.3	2.2	D
SB	Left Turn	410	404	98.5%	160.1	82.9	F
	Through	1,110	1,107	99.7%	36.0	3.5	D
	Right Turn	270	266	98.6%	14.1	3.0	B
	Subtotal	1,790	1,777	99.3%	62.9	23.4	E
EB	Left Turn	810	692	85.4%	94.9	5.5	F
	Through						
	Right Turn	300	260	86.5%	38.2	2.7	D
	Subtotal	1,110	951	85.7%	79.9	5.5	E
WB	Left Turn						
	Through						
	Right Turn	800	795	99.4%	6.5	1.0	A
	Subtotal	800	795	99.4%	6.5	1.0	A
Total		5,290	5,112	96.6%	53.5	8.6	D

Intersection 59

Alma Street/Ravenswood Ave

Side-street Stop

Direction	Movement	Volume (vph)		Percent Served	GEH	Total Delay (sec/veh)		
		Demand	Served			Average	Std. Dev.	LOS
NB	Left Turn	20	18	88.5%	0.5	23.8	12.5	C
	Through	10	11	108.0%	0.2	19.9	11.6	C
	Right Turn	10	10	97.0%	0.1	7.1	2.9	A
	Subtotal	40	38	95.5%	0.3	17.3	5.4	C
SB	Left Turn	10	13	129.0%	0.9	52.7	37.1	F
	Through	10	9	90.0%	0.3	18.2	12.9	C
	Right Turn	40	39	96.5%	0.2	24.7	14.3	C
	Subtotal	60	61	100.8%	0.1	29.8	20.9	D
EB	Left Turn	20	30	149.5%	2.0	24.4	7.7	C
	Through	680	673	99.0%	0.3	15.9	3.4	C
	Right Turn	210	216	102.8%	0.4	21.3	5.2	C
	Subtotal	910	919	101.0%	0.3	17.6	3.5	C
WB	Left Turn	10	11	105.0%	0.2	16.6	13.5	C
	Through	770	786	102.1%	0.6	14.3	3.0	B
	Right Turn	30	28	94.3%	0.3	11.8	9.3	B
	Subtotal	810	825	101.8%	0.5	14.3	3.1	B
Total		1,820	1,842	101.2%	0.5	16.5	3.1	C

Intersection 60

El Camino Real/Ravenswood Ave

Signal

Direction	Movement	Volume (vph)		Percent Served	GEH	Total Delay (sec/veh)		
		Demand	Served			Average	Std. Dev.	LOS
NB	Left Turn	100	102	102.2%	0.2	72.4	11.9	E
	Through	1,110	1,100	99.1%	0.3	48.5	2.8	D
	Right Turn	430	426	99.0%	0.2	27.4	12.2	C
	Subtotal	1,640	1,628	99.3%	0.3	44.3	3.5	D
SB	Left Turn	260	261	100.3%	0.0	140.4	15.2	F
	Through	1,410	1,399	99.2%	0.3	62.9	13.9	E
	Right Turn	30	33	108.3%	0.4	52.3	16.0	D
	Subtotal	1,700	1,692	99.5%	0.2	75.1	13.4	E
EB	Left Turn	20	19	93.5%	0.3	138.8	38.7	F
	Through	400	397	99.4%	0.1	171.8	33.0	F
	Right Turn	60	84	139.3%	2.8	142.4	42.0	F
	Subtotal	480	500	104.1%	0.9	166.6	33.4	F
WB	Left Turn	551	553	100.4%	0.1	75.9	11.3	E
	Through	271	281	103.8%	0.6	86.5	16.7	F
	Right Turn	100	95	94.8%	0.5	21.5	7.5	C
	Subtotal	922	929	100.8%	0.2	73.7	9.6	E
Total		4,742	4,749	100.1%	0.1	75.0	7.6	E

Intersection 59

Alma Street/Ravenswood Ave

Side-street Stop

Direction	Movement	Volume (vph)		Percent Served	GEH	Total Delay (sec/veh)		
		Demand	Served			Average	Std. Dev.	LOS
NB	Left Turn	30	31	102.0%	0.1	33.8	16.5	D
	Through	10	9	91.0%	0.3	39.5	30.4	E
	Right Turn	80	79	98.3%	0.2	19.8	11.8	C
	Subtotal	120	118	98.6%	0.2	24.4	12.2	C
SB	Left Turn	10	10	95.0%	0.2	28.9	17.4	D
	Through	10	10	99.0%	0.0	23.8	14.7	C
	Right Turn	50	37	74.6%	1.9	25.9	8.5	D
	Subtotal	70	57	81.0%	1.7	27.1	8.9	D
EB	Left Turn	20	16	81.5%	0.9	27.1	21.9	D
	Through	820	699	85.3%	4.4	15.7	3.7	C
	Right Turn	320	273	85.4%	2.7	23.2	5.5	C
	Subtotal	1,160	989	85.3%	5.2	16.1	3.2	C
WB	Left Turn	20	17	87.0%	0.6	22.6	17.5	C
	Through	820	804	98.1%	0.6	20.9	5.9	C
	Right Turn	30	30	99.7%	0.0	14.9	8.1	B
	Subtotal	870	852	97.9%	0.6	20.7	5.9	C
Total		2,220	2,016	90.8%	4.4	19.0	3.3	C

Intersection 60

El Camino Real/Ravenswood Ave

Signal

Direction	Movement	Volume (vph)		Percent Served	GEH	Total Delay (sec/veh)		
		Demand	Served			Average	Std. Dev.	LOS
NB	Left Turn	180	161	89.3%	1.5	154.9	18.0	F
	Through	1,510	1,313	87.0%	5.2	161.6	13.9	F
	Right Turn	700	596	85.1%	4.1	474.5	32.4	F
	Subtotal	2,390	2,070	86.6%	6.8	260.3	17.6	F
SB	Left Turn	250	219	87.6%	2.0	169.8	28.1	F
	Through	1,290	1,223	94.8%	1.9	52.7	8.7	D
	Right Turn	60	59	97.8%	0.2	38.3	10.4	D
	Subtotal	1,600	1,500	93.8%	2.5	69.4	11.6	E
EB	Left Turn	50	32	64.2%	2.8	395.8	30.8	F
	Through	290	254	87.6%	2.2	429.2	41.8	F
	Right Turn	130	107	82.3%	2.1	503.3	73.0	F
	Subtotal	470	393	83.7%	3.7	447.2	47.3	F
WB	Left Turn	630	514	81.5%	4.9	64.5	6.4	E
	Through	310	267	86.1%	2.5	67.7	9.2	E
	Right Turn	180	104	57.6%	6.4	25.0	6.1	C
	Subtotal	1,122	884	78.8%	7.5	65.5	5.9	E
Total		5,582	4,847	86.8%	10.2	176.1	7.5	F

Intersection 63 Meadow Drive/Alma Street Signal

Direction	Movement	Volume (vph)		Percent Served	Total Delay (sec/veh)			
		Demand	Served		GEH	Average	Std. Dev.	LOS
NB	Left Turn	130	120	92.0%	0.9	161.8	28.4	F
	Through	1,420	1,284	90.4%	3.7	104.4	14.4	F
	Right Turn	60	52	86.8%	1.1	99.0	20.6	F
	Subtotal	1,610	1,455	90.4%	4.0	109.1	15.2	F
SB	Left Turn	60	59	99.0%	0.1	173.1	66.1	F
	Through	680	694	102.0%	0.5	39.9	14.4	D
	Right Turn	160	161	100.7%	0.1	20.2	13.8	C
	Subtotal	900	914	101.6%	0.5	43.2	18.4	D
EB	Left Turn	180	177	98.3%	0.2	126.8	7.0	F
	Through	190	190	100.2%	0.0	132.0	5.5	F
	Right Turn	130	124	95.3%	0.5	126.7	5.0	F
	Subtotal	500	491	98.2%	0.4	128.8	2.8	F
WB	Left Turn	130	124	95.0%	0.6	236.3	15.5	F
	Through	240	222	92.6%	1.2	238.0	9.7	F
	Right Turn	90	88	97.6%	0.2	214.6	25.2	F
	Subtotal	460	434	94.3%	1.2	232.8	12.9	F
Total		3,470	3,294	94.9%	3.0	110.0	9.8	F

Intersection 68 Alma Street/Charleston Road Signal

Direction	Movement	Volume (vph)		Percent Served	Total Delay (sec/veh)			
		Demand	Served		GEH	Average	Std. Dev.	LOS
NB	Left Turn	350	304	86.9%	2.5	522.5	53.6	F
	Through	1,370	1,178	86.0%	5.4	261.7	37.0	F
	Right Turn	50	44	87.0%	1.0	248.7	60.5	F
	Subtotal	1,770	1,526	86.2%	6.0	320.9	42.4	F
SB	Left Turn	80	78	97.5%	0.2	276.6	111.2	F
	Through	840	829	98.6%	0.4	55.1	18.3	E
	Right Turn	80	79	98.1%	0.2	27.1	13.8	C
	Subtotal	1,000	985	98.5%	0.5	74.1	28.0	E
EB	Left Turn	130	129	99.0%	0.1	54.6	9.0	D
	Through	430	423	98.3%	0.3	55.2	2.8	E
	Right Turn	210	212	101.0%	0.1	47.7	4.8	D
	Subtotal	770	764	99.2%	0.2	53.0	2.2	D
WB	Left Turn	80	83	103.6%	0.3	86.4	26.4	F
	Through	280	288	102.8%	0.5	95.3	27.6	F
	Right Turn	110	114	103.9%	0.4	93.9	31.2	F
	Subtotal	470	485	103.2%	0.7	93.7	27.4	F
Total		4,010	3,760	93.8%	4.0	172.5	19.2	F

Intersection 67 Meadow Drive/Park Ave Side-street Stop

Direction	Movement	Volume (vph)		Percent Served	Total Delay (sec/veh)			
		Demand	Served		GEH	Average	Std. Dev.	LOS
NB	Left Turn	10	9	90.0%	0.3	153.7	108.4	F
	Through							
	Right Turn	30	28	92.3%	0.4	231.7	119.3	F
	Subtotal	40	37	91.8%	0.5	208.3	86.4	F
SB	Left Turn							
	Through							
	Right Turn							
	Subtotal							
EB	Left Turn							
	Through	470	467	99.3%	0.2	79.8	34.5	F
	Right Turn	10	10	98.0%	0.1	81.2	44.5	F
	Subtotal	480	476	99.3%	0.2	79.7	34.4	F
WB	Left Turn							
	Through	440	420	95.5%	0.9	1.0	0.3	A
	Right Turn	90	82	91.2%	0.9	1.6	0.8	A
	Subtotal	530	502	94.8%	1.2	1.1	0.3	A
Total		1,050	1,016	96.7%	1.1	47.3	18.3	E

Intersection 63 Meadow Drive/Alma Street Signal

Direction	Movement	Volume (vph)		Percent Served	Total Delay (sec/veh)			
		Demand	Served		GEH	Average	Std. Dev.	LOS
NB	Left Turn	70	58	83.3%	1.5	71.6	15.2	E
	Through	1,180	1,017	86.2%	4.9	36.6	8.1	D
	Right Turn	80	71	88.3%	1.1	34.1	13.3	C
	Subtotal	1,330	1,146	86.2%	5.2	38.7	7.9	D
SB	Left Turn	70	60	85.6%	1.3	447.1	28.5	F
	Through	1,410	1,114	79.0%	8.3	332.0	14.5	F
	Right Turn	150	116	77.3%	2.9	302.4	19.6	F
	Subtotal	1,630	1,290	79.1%	8.9	333.5	13.9	F
EB	Left Turn	130	124	95.7%	0.5	248.0	9.5	F
	Through	200	194	96.8%	0.5	245.7	3.3	F
	Right Turn	130	123	94.3%	0.7	243.7	7.7	F
	Subtotal	460	441	95.8%	0.9	245.9	2.9	F
WB	Left Turn	80	84	105.0%	0.4	190.0	55.6	F
	Through	280	285	101.9%	0.3	188.3	53.2	F
	Right Turn	80	81	101.6%	0.1	165.8	58.9	F
	Subtotal	440	451	102.4%	0.5	184.8	54.7	F
Total		3,860	3,327	86.2%	8.9	200.2	8.3	F

Intersection 68 Alma Street/Charleston Road Signal

Direction	Movement	Volume (vph)		Percent Served	Total Delay (sec/veh)			
		Demand	Served		GEH	Average	Std. Dev.	LOS
NB	Left Turn	270	234	86.6%	2.3	215.5	18.7	F
	Through	1,160	998	86.0%	4.9	187.2	18.3	F
	Right Turn	80	71	88.3%	1.1	186.9	18.5	F
	Subtotal	1,510	1,302	86.2%	5.5	192.6	15.5	F
SB	Left Turn	120	98	81.5%	2.1	199.1	29.0	F
	Through	1,440	1,194	82.9%	6.8	157.3	26.7	F
	Right Turn	110	91	83.0%	1.9	134.7	30.1	F
	Subtotal	1,670	1,383	82.8%	7.3	158.9	26.7	F
EB	Left Turn	110	97	87.8%	1.3	120.7	10.7	F
	Through	580	534	92.1%	1.9	122.3	4.4	F
	Right Turn	250	228	91.1%	1.4	119.4	6.3	F
	Subtotal	940	859	91.4%	2.7	121.3	3.1	F
WB	Left Turn	110	110	99.8%	0.0	223.9	25.2	F
	Through	420	410	97.7%	0.5	227.7	20.6	F
	Right Turn	60	57	94.7%	0.4	224.6	32.2	F
	Subtotal	590	577	97.8%	0.5	226.6	21.4	F
Total		4,710	4,121	87.5%	8.9	171.2	10.3	F

Intersection 67 Meadow Drive/Park Ave Side-street Stop

Direction	Movement	Volume (vph)		Percent Served	Total Delay (sec/veh)			
		Demand	Served		GEH	Average	Std. Dev.	LOS
NB	Left Turn	10	9	90.0%	0.3	219.3	202.1	F
	Through							
	Right Turn	20	19	93.0%	0.3	354.9	171.9	F
	Subtotal	30	28	92.0%	0.4	310.1	180.9	F
SB	Left Turn							
	Through							
	Right Turn	5	17	340.0%	3.6	7.1	2.5	A
	Subtotal	5	17	340.0%	3.6	7.1	2.5	A
EB	Left Turn							
	Through	440	421	95.7%	0.9	184.0	29.4	F
	Right Turn	20	18	91.5%	0.4	169.9	44.5	F
	Subtotal	460	439	95.5%	1.0	183.6	29.8	F
WB	Left Turn							
	Through	400	364	91.1%	1.8	1.0	0.4	A
	Right Turn	100	95	95.2%	0.5	2.2	0.9	A
	Subtotal	500	460	91.9%	1.8	1.2	0.4	A
Total		995	943	94.8%	1.7	88.5	8.4	F

Intersection 66

Alma Street/Churchill Street

Signal

Direction	Movement	Volume (vph)		Percent Served	GEH	Total Delay (sec/veh)		
		Demand	Served			Average	Std. Dev.	LOS
NB	Left Turn	240	212	88.5%	1.8	398.9	57.1	F
	Through	1,250	1,135	90.8%	3.3	124.3	34.5	F
	Right Turn	30	27	88.7%	0.6	107.2	33.1	F
	Subtotal	1,520	1,374	90.4%	3.8	166.9	39.4	F
SB	Left Turn	10	10	99.0%	0.0	148.9	42.9	F
	Through	630	620	98.4%	0.4	37.5	3.5	D
	Right Turn	200	200	100.1%	0.0	19.4	4.1	B
	Subtotal	840	830	98.8%	0.4	34.6	3.5	C
EB	Left Turn	60	59	97.8%	0.2	54.9	11.9	D
	Through	150	154	102.7%	0.3	51.5	3.5	D
	Right Turn	100	100	100.0%	0.0	16.0	3.0	B
	Subtotal	310	313	100.9%	0.2	40.4	3.2	D
WB	Left Turn	110	111	101.0%	0.1	113.7	51.6	F
	Through	60	50	83.5%	1.3	97.2	44.4	F
	Right Turn	20	19	93.5%	0.3	105.1	56.9	F
	Subtotal	190	180	94.7%	0.7	111.4	49.8	F
Total		2,860	2,697	94.3%	3.1	108.9	19.5	F

Intersection 66

Alma Street/Churchill Street

Signal

Direction	Movement	Volume (vph)		Percent Served	GEH	Total Delay (sec/veh)		
		Demand	Served			Average	Std. Dev.	LOS
NB	Left Turn	160	140	87.7%	1.6	137.9	28.0	F
	Through	790	803	101.7%	0.5	37.1	5.2	D
	Right Turn	58	46	79.5%	1.6	40.7	14.0	D
	Subtotal	1,008	989	98.2%	0.6	48.4	7.2	D
SB	Left Turn	30	28	93.7%	0.4	341.7	36.6	F
	Through	1,508	1,421	94.2%	2.3	178.6	23.8	F
	Right Turn	130	126	97.0%	0.3	170.3	22.9	F
	Subtotal	1,668	1,575	94.4%	2.3	180.7	23.2	F
EB	Left Turn	178	154	86.8%	1.8	176.2	34.3	F
	Through	243	170	69.9%	5.1	177.2	26.5	F
	Right Turn	260	249	95.8%	0.7	151.7	16.7	F
	Subtotal	680	573	84.2%	4.3	165.7	21.0	F
WB	Left Turn	110	103	93.7%	0.7	331.2	81.3	F
	Through	138	120	87.1%	1.6	336.7	76.5	F
	Right Turn	20	17	86.0%	0.6	302.3	96.2	F
	Subtotal	268	240	89.7%	1.7	332.6	78.5	F
Total		3,623	3,377	93.2%	4.2	151.1	10.6	F

Intersection 70

Rengstorff/Central Expressway

Signal

Direction	Movement	Volume (vph)		Percent Served	Total Delay (sec/veh)		
		Demand	Served		Average	Std. Dev.	LOS
NB	Left Turn	190	157	82.8%	153.4	7.2	F
	Through	570	458	80.4%	179.8	9.4	F
	Right Turn	220	187	84.8%	201.9	21.4	F
	Subtotal	980	802	81.9%	180.1	10.6	F
SB	Left Turn	60	62	103.2%	127.3	19.8	F
	Through	350	370	105.6%	144.4	19.4	F
	Right Turn	120	132	109.9%	139.3	42.8	F
	Subtotal	530	564	106.3%	141.2	24.0	F
EB	Left Turn	150	145	96.3%	131.6	27.9	F
	Through	940	933	99.3%	65.1	11.9	E
	Right Turn	120	118	98.3%	45.0	11.9	D
	Subtotal	1,210	1,196	98.8%	70.4	13.3	E
WB	Left Turn	140	123	87.8%	279.1	25.2	F
	Through	1,490	1,330	89.3%	228.6	12.5	F
	Right Turn	270	256	94.7%	147.4	11.5	F
	Subtotal	1,900	1,709	89.9%	220.7	12.7	F
Total		4,620	4,270	92.4%	157.7	6.2	F

Intersection 71

Moffett/Central Expressway

Signal

Direction	Movement	Volume (vph)		Percent Served	Total Delay (sec/veh)		
		Demand	Served		Average	Std. Dev.	LOS
NB	Left Turn	240	240	99.8%	62.7	11.9	E
	Through	320	347	108.4%	64.7	15.1	E
	Right Turn	150	153	101.9%	65.5	14.1	E
	Subtotal	710	739	104.1%	64.2	13.1	E
SB	Left Turn	60	60	100.3%	64.5	7.9	E
	Through	170	176	103.8%	63.6	5.9	E
	Right Turn	300	316	105.2%	44.5	8.6	D
	Subtotal	530	552	104.2%	52.5	6.0	D
EB	Left Turn	320	283	88.3%	329.1	46.9	F
	Through	1,070	952	88.9%	144.5	15.4	F
	Right Turn	180	163	90.3%	95.0	16.7	F
	Subtotal	1,570	1,397	89.0%	176.4	20.6	F
WB	Left Turn	150	102	68.1%	569.0	29.6	F
	Through	1,510	977	64.7%	454.9	12.0	F
	Right Turn	160	105	65.3%	428.2	17.9	F
	Subtotal	1,820	1,183	65.0%	460.4	11.6	F
Total		4,630	3,872	83.6%	233.9	10.1	F

Intersection 70

Rengstorff/Central Expressway

Signal

Direction	Movement	Volume (vph)		Percent Served	Total Delay (sec/veh)		
		Demand	Served		Average	Std. Dev.	LOS
NB	Left Turn	160	151	94.4%	185.7	24.7	F
	Through	420	384	91.5%	207.3	26.8	F
	Right Turn	130	130	100.2%	220.3	27.4	F
	Subtotal	710	665	93.7%	205.4	25.8	F
SB	Left Turn	250	200	80.2%	251.0	13.6	F
	Through	620	495	79.9%	272.7	15.6	F
	Right Turn	80	65	80.8%	268.5	23.2	F
	Subtotal	950	760	80.0%	266.8	11.1	F
EB	Left Turn	180	172	95.6%	133.3	25.8	F
	Through	1,340	1,299	96.9%	62.6	18.0	E
	Right Turn	200	202	100.9%	47.9	19.4	D
	Subtotal	1,720	1,673	97.2%	67.7	18.5	E
WB	Left Turn	190	147	77.2%	665.6	98.7	F
	Through	1,120	896	80.0%	278.5	43.9	F
	Right Turn	130	108	82.7%	135.9	16.5	F
	Subtotal	1,440	1,150	79.9%	330.1	49.0	F
Total		4,820	4,249	88.1%	197.9	19.6	F

Intersection 71

Moffett/Central Expressway

Signal

Direction	Movement	Volume (vph)		Percent Served	Total Delay (sec/veh)		
		Demand	Served		Average	Std. Dev.	LOS
NB	Left Turn	160	134	83.7%	91.2	13.6	F
	Through	450	382	84.8%	101.7	13.1	F
	Right Turn	240	196	81.6%	106.5	16.6	F
	Subtotal	850	712	83.7%	101.1	13.5	F
SB	Left Turn	210	153	72.9%	315.5	38.9	F
	Through	460	365	79.4%	290.2	10.1	F
	Right Turn	100	77	77.3%	269.0	42.1	F
	Subtotal	770	596	77.4%	293.1	13.4	F
EB	Left Turn	270	220	81.5%	216.1	22.8	F
	Through	1,660	1,395	84.1%	151.1	9.5	F
	Right Turn	220	184	83.8%	109.7	12.4	F
	Subtotal	2,150	1,800	83.7%	156.6	10.5	F
WB	Left Turn	270	140	51.7%	668.3	65.7	F
	Through	1,490	802	53.8%	246.3	39.3	F
	Right Turn	120	68	56.4%	204.4	52.5	F
	Subtotal	1,880	1,009	53.7%	320.9	31.9	F
Total		5,650	4,116	72.8%	208.2	8.6	F

VISSIM Post-Processor
Average Results from 10 Runs
Volume and Delay by Movement

Caltrain Electrification
2020 Project
AM Peak Hour

Intersection 77

Mary/Evelyn

Signal

Direction	Movement	Volume (vph)		Percent Served	Total Delay (sec/veh)		
		Demand	Served		Average	Std. Dev.	LOS
NB	Left Turn	80	76	95.1%	60.8	16.6	E
	Through	1,150	1,161	101.0%	67.6	14.0	E
	Right Turn	40	41	103.0%	52.8	13.2	D
	Subtotal	1,270	1,278	100.7%	66.6	13.8	E
SB	Left Turn	70	68	97.6%	68.4	13.0	E
	Through	440	438	99.6%	44.9	7.2	D
	Right Turn	200	204	102.1%	50.9	12.0	D
	Subtotal	710	711	100.1%	49.0	8.4	D
EB	Left Turn	250	246	98.6%	114.3	38.2	F
	Through	140	144	102.5%	24.6	4.8	C
	Right Turn	40	37	93.3%	10.7	5.5	B
	Subtotal	430	427	99.3%	77.0	24.8	E
WB	Left Turn	80	77	95.6%	45.7	6.0	D
	Through	270	274	101.5%	31.0	3.1	C
	Right Turn	220	217	98.5%	21.2	4.0	C
	Subtotal	570	567	99.5%	29.2	2.8	C
Total		2,980	2,984	100.1%	56.7	5.0	E

VISSIM Post-Processor
Average Results from 10 Runs
Volume and Delay by Movement

Catrain Electrification
2020 Project
PM Peak Hour

Intersection 77

Mary/Evelyn

Signal

Direction	Movement	Volume (vph)		Percent Served	Total Delay (sec/veh)		
		Demand	Served		Average	Std. Dev.	LOS
NB	Left Turn	40	43	106.8%	40.1	8.5	D
	Through	480	490	102.0%	46.5	3.3	D
	Right Turn	40	39	96.8%	23.3	6.5	C
	Subtotal	560	571	102.0%	44.3	3.3	D
SB	Left Turn	250	193	77.2%	111.9	9.1	F
	Through	1,680	1,355	80.7%	109.8	7.3	F
	Right Turn	430	350	81.3%	129.4	7.4	F
	Subtotal	2,360	1,898	80.4%	113.7	6.0	F
EB	Left Turn	250	222	88.8%	327.4	46.4	F
	Through	400	354	88.6%	68.6	7.8	E
	Right Turn	110	103	93.7%	65.8	12.9	E
	Subtotal	760	679	89.4%	142.4	19.4	F
WB	Left Turn	60	60	99.8%	47.0	8.3	D
	Through	190	190	99.7%	35.5	4.4	D
	Right Turn	160	159	99.6%	25.9	6.2	C
	Subtotal	410	409	99.7%	33.1	4.4	C
Total		4,090	3,557	87.0%	97.3	3.0	F

2020 Project Mitigated



Intersection 1

4th Street/King Street

Signal

Direction	Movement	Volume (vph)		Percent Served	GEH	Total Delay (sec/veh)		
		Demand	Served			Average	Std. Dev.	LOS
NB	Left Turn	20	9	45.0%	2.9	50.0	23.2	D
	Through	70	76	108.3%	0.7	32.2	13.1	C
	Right Turn	50	39	78.8%	1.6	17.8	6.4	B
	Subtotal	140	124	88.7%	1.4	29.2	10.4	C
SB	Left Turn	140	143	102.3%	0.3	80.7	18.2	F
	Through	510	432	84.7%	3.6	58.7	4.3	E
	Right Turn	310	304	97.9%	0.4	45.0	6.9	D
	Subtotal	960	879	91.5%	2.7	58.0	4.0	E
EB	Left Turn	110	87	79.5%	2.3	401.5	26.7	F
	Through	1,590	1,310	82.4%	7.3	227.0	11.8	F
	Right Turn	10	9	87.0%	0.4	116.5	43.7	F
	Subtotal	1,710	1,406	82.2%	7.7	236.9	13.1	F
WB	Left Turn	30	49	164.7%	3.1	95.6	23.0	F
	Through	990	745	75.3%	8.3	51.5	4.5	D
	Right Turn	20	46	227.5%	4.5	41.7	10.3	D
	Subtotal	1,040	840	80.8%	6.5	53.8	4.6	D
Total		3,850	3,249	84.4%	10.1	134.8	2.8	F

Intersection 2

4th Street/Townsend Street

Signal

Direction	Movement	Volume (vph)		Percent Served	GEH	Total Delay (sec/veh)		
		Demand	Served			Average	Std. Dev.	LOS
NB	Left Turn							
	Through	30	30	100.0%	0.0	52.0	13.1	D
	Right Turn	170	174	102.3%	0.3	27.6	8.5	C
	Subtotal	200	204	102.0%	0.3	31.0	9.2	C
SB	Left Turn							
	Through	580	598	103.2%	0.8	104.1	33.0	F
	Right Turn	80	72	90.1%	0.9	148.0	56.3	F
	Subtotal	660	670	101.6%	0.4	109.6	35.0	F
EB	Left Turn							
	Through	460	477	103.7%	0.8	134.9	72.3	F
	Right Turn	170	143	84.4%	2.1	381.4	132.5	F
	Subtotal	630	620	98.5%	0.4	189.1	82.1	F
WB	Left Turn	210	181	86.1%	2.1	119.3	45.0	F
	Through	220	228	103.7%	0.5	20.3	7.5	C
	Right Turn							
	Subtotal	430	409	95.1%	1.0	60.4	22.8	E
Total		1,920	1,904	99.2%	0.4	113.4	24.3	F

Intersection 5 7th Street/16th Street

Signal

Direction	Movement	Volume (vph)		Percent Served	GEH	Total Delay (sec/veh)		
		Demand	Served			Average	Std. Dev.	LOS
NB	Left Turn	170	153	89.7%	1.4	139.0	35.5	F
	Through	390	358	91.8%	1.6	137.1	38.0	F
	Right Turn	110	100	90.5%	1.0	108.5	33.3	F
	Subtotal	670	610	91.1%	2.4	133.1	35.9	F
SB	Left Turn	120	121	100.5%	0.1	149.3	32.1	F
	Through	100	99	99.4%	0.1	123.8	42.5	F
	Right Turn	40	39	97.3%	0.2	103.4	35.4	F
	Subtotal	260	259	99.6%	0.1	131.5	23.0	F
EB	Left Turn	40	37	91.8%	0.5	108.8	40.4	F
	Through	390	383	98.2%	0.4	167.9	43.9	F
	Right Turn	110	110	100.4%	0.0	150.8	35.3	F
	Subtotal	540	530	98.1%	0.4	160.5	41.8	F
WB	Left Turn	80	76	94.5%	0.5	86.7	13.8	F
	Through	220	213	96.6%	0.5	78.7	15.7	E
	Right Turn	170	163	96.0%	0.5	37.9	9.5	D
	Subtotal	470	451	96.0%	0.9	64.6	8.5	E
Total		1,940	1,850	95.4%	2.1	121.7	14.9	F

Intersection 6 Owens Street/16th Street

Signal

Direction	Movement	Volume (vph)		Percent Served	GEH	Total Delay (sec/veh)		
		Demand	Served			Average	Std. Dev.	LOS
NB	Left Turn							
	Through							
	Right Turn							
	Subtotal							
SB	Left Turn	60	62	102.7%	0.2	18.9	2.5	B
	Through							
	Right Turn	110	107	97.5%	0.3	6.4	0.8	A
	Subtotal	170	169	99.3%	0.1	11.1	1.3	B
EB	Left Turn	250	243	97.0%	0.5	22.4	5.8	C
	Through	370	367	99.2%	0.2	4.1	1.0	A
	Right Turn							
	Subtotal	620	610	98.3%	0.4	11.7	2.7	B
WB	Left Turn							
	Through	340	337	99.1%	0.2	12.7	2.4	B
	Right Turn	120	121	101.1%	0.1	9.7	2.0	A
	Subtotal	460	458	99.6%	0.1	12.0	2.2	B
Total		1,250	1,237	98.9%	0.4	11.7	1.7	B

VISSIM Post-Processor
Average Results from 10 Runs
Volume and Delay by Movement

Caltrain Electrification Existing
2020 Project Mitigated
AM Peak Hour

Intersection 18

California/Broadway

Signal

Direction	Movement	Volume (vph)		Percent Served	Total Delay (sec/veh)		
		Demand	Served		Average	Std. Dev.	LOS
NB	Left Turn	27	26	95.9%	90.2	20.6	F
	Through	277	283	102.2%	65.0	6.2	E
	Right Turn	490	483	98.5%	17.7	3.8	B
	Subtotal	794	792	99.7%	38.3	3.3	D
SB	Left Turn	436	429	98.5%	140.6	9.2	F
	Through	339	327	96.6%	127.9	11.3	F
	Right Turn	27	23	84.1%	127.2	20.6	F
	Subtotal	802	780	97.2%	134.9	8.5	F
EB	Left Turn	8	7	86.3%	46.4	41.1	D
	Through	379	380	100.2%	48.9	4.8	D
	Right Turn	31	32	101.6%	26.1	11.5	C
	Subtotal	418	418	100.0%	47.1	4.6	D
WB	Left Turn	241	238	98.7%	18.6	1.7	B
	Through	277	269	97.1%	8.3	0.9	A
	Right Turn	256	261	102.0%	1.4	0.5	A
	Subtotal	774	768	99.2%	8.8	0.8	A
Total		2,788	2,757	98.9%	60.0	1.8	E

Intersection 19

Carolan/Broadway

Signal

Direction	Movement	Volume (vph)		Percent Served	Total Delay (sec/veh)		
		Demand	Served		Average	Std. Dev.	LOS
NB	Left Turn	97	96	98.8%	111.3	23.2	F
	Through	1	0	0.0%			
	Right Turn	397	398	100.4%	18.4	5.3	B
	Subtotal	495	494	99.8%	36.1	6.2	D
SB	Left Turn						
	Through						
	Right Turn						
	Subtotal						
EB	Left Turn	1	1	70.0%	7.2	16.1	A
	Through	1,144	1,130	98.8%	1.4	0.2	A
	Right Turn	160	160	100.3%	2.1	1.2	A
	Subtotal	1,305	1,291	98.9%	1.5	0.2	A
WB	Left Turn	103	108	104.4%	66.4	8.7	E
	Through	676	671	99.3%	24.1	4.6	C
	Right Turn						
	Subtotal	779	779	99.9%	29.3	4.2	C
Total		2,579	2,564	99.4%	16.6	1.9	B

VISSIM Post-Processor
Average Results from 10 Runs
Volume and Delay by Movement

Caltrain Electrification
2020 Project Mitigated
PM Peak Hour

Intersection 18

California/Broadway

Signal

Direction	Movement	Volume (vph)		Percent Served	Total Delay (sec/veh)		
		Demand	Served		Average	Std. Dev.	LOS
NB	Left Turn	31	30	96.8%	77.5	10.9	E
	Through	339	340	100.1%	60.0	7.0	E
	Right Turn	337	336	99.8%	10.4	2.8	B
	Subtotal	707	706	99.8%	37.8	4.8	D
SB	Left Turn	397	385	96.9%	135.9	20.9	F
	Through	334	323	96.6%	132.7	27.2	F
	Right Turn	38	33	86.8%	122.7	33.3	F
	Subtotal	769	740	96.3%	134.1	23.7	F
EB	Left Turn	11	10	90.0%	59.6	40.7	E
	Through	286	288	100.7%	58.4	5.7	E
	Right Turn	46	46	100.4%	42.0	18.9	D
	Subtotal	343	344	100.3%	56.8	5.6	E
WB	Left Turn	357	315	88.3%	14.4	0.9	B
	Through	477	432	90.6%	6.5	1.1	A
	Right Turn	353	330	93.3%	2.0	0.6	A
	Subtotal	1,187	1,077	90.7%	7.3	0.4	A
Total		3,006	2,867	95.4%	52.5	6.0	D

Intersection 19

Carolan/Broadway

Signal

Direction	Movement	Volume (vph)		Percent Served	Total Delay (sec/veh)		
		Demand	Served		Average	Std. Dev.	LOS
NB	Left Turn	86	87	100.7%	133.9	46.7	F
	Through	1	1	120.0%	29.4	93.1	C
	Right Turn	311	311	100.0%	10.5	2.8	B
	Subtotal	398	399	100.2%	37.5	10.4	D
SB	Left Turn						
	Through						
	Right Turn						
	Subtotal						
EB	Left Turn	1	1	60.0%	2.1	6.6	A
	Through	915	906	99.0%	1.9	0.7	A
	Right Turn	104	102	98.4%	2.1	0.9	A
	Subtotal	1,020	1,009	98.9%	1.9	0.6	A
WB	Left Turn	195	167	85.5%	161.7	31.3	F
	Through	1,101	989	89.8%	70.4	22.2	E
	Right Turn	1	1	80.0%	19.3	36.0	B
	Subtotal	1,297	1,157	89.2%	83.6	20.6	F
Total		2,715	2,564	94.4%	42.1	9.7	D

Intersection 45

El Camino Real/Whipple Road

Signal

Direction	Movement	Volume (vph)		Percent Served	GEH	Total Delay (sec/veh)		
		Demand	Served			Average	Std. Dev.	LOS
NB	Left Turn	60	60	100.0%	0.0	83.3	17.2	F
	Through	890	885	99.4%	0.2	41.3	8.6	D
	Right Turn	500	509	101.9%	0.4	19.0	7.8	B
	Subtotal	1,450	1,454	100.3%	0.1	35.9	8.3	D
SB	Left Turn	300	294	98.1%	0.3	102.8	9.4	F
	Through	1,080	1,068	98.9%	0.4	42.8	5.7	D
	Right Turn	70	69	98.6%	0.1	37.1	5.3	D
	Subtotal	1,450	1,431	98.7%	0.5	55.1	5.3	E
EB	Left Turn	110	110	99.7%	0.0	72.6	12.9	E
	Through	460	445	96.7%	0.7	72.7	8.9	E
	Right Turn	50	50	100.2%	0.0	75.3	18.4	E
	Subtotal	620	605	97.5%	0.6	73.0	10.0	E
WB	Left Turn	290	292	100.7%	0.1	42.5	7.2	D
	Through	290	294	101.5%	0.3	40.4	6.4	D
	Right Turn	280	279	99.6%	0.1	8.1	1.5	A
	Subtotal	860	865	100.6%	0.2	31.0	5.1	C
Total		4,380	4,355	99.4%	0.4	46.5	4.5	D

Intersection 62

Palo Alto/Alma

Side-street Stop

Direction	Movement	Volume (vph)		Percent Served	GEH	Total Delay (sec/veh)		
		Demand	Served			Average	Std. Dev.	LOS
NB	Left Turn							
	Through							
	Right Turn							
	Subtotal							
SB	Left Turn	10	9	94.0%	0.2	9.2	10.2	A
	Through							
	Right Turn	30	28	93.3%	0.4	16.4	7.4	C
	Subtotal	40	37	93.5%	0.4	13.7	6.3	B
EB	Left Turn							
	Through	500	502	100.4%	0.1	14.1	2.9	B
	Right Turn							
	Subtotal	500	502	100.4%	0.1	14.1	2.9	B
WB	Left Turn							
	Through	530	527	99.5%	0.1	11.3	2.8	B
	Right Turn	20	21	102.5%	0.1	10.6	15.5	B
	Subtotal	550	548	99.6%	0.1	11.1	2.8	B
Total		1,090	1,087	99.7%	0.1	12.6	2.4	B

VISSIM Post-Processor
Average Results from 10 Runs
Volume and Delay by Movement

Caltrain Electrification
2020 Project Mitigated
AM Peak Hour

Intersection 64

El Camino Real/Sand Hill-Palo Alto

Signal

Direction	Movement	Volume (vph)		Percent Served	GEH	Total Delay (sec/veh)		
		Demand	Served			Average	Std. Dev.	LOS
NB	Left Turn	140	140	99.9%	0.0	80.9	17.5	F
	Through	570	571	100.2%	0.1	49.2	2.8	D
	Right Turn	30	29	95.3%	0.3	30.6	11.1	C
	Subtotal	740	740	99.9%	0.0	54.6	4.7	D
SB	Left Turn	470	474	100.7%	0.2	81.9	8.6	F
	Through	1,330	1,323	99.5%	0.2	34.1	2.9	C
	Right Turn	690	691	100.2%	0.1	21.1	4.4	C
	Subtotal	2,490	2,488	99.9%	0.0	39.7	3.0	D
EB	Left Turn	290	293	101.1%	0.2	57.8	4.1	E
	Through							
	Right Turn	240	235	97.9%	0.3	10.7	2.0	B
	Subtotal	530	528	99.6%	0.1	37.8	3.0	D
WB	Left Turn							
	Through							
	Right Turn	560	556	99.2%	0.2	4.2	0.4	A
	Subtotal	560	556	99.2%	0.2	4.2	0.4	A
Total		4,320	4,312	99.8%	0.1	37.7	2.4	D

Intersection 63

Alma Street/Meadow Drive

Signal

Direction	Movement	Volume (vph)		Percent Served	GEH	Total Delay (sec/veh)		
		Demand	Served			Average	Std. Dev.	LOS
NB	Left Turn	130	120	92.3%	0.9	169.6	24.5	F
	Through	1,420	1,290	90.9%	3.5	113.6	15.0	F
	Right Turn	60	52	86.3%	1.1	108.3	16.3	F
	Subtotal	1,610	1,462	90.8%	3.8	118.1	15.7	F
SB	Left Turn	60	62	103.8%	0.3	182.9	42.1	F
	Through	680	689	101.4%	0.4	42.5	14.9	D
	Right Turn	160	164	102.3%	0.3	20.7	10.0	C
	Subtotal	900	915	101.7%	0.5	46.0	17.2	D
EB	Left Turn	180	180	100.1%	0.0	129.8	5.5	F
	Through	190	186	97.9%	0.3	130.9	5.0	F
	Right Turn	130	125	96.2%	0.4	126.7	6.1	F
	Subtotal	500	491	98.3%	0.4	129.4	2.5	F
WB	Left Turn	130	127	97.7%	0.3	227.3	17.8	F
	Through	240	232	96.8%	0.5	227.2	24.3	F
	Right Turn	90	83	92.7%	0.7	212.3	22.8	F
	Subtotal	460	443	96.2%	0.8	224.5	19.9	F
Total		3,470	3,311	95.4%	2.7	114.1	9.3	F

Intersection 68

Alma Street/Charleston Road

Signal

Direction	Movement	Volume (vph)		Percent Served	GEH	Total Delay (sec/veh)		
		Demand	Served			Average	Std. Dev.	LOS
NB	Left Turn	350	309	88.3%	2.2	492.4	65.9	F
	Through	1,370	1,197	87.4%	4.8	249.2	28.3	F
	Right Turn	50	42	83.0%	1.3	243.1	39.7	F
	Subtotal	1,770	1,548	87.5%	5.4	305.1	36.5	F
SB	Left Turn	80	78	97.9%	0.2	260.8	94.9	F
	Through	840	828	98.6%	0.4	49.8	12.0	D
	Right Turn	80	79	98.4%	0.1	21.8	5.7	C
	Subtotal	1,000	985	98.5%	0.5	68.7	21.8	E
EB	Left Turn	130	128	98.6%	0.2	50.6	6.0	D
	Through	430	429	99.9%	0.0	52.9	2.7	D
	Right Turn	210	207	98.3%	0.2	47.6	5.5	D
	Subtotal	770	764	99.2%	0.2	51.1	2.0	D
WB	Left Turn	80	84	105.0%	0.4	98.1	50.9	F
	Through	280	292	104.2%	0.7	104.4	48.7	F
	Right Turn	110	109	99.4%	0.1	101.8	58.7	F
	Subtotal	470	485	103.2%	0.7	102.9	50.9	F
Total		4,010	3,782	94.3%	3.6	166.3	12.3	F

Intersection 67

Park Ave/Meadow Drive

Side-street Stop

Direction	Movement	Volume (vph)		Percent Served	GEH	Total Delay (sec/veh)		
		Demand	Served			Average	Std. Dev.	LOS
NB	Left Turn	10	9	88.0%	0.4	165.8	173.4	F
	Through							
	Right Turn	30	28	93.3%	0.4	319.0	202.5	F
	Subtotal	40	37	92.0%	0.5	275.2	183.6	F
SB	Left Turn							
	Through							
	Right Turn							
	Subtotal							
EB	Left Turn							
	Through	470	468	99.5%	0.1	79.8	38.0	F
	Right Turn	10	9	90.0%	0.3	68.3	40.2	F
	Subtotal	480	477	99.3%	0.2	79.5	37.8	F
WB	Left Turn							
	Through	440	430	97.7%	0.5	1.0	0.4	A
	Right Turn	90	86	95.1%	0.5	2.2	0.6	A
	Subtotal	530	516	97.3%	0.6	1.3	0.2	A
Total		1,050	1,029	98.0%	0.7	48.9	22.1	E

Intersection 68

Alma/Charleston Road

Side-street Stop

Direction	Movement	Volume (vph)		Percent Served	GEH	Total Delay (sec/veh)		
		Demand	Served			Average	Std. Dev.	LOS
NB	Left Turn	25	24	95.6%	0.2	23.1	12.4	C
	Through	10	9	88.0%	0.4	20.1	14.5	C
	Right Turn	25	24	96.8%	0.2	37.4	20.9	E
	Subtotal	60	57	94.8%	0.4	29.9	14.4	D
SB	Left Turn	25	25	101.6%	0.1	28.4	9.5	D
	Through	10	10	99.0%	0.0	24.8	30.0	C
	Right Turn	25	22	86.0%	0.7	12.5	15.8	B
	Subtotal	60	57	94.7%	0.4	21.5	11.0	C
EB	Left Turn	25	25	99.6%	0.0	11.5	6.8	B
	Through	720	713	99.0%	0.3	14.0	2.9	B
	Right Turn	25	25	98.0%	0.1	10.9	7.6	B
	Subtotal	770	762	99.0%	0.3	13.9	2.9	B
WB	Left Turn	25	23	90.4%	0.5	3.5	3.7	A
	Through	660	633	95.9%	1.1	0.9	0.6	A
	Right Turn	25	24	96.8%	0.2	2.3	0.8	A
	Subtotal	710	680	95.7%	1.1	1.0	0.6	A
Total		1,600	1,556	97.2%	1.1	9.4	1.7	A

Intersectio 70

Rengstorff/Central Expressway

Signal

Direction	Movement	Volume (vph)		Percent Served	Total Delay (sec/veh)		
		Demand	Served		Average	Std. Dev.	LOS
NB	Left Turn	160	151	94.1%	169.0	40.5	F
	Through	420	387	92.2%	185.7	47.6	F
	Right Turn	130	132	101.4%	201.8	54.6	F
	Subtotal	710	670	94.3%	185.0	46.8	F
SB	Left Turn	250	198	79.0%	252.4	10.4	F
	Through	620	501	80.7%	266.7	16.4	F
	Right Turn	80	64	80.4%	273.6	29.5	F
	Subtotal	950	762	80.3%	263.8	10.6	F
EB	Left Turn	180	172	95.6%	82.7	7.8	F
	Through	1,340	1,314	98.0%	33.1	2.1	C
	Right Turn	200	200	100.2%	18.1	3.2	B
	Subtotal	1,720	1,686	98.0%	36.0	2.2	D
WB	Left Turn	190	143	75.3%	844.1	182.2	F
	Through	1,120	1,064	95.0%	122.2	117.7	F
	Right Turn	130	128	98.4%	50.2	72.1	D
	Subtotal	1,440	1,335	92.7%	218.0	143.7	F
Total		4,820	4,453	92.4%	154.8	6.9	F

Intersection 71

Moffett/Central Expressway

Signal

Direction	Movement	Volume (vph)		Percent Served	Total Delay (sec/veh)		
		Demand	Served		Average	Std. Dev.	LOS
NB	Left Turn	160	131	81.8%	92.1	13.1	F
	Through	450	379	84.2%	107.2	15.9	F
	Right Turn	240	196	81.8%	112.6	20.4	F
	Subtotal	850	706	83.0%	106.2	15.6	F
SB	Left Turn	210	152	72.5%	316.5	32.7	F
	Through	460	360	78.3%	293.1	11.7	F
	Right Turn	100	78	78.2%	260.1	31.2	F
	Subtotal	770	591	76.7%	294.1	12.7	F
EB	Left Turn	270	219	80.9%	213.9	20.1	F
	Through	1,660	1,399	84.3%	152.5	10.4	F
	Right Turn	220	184	83.8%	113.4	11.6	F
	Subtotal	2,150	1,802	83.8%	157.6	11.3	F
WB	Left Turn	270	140	51.7%	676.2	66.4	F
	Through	1,490	819	55.0%	234.2	38.7	F
	Right Turn	120	67	56.2%	186.9	45.9	F
	Subtotal	1,880	1,026	54.6%	309.5	27.2	F
Total		5,650	4,124	73.0%	208.1	9.1	F

2040 No Project



Intersection 1

4th Street/King Street

Signal

Direction	Movement	Volume (vph)		Percent Served	GEH	Total Delay (sec/veh)		
		Demand	Served			Average	Std. Dev.	LOS
NB	Left Turn	10	10	104.0%	0.1	58.8	39.3	E
	Through	60	80	133.0%	2.4	27.6	5.1	C
	Right Turn	40	39	96.3%	0.2	12.8	5.9	B
	Subtotal	110	129	117.0%	1.7	25.6	4.8	C
SB	Left Turn	140	138	98.6%	0.2	94.8	13.4	F
	Through	490	425	86.7%	3.0	57.5	5.2	E
	Right Turn	300	248	82.8%	3.1	41.4	5.8	D
	Subtotal	930	811	87.2%	4.0	59.2	4.0	E
EB	Left Turn	100	78	77.9%	2.3	380.6	27.5	F
	Through	1,800	1,426	79.2%	9.3	200.4	9.0	F
	Right Turn	10	8	75.0%	0.8	102.2	30.8	F
	Subtotal	1,910	1,511	79.1%	9.6	208.6	9.6	F
WB	Left Turn	40	44	109.0%	0.6	93.6	35.3	F
	Through	860	862	100.2%	0.1	55.3	10.7	E
	Right Turn	30	53	177.7%	3.6	43.9	12.8	D
	Subtotal	930	959	103.1%	0.9	56.6	10.4	E
Total		3,880	3,410	87.9%	7.8	123.6	3.5	F

Intersection 2

4th Street/Townsend Street

Signal

Direction	Movement	Volume (vph)		Percent Served	GEH	Total Delay (sec/veh)		
		Demand	Served			Average	Std. Dev.	LOS
NB	Left Turn							
	Through	30	27	89.0%	0.6	34.6	15.5	C
	Right Turn	160	175	109.1%	1.1	15.1	4.7	B
	Subtotal	190	201	105.9%	0.8	17.7	5.5	B
SB	Left Turn							
	Through	580	551	95.0%	1.2	207.2	32.0	F
	Right Turn	80	61	76.4%	2.3	302.8	55.3	F
	Subtotal	660	612	92.7%	1.9	216.9	33.7	F
EB	Left Turn							
	Through	400	421	105.2%	1.0	174.8	95.4	F
	Right Turn	175	156	89.4%	1.4	428.5	195.8	F
	Subtotal	575	577	100.4%	0.1	254.4	126.1	F
WB	Left Turn	175	169	96.8%	0.4	151.4	100.9	F
	Through	220	229	104.0%	0.6	24.2	25.9	C
	Right Turn							
	Subtotal	395	398	100.8%	0.2	80.8	60.1	F
Total		1,820	1,789	98.3%	0.7	175.1	39.0	F

Intersection 1

4th Street/King Street

Signal

Direction	Movement	Volume (vph)		Percent Served	GEH	Total Delay (sec/veh)		
		Demand	Served			Average	Std. Dev.	LOS
NB	Left Turn	20	19	97.0%	0.1	55.9	16.8	E
	Through	70	121	172.7%	5.2	30.1	5.6	C
	Right Turn	50	60	119.4%	1.3	16.6	5.3	B
	Subtotal	140	200	142.9%	4.6	29.3	4.7	C
SB	Left Turn	150	124	82.8%	2.2	95.2	17.0	F
	Through	300	267	89.1%	1.9	62.9	8.1	E
	Right Turn	590	495	83.8%	4.1	43.1	8.5	D
	Subtotal	1,040	886	85.2%	5.0	57.0	7.2	E
EB	Left Turn	160	124	77.3%	3.1	398.6	37.1	F
	Through	1,430	1,181	82.6%	6.9	223.4	18.8	F
	Right Turn	20	14	70.5%	1.4	118.1	28.5	F
	Subtotal	1,610	1,319	81.9%	7.6	239.2	18.9	F
WB	Left Turn	30	24	80.0%	1.2	353.3	38.1	F
	Through	1,000	886	88.6%	3.7	336.5	27.2	F
	Right Turn	20	51	255.5%	5.2	145.9	57.3	F
	Subtotal	1,050	961	91.5%	2.8	327.5	26.8	F
Total		3,840	3,366	87.6%	7.9	201.1	5.7	F

Intersection 2

4th Street/Townsend Street

Signal

Direction	Movement	Volume (vph)		Percent Served	GEH	Total Delay (sec/veh)		
		Demand	Served			Average	Std. Dev.	LOS
NB	Left Turn							
	Through	30	25	81.7%	1.1	32.4	16.2	C
	Right Turn	220	218	98.9%	0.2	18.2	3.1	B
	Subtotal	250	242	96.8%	0.5	19.2	3.8	B
SB	Left Turn							
	Through	630	579	91.9%	2.1	319.0	39.4	F
	Right Turn	90	74	82.2%	1.8	452.5	60.4	F
	Subtotal	720	653	90.7%	2.6	335.7	38.0	F
EB	Left Turn							
	Through	590	319	54.1%	12.7	34.4	6.6	C
	Right Turn	130	134	103.0%	0.3	57.9	18.2	E
	Subtotal	720	453	62.9%	11.0	41.1	8.3	D
WB	Left Turn	280	248	88.5%	2.0	306.1	60.9	F
	Through	310	309	99.8%	0.0	95.9	41.9	F
	Right Turn							
	Subtotal	590	557	94.5%	1.4	194.0	50.9	F
Total		2,280	1,905	83.6%	8.2	186.1	21.3	F

VISSIM Post-Processor
Average Results from 10 Runs
Volume and Delay by Movement

Caltrain Electrification
2040 No Project
AM Peak Hour

Intersection 18

California/Broadway

Signal

Direction	Movement	Volume (vph)		Percent Served	Total Delay (sec/veh)		
		Demand	Served		Average	Std. Dev.	LOS
NB	Left Turn	70	67	95.6%	77.3	16.3	E
	Through	300	301	100.2%	61.2	8.4	E
	Right Turn	560	563	100.5%	42.3	18.3	D
	Subtotal	930	930	100.0%	50.3	11.8	D
SB	Left Turn	600	502	83.6%	166.4	27.0	F
	Through	350	287	82.0%	146.9	19.8	F
	Right Turn	30	25	83.0%	131.9	30.2	F
	Subtotal	980	814	83.0%	158.3	23.6	F
EB	Left Turn	10	6	62.0%	111.4	106.4	F
	Through	380	286	75.3%	235.9	26.0	F
	Right Turn	200	144	72.2%	245.1	48.8	F
	Subtotal	590	437	74.0%	235.2	30.0	F
WB	Left Turn	330	271	82.2%	13.8	2.0	B
	Through	280	240	85.8%	6.5	1.4	A
	Right Turn	360	336	93.2%	0.9	0.5	A
	Subtotal	970	847	87.3%	6.7	0.5	A
Total		3,470	3,028	87.3%	89.0	5.7	F

Intersection 19

Carolan/Broadway

Signal

Direction	Movement	Volume (vph)		Percent Served	Total Delay (sec/veh)		
		Demand	Served		Average	Std. Dev.	LOS
NB	Left Turn	230	224	97.4%	191.4	45.2	F
	Through	1	10	950.0%	187.2	98.8	F
	Right Turn	570	550	96.5%	103.3	13.4	F
	Subtotal	801	784	97.8%	131.0	23.2	F
SB	Left Turn						
	Through						
	Right Turn						
	Subtotal						
EB	Left Turn	10	8	84.0%	18.0	23.0	B
	Through	1,180	1,032	87.5%	3.2	0.6	A
	Right Turn	350	310	88.6%	3.4	0.8	A
	Subtotal	1,540	1,351	87.7%	3.4	0.5	A
WB	Left Turn	280	217	77.6%	325.4	28.2	F
	Through	740	620	83.8%	56.6	15.9	E
	Right Turn	10	8	82.0%	37.3	29.1	D
	Subtotal	1,030	846	82.1%	132.9	19.7	F
Total		3,371	2,980	88.4%	72.9	3.7	E

VISSIM Post-Processor
Average Results from 10 Runs
Volume and Delay by Movement

Caltrain Electrification
2040 No Project
PM Peak Hour

Intersection 18

California/Broadway

Signal

Direction	Movement	Volume (vph)		Percent Served	Total Delay (sec/veh)		
		Demand	Served		Average	Std. Dev.	LOS
NB	Left Turn	40	40	99.8%	70.7	9.5	E
	Through	500	495	98.9%	66.0	6.1	E
	Right Turn	340	346	101.8%	12.8	2.9	B
	Subtotal	880	881	100.1%	45.2	4.1	D
SB	Left Turn	410	259	63.1%	159.4	11.9	F
	Through	530	338	63.7%	155.6	7.0	F
	Right Turn	40	25	61.8%	147.2	39.7	F
	Subtotal	980	621	63.4%	156.7	7.3	F
EB	Left Turn	20	23	112.5%	81.4	30.9	F
	Through	290	289	99.6%	71.4	20.5	E
	Right Turn	50	48	95.8%	50.6	21.4	D
	Subtotal	360	359	99.8%	69.2	19.6	E
WB	Left Turn	360	299	83.1%	17.0	1.5	B
	Through	530	447	84.4%	7.5	1.4	A
	Right Turn	420	357	84.9%	4.4	2.4	A
	Subtotal	1,310	1,103	84.2%	8.8	1.3	A
Total		3,530	2,964	84.0%	60.8	2.0	E

Intersection 19

Carolan/Broadway

Signal

Direction	Movement	Volume (vph)		Percent Served	Total Delay (sec/veh)		
		Demand	Served		Average	Std. Dev.	LOS
NB	Left Turn	160	161	100.6%	203.7	102.1	F
	Through	10	10	95.0%	180.7	109.0	F
	Right Turn	520	517	99.4%	53.5	26.0	D
	Subtotal	690	688	99.6%	92.0	40.0	F
SB	Left Turn						
	Through						
	Right Turn						
	Subtotal						
EB	Left Turn	10	9	89.0%	25.5	16.0	C
	Through	920	786	85.5%	2.4	0.4	A
	Right Turn	110	98	89.2%	2.6	1.4	A
	Subtotal	1,040	893	85.9%	2.8	0.6	A
WB	Left Turn	390	316	81.0%	186.8	25.3	F
	Through	1,150	943	82.0%	69.2	13.6	E
	Right Turn	10	8	75.0%	66.8	52.7	E
	Subtotal	1,550	1,267	81.7%	99.3	9.6	F
Total		3,280	2,848	86.8%	67.2	11.3	E

Intersection 45 El Camino Real/Whipple Road Signal

Direction	Movement	Volume (vph)		Percent Served	Total Delay (sec/veh)		
		Demand	Served		Average	Std. Dev.	LOS
NB	Left Turn	70	68	97.4%	101.2	14.2	F
	Through	1,060	1,036	97.8%	73.8	8.2	E
	Right Turn	580	581	100.1%	59.0	8.8	E
	Subtotal	1,710	1,685	98.6%	69.9	8.2	E
SB	Left Turn	300	300	100.0%	114.4	12.6	F
	Through	1,110	1,103	99.3%	36.5	9.0	D
	Right Turn	100	104	103.7%	32.8	11.0	C
	Subtotal	1,510	1,507	99.8%	51.7	8.1	D
EB	Left Turn	150	142	94.7%	206.5	31.7	F
	Through	460	424	92.1%	211.8	32.3	F
	Right Turn	70	64	91.1%	208.6	40.6	F
	Subtotal	680	630	92.6%	210.4	32.3	F
WB	Left Turn	290	290	100.1%	31.1	5.6	C
	Through	290	286	98.8%	30.4	2.8	C
	Right Turn	290	289	99.8%	12.6	1.8	B
	Subtotal	870	866	99.6%	25.3	2.0	C
Total		4,770	4,688	98.3%	71.7	6.8	E

Intersection 62 Palo Alto/Alma Side-street Stop

Direction	Movement	Volume (vph)		Percent Served	Total Delay (sec/veh)		
		Demand	Served		Average	Std. Dev.	LOS
NB	Left Turn						
	Through						
	Right Turn						
	Subtotal						
SB	Left Turn	210	207	98.7%	39.2	18.0	E
	Through						
	Right Turn	20	20	97.5%	44.0	36.5	E
	Subtotal	230	227	98.6%	39.5	19.0	E
EB	Left Turn						
	Through	570	548	96.2%	4.3	1.5	A
	Right Turn						
	Subtotal	570	548	96.2%	4.3	1.5	A
WB	Left Turn						
	Through	690	685	99.3%	6.4	1.8	A
	Right Turn	20	22	111.0%	3.6	3.6	A
	Subtotal	710	707	99.6%	6.3	1.8	A
Total		1,510	1,483	98.2%	13.3	2.4	B

Intersection 64 El Camino Real/Sand Hill-Palo Alto Signal

Direction	Movement	Volume (vph)		Percent Served	Total Delay (sec/veh)		
		Demand	Served		Average	Std. Dev.	LOS
NB	Left Turn	140	139	99.3%	76.5	12.7	E
	Through	1,170	1,172	100.2%	63.4	8.9	E
	Right Turn	40	38	96.0%	31.6	13.3	C
	Subtotal	1,350	1,350	100.0%	63.9	8.1	E
SB	Left Turn	530	511	96.4%	249.3	68.5	F
	Through	1,660	1,661	100.1%	41.3	6.1	D
	Right Turn	540	537	99.4%	33.6	8.7	C
	Subtotal	2,730	2,709	99.2%	79.5	17.1	E
EB	Left Turn	280	280	99.9%	59.9	5.8	E
	Through						
	Right Turn	230	228	99.0%	12.4	2.5	B
	Subtotal	510	508	99.5%	38.7	4.3	D
WB	Left Turn						
	Through						
	Right Turn	710	704	99.2%	6.3	1.6	A
	Subtotal	710	704	99.2%	6.3	1.6	A
Total		5,300	5,270	99.4%	62.1	7.7	E

Intersection 45 El Camino Real/Whipple Road Signal

Direction	Movement	Volume (vph)		Percent Served	Total Delay (sec/veh)		
		Demand	Served		Average	Std. Dev.	LOS
NB	Left Turn	80	75	94.3%	132.6	17.8	F
	Through	1,390	1,359	97.8%	79.2	4.9	E
	Right Turn	260	246	94.8%	61.6	8.0	E
	Subtotal	1,730	1,681	97.2%	78.8	5.2	E
SB	Left Turn	470	447	95.1%	150.1	22.0	F
	Through	1,290	1,251	97.0%	57.1	11.2	E
	Right Turn	100	98	98.3%	55.4	14.6	E
	Subtotal	1,860	1,797	96.6%	80.7	14.2	F
EB	Left Turn	170	147	86.4%	208.3	19.8	F
	Through	290	260	89.7%	210.7	23.5	F
	Right Turn	100	91	91.2%	207.5	23.7	F
	Subtotal	560	498	89.0%	209.4	20.5	F
WB	Left Turn	410	414	101.1%	52.8	6.8	D
	Through	480	470	97.9%	42.4	4.5	D
	Right Turn	320	318	99.4%	16.2	2.8	B
	Subtotal	1,210	1,203	99.4%	39.2	4.0	D
Total		5,360	5,179	96.6%	85.0	5.6	F

Intersection 62 Palo Alto/Alma Side-street Stop

Direction	Movement	Volume (vph)		Percent Served	Total Delay (sec/veh)		
		Demand	Served		Average	Std. Dev.	LOS
NB	Left Turn						
	Through						
	Right Turn						
	Subtotal						
SB	Left Turn	10	9	93.0%	18.4	16.7	C
	Through						
	Right Turn	60	60	99.5%	25.9	5.8	D
	Subtotal	70	69	98.6%	24.3	5.9	C
EB	Left Turn						
	Through	660	608	92.2%	5.5	1.4	A
	Right Turn						
	Subtotal	660	608	92.2%	5.5	1.4	A
WB	Left Turn						
	Through	740	743	100.5%	8.6	1.4	A
	Right Turn	140	135	96.6%	6.9	1.4	A
	Subtotal	880	879	99.8%	8.3	1.1	A
Total		1,610	1,556	96.6%	7.9	0.8	A

Intersection 64 El Camino Real/Sand Hill-Palo Alto Signal

Direction	Movement	Volume (vph)		Percent Served	Total Delay (sec/veh)		
		Demand	Served		Average	Std. Dev.	LOS
NB	Left Turn	150	133	88.7%	227.8	10.2	F
	Through	1,680	1,437	85.5%	235.7	7.5	F
	Right Turn	180	149	82.8%	195.0	8.5	F
	Subtotal	2,010	1,719	85.5%	231.8	6.7	F
SB	Left Turn	480	458	95.4%	285.4	101.1	F
	Through	1,670	1,662	99.5%	48.8	6.6	D
	Right Turn	260	258	99.0%	17.1	5.7	B
	Subtotal	2,410	2,378	98.7%	90.2	21.3	F
EB	Left Turn	790	686	86.8%	93.1	8.2	F
	Through						
	Right Turn	290	243	83.6%	43.2	4.9	D
	Subtotal	1,080	928	86.0%	79.8	7.3	E
WB	Left Turn						
	Through						
	Right Turn	800	806	100.7%	6.2	1.5	A
	Subtotal	800	806	100.7%	6.2	1.5	A
Total		6,300	5,831	92.6%	119.2	8.9	F

Intersection 5

7th Street/16th Street

Signal

Direction	Movement	Volume (vph)		Percent Served	GEH	Total Delay (sec/veh)		
		Demand	Served			Average	Std. Dev.	LOS
NB	Left Turn	280	218	77.8%	3.9	171.3	19.8	F
	Through	390	297	76.0%	5.0	172.0	10.1	F
	Right Turn	110	82	74.7%	2.8	134.1	17.6	F
	Subtotal	780	597	76.5%	7.0	166.7	13.3	F
SB	Left Turn	130	127	97.5%	0.3	300.6	157.4	F
	Through	100	102	101.7%	0.2	200.4	61.7	F
	Right Turn	40	37	92.8%	0.5	178.8	62.6	F
	Subtotal	270	266	98.3%	0.3	249.6	108.5	F
EB	Left Turn	50	36	71.8%	2.2	188.3	40.7	F
	Through	580	422	72.8%	7.0	198.9	35.2	F
	Right Turn	120	88	72.9%	3.2	203.1	43.8	F
	Subtotal	750	546	72.8%	8.0	199.1	35.2	F
WB	Left Turn	120	125	103.9%	0.4	57.0	8.9	E
	Through	500	491	98.2%	0.4	54.4	10.9	D
	Right Turn	170	169	99.4%	0.1	42.0	7.3	D
	Subtotal	790	785	99.3%	0.2	52.3	7.8	D
Total		2,590	2,192	84.6%	8.1	136.7	11.0	F

Intersection 6

Owens Street/16th Street

Signal

Direction	Movement	Volume (vph)		Percent Served	GEH	Total Delay (sec/veh)		
		Demand	Served			Average	Std. Dev.	LOS
NB	Left Turn							
	Through							
	Right Turn							
	Subtotal							
SB	Left Turn	60	62	102.7%	0.2	18.8	4.6	B
	Through							
	Right Turn	110	107	97.6%	0.2	7.3	0.7	A
	Subtotal	170	169	99.4%	0.1	11.8	2.0	B
EB	Left Turn	250	194	77.4%	3.8	20.0	4.6	B
	Through	570	438	76.9%	5.9	3.3	1.3	A
	Right Turn							
	Subtotal	820	632	77.1%	7.0	8.6	2.5	A
WB	Left Turn							
	Through	680	675	99.3%	0.2	13.7	2.1	B
	Right Turn	120	124	103.1%	0.3	12.8	1.7	B
	Subtotal	800	799	99.9%	0.0	13.5	1.9	B
Total		1,790	1,600	89.4%	4.6	11.3	1.5	B

Intersection 5

7th Street/16th Street

Signal

Direction	Movement	Volume (vph)		Percent Served	GEH	Total Delay (sec/veh)		
		Demand	Served			Average	Std. Dev.	LOS
NB	Left Turn	160	130	80.9%	2.5	200.7	9.2	F
	Through	350	287	82.1%	3.5	198.7	18.0	F
	Right Turn	50	41	81.0%	1.4	140.4	10.0	F
	Subtotal	560	457	81.6%	4.6	194.3	13.3	F
SB	Left Turn	40	86	214.5%	5.8	136.4	35.4	F
	Through	140	134	95.9%	0.5	125.6	42.7	F
	Right Turn	80	39	48.1%	5.4	100.9	42.0	F
	Subtotal	260	259	99.4%	0.1	126.5	36.7	F
EB	Left Turn	80	69	85.6%	1.3	209.4	41.4	F
	Through	530	490	92.5%	1.8	196.6	24.2	F
	Right Turn	80	77	95.8%	0.4	208.1	28.1	F
	Subtotal	690	636	92.1%	2.1	198.1	20.4	F
WB	Left Turn	150	146	97.1%	0.4	68.7	14.2	E
	Through	750	738	98.4%	0.4	63.4	12.7	E
	Right Turn	360	348	96.6%	0.7	67.6	8.9	E
	Subtotal	1,260	1,232	97.7%	0.8	65.2	10.7	E
Total		2,770	2,583	93.2%	3.6	119.9	7.0	F

Intersection 6

Owens Street/16th Street

Signal

Direction	Movement	Volume (vph)		Percent Served	GEH	Total Delay (sec/veh)		
		Demand	Served			Average	Std. Dev.	LOS
NB	Left Turn							
	Through							
	Right Turn							
	Subtotal							
SB	Left Turn	100	100	100.3%	0.0	19.2	4.4	B
	Through							
	Right Turn	210	209	99.3%	0.1	39.2	15.5	D
	Subtotal	310	309	99.6%	0.1	32.9	10.7	C
EB	Left Turn	120	110	92.0%	0.9	21.6	6.3	C
	Through	550	505	91.9%	1.9	6.3	3.3	A
	Right Turn							
	Subtotal	670	616	91.9%	2.1	8.9	3.2	A
WB	Left Turn							
	Through	1,050	1,022	97.4%	0.9	62.0	27.0	E
	Right Turn	90	94	103.9%	0.4	61.2	29.1	E
	Subtotal	1,140	1,116	97.9%	0.7	61.9	27.1	E
Total		2,120	2,040	96.2%	1.7	40.2	16.1	D

Intersection 59

Alma Street/Ravenswood Ave

Side-street Stop

Direction	Movement	Volume (vph)		Percent Served	GEH	Total Delay (sec/veh)		
		Demand	Served			Average	Std. Dev.	LOS
NB	Left Turn	20	19	93.5%	0.3	24.8	9.5	C
	Through	10	10	99.0%	0.0	21.3	20.0	C
	Right Turn	10	10	96.0%	0.1	8.1	3.7	A
	Subtotal	40	38	95.5%	0.3	19.4	8.3	C
SB	Left Turn	10	14	138.0%	1.1	81.0	82.8	F
	Through	10	11	112.0%	0.4	77.0	69.4	F
	Right Turn	40	37	92.5%	0.5	72.8	73.3	F
	Subtotal	60	62	103.3%	0.3	75.8	70.5	F
EB	Left Turn	30	33	108.3%	0.4	18.7	11.8	C
	Through	680	734	107.9%	2.0	12.1	2.9	B
	Right Turn	290	307	105.9%	1.0	15.3	2.1	C
	Subtotal	1,000	1,074	107.4%	2.3	13.2	2.7	B
WB	Left Turn	10	11	112.0%	0.4	20.9	11.0	C
	Through	770	780	101.3%	0.4	25.9	10.2	D
	Right Turn	30	30	98.7%	0.1	21.8	16.4	C
	Subtotal	810	821	101.4%	0.4	25.8	10.1	D
Total		1,910	1,995	104.4%	1.9	31.2	5.9	D

Intersection 60

El Camino Real/Ravenswood Ave

Signal

Direction	Movement	Volume (vph)		Percent Served	GEH	Total Delay (sec/veh)		
		Demand	Served			Average	Std. Dev.	LOS
NB	Left Turn	110	110	100.2%	0.0	112.3	17.3	F
	Through	1,240	1,178	95.0%	1.8	95.0	23.4	F
	Right Turn	690	670	97.1%	0.8	144.7	35.0	F
	Subtotal	2,040	1,958	96.0%	1.8	113.5	26.3	F
SB	Left Turn	200	208	103.8%	0.5	173.3	31.1	F
	Through	1,530	1,501	98.1%	0.8	67.5	16.8	E
	Right Turn	30	33	110.3%	0.6	85.7	19.0	F
	Subtotal	1,760	1,741	98.9%	0.5	80.6	19.0	F
EB	Left Turn	20	18	88.0%	0.6	295.7	26.6	F
	Through	440	406	92.2%	1.7	321.7	40.7	F
	Right Turn	70	85	121.9%	1.7	266.0	59.2	F
	Subtotal	530	508	95.9%	0.9	311.5	41.8	F
WB	Left Turn	551	539	97.7%	0.5	111.4	30.0	F
	Through	301	306	101.5%	0.3	125.6	23.3	F
	Right Turn	130	110	84.8%	1.8	35.9	9.7	D
	Subtotal	982	954	97.2%	0.9	106.8	18.6	F
Total		5,312	5,162	97.2%	2.1	120.1	11.7	F

Intersection 59

Alma Street/Ravenswood Ave

Side-street Stop

Direction	Movement	Volume (vph)		Percent Served	GEH	Total Delay (sec/veh)		
		Demand	Served			Average	Std. Dev.	LOS
NB	Left Turn	110	79	71.4%	3.2	590.7	201.4	F
	Through	10	7	73.0%	0.9	462.1	173.3	F
	Right Turn	80	58	73.0%	2.6	579.7	261.1	F
	Subtotal	200	144	72.1%	4.3	552.4	139.6	F
SB	Left Turn	10	9	94.0%	0.2	153.9	165.7	F
	Through	10	10	102.0%	0.1	149.4	111.9	F
	Right Turn	60	57	94.3%	0.4	145.6	142.7	F
	Subtotal	80	76	95.3%	0.4	150.1	139.8	F
EB	Left Turn	20	12	61.0%	1.9	81.6	55.3	F
	Through	950	765	80.5%	6.3	19.5	6.5	C
	Right Turn	320	260	81.3%	3.5	24.3	3.9	C
	Subtotal	1,290	1,037	80.4%	7.4	19.3	5.5	C
WB	Left Turn	50	43	85.0%	1.1	79.3	19.2	F
	Through	980	870	88.8%	3.6	83.5	12.5	F
	Right Turn	30	25	84.3%	0.9	56.3	16.2	F
	Subtotal	1,060	938	88.5%	3.9	82.7	12.4	F
Total		2,630	2,196	83.5%	8.8	84.2	5.3	F

Intersection 60

El Camino Real/Ravenswood Ave

Signal

Direction	Movement	Volume (vph)		Percent Served	GEH	Total Delay (sec/veh)		
		Demand	Served			Average	Std. Dev.	LOS
NB	Left Turn	190	158	83.2%	2.4	172.9	21.3	F
	Through	1,540	1,244	80.8%	7.9	174.2	8.4	F
	Right Turn	760	609	80.1%	5.8	460.5	32.6	F
	Subtotal	2,490	2,011	80.8%	10.1	270.6	16.0	F
SB	Left Turn	250	228	91.4%	1.4	217.5	21.8	F
	Through	1,250	1,097	87.8%	4.5	62.7	7.3	E
	Right Turn	60	52	86.2%	1.1	42.9	16.1	D
	Subtotal	1,560	1,377	88.3%	4.8	91.0	9.2	F
EB	Left Turn	50	38	75.0%	1.9	432.0	28.9	F
	Through	310	233	75.2%	4.7	495.4	36.7	F
	Right Turn	140	102	72.5%	3.5	541.9	40.4	F
	Subtotal	500	372	74.4%	6.1	501.0	34.5	F
WB	Left Turn	900	674	74.9%	8.1	80.4	3.3	F
	Through	320	243	76.1%	4.6	80.0	9.7	E
	Right Turn	80	65	81.0%	1.8	34.8	14.1	C
	Subtotal	1,302	982	75.4%	9.5	101.6	7.2	F
Total		5,852	4,743	81.0%	15.2	197.8	10.6	F

Intersection 63 Meadow Drive/Alma Street Signal

Direction	Movement	Volume (vph)		Percent Served	GEH	Total Delay (sec/veh)		
		Demand	Served			Average	Std. Dev.	LOS
NB	Left Turn	120	79	66.0%	4.1	124.5	14.4	F
	Through	2,090	1,449	69.3%	15.2	101.9	9.5	F
	Right Turn	60	45	74.3%	2.1	96.2	12.0	F
	Subtotal	2,270	1,573	69.3%	15.9	102.9	9.4	F
SB	Left Turn	60	60	100.0%	0.0	234.0	38.6	F
	Through	1,230	1,207	98.2%	0.7	89.6	21.8	F
	Right Turn	210	209	99.7%	0.0	66.4	19.8	E
	Subtotal	1,500	1,477	98.4%	0.6	93.2	21.9	F
EB	Left Turn	350	240	68.6%	6.4	266.6	4.1	F
	Through	200	140	70.0%	4.6	273.8	10.8	F
	Right Turn	130	84	64.9%	4.4	265.9	9.7	F
	Subtotal	680	465	68.3%	9.0	268.6	3.9	F
WB	Left Turn	130	97	74.8%	3.1	246.0	10.3	F
	Through	400	292	73.1%	5.8	248.5	6.2	F
	Right Turn	90	63	69.9%	3.1	237.0	7.6	F
	Subtotal	620	453	73.0%	7.2	246.4	5.7	F
Total		5,070	3,967	78.2%	16.4	135.1	10.0	F

Intersection 68 Alma Street/Charleston Road Signal

Direction	Movement	Volume (vph)		Percent Served	GEH	Total Delay (sec/veh)		
		Demand	Served			Average	Std. Dev.	LOS
NB	Left Turn	440	278	63.1%	8.6	525.0	78.6	F
	Through	1,800	1,212	67.3%	15.2	244.9	42.7	F
	Right Turn	60	42	70.2%	2.5	241.3	38.3	F
	Subtotal	2,300	1,532	66.6%	17.5	291.6	45.6	F
SB	Left Turn	80	70	87.3%	1.2	292.3	55.7	F
	Through	1,330	1,222	91.8%	3.0	81.7	8.4	F
	Right Turn	80	71	88.5%	1.1	59.4	8.8	E
	Subtotal	1,490	1,362	91.4%	3.4	90.5	11.0	F
EB	Left Turn	190	169	88.9%	1.6	79.8	5.8	E
	Through	520	466	89.6%	2.4	85.2	3.8	F
	Right Turn	300	269	89.5%	1.9	80.0	5.4	E
	Subtotal	1,010	903	89.4%	3.4	82.6	1.6	F
WB	Left Turn	80	53	65.9%	3.4	236.5	18.9	F
	Through	450	306	68.1%	7.4	250.7	24.0	F
	Right Turn	250	161	64.4%	6.2	256.8	38.7	F
	Subtotal	780	520	66.7%	10.2	251.4	26.7	F
Total		5,580	4,318	77.4%	17.9	179.6	11.2	F

Intersection 67 Meadow Drive/Park Ave Side-street Stop

Direction	Movement	Volume (vph)		Percent Served	GEH	Total Delay (sec/veh)		
		Demand	Served			Average	Std. Dev.	LOS
NB	Left Turn	10	5	45.0%	2.0	1292.6	975.0	F
	Through							
	Right Turn	50	18	36.2%	5.5	1704.6	488.4	F
	Subtotal	60	23	37.7%	5.8	1521.1	602.2	F
SB	Left Turn							
	Through							
	Right Turn							
	Subtotal							
EB	Left Turn							
	Through	630	448	71.1%	7.8	204.6	12.8	F
	Right Turn	10	7	70.0%	1.0	177.7	71.7	F
	Subtotal	640	455	71.1%	7.9	204.0	12.0	F
WB	Left Turn							
	Through	600	471	78.6%	5.6	1.3	0.3	A
	Right Turn	130	108	83.4%	2.0	2.5	0.7	A
	Subtotal	730	580	79.4%	5.9	1.5	0.3	A
Total		1,430	1,058	74.0%	10.6	132.3	27.4	F

Intersection 63 Meadow Drive/Alma Street Signal

Direction	Movement	Volume (vph)		Percent Served	Total Delay (sec/veh)			
		Demand	Served		GEH	Average	Std. Dev.	LOS
NB	Left Turn	80	58	72.3%	2.7	78.6	12.1	E
	Through	1,520	1,157	76.1%	9.9	38.4	6.2	D
	Right Turn	80	60	75.5%	2.3	36.8	8.6	D
	Subtotal	1,680	1,276	75.9%	10.5	40.7	6.4	D
SB	Left Turn	70	43	61.6%	3.6	416.3	26.1	F
	Through	1,700	1,087	63.9%	16.4	298.7	35.1	F
	Right Turn	300	193	64.3%	6.8	264.9	29.1	F
	Subtotal	2,070	1,323	63.9%	18.1	297.7	32.9	F
EB	Left Turn	220	158	71.9%	4.5	237.6	4.4	F
	Through	280	201	71.8%	5.1	242.4	5.9	F
	Right Turn	100	74	73.8%	2.8	229.5	13.4	F
	Subtotal	600	433	72.2%	7.3	238.2	4.3	F
WB	Left Turn	90	85	94.0%	0.6	148.8	58.9	F
	Through	300	293	97.7%	0.4	144.3	56.6	F
	Right Turn	80	74	92.1%	0.7	127.7	54.9	F
	Subtotal	470	451	96.0%	0.9	142.3	56.3	F
Total		4,820	3,483	72.3%	20.7	176.1	14.8	F

Intersection 68 Alma Street/Charleston Road Signal

Direction	Movement	Volume (vph)		Percent Served	Total Delay (sec/veh)			
		Demand	Served		GEH	Average	Std. Dev.	LOS
NB	Left Turn	350	273	78.1%	4.3	234.6	9.6	F
	Through	1,420	1,202	84.7%	6.0	215.9	8.6	F
	Right Turn	80	72	90.4%	0.9	210.1	16.3	F
	Subtotal	1,850	1,548	83.7%	7.3	219.2	5.6	F
SB	Left Turn	450	273	60.8%	9.3	315.6	12.1	F
	Through	1,270	821	64.6%	13.9	229.3	8.4	F
	Right Turn	180	114	63.4%	5.4	183.9	10.5	F
	Subtotal	1,900	1,208	63.6%	17.5	245.2	8.9	F
EB	Left Turn	150	72	48.1%	7.4	203.2	13.4	F
	Through	630	323	51.3%	14.1	201.8	6.6	F
	Right Turn	670	350	52.2%	14.2	196.9	6.2	F
	Subtotal	1,450	745	51.4%	21.3	199.6	5.1	F
WB	Left Turn	140	70	49.7%	6.9	181.2	12.6	F
	Through	880	417	47.3%	18.2	184.5	7.8	F
	Right Turn	110	52	47.6%	6.4	169.3	19.8	F
	Subtotal	1,130	539	47.7%	20.5	182.4	7.0	F
Total		6,330	4,040	63.8%	31.8	218.5	7.7	F

Intersection 67 Meadow Drive/Park Ave Side-street Stop

Direction	Movement	Volume (vph)		Percent Served	Total Delay (sec/veh)			
		Demand	Served		GEH	Average	Std. Dev.	LOS
NB	Left Turn	10	9	92.0%	0.3	480.1	379.9	F
	Through							
	Right Turn	30	24	79.3%	1.2	695.3	349.5	F
	Subtotal	40	33	82.5%	1.2	636.8	312.6	F
SB	Left Turn							
	Through							
	Right Turn	20	17	85.0%	0.7	6.4	2.0	A
	Subtotal	20	17	85.0%	0.7	6.4	2.0	A
EB	Left Turn							
	Through	570	412	72.3%	7.1	166.0	7.1	F
	Right Turn	30	21	70.3%	1.8	160.8	33.9	F
	Subtotal	600	433	72.2%	7.3	165.5	6.8	F
WB	Left Turn							
	Through	540	432	80.0%	4.9	1.5	0.9	A
	Right Turn	140	111	79.1%	2.6	2.6	0.8	A
	Subtotal	680	543	79.8%	5.6	1.7	0.8	A
Total		1,340	1,026	76.5%	9.1	98.4	13.8	F

Intersection 66

Alma Street/Churchill Street

Signal

Direction	Movement	Volume (vph)		Percent Served	GEH	Total Delay (sec/veh)		
		Demand	Served			Average	Std. Dev.	LOS
NB	Left Turn	340	223	65.4%	7.0	489.7	61.1	F
	Through	1,860	1,322	71.1%	13.5	162.0	41.6	F
	Right Turn	30	19	64.3%	2.2	156.2	59.5	F
	Subtotal	2,230	1,564	70.1%	15.3	208.4	46.8	F
SB	Left Turn	10	11	112.0%	0.4	78.2	40.3	E
	Through	800	835	104.4%	1.2	38.7	3.6	D
	Right Turn	320	339	105.8%	1.0	30.8	2.2	C
	Subtotal	1,130	1,185	104.9%	1.6	36.8	2.8	D
EB	Left Turn	60	62	103.3%	0.3	88.6	16.6	F
	Through	150	149	99.6%	0.0	84.5	21.0	F
	Right Turn	100	98	98.3%	0.2	31.1	15.0	C
	Subtotal	310	310	99.9%	0.0	69.4	18.2	E
WB	Left Turn	100	107	107.1%	0.7	202.3	140.7	F
	Through	60	44	72.8%	2.3	186.6	150.4	F
	Right Turn	10	10	100.0%	0.0	150.7	174.9	F
	Subtotal	170	161	94.6%	0.7	196.2	142.2	F
Total		3,840	3,220	83.8%	10.4	124.1	16.8	F

VISSIM Post-Processor
Average Results from 10 Runs
Volume and Delay by Movement

Caltrain Electrification
Existing Conditions
PM Peak Hour

Intersection 66

Alma Street/Churchill Street

Signal

Direction	Movement	Volume (vph)		Percent Served	GEH	Total Delay (sec/veh)		
		Demand	Served			Average	Std. Dev.	LOS
NB	Left Turn	170	147	86.3%	1.9	411.8	93.7	F
	Through	1,180	1,167	98.9%	0.4	100.7	35.6	F
	Right Turn	60	54	89.5%	0.8	113.2	44.6	F
	Subtotal	1,410	1,368	97.0%	1.1	137.9	44.1	F
SB	Left Turn	30	25	82.3%	1.0	261.4	33.3	F
	Through	1,820	1,451	79.7%	9.1	202.9	9.9	F
	Right Turn	150	118	78.9%	2.7	190.8	14.7	F
	Subtotal	2,000	1,594	79.7%	9.6	202.8	10.3	F
EB	Left Turn	300	182	60.8%	7.6	222.8	13.5	F
	Through	330	196	59.3%	8.3	232.3	12.8	F
	Right Turn	270	165	61.1%	7.1	209.0	17.2	F
	Subtotal	900	543	60.3%	13.3	222.1	12.8	F
WB	Left Turn	130	107	82.4%	2.1	342.4	34.5	F
	Through	150	116	77.5%	2.9	333.2	29.9	F
	Right Turn	20	15	75.0%	1.2	337.0	56.8	F
	Subtotal	300	238	79.5%	3.8	338.4	31.1	F
Total		4,610	3,743	81.2%	13.4	192.0	15.3	F

Intersection 70

Rengstorff/Central Expressway

Signal

Direction	Movement	Volume (vph)		Percent Served	Total Delay (sec/veh)		
		Demand	Served		Average	Std. Dev.	LOS
NB	Left Turn	430	303	70.5%	146.7	7.4	F
	Through	820	564	68.8%	155.5	7.0	F
	Right Turn	100	70	69.5%	145.2	16.2	F
	Subtotal	1,350	937	69.4%	152.0	6.6	F
SB	Left Turn	60	52	85.8%	233.0	40.7	F
	Through	540	469	86.8%	252.5	33.5	F
	Right Turn	140	121	86.2%	256.0	42.0	F
	Subtotal	740	641	86.6%	251.6	33.7	F
EB	Left Turn	150	142	94.7%	257.0	53.7	F
	Through	1,270	1,217	95.8%	157.6	11.5	F
	Right Turn	250	246	98.6%	150.2	14.7	F
	Subtotal	1,670	1,606	96.1%	167.0	15.0	F
WB	Left Turn	140	86	61.6%	620.7	119.8	F
	Through	1,790	1,214	67.8%	282.4	30.4	F
	Right Turn	330	232	70.2%	177.9	18.8	F
	Subtotal	2,260	1,532	67.8%	290.8	36.2	F
Total		6,020	4,715	78.3%	214.2	12.2	F

Intersection 71

Moffett/Central Expressway

Signal

Direction	Movement	Volume (vph)		Percent Served	Total Delay (sec/veh)		
		Demand	Served		Average	Std. Dev.	LOS
NB	Left Turn	210	145	69.1%	88.0	8.4	F
	Through	470	376	79.9%	102.3	13.4	F
	Right Turn	310	222	71.6%	112.2	11.5	F
	Subtotal	990	743	75.0%	102.2	10.2	F
SB	Left Turn	130	130	99.8%	110.4	28.5	F
	Through	370	378	102.2%	108.5	26.3	F
	Right Turn	260	264	101.5%	95.3	29.6	F
	Subtotal	760	772	101.6%	104.3	27.0	F
EB	Left Turn	320	296	92.4%	307.5	32.2	F
	Through	1,210	1,089	90.0%	127.7	10.9	F
	Right Turn	150	132	88.1%	85.6	17.5	F
	Subtotal	1,680	1,517	90.3%	160.0	15.1	F
WB	Left Turn	130	67	51.8%	458.4	45.6	F
	Through	1,870	910	48.7%	381.1	37.8	F
	Right Turn	380	180	47.4%	372.6	46.0	F
	Subtotal	2,380	1,158	48.6%	384.0	38.4	F
Total		5,810	4,189	72.1%	206.2	14.1	F

VISSIM Post-Processor
Average Results from 10 Runs
Volume and Delay by Movement

Caltrain Electrification
2040 No Project
PM Peak Hour

Intersection 70

Rengstorff/Central Expressway

Signal

Direction	Movement	Volume (vph)		Percent Served	Total Delay (sec/veh)		
		Demand	Served		Average	Std. Dev.	LOS
NB	Left Turn	210	169	80.4%	170.8	13.9	F
	Through	620	486	78.4%	178.3	11.0	F
	Right Turn	130	106	81.6%	188.2	16.3	F
	Subtotal	960	761	79.3%	178.0	10.6	F
SB	Left Turn	420	298	71.0%	183.8	10.1	F
	Through	970	699	72.1%	181.6	7.4	F
	Right Turn	50	35	69.8%	172.2	20.8	F
	Subtotal	1,440	1,032	71.7%	181.9	6.7	F
EB	Left Turn	320	254	79.3%	368.6	48.4	F
	Through	1,290	1,011	78.3%	186.6	15.4	F
	Right Turn	170	132	77.6%	147.3	12.7	F
	Subtotal	1,780	1,396	78.4%	217.0	22.0	F
WB	Left Turn	190	141	74.3%	561.4	60.2	F
	Through	1,340	1,000	74.6%	273.8	15.6	F
	Right Turn	150	112	74.5%	133.0	14.5	F
	Subtotal	1,680	1,253	74.6%	287.6	19.6	F
Total		5,860	4,442	75.8%	217.4	10.3	F

Intersection 71

Moffett/Central Expressway

Signal

Direction	Movement	Volume (vph)		Percent Served	Total Delay (sec/veh)		
		Demand	Served		Average	Std. Dev.	LOS
NB	Left Turn	140	82	58.8%	93.0	8.0	F
	Through	800	504	63.0%	102.7	11.0	F
	Right Turn	150	87	57.9%	108.5	12.9	F
	Subtotal	1,090	673	61.7%	102.4	10.2	F
SB	Left Turn	50	24	48.0%	234.8	63.4	F
	Through	790	425	53.7%	237.1	27.6	F
	Right Turn	270	137	50.9%	237.0	28.7	F
	Subtotal	1,110	586	52.8%	236.5	26.8	F
EB	Left Turn	110	70	63.3%	244.5	15.8	F
	Through	2,350	1,463	62.3%	214.8	16.4	F
	Right Turn	200	119	59.7%	160.3	14.0	F
	Subtotal	2,660	1,652	62.1%	212.1	16.6	F
WB	Left Turn	230	171	74.3%	343.5	34.0	F
	Through	1,650	1,311	79.4%	178.3	11.2	F
	Right Turn	110	86	78.5%	156.8	15.5	F
	Subtotal	1,990	1,568	78.8%	198.5	13.4	F
Total		6,850	4,479	65.4%	193.7	6.6	F

VISSIM Post-Processor
Average Results from 10 Runs
Volume and Delay by Movement

Caltrain Electrification
2040 No Project
AM Peak Hour

Intersection 75

Mary/Evelyn

Signal

Direction	Movement	Volume (vph)		Percent Served	Total Delay (sec/veh)		
		Demand	Served		Average	Std. Dev.	LOS
NB	Left Turn	140	114	81.4%	101.0	18.7	F
	Through	1,760	1,490	84.6%	121.7	6.8	F
	Right Turn	40	34	84.8%	125.3	16.5	F
	Subtotal	1,940	1,637	84.4%	120.4	6.4	F
SB	Left Turn	130	132	101.2%	97.2	32.2	F
	Through	490	489	99.8%	46.7	9.1	D
	Right Turn	290	291	100.2%	69.3	22.4	E
	Subtotal	910	911	100.1%	61.8	14.7	E
EB	Left Turn	290	285	98.1%	144.6	46.5	F
	Through	210	219	104.4%	26.3	4.4	C
	Right Turn	50	47	93.0%	17.1	5.8	B
	Subtotal	550	550	100.1%	86.4	27.0	F
WB	Left Turn	110	105	95.8%	97.4	24.9	F
	Through	720	702	97.4%	79.9	19.6	E
	Right Turn	220	220	99.9%	86.0	26.6	F
	Subtotal	1,050	1,027	97.8%	83.1	21.2	F
Total		4,450	4,126	92.7%	92.1	5.2	F

VISSIM Post-Processor
Average Results from 10 Runs
Volume and Delay by Movement

Catrain Electrification
2040 No Project
PM Peak Hour

Intersection 75

Mary/Evelyn

Signal

Direction	Movement	Volume (vph)		Percent Served	Total Delay (sec/veh)		
		Demand	Served		Average	Std. Dev.	LOS
NB	Left Turn	50	48	95.4%	45.9	11.9	D
	Through	760	751	98.8%	52.0	4.6	D
	Right Turn	40	43	108.0%	44.4	11.9	D
	Subtotal	850	842	99.0%	51.2	4.6	D
SB	Left Turn	480	312	65.0%	122.6	10.4	F
	Through	2,260	1,484	65.6%	97.1	6.6	F
	Right Turn	540	355	65.7%	109.1	8.7	F
	Subtotal	3,280	2,150	65.6%	102.9	4.7	F
EB	Left Turn	490	280	57.2%	270.3	25.1	F
	Through	660	355	53.7%	52.6	5.1	D
	Right Turn	170	91	53.3%	49.7	11.9	D
	Subtotal	1,320	726	55.0%	136.5	16.5	F
WB	Left Turn	60	63	104.7%	49.1	9.6	D
	Through	290	288	99.3%	39.4	3.1	D
	Right Turn	170	168	98.6%	28.6	3.8	C
	Subtotal	520	519	99.7%	37.2	2.9	D
Total		5,970	4,236	71.0%	88.8	3.6	F

2040 Project



Intersection 1

4th Street/King Street

Signal

Direction	Movement	Volume (vph)		Percent Served	GEH	Total Delay (sec/veh)		
		Demand	Served			Average	Std. Dev.	LOS
NB	Left Turn	10	10	97.0%	0.1	41.3	28.7	D
	Through	60	111	185.7%	5.6	28.8	6.7	C
	Right Turn	40	52	128.8%	1.7	15.5	4.6	B
	Subtotal	110	173	156.9%	5.3	26.4	3.5	C
SB	Left Turn	130	114	87.6%	1.5	89.2	11.1	F
	Through	460	440	95.6%	0.9	51.3	4.9	D
	Right Turn	270	253	93.5%	1.1	34.8	5.3	C
	Subtotal	860	806	93.8%	1.9	52.7	4.6	D
EB	Left Turn	100	65	65.2%	3.8	390.0	22.4	F
	Through	1,790	1,259	70.4%	13.6	238.4	19.5	F
	Right Turn	10	7	72.0%	1.0	95.0	57.1	F
	Subtotal	1,900	1,332	70.1%	14.1	244.0	19.6	F
WB	Left Turn	40	39	98.5%	0.1	181.3	68.8	F
	Through	850	922	108.5%	2.4	167.2	62.9	F
	Right Turn	30	69	229.7%	5.5	105.9	53.9	F
	Subtotal	920	1,030	112.0%	3.5	163.9	61.0	F
Total		3,790	3,341	88.1%	7.5	160.3	15.5	F

Intersection 2

4th Street/Townsend Street

Signal

Direction	Movement	Volume (vph)		Percent Served	GEH	Total Delay (sec/veh)		
		Demand	Served			Average	Std. Dev.	LOS
NB	Left Turn							
	Through	30	23	77.0%	1.3	27.2	9.4	C
	Right Turn	160	163	101.9%	0.2	14.8	3.1	B
	Subtotal	190	186	97.9%	0.3	16.6	3.6	B
SB	Left Turn							
	Through	530	561	105.9%	1.3	325.5	67.3	F
	Right Turn	80	61	76.5%	2.2	455.1	68.0	F
	Subtotal	610	622	102.0%	0.5	339.2	65.4	F
EB	Left Turn							
	Through	380	415	109.1%	1.7	38.8	15.7	D
	Right Turn	160	158	98.9%	0.1	100.9	52.2	F
	Subtotal	540	573	106.1%	1.4	57.6	25.0	E
WB	Left Turn	170	167	98.4%	0.2	94.3	81.6	F
	Through	220	229	103.9%	0.6	18.2	7.1	B
	Right Turn							
	Subtotal	390	396	101.5%	0.3	50.6	40.0	D
Total		1,730	1,777	102.7%	1.1	154.8	26.0	F

Intersection 1

4th Street/King Street

Signal

Direction	Movement	Volume (vph)		Percent Served	GEH	Total Delay (sec/veh)		
		Demand	Served			Average	Std. Dev.	LOS
NB	Left Turn	20	19	94.0%	0.3	64.2	15.5	E
	Through	70	123	176.3%	5.4	28.8	5.4	C
	Right Turn	50	62	123.0%	1.5	15.7	3.2	B
	Subtotal	140	204	145.5%	4.9	28.5	4.6	C
SB	Left Turn	120	93	77.4%	2.6	91.1	17.9	F
	Through	300	266	88.5%	2.1	59.2	7.0	E
	Right Turn	600	493	82.1%	4.6	50.0	7.3	D
	Subtotal	1,020	851	83.4%	5.5	57.9	7.1	E
EB	Left Turn	150	120	79.9%	2.6	383.5	28.8	F
	Through	1,470	1,221	83.1%	6.8	227.9	19.5	F
	Right Turn	20	16	81.5%	0.9	120.0	20.2	F
	Subtotal	1,640	1,357	82.8%	7.3	240.9	18.6	F
WB	Left Turn	30	27	88.3%	0.7	305.3	22.7	F
	Through	1,020	982	96.3%	1.2	275.4	20.9	F
	Right Turn	20	55	275.0%	5.7	162.0	45.0	F
	Subtotal	1,070	1,063	99.4%	0.2	271.0	21.0	F
Total		3,870	3,475	89.8%	6.5	190.8	9.3	F

Intersection 2

4th Street/Townsend Street

Signal

Direction	Movement	Volume (vph)		Percent Served	GEH	Total Delay (sec/veh)		
		Demand	Served			Average	Std. Dev.	LOS
NB	Left Turn							
	Through	20	14	71.0%	1.4	30.2	16.8	C
	Right Turn	220	226	102.9%	0.4	16.3	2.5	B
	Subtotal	240	241	100.3%	0.0	17.0	2.8	B
SB	Left Turn							
	Through	640	566	88.4%	3.0	359.4	31.7	F
	Right Turn	90	65	72.0%	2.9	480.1	58.0	F
	Subtotal	730	631	86.4%	3.8	371.8	30.3	F
EB	Left Turn							
	Through	290	326	112.2%	2.0	31.6	3.4	C
	Right Turn	130	130	99.6%	0.0	54.3	16.8	D
	Subtotal	420	455	108.3%	1.7	38.1	5.9	D
WB	Left Turn	250	232	92.6%	1.2	269.9	60.9	F
	Through	310	314	101.2%	0.2	72.2	26.6	E
	Right Turn							
	Subtotal	560	545	97.4%	0.6	161.4	44.2	F

VISSIM Post-Processor
Average Results from 10 Runs
Volume and Delay by Movement

Caltrain Electrification
2040 Project
AM Peak Hour

Intersection 18

California/Broadway

Signal

Direction	Movement	Volume (vph)		Percent Served	Total Delay (sec/veh)		
		Demand	Served		Average	Std. Dev.	LOS
NB	Left Turn	100	98	97.5%	114.9	10.3	F
	Through	410	396	96.6%	76.9	8.1	E
	Right Turn	500	507	101.5%	30.7	7.7	C
	Subtotal	1,010	1,001	99.1%	57.8	4.8	E
SB	Left Turn	440	303	68.8%	144.4	10.2	F
	Through	540	391	72.5%	133.6	9.5	F
	Right Turn	40	28	69.8%	124.0	21.6	F
	Subtotal	1,020	722	70.8%	138.1	6.6	F
EB	Left Turn	10	9	93.0%	80.6	55.1	F
	Through	400	406	101.4%	88.5	30.1	F
	Right Turn	40	38	95.5%	77.4	39.8	E
	Subtotal	450	453	100.7%	87.4	30.0	F
WB	Left Turn	280	176	62.8%	17.4	2.0	B
	Through	310	201	65.0%	6.7	1.7	A
	Right Turn	300	195	64.9%	2.3	1.2	A
	Subtotal	890	572	64.3%	8.9	1.2	A
Total		3,370	2,748	81.5%	71.9	6.2	E

Intersection 19

Carolan/Broadway

Signal

Direction	Movement	Volume (vph)		Percent Served	Total Delay (sec/veh)		
		Demand	Served		Average	Std. Dev.	LOS
NB	Left Turn	210	193	91.7%	256.4	62.5	F
	Through	1	10	980.0%	253.7	113.1	F
	Right Turn	570	524	91.9%	106.7	10.2	F
	Subtotal	781	727	93.0%	156.8	26.3	F
SB	Left Turn						
	Through						
	Right Turn						
	Subtotal						
EB	Left Turn	10	8	84.0%	6.2	8.0	A
	Through	1,160	1,057	91.1%	2.4	0.4	A
	Right Turn	170	154	90.4%	2.6	1.1	A
	Subtotal	1,340	1,219	90.9%	2.4	0.3	A
WB	Left Turn	450	221	49.2%	367.8	17.6	F
	Through	680	381	56.0%	99.7	28.9	F
	Right Turn	10	6	61.0%	98.3	109.1	F
	Subtotal	1,140	608	53.4%	195.4	26.7	F
Total		3,261	2,554	78.3%	90.8	7.2	F

VISSIM Post-Processor
Average Results from 10 Runs
Volume and Delay by Movement

Caltrain Electrification
2040 Project
PM Peak Hour

Intersection 18

California/Broadway

Signal

Direction	Movement	Volume (vph)		Percent Served	Total Delay (sec/veh)		
		Demand	Served		Average	Std. Dev.	LOS
NB	Left Turn	50	50	99.2%	69.9	10.0	E
	Through	450	458	101.7%	66.9	8.4	E
	Right Turn	340	340	100.1%	12.2	2.6	B
	Subtotal	840	848	100.9%	45.8	5.6	D
SB	Left Turn	410	239	58.3%	162.1	10.5	F
	Through	560	336	59.9%	169.9	16.3	F
	Right Turn	40	23	56.5%	176.0	18.2	F
	Subtotal	1,010	597	59.1%	167.2	13.5	F
EB	Left Turn	20	21	104.0%	167.9	64.1	F
	Through	290	295	101.7%	96.2	15.3	F
	Right Turn	50	48	96.2%	70.3	27.1	E
	Subtotal	360	364	101.1%	96.0	15.6	F
WB	Left Turn	360	285	79.1%	14.7	1.7	B
	Through	500	415	82.9%	7.4	0.8	A
	Right Turn	480	404	84.1%	3.9	1.2	A
	Subtotal	1,340	1,103	82.3%	8.0	0.9	A
Total		3,550	2,912	82.0%	63.0	4.2	E

Intersection 19

Carolan/Broadway

Signal

Direction	Movement	Volume (vph)		Percent Served	Total Delay (sec/veh)		
		Demand	Served		Average	Std. Dev.	LOS
NB	Left Turn	150	141	93.9%	191.5	44.2	F
	Through	10	10	96.0%	173.8	33.8	F
	Right Turn	500	492	98.4%	50.6	30.6	D
	Subtotal	660	643	97.3%	91.9	29.9	F
SB	Left Turn						
	Through						
	Right Turn						
	Subtotal						
EB	Left Turn	10	8	77.0%	31.2	26.0	C
	Through	920	771	83.8%	3.4	0.6	A
	Right Turn	110	96	86.8%	4.0	2.5	A
	Subtotal	1,040	874	84.1%	3.7	0.4	A
WB	Left Turn	400	317	79.4%	182.6	9.5	F
	Through	1,190	965	81.1%	51.3	9.8	D
	Right Turn	10	9	87.0%	54.7	60.5	D
	Subtotal	1,600	1,291	80.7%	81.8	7.4	F
Total		3,300	2,808	85.1%	60.0	7.1	E

Intersection 45 El Camino Real/Whipple Road Signal

Direction	Movement	Volume (vph)		Percent Served	Total Delay (sec/veh)		
		Demand	Served		Average	Std. Dev.	LOS
NB	Left Turn	80	65	81.5%	119.5	13.8	F
	Through	1,210	981	81.1%	93.0	6.5	F
	Right Turn	450	366	81.4%	73.7	8.0	E
	Subtotal	1,740	1,413	81.2%	89.3	6.1	F
SB	Left Turn	540	471	87.2%	282.0	38.4	F
	Through	830	713	85.9%	90.6	16.2	F
	Right Turn	120	99	82.7%	89.1	22.3	F
	Subtotal	1,490	1,283	86.1%	156.5	23.4	F
EB	Left Turn	170	167	98.2%	190.3	14.4	F
	Through	470	445	94.6%	185.9	13.3	F
	Right Turn	110	101	91.9%	184.9	29.0	F
	Subtotal	750	713	95.0%	186.8	13.3	F
WB	Left Turn	490	489	99.9%	49.8	9.5	D
	Through	300	298	99.4%	39.7	9.2	D
	Right Turn	210	211	100.3%	13.8	4.2	B
	Subtotal	1,000	998	99.8%	39.5	8.1	D
Total		4,980	4,407	88.5%	109.2	4.7	F

Intersection 62 Palo Alto/Alma Side-street Stop

Direction	Movement	Volume (vph)		Percent Served	Total Delay (sec/veh)		
		Demand	Served		Average	Std. Dev.	LOS
NB	Left Turn						
	Through						
	Right Turn						
	Subtotal						
SB	Left Turn	90	87	97.0%	23.9	5.7	C
	Through						
	Right Turn	30	32	107.7%	18.0	8.8	C
	Subtotal	120	120	99.7%	21.9	5.0	C
EB	Left Turn						
	Through	600	572	95.4%	5.0	0.8	A
	Right Turn						
	Subtotal	600	572	95.4%	5.0	0.8	A
WB	Left Turn						
	Through	760	758	99.7%	7.2	1.0	A
	Right Turn	20	21	103.0%	3.3	3.5	A
	Subtotal	780	778	99.8%	7.1	1.0	A
Total		1,500	1,470	98.0%	10.5	0.9	B

Intersection 64 El Camino Real/Sand Hill-Palo Alto Signal

Direction	Movement	Volume (vph)		Percent Served	Total Delay (sec/veh)		
		Demand	Served		Average	Std. Dev.	LOS
NB	Left Turn	140	139	99.3%	92.6	24.0	F
	Through	1,290	1,292	100.1%	86.9	23.4	F
	Right Turn	50	47	94.0%	44.1	28.0	D
	Subtotal	1,480	1,478	99.8%	86.1	23.5	F
SB	Left Turn	550	525	95.5%	270.7	51.4	F
	Through	1,440	1,438	99.9%	65.3	26.0	E
	Right Turn	660	644	97.6%	108.8	54.5	F
	Subtotal	2,650	2,608	98.4%	117.5	29.1	F
EB	Left Turn	280	282	100.7%	58.8	5.5	E
	Through						
	Right Turn	230	225	98.0%	9.6	2.9	A
	Subtotal	510	507	99.5%	38.4	4.4	D
WB	Left Turn						
	Through						
	Right Turn	790	791	100.1%	7.3	1.5	A
	Subtotal	790	791	100.1%	7.3	1.5	A
Total		5,430	5,383	99.1%	85.8	15.6	F

Intersection 45 El Camino Real/Whipple Road Signal

Direction	Movement	Volume (vph)		Percent Served	Total Delay (sec/veh)		
		Demand	Served		Average	Std. Dev.	LOS
NB	Left Turn	100	99	98.9%	103.5	13.0	F
	Through	1,320	1,305	98.9%	67.3	9.4	E
	Right Turn	260	255	97.9%	47.7	11.4	D
	Subtotal	1,680	1,659	98.7%	66.4	10.0	E
SB	Left Turn	410	393	95.9%	145.2	17.5	F
	Through	1,380	1,322	95.8%	72.4	7.6	E
	Right Turn	110	110	100.1%	73.7	10.4	E
	Subtotal	1,900	1,825	96.0%	89.0	8.6	F
EB	Left Turn	180	150	83.6%	267.3	33.5	F
	Through	340	288	84.7%	255.7	36.9	F
	Right Turn	80	66	82.5%	237.3	37.5	F
	Subtotal	600	504	84.1%	256.7	34.4	F
WB	Left Turn	350	357	102.1%	42.3	9.1	D
	Through	450	437	97.1%	39.6	4.9	D
	Right Turn	330	330	100.0%	14.1	2.4	B
	Subtotal	1,130	1,124	99.5%	32.7	4.6	C
Total		5,310	5,112	96.3%	88.3	5.1	F

Intersection 62 Palo Alto/Alma Side-street Stop

Direction	Movement	Volume (vph)		Percent Served	Total Delay (sec/veh)		
		Demand	Served		Average	Std. Dev.	LOS
NB	Left Turn						
	Through						
	Right Turn						
	Subtotal						
SB	Left Turn	10	8	81.0%	21.4	13.5	C
	Through						
	Right Turn	70	69	98.7%	29.6	9.5	D
	Subtotal	80	77	96.5%	28.5	9.1	D
EB	Left Turn						
	Through	670	601	89.7%	11.3	1.5	B
	Right Turn						
	Subtotal	670	601	89.7%	11.3	1.5	B
WB	Left Turn						
	Through	760	760	100.0%	12.1	2.1	B
	Right Turn	170	165	96.8%	8.3	2.4	A
	Subtotal	930	924	99.4%	11.3	1.7	B
Total		1,680	1,602	95.4%	13.1	1.3	B

Intersection 64 El Camino Real/Sand Hill-Palo Alto Signal

Direction	Movement	Volume (vph)		Percent Served	Total Delay (sec/veh)		
		Demand	Served		Average	Std. Dev.	LOS
NB	Left Turn	150	137	91.2%	230.8	14.2	F
	Through	1,600	1,444	90.2%	236.4	12.3	F
	Right Turn	160	142	88.6%	202.3	14.2	F
	Subtotal	1,910	1,723	90.2%	233.2	12.2	F
SB	Left Turn	510	458	89.7%	490.5	105.0	F
	Through	1,540	1,521	98.8%	79.8	44.1	E
	Right Turn	290	278	95.8%	35.1	24.9	D
	Subtotal	2,340	2,257	96.4%	160.2	59.1	F
EB	Left Turn	790	687	87.0%	97.2	8.1	F
	Through						
	Right Turn	260	223	85.8%	46.3	6.2	D
	Subtotal	1,050	910	86.7%	85.2	8.5	F
WB	Left Turn						
	Through						
	Right Turn	830	830	100.0%	8.2	1.9	A
	Subtotal	830	830	100.0%	8.2	1.9	A
Total		6,130	5,720	93.3%	147.2	24.3	F

Intersection 5

7th Street/16th Street

Signal

Direction	Movement	Volume (vph)		Percent Served	GEH	Total Delay (sec/veh)		
		Demand	Served			Average	Std. Dev.	LOS
NB	Left Turn	390	198	50.7%	11.2	196.0	31.3	F
	Through	250	301	120.2%	3.0	198.1	28.4	F
	Right Turn	110	87	78.8%	2.3	149.7	23.6	F
	Subtotal	750	585	78.0%	6.4	189.7	26.9	F
SB	Left Turn	100	123	122.7%	2.2	232.6	48.1	F
	Through	130	99	76.3%	2.9	130.9	36.8	F
	Right Turn	40	39	98.0%	0.1	112.6	48.2	F
	Subtotal	270	261	96.7%	0.5	176.6	44.1	F
EB	Left Turn	40	28	70.0%	2.1	229.5	68.5	F
	Through	590	394	66.7%	8.9	223.5	33.3	F
	Right Turn	130	90	69.1%	3.8	228.5	43.7	F
	Subtotal	760	512	67.3%	9.9	224.7	33.6	F
WB	Left Turn	80	76	95.0%	0.5	41.6	10.3	D
	Through	430	424	98.5%	0.3	38.0	5.7	D
	Right Turn	170	175	103.2%	0.4	27.9	5.7	C
	Subtotal	680	675	99.3%	0.2	35.8	4.3	D
Total		2,460	2,033	82.6%	9.0	150.9	12.0	F

Intersection 6

Owens Street/16th Street

Signal

Direction	Movement	Volume (vph)		Percent Served	GEH	Total Delay (sec/veh)		
		Demand	Served			Average	Std. Dev.	LOS
NB	Left Turn							
	Through							
	Right Turn							
	Subtotal							
SB	Left Turn	60	61	101.3%	0.1	20.0	2.3	B
	Through							
	Right Turn	110	109	98.7%	0.1	6.7	0.9	A
	Subtotal	170	169	99.6%	0.0	11.6	0.9	B
EB	Left Turn	250	182	72.7%	4.6	21.9	5.9	C
	Through	630	427	67.8%	8.8	3.9	1.9	A
	Right Turn							
	Subtotal	880	609	69.2%	9.9	9.1	3.0	A
WB	Left Turn							
	Through	570	566	99.4%	0.2	12.0	1.7	B
	Right Turn	120	121	101.2%	0.1	9.5	2.6	A
	Subtotal	690	688	99.7%	0.1	11.6	1.6	B
Total		1,740	1,466	84.3%	6.8	10.6	1.3	B

Intersection 5

7th Street/16th Street

Signal

Direction	Movement	Volume (vph)		Percent Served	GEH	Total Delay (sec/veh)		
		Demand	Served			Average	Std. Dev.	LOS
NB	Left Turn	140	116	82.6%	2.1	221.1	17.1	F
	Through	340	278	81.9%	3.5	224.4	14.3	F
	Right Turn	50	42	83.0%	1.3	170.5	23.3	F
	Subtotal	530	436	82.2%	4.3	218.4	14.4	F
SB	Left Turn	50	84	167.6%	4.1	182.8	70.1	F
	Through	200	200	99.9%	0.0	183.7	60.2	F
	Right Turn	80	50	62.5%	3.7	168.7	73.6	F
	Subtotal	330	334	101.1%	0.2	181.2	63.0	F
EB	Left Turn	80	67	84.1%	1.5	193.2	29.6	F
	Through	540	470	87.1%	3.1	193.8	18.3	F
	Right Turn	80	71	88.6%	1.0	183.7	31.4	F
	Subtotal	700	609	86.9%	3.6	193.8	16.4	F
WB	Left Turn	180	171	95.1%	0.7	71.5	9.9	E
	Through	730	681	93.3%	1.8	69.8	8.2	E
	Right Turn	370	356	96.2%	0.7	60.7	12.1	E
	Subtotal	1,280	1,208	94.4%	2.0	67.4	7.8	E
Total		2,840	2,586	91.1%	4.9	134.3	11.0	F

Intersection 6

Owens Street/16th Street

Signal

Direction	Movement	Volume (vph)		Percent Served	GEH	Total Delay (sec/veh)		
		Demand	Served			Average	Std. Dev.	LOS
NB	Left Turn							
	Through							
	Right Turn							
	Subtotal							
SB	Left Turn	100	104	104.2%	0.4	19.9	5.9	B
	Through							
	Right Turn	230	226	98.0%	0.3	43.7	17.6	D
	Subtotal	330	330	99.9%	0.0	36.2	13.2	D
EB	Left Turn	110	105	95.6%	0.5	21.4	6.5	C
	Through	560	497	88.7%	2.8	6.0	3.1	A
	Right Turn							
	Subtotal	670	602	89.8%	2.7	8.6	3.8	A
WB	Left Turn							
	Through	1,050	975	92.9%	2.4	95.1	13.2	F
	Right Turn	90	86	95.2%	0.5	90.3	14.1	F
	Subtotal	1,140	1,061	93.0%	2.4	94.8	13.0	F
Total		2,140	1,992	93.1%	3.3	55.8	6.8	E

Intersection 59

Alma Street/Ravenswood Ave

Side-street Stop

Direction	Movement	Volume (vph)		Percent Served	GEH	Total Delay (sec/veh)		
		Demand	Served			Average	Std. Dev.	LOS
NB	Left Turn	20	31	153.0%	2.1	20.3	12.8	C
	Through	10	8	84.0%	0.5	21.9	22.5	C
	Right Turn	10	10	97.0%	0.1	9.0	12.8	A
	Subtotal	40	49	121.8%	1.3	18.8	11.9	C
SB	Left Turn	10	11	108.0%	0.2	65.1	76.8	F
	Through	10	10	101.0%	0.0	57.9	69.5	F
	Right Turn	40	39	97.5%	0.2	69.5	68.0	F
	Subtotal	60	60	99.8%	0.0	66.4	64.3	F
EB	Left Turn	30	26	85.3%	0.8	13.9	7.1	B
	Through	680	648	95.3%	1.2	8.8	1.7	A
	Right Turn	290	267	91.9%	1.4	11.4	2.6	B
	Subtotal	1,000	940	94.0%	1.9	9.7	1.5	A
WB	Left Turn	10	10	99.0%	0.0	9.5	11.5	A
	Through	770	797	103.6%	1.0	20.9	9.6	C
	Right Turn	30	28	92.3%	0.4	20.8	17.1	C
	Subtotal	810	835	103.1%	0.9	20.8	9.6	C
Total		1,910	1,884	98.6%	0.6	26.5	7.0	D

Intersection 60

El Camino Real/Ravenswood Ave

Signal

Direction	Movement	Volume (vph)		Percent Served	GEH	Total Delay (sec/veh)		
		Demand	Served			Average	Std. Dev.	LOS
NB	Left Turn	110	113	102.8%	0.3	72.8	8.3	E
	Through	1,240	1,204	97.1%	1.0	41.3	7.1	D
	Right Turn	690	566	82.0%	4.9	44.3	23.8	D
	Subtotal	2,040	1,883	92.3%	3.5	44.4	11.3	D
SB	Left Turn	200	239	119.5%	2.6	163.6	28.8	F
	Through	1,530	1,399	91.4%	3.4	57.1	10.2	E
	Right Turn	30	30	100.0%	0.0	53.3	19.4	D
	Subtotal	1,760	1,668	94.8%	2.2	71.5	13.0	E
EB	Left Turn	20	18	92.0%	0.4	297.0	112.8	F
	Through	440	397	90.2%	2.1	364.2	37.1	F
	Right Turn	70	76	109.0%	0.7	313.8	32.8	F
	Subtotal	530	492	92.8%	1.7	353.3	34.4	F
WB	Left Turn	551	569	103.2%	0.7	145.5	22.8	F
	Through	301	289	95.9%	0.7	148.5	27.7	F
	Right Turn	130	135	104.1%	0.5	31.4	10.7	C
	Subtotal	982	993	101.1%	0.3	128.4	9.5	F
Total		5,312	5,035	94.8%	3.9	99.1	8.9	F

Intersection 59

Alma Street/Ravenswood Ave

Side-street Stop

Direction	Movement	Volume (vph)		Percent Served	GEH	Total Delay (sec/veh)		
		Demand	Served			Average	Std. Dev.	LOS
NB	Left Turn	110	84	76.0%	2.7	344.9	82.9	F
	Through	10	9	88.0%	0.4	314.5	109.2	F
	Right Turn	80	73	90.6%	0.9	324.0	82.4	F
	Subtotal	200	165	82.5%	2.6	333.7	82.3	F
SB	Left Turn	10	11	114.0%	0.4	79.4	76.3	F
	Through	10	8	81.0%	0.6	77.4	70.6	F
	Right Turn	60	49	81.7%	1.5	71.5	52.8	F
	Subtotal	80	69	85.6%	1.3	72.3	54.2	F
EB	Left Turn	20	14	71.5%	1.4	57.3	46.6	F
	Through	950	699	73.5%	8.8	14.4	3.0	B
	Right Turn	320	264	82.5%	3.3	21.4	4.5	C
	Subtotal	1,290	977	75.7%	9.3	15.4	3.4	C
WB	Left Turn	50	100	199.8%	5.8	75.9	17.8	F
	Through	980	849	86.6%	4.3	70.0	15.6	F
	Right Turn	30	30	101.3%	0.1	48.5	24.5	E
	Subtotal	1,060	979	92.4%	2.5	69.8	15.5	F
Total		2,630	2,190	83.3%	9.0	65.3	8.7	F

Intersection 60

El Camino Real/Ravenswood Ave

Signal

Direction	Movement	Volume (vph)		Percent Served	GEH	Total Delay (sec/veh)		
		Demand	Served			Average	Std. Dev.	LOS
NB	Left Turn	190	173	91.1%	1.3	193.9	25.3	F
	Through	1,540	1,352	87.8%	4.9	173.8	18.2	F
	Right Turn	760	600	79.0%	6.1	395.1	33.0	F
	Subtotal	2,490	2,126	85.4%	7.6	243.7	14.9	F
SB	Left Turn	250	234	93.4%	1.1	231.0	29.0	F
	Through	1,250	1,040	83.2%	6.2	66.3	4.1	E
	Right Turn	60	51	85.3%	1.2	43.9	13.5	D
	Subtotal	1,560	1,324	84.9%	6.2	96.0	8.0	F
EB	Left Turn	50	37	73.6%	2.0	467.5	51.5	F
	Through	310	233	75.3%	4.6	512.9	48.9	F
	Right Turn	140	95	67.5%	4.2	562.9	48.1	F
	Subtotal	500	365	72.9%	6.5	521.4	44.5	F
WB	Left Turn	900	624	69.3%	10.0	75.0	6.2	E
	Through	320	248	77.4%	4.3	73.5	6.4	E
	Right Turn	80	97	120.9%	1.8	27.3	6.1	C
	Subtotal	1,302	969	74.4%	9.9	100.3	9.8	F
Total		5,852	4,783	81.7%	14.7	192.9	7.2	F

Intersection 63 Meadow Drive/Alma Street Signal

Direction	Movement	Volume (vph)		Percent Served	Total Delay (sec/veh)			
		Demand	Served		GEH	Average	Std. Dev.	LOS
NB	Left Turn	140	67	48.0%	7.2	93.3	17.2	F
	Through	2,070	1,065	51.4%	25.4	47.6	6.3	D
	Right Turn	70	36	51.9%	4.6	41.4	15.3	D
	Subtotal	2,280	1,168	51.2%	26.8	50.3	6.7	D
SB	Left Turn	60	40	66.5%	2.8	317.4	47.4	F
	Through	1,250	864	69.1%	11.9	236.6	76.8	F
	Right Turn	300	208	69.4%	5.8	178.4	43.5	F
	Subtotal	1,610	1,112	69.1%	13.5	228.8	66.5	F
EB	Left Turn	330	258	78.2%	4.2	272.6	5.8	F
	Through	190	126	66.3%	5.1	274.0	8.4	F
	Right Turn	170	129	76.0%	3.3	283.0	13.4	F
	Subtotal	690	513	74.4%	7.2	275.6	6.7	F
WB	Left Turn	140	115	82.1%	2.2	300.1	53.1	F
	Through	300	241	80.5%	3.6	276.3	27.2	F
	Right Turn	90	72	80.0%	2.0	252.9	27.3	F
	Subtotal	530	428	80.8%	4.6	280.6	33.8	F
Total		5,110	3,222	63.1%	29.3	178.4	19.0	F

Intersection 68 Alma Street/Charleston Road Signal

Direction	Movement	Volume (vph)		Percent Served	Total Delay (sec/veh)			
		Demand	Served		GEH	Average	Std. Dev.	LOS
NB	Left Turn	630	286	45.4%	16.1	798.6	45.6	F
	Through	1,540	690	44.8%	25.5	442.5	54.9	F
	Right Turn	150	61	40.5%	8.7	426.3	69.1	F
	Subtotal	2,320	1,037	44.7%	31.3	554.1	55.6	F
SB	Left Turn	130	92	70.5%	3.6	908.0	115.7	F
	Through	1,380	953	69.1%	12.5	197.0	23.5	F
	Right Turn	80	52	65.3%	3.4	129.2	24.0	F
	Subtotal	1,590	1,097	69.0%	13.5	265.8	25.1	F
EB	Left Turn	310	234	75.6%	4.6	114.2	5.3	F
	Through	570	429	75.2%	6.3	120.2	3.9	F
	Right Turn	320	238	74.3%	4.9	117.7	4.5	F
	Subtotal	1,200	901	75.0%	9.2	118.0	1.8	F
WB	Left Turn	100	53	52.7%	5.4	219.1	31.2	F
	Through	440	249	56.6%	10.3	238.4	30.5	F
	Right Turn	380	210	55.2%	9.9	223.6	39.9	F
	Subtotal	920	512	55.6%	15.3	229.2	32.0	F
Total		6,030	3,546	58.8%	35.9	307.3	12.9	F

Intersection 67 Meadow Drive/Park Ave Side-street Stop

Direction	Movement	Volume (vph)		Percent Served	Total Delay (sec/veh)			
		Demand	Served		GEH	Average	Std. Dev.	LOS
NB	Left Turn	10	4	41.0%	2.2	889.4	785.7	F
	Through							
	Right Turn	50	20	40.4%	5.0	1682.7	330.0	F
	Subtotal	60	24	40.5%	5.5	1364.6	310.8	F
SB	Left Turn							
	Through							
	Right Turn	5	4	82.0%	0.4	5.0	1.0	A
	Subtotal	5	4	82.0%	0.4	5.0	1.0	A
EB	Left Turn							
	Through	640	493	77.0%	6.2	220.6	8.2	F
	Right Turn	10	8	75.0%	0.8	147.3	102.8	F
	Subtotal	650	500	76.9%	6.3	218.9	8.9	F
WB	Left Turn							
	Through	610	426	69.9%	8.1	1.0	0.3	A
	Right Turn	130	91	69.7%	3.8	1.9	0.8	A
	Subtotal	740	517	69.9%	8.9	1.2	0.3	A
Total		1,455	1,045	71.8%	11.6	131.3	19.4	F

Intersection 63 Meadow Drive/Alma Street Signal

Direction	Movement	Volume (vph)		Percent Served	Total Delay (sec/veh)			
		Demand	Served		GEH	Average	Std. Dev.	LOS
NB	Left Turn	80	50	62.5%	3.7	80.0	15.4	E
	Through	1,560	1,012	64.9%	15.3	31.0	4.9	C
	Right Turn	80	54	68.0%	3.1	25.8	8.8	C
	Subtotal	1,720	1,117	64.9%	16.0	33.2	5.0	C
SB	Left Turn	70	54	77.3%	2.0	506.9	53.3	F
	Through	1,690	1,257	74.4%	11.3	259.5	31.9	F
	Right Turn	320	233	72.7%	5.3	223.4	22.9	F
	Subtotal	2,080	1,543	74.2%	12.6	263.9	31.9	F
EB	Left Turn	220	151	68.7%	5.1	238.9	7.2	F
	Through	320	222	69.3%	6.0	235.9	5.2	F
	Right Turn	100	70	70.0%	3.3	227.4	12.8	F
	Subtotal	640	443	69.2%	8.5	235.1	2.7	F
WB	Left Turn	90	81	90.3%	0.9	239.9	32.9	F
	Through	300	280	93.3%	1.2	244.4	36.4	F
	Right Turn	80	75	93.3%	0.6	224.3	39.5	F
	Subtotal	470	436	92.7%	1.6	240.0	35.6	F
Total		4,910	3,539	72.1%	21.1	184.6	8.6	F

Intersection 68 Alma Street/Charleston Road Signal

Direction	Movement	Volume (vph)		Percent Served	Total Delay (sec/veh)			
		Demand	Served		GEH	Average	Std. Dev.	LOS
NB	Left Turn	470	317	67.5%	7.7	270.5	28.2	F
	Through	1,510	1,000	66.3%	14.4	232.5	19.6	F
	Right Turn	80	56	70.4%	2.9	235.4	22.3	F
	Subtotal	2,060	1,374	66.7%	16.6	243.6	17.9	F
SB	Left Turn	290	215	74.1%	4.7	169.0	42.2	F
	Through	1,270	968	76.2%	9.0	121.6	20.4	F
	Right Turn	360	270	75.1%	5.0	100.9	15.9	F
	Subtotal	1,920	1,454	75.7%	11.4	124.5	22.2	F
EB	Left Turn	100	60	60.3%	4.4	192.8	6.9	F
	Through	690	413	59.9%	11.8	198.1	8.7	F
	Right Turn	610	356	58.4%	11.5	194.7	6.5	F
	Subtotal	1,400	830	59.3%	17.1	196.2	7.0	F
WB	Left Turn	330	162	49.1%	10.7	202.6	32.3	F
	Through	680	343	50.4%	14.9	207.6	21.1	F
	Right Turn	110	53	48.4%	6.3	197.4	23.9	F
	Subtotal	1,120	558	49.8%	19.4	205.4	22.8	F
Total		6,500	4,216	64.9%	31.2	188.1	17.4	F

Intersection 67 Meadow Drive/Park Ave Side-street Stop

Direction	Movement	Volume (vph)		Percent Served	Total Delay (sec/veh)			
		Demand	Served		GEH	Average	Std. Dev.	LOS
NB	Left Turn	10	7	73.0%	0.9	548.1	469.0	F
	Through							
	Right Turn	30	25	82.3%	1.0	704.0	345.7	F
	Subtotal	40	32	80.0%	1.3	659.4	367.3	F
SB	Left Turn							
	Through							
	Right Turn	5	17	342.0%	3.6	5.3	0.5	A
	Subtotal	5	17	342.0%	3.6	5.3	0.5	A
EB	Left Turn							
	Through	610	418	68.5%	8.5	172.3	8.3	F
	Right Turn	30	20	66.7%	2.0	157.8	22.3	F
	Subtotal	640	438	68.4%	8.7	171.6	8.0	F
WB	Left Turn							
	Through	560	448	79.9%	5.0	1.3	0.6	A
	Right Turn	140	115	82.3%	2.2	2.4	1.0	A
	Subtotal	700	563	80.4%	5.5	1.5	0.6	A
Total		1,385	1,049	75.8%	9.6	91.1	9.8	F

Intersection 66

Alma Street/Churchill Street

Signal

Direction	Movement	Volume (vph)		Percent Served	GEH	Total Delay (sec/veh)		
		Demand	Served			Average	Std. Dev.	LOS
NB	Left Turn	310	208	67.1%	6.3	495.3	122.6	F
	Through	1,900	1,357	71.4%	13.4	143.2	18.4	F
	Right Turn	30	21	69.0%	1.8	106.7	34.2	F
	Subtotal	2,240	1,586	70.8%	15.0	193.8	26.2	F
SB	Left Turn	10	11	108.0%	0.2	146.6	96.5	F
	Through	980	972	99.2%	0.2	46.2	3.1	D
	Right Turn	310	307	98.9%	0.2	49.8	9.6	D
	Subtotal	1,300	1,290	99.2%	0.3	48.0	4.3	D
EB	Left Turn	60	60	100.2%	0.0	82.8	17.9	F
	Through	150	151	100.6%	0.1	84.5	13.2	F
	Right Turn	130	129	99.3%	0.1	30.2	8.9	C
	Subtotal	340	340	100.0%	0.0	63.9	13.9	E
WB	Left Turn	170	168	98.8%	0.2	395.1	167.6	F
	Through	75	48	63.9%	3.5	387.6	144.2	F
	Right Turn	10	10	98.0%	0.1	417.1	231.6	F
	Subtotal	255	226	88.5%	1.9	394.3	165.2	F
Total		4,135	3,441	83.2%	11.3	134.6	11.9	F

Intersection 66

Alma Street/Churchill Street

Signal

Direction	Movement	Volume (vph)		Percent Served	GEH	Total Delay (sec/veh)		
		Demand	Served			Average	Std. Dev.	LOS
NB	Left Turn	180	134	74.6%	3.7	587.6	124.8	F
	Through	1,100	965	87.7%	4.2	133.1	33.5	F
	Right Turn	70	57	80.7%	1.7	139.6	39.8	F
	Subtotal	1,350	1,156	85.6%	5.5	189.3	41.8	F
SB	Left Turn	30	28	93.0%	0.4	255.0	50.0	F
	Through	1,710	1,535	89.8%	4.3	169.1	5.7	F
	Right Turn	140	124	88.7%	1.4	159.9	9.5	F
	Subtotal	1,880	1,687	89.7%	4.6	169.7	5.6	F
EB	Left Turn	280	200	71.3%	5.2	203.8	21.1	F
	Through	180	118	65.4%	5.1	203.4	34.1	F
	Right Turn	420	305	72.7%	6.0	196.5	17.7	F
	Subtotal	880	623	70.7%	9.4	200.4	21.5	F
WB	Left Turn	110	95	86.3%	1.5	321.5	48.2	F
	Through	150	117	77.7%	2.9	326.6	42.1	F
	Right Turn	20	15	72.5%	1.3	313.0	65.8	F
	Subtotal	280	226	80.7%	3.4	323.6	44.6	F
Total		4,390	3,691	84.1%	11.0	191.3	12.7	F

Intersection 70

Rengstorff/Central Expressway

Signal

Direction	Movement	Volume (vph)		Percent Served	Total Delay (sec/veh)		
		Demand	Served		Average	Std. Dev.	LOS
NB	Left Turn	460	320	69.5%	139.1	5.1	F
	Through	890	619	69.5%	145.1	7.7	F
	Right Turn	100	70	69.7%	139.0	15.2	F
	Subtotal	1,450	1,008	69.5%	143.0	5.4	F
SB	Left Turn	60	41	68.8%	240.3	33.6	F
	Through	740	527	71.2%	247.1	15.2	F
	Right Turn	140	96	68.3%	242.3	24.6	F
	Subtotal	940	664	70.6%	246.2	14.0	F
EB	Left Turn	160	145	90.7%	272.3	29.8	F
	Through	1,280	1,161	90.7%	189.4	6.0	F
	Right Turn	290	263	90.5%	172.7	6.9	F
	Subtotal	1,730	1,569	90.7%	194.3	6.4	F
WB	Left Turn	140	87	62.1%	649.7	126.1	F
	Through	1,680	1,077	64.1%	307.7	36.9	F
	Right Turn	460	300	65.2%	185.8	15.4	F
	Subtotal	2,280	1,464	64.2%	306.3	39.5	F
Total		6,400	4,705	73.5%	225.3	9.6	F

Intersection 71

Moffett/Central Expressway

Signal

Direction	Movement	Volume (vph)		Percent Served	Total Delay (sec/veh)		
		Demand	Served		Average	Std. Dev.	LOS
NB	Left Turn	240	163	67.8%	84.4	10.6	F
	Through	640	472	73.8%	90.9	9.9	F
	Right Turn	240	163	67.8%	95.1	14.9	F
	Subtotal	1,120	798	71.2%	90.5	8.9	F
SB	Left Turn	120	68	56.3%	270.4	34.5	F
	Through	650	386	59.4%	282.5	17.2	F
	Right Turn	220	130	59.1%	262.4	29.4	F
	Subtotal	990	584	59.0%	275.9	16.0	F
EB	Left Turn	300	271	90.4%	189.5	18.8	F
	Through	1,440	1,357	94.2%	111.0	11.3	F
	Right Turn	170	156	92.0%	68.8	8.8	E
	Subtotal	1,910	1,784	93.4%	120.4	10.5	F
WB	Left Turn	150	71	47.0%	517.6	27.6	F
	Through	1,960	1,027	52.4%	441.3	13.4	F
	Right Turn	290	147	50.8%	419.8	17.3	F
	Subtotal	2,400	1,244	51.9%	442.8	12.8	F
Total		6,420	4,411	68.7%	213.9	9.9	F

Intersection 70

Rengstorff/Central Expressway

Signal

Direction	Movement	Volume (vph)		Percent Served	Total Delay (sec/veh)		
		Demand	Served		Average	Std. Dev.	LOS
NB	Left Turn	250	214	85.6%	93.5	12.2	F
	Through	680	576	84.7%	103.7	14.7	F
	Right Turn	130	108	82.8%	107.4	18.9	F
	Subtotal	1,060	898	84.7%	101.7	14.0	F
SB	Left Turn	570	346	60.7%	189.7	16.8	F
	Through	940	598	63.6%	180.4	15.7	F
	Right Turn	60	39	64.7%	185.4	36.3	F
	Subtotal	1,570	983	62.6%	184.0	16.0	F
EB	Left Turn	470	235	49.9%	550.8	40.2	F
	Through	1,250	629	50.3%	217.8	14.8	F
	Right Turn	330	168	50.9%	184.2	23.0	F
	Subtotal	2,050	1,031	50.3%	291.4	25.0	F
WB	Left Turn	160	109	68.4%	552.2	114.1	F
	Through	1,390	1,016	73.1%	288.9	27.4	F
	Right Turn	150	112	74.8%	139.9	12.6	F
	Subtotal	1,700	1,238	72.8%	306.9	32.3	F
Total		6,380	4,150	65.0%	220.2	4.7	F

Intersection 71

Moffett/Central Expressway

Signal

Direction	Movement	Volume (vph)		Percent Served	Total Delay (sec/veh)		
		Demand	Served		Average	Std. Dev.	LOS
NB	Left Turn	160	105	65.5%	74.2	7.5	E
	Through	850	556	65.4%	81.4	10.4	F
	Right Turn	180	115	63.7%	81.0	12.4	F
	Subtotal	1,190	775	65.2%	80.5	9.5	F
SB	Left Turn	670	300	44.7%	273.3	38.1	F
	Through	520	251	48.2%	254.0	34.6	F
	Right Turn	260	124	47.7%	237.7	34.1	F
	Subtotal	1,450	674	46.5%	260.1	33.6	F
EB	Left Turn	710	295	41.5%	515.1	65.0	F
	Through	1,370	599	43.7%	269.3	27.9	F
	Right Turn	240	99	41.4%	210.8	31.1	F
	Subtotal	2,320	992	42.8%	331.6	39.9	F
WB	Left Turn	310	151	48.5%	622.7	63.5	F
	Through	1,630	807	49.5%	289.4	37.7	F
	Right Turn	150	74	49.3%	252.2	31.5	F
	Subtotal	2,090	1,031	49.3%	333.4	43.3	F
Total		7,050	3,473	49.3%	263.7	10.0	F

VISSIM Post-Processor
Average Results from 10 Runs
Volume and Delay by Movement

Caltrain Electrification
2040 Project
AM Peak Hour

Intersection 75

Mary/Evelyn

Signal

Direction	Movement	Volume (vph)		Percent Served	Total Delay (sec/veh)		
		Demand	Served		Average	Std. Dev.	LOS
NB	Left Turn	440	352	79.9%	135.0	27.8	F
	Through	1,550	1,276	82.3%	105.7	7.4	F
	Right Turn	60	50	83.5%	90.1	21.4	F
	Subtotal	2,050	1,678	81.8%	111.4	4.3	F
SB	Left Turn	130	130	99.6%	95.8	18.0	F
	Through	730	716	98.1%	76.5	9.8	E
	Right Turn	290	291	100.3%	103.2	15.2	F
	Subtotal	1,150	1,137	98.9%	85.8	9.8	F
EB	Left Turn	360	295	81.9%	261.9	26.5	F
	Through	280	231	82.5%	43.7	5.1	D
	Right Turn	80	61	76.4%	39.0	12.1	D
	Subtotal	720	587	81.5%	155.5	23.9	F
WB	Left Turn	80	71	88.3%	82.4	16.4	F
	Through	320	292	91.2%	102.5	11.3	F
	Right Turn	490	447	91.2%	126.7	10.9	F
	Subtotal	890	810	91.0%	114.5	9.3	F
Total		4,810	4,211	87.5%	110.2	4.5	F

VISSIM Post-Processor
Average Results from 10 Runs
Volume and Delay by Movement

Catrain Electrification
2040 Project
PM Peak Hour

Intersection 75

Mary/Evelyn

Signal

Direction	Movement	Volume (vph)		Percent Served	Total Delay (sec/veh)		
		Demand	Served		Average	Std. Dev.	LOS
NB	Left Turn	50	50	99.0%	50.3	7.9	D
	Through	580	596	102.8%	57.7	13.7	E
	Right Turn	50	54	107.0%	42.3	25.1	D
	Subtotal	680	699	102.8%	56.0	13.4	E
SB	Left Turn	390	224	57.5%	100.8	9.8	F
	Through	2,180	1,318	60.5%	114.4	13.4	F
	Right Turn	590	356	60.4%	137.7	18.8	F
	Subtotal	3,160	1,899	60.1%	117.2	12.6	F
EB	Left Turn	320	238	74.3%	304.4	18.3	F
	Through	690	510	73.9%	69.7	4.9	E
	Right Turn	180	130	72.1%	62.0	7.2	E
	Subtotal	1,190	877	73.7%	130.3	9.6	F
WB	Left Turn	70	74	105.4%	54.9	8.0	D
	Through	280	286	102.0%	37.5	4.1	D
	Right Turn	150	148	98.5%	24.3	4.6	C
	Subtotal	500	507	101.4%	36.8	2.8	D
Total		5,530	3,982	72.0%	96.8	4.7	F

2040 Project Mitigated



Intersection 1

4th Street/King Street

Signal

Direction	Movement	Volume (vph)		Percent Served	GEH	Total Delay (sec/veh)		
		Demand	Served			Average	Std. Dev.	LOS
NB	Left Turn	10	9	91.0%	0.3	61.7	35.4	E
	Through	60	111	185.7%	5.6	30.9	5.9	C
	Right Turn	40	50	125.8%	1.5	16.3	8.3	B
	Subtotal	110	171	155.3%	5.1	27.7	5.2	C
SB	Left Turn	130	112	85.8%	1.7	79.3	13.8	E
	Through	460	424	92.1%	1.7	59.3	5.4	E
	Right Turn	270	237	87.8%	2.1	40.0	7.0	D
	Subtotal	860	772	89.8%	3.1	56.0	4.2	E
EB	Left Turn	100	71	71.0%	3.1	374.1	19.3	F
	Through	1,790	1,349	75.4%	11.1	212.5	14.2	F
	Right Turn	10	8	84.0%	0.5	126.0	56.9	F
	Subtotal	1,900	1,429	75.2%	11.6	219.6	14.1	F
WB	Left Turn	40	41	103.5%	0.2	105.7	37.0	F
	Through	850	934	109.8%	2.8	83.0	18.1	F
	Right Turn	30	69	230.0%	5.5	59.6	18.9	E
	Subtotal	920	1,044	113.5%	4.0	82.5	18.6	F
Total		3,790	3,416	90.1%	6.2	132.4	5.6	F

Intersection 2

4th Street/Townsend Street

Signal

Direction	Movement	Volume (vph)		Percent Served	GEH	Total Delay (sec/veh)		
		Demand	Served			Average	Std. Dev.	LOS
NB	Left Turn							
	Through	30	27	88.7%	0.6	26.9	6.7	C
	Right Turn	160	161	100.9%	0.1	14.7	4.0	B
	Subtotal	190	188	98.9%	0.1	16.8	4.5	B
SB	Left Turn							
	Through	530	541	102.0%	0.5	341.5	32.2	F
	Right Turn	80	62	78.0%	2.1	507.8	84.0	F
	Subtotal	610	603	98.9%	0.3	360.6	35.3	F
EB	Left Turn							
	Through	380	414	109.0%	1.7	55.2	20.2	E
	Right Turn	160	153	95.7%	0.6	170.5	87.9	F
	Subtotal	540	567	105.1%	1.2	91.8	38.3	F
WB	Left Turn	170	165	97.3%	0.4	125.3	72.5	F
	Through	220	228	103.5%	0.5	18.0	9.3	B
	Right Turn							
	Subtotal	390	393	100.8%	0.2	69.5	40.9	E
Total		1,730	1,752	101.3%	0.5	168.2	18.8	F

Intersection 5

7th Street/16th Street

Signal

Direction	Movement	Volume (vph)		Percent Served	GEH	Total Delay (sec/veh)		
		Demand	Served			Average	Std. Dev.	LOS
NB	Left Turn	390	209	53.6%	10.5	174.7	38.1	F
	Through	250	317	126.7%	4.0	172.7	31.5	F
	Right Turn	110	91	82.5%	1.9	133.9	24.4	F
	Subtotal	750	616	82.2%	5.1	167.9	30.6	F
SB	Left Turn	100	129	128.6%	2.7	80.3	19.2	F
	Through	130	98	75.5%	3.0	70.8	15.9	E
	Right Turn	40	40	100.5%	0.0	46.9	14.8	D
	Subtotal	270	267	98.9%	0.2	71.9	15.6	E
EB	Left Turn	40	33	83.3%	1.1	162.9	44.8	F
	Through	590	459	77.8%	5.7	194.2	31.1	F
	Right Turn	130	102	78.2%	2.6	178.9	35.8	F
	Subtotal	760	594	78.2%	6.4	189.3	28.2	F
WB	Left Turn	80	81	101.6%	0.1	64.6	10.4	E
	Through	430	438	101.7%	0.4	62.9	6.3	E
	Right Turn	170	169	99.5%	0.1	23.6	3.0	C
	Subtotal	680	688	101.2%	0.3	53.5	6.1	D
Total		2,460	2,165	88.0%	6.1	127.8	8.2	F

Intersection 6

Owens Street/16th Street

Signal

Direction	Movement	Volume (vph)		Percent Served	GEH	Total Delay (sec/veh)		
		Demand	Served			Average	Std. Dev.	LOS
NB	Left Turn							
	Through							
	Right Turn							
	Subtotal							
SB	Left Turn	60	61	101.2%	0.1	19.5	2.7	B
	Through							
	Right Turn	110	109	99.0%	0.1	7.3	2.0	A
	Subtotal	170	170	99.8%	0.0	11.6	1.9	B
EB	Left Turn	250	196	78.4%	3.6	21.8	2.5	C
	Through	630	491	78.0%	5.9	4.4	1.0	A
	Right Turn							
	Subtotal	880	687	78.1%	6.9	9.3	1.4	A
WB	Left Turn							
	Through	570	571	100.2%	0.1	11.9	1.7	B
	Right Turn	120	117	97.8%	0.2	10.6	2.2	B
	Subtotal	690	689	99.8%	0.0	11.7	1.4	B
Total		1,740	1,546	88.8%	4.8	10.7	0.8	B

Intersection 6

7th Street/16th Street

Signal

Direction	Movement	Volume (vph)		Percent Served	GEH	Total Delay (sec/veh)		
		Demand	Served			Average	Std. Dev.	LOS
NB	Left Turn	140	139	99.4%	0.1	109.3	22.0	F
	Through	340	336	98.9%	0.2	107.3	29.0	F
	Right Turn	50	49	97.0%	0.2	81.0	24.3	F
	Subtotal	530	524	98.9%	0.3	104.7	25.9	F
SB	Left Turn	50	83	166.8%	4.1	88.1	14.1	F
	Through	200	200	99.8%	0.0	83.2	10.1	F
	Right Turn	80	49	61.8%	3.8	73.9	9.9	E
	Subtotal	330	332	100.7%	0.1	83.4	7.4	F
EB	Left Turn	80	70	87.1%	1.2	158.1	18.6	F
	Through	540	478	88.5%	2.8	183.9	21.9	F
	Right Turn	80	73	90.9%	0.8	175.0	23.5	F
	Subtotal	700	620	88.6%	3.1	179.9	19.7	F
WB	Left Turn	180	157	86.9%	1.8	120.7	28.4	F
	Through	730	625	85.7%	4.0	115.0	13.6	F
	Right Turn	370	323	87.3%	2.5	68.5	11.7	E
	Subtotal	1,280	1,105	86.3%	5.1	101.8	11.5	F
Total		2,840	2,581	90.9%	5.0	118.3	8.1	F

Intersection 6

Owens Street/16th Street

Signal

Direction	Movement	Volume (vph)		Percent Served	GEH	Total Delay (sec/veh)		
		Demand	Served			Average	Std. Dev.	LOS
NB	Left Turn							
	Through							
	Right Turn							
	Subtotal							
SB	Left Turn	100	100	100.3%	0.0	72.1	22.3	E
	Through							
	Right Turn	230	211	91.8%	1.3	154.3	33.9	F
	Subtotal	330	311	94.4%	1.0	130.5	30.6	F
EB	Left Turn	110	105	95.5%	0.5	60.1	13.4	E
	Through	560	514	91.8%	2.0	10.5	4.1	B
	Right Turn							
	Subtotal	670	619	92.4%	2.0	19.4	4.4	B
WB	Left Turn							
	Through	1,050	905	86.2%	4.6	121.0	16.7	F
	Right Turn	90	75	83.7%	1.6	119.7	25.8	F
	Subtotal	1,140	980	86.0%	4.9	121.0	16.9	F
Total		2,140	1,911	89.3%	5.1	89.1	11.3	F

VISSIM Post-Processor
Average Results from 10 Runs
Volume and Delay by Movement

Caltrain Electrification
2040 Project Mitigated
AM Peak Hour

Intersection 18

California/Broadway

Signal

Direction	Movement	Volume (vph)		Percent Served	Total Delay (sec/veh)		
		Demand	Served		Average	Std. Dev.	LOS
NB	Left Turn	100	100	100.0%	55.2	6.6	E
	Through	410	414	100.9%	74.4	8.0	E
	Right Turn	500	505	101.0%	22.7	3.8	C
	Subtotal	1,010	1,019	100.8%	46.5	3.9	D
SB	Left Turn	440	233	52.9%	163.4	9.1	F
	Through	540	294	54.4%	187.6	14.6	F
	Right Turn	40	21	53.3%	166.2	20.4	F
	Subtotal	1,020	548	53.7%	177.2	11.9	F
EB	Left Turn	10	9	89.0%	201.3	88.3	F
	Through	400	389	97.2%	206.7	17.5	F
	Right Turn	40	42	106.0%	197.2	37.5	F
	Subtotal	450	440	97.8%	205.8	18.3	F
WB	Left Turn	280	254	90.8%	15.5	1.2	B
	Through	310	293	94.5%	8.5	1.6	A
	Right Turn	300	296	98.5%	2.3	0.8	A
	Subtotal	890	843	94.7%	8.4	0.8	A
Total		3,370	2,849	84.5%	86.9	3.6	F

Intersection 19

Carolan/Broadway

Signal

Direction	Movement	Volume (vph)		Percent Served	Total Delay (sec/veh)		
		Demand	Served		Average	Std. Dev.	LOS
NB	Left Turn	210	183	86.9%	245.1	50.7	F
	Through	1	8	760.0%	206.8	94.8	F
	Right Turn	570	518	90.8%	96.4	9.0	F
	Subtotal	781	708	90.6%	134.1	10.5	F
SB	Left Turn						
	Through						
	Right Turn						
	Subtotal						
EB	Left Turn	10	9	87.0%	21.3	17.7	C
	Through	1,160	974	84.0%	4.8	0.6	A
	Right Turn	170	144	84.7%	4.0	2.0	A
	Subtotal	1,340	1,127	84.1%	4.8	0.5	A
WB	Left Turn	450	413	91.7%	165.6	7.9	F
	Through	680	662	97.4%	65.7	18.4	E
	Right Turn	10	10	95.0%	49.5	39.7	D
	Subtotal	1,140	1,084	95.1%	107.0	13.9	F
Total		3,261	2,919	89.5%	75.2	5.9	E

Intersection 45

El Camino Real/Whipple Road

Signal

Direction	Movement	Volume (vph)		Percent Served	Total Delay (sec/veh)		
		Demand	Served		Average	Std. Dev.	LOS
NB	Left Turn	80	66	82.3%	132.5	15.1	F
	Through	1,210	993	82.1%	111.3	6.0	F
	Right Turn	450	374	83.2%	81.1	8.6	F
	Subtotal	1,740	1,433	82.4%	103.7	6.3	F
SB	Left Turn	540	482	89.3%	202.5	11.2	F
	Through	830	733	88.3%	83.9	9.1	F
	Right Turn	120	108	90.2%	75.5	9.9	E
	Subtotal	1,490	1,323	88.8%	128.8	8.6	F
EB	Left Turn	170	166	97.5%	158.3	18.1	F
	Through	470	469	99.7%	155.6	18.7	F
	Right Turn	110	103	93.3%	148.2	23.0	F
	Subtotal	750	737	98.2%	155.2	17.9	F
WB	Left Turn	490	481	98.1%	56.7	9.8	E
	Through	300	293	97.6%	46.2	7.6	D
	Right Turn	210	208	99.2%	14.0	4.5	B
	Subtotal	1,000	982	98.2%	44.8	7.8	D
Total		4,980	4,475	89.9%	106.7	5.5	F

Intersection 62

Palo Alto/Alma

Side-street Stop

Direction	Movement	Volume (vph)		Percent Served	Total Delay (sec/veh)		
		Demand	Served		Average	Std. Dev.	LOS
NB	Left Turn						
	Through						
	Right Turn						
	Subtotal						
SB	Left Turn	90	86	95.9%	26.8	10.4	D
	Through						
	Right Turn	30	34	111.7%	23.9	13.1	C
	Subtotal	120	120	99.8%	25.7	10.3	D
EB	Left Turn						
	Through	600	575	95.8%	5.0	1.0	A
	Right Turn						
	Subtotal	600	575	95.8%	5.0	1.0	A
WB	Left Turn						
	Through	760	757	99.6%	8.4	1.6	A
	Right Turn	20	20	101.5%	6.9	9.1	A
	Subtotal	780	777	99.7%	8.3	1.7	A
Total		1,500	1,472	98.1%	10.1	1.7	B

VISSIM Post-Processor
Average Results from 10 Runs
Volume and Delay by Movement

Caltrain Electrification
2040 Project Conditions
AM Peak Hour

Intersection 64

El Camino Real/Sand Hill-Palo Alto

Signal

Direction	Movement	Volume (vph)		Percent Served	Total Delay (sec/veh)		
		Demand	Served		Average	Std. Dev.	LOS
NB	Left Turn	140	141	100.6%	87.0	20.0	F
	Through	1,290	1,287	99.8%	79.0	20.9	E
	Right Turn	50	50	100.8%	42.4	25.2	D
	Subtotal	1,480	1,478	99.9%	78.5	20.7	E
SB	Left Turn	550	524	95.2%	280.0	32.4	F
	Through	1,440	1,448	100.5%	43.8	4.2	D
	Right Turn	660	653	99.0%	16.6	3.2	B
	Subtotal	2,650	2,625	99.1%	84.4	7.9	F
EB	Left Turn	280	284	101.5%	60.0	5.1	E
	Through						
	Right Turn	230	223	97.0%	10.9	2.2	B
	Subtotal	510	507	99.5%	39.4	3.9	D
WB	Left Turn						
	Through						
	Right Turn	790	792	100.2%	7.0	1.3	A
	Subtotal	790	792	100.2%	7.0	1.3	A
Total		5,430	5,402	99.5%	67.5	6.8	E

Intersection 45

El Camino Real/Whipple Road

Signal

Direction	Movement	Volume (vph)		Percent Served	Total Delay (sec/veh)		
		Demand	Served		Average	Std. Dev.	LOS
NB	Left Turn	100	99	99.4%	97.0	17.9	F
	Through	1,320	1,306	98.9%	64.6	15.6	E
	Right Turn	260	253	97.5%	49.4	13.6	D
	Subtotal	1,680	1,658	98.7%	63.8	15.2	E
SB	Left Turn	410	397	96.8%	189.9	28.3	F
	Through	1,380	1,301	94.3%	68.6	7.1	E
	Right Turn	110	107	97.1%	64.1	10.0	E
	Subtotal	1,900	1,805	95.0%	96.7	10.4	F
EB	Left Turn	180	150	83.4%	277.7	21.1	F
	Through	340	291	85.6%	282.5	9.7	F
	Right Turn	80	66	81.9%	268.9	20.1	F
	Subtotal	600	507	84.5%	279.2	10.4	F
WB	Left Turn	350	353	100.9%	40.4	5.2	D
	Through	450	446	99.0%	39.5	4.5	D
	Right Turn	330	326	98.7%	18.2	3.9	B
	Subtotal	1,130	1,124	99.5%	33.2	2.6	C
Total		5,310	5,094	95.9%	90.5	6.1	F

Intersection 62

Palo Alto/Alma

Side-street Stop

Direction	Movement	Volume (vph)		Percent Served	Total Delay (sec/veh)		
		Demand	Served		Average	Std. Dev.	LOS
NB	Left Turn						
	Through						
	Right Turn						
	Subtotal						
SB	Left Turn	10	10	103.0%	19.3	10.1	C
	Through						
	Right Turn	70	67	95.6%	30.0	7.9	D
	Subtotal	80	77	96.5%	28.8	6.7	D
EB	Left Turn						
	Through	670	613	91.5%	5.8	1.3	A
	Right Turn						
	Subtotal	670	613	91.5%	5.8	1.3	A
WB	Left Turn						
	Through	760	759	99.9%	13.2	1.6	B
	Right Turn	170	166	97.8%	10.2	2.5	B
	Subtotal	930	925	99.5%	12.6	1.2	B
Total		1,680	1,615	96.2%	11.6	0.9	B

Intersection 64

El Camino Real/Sand Hill-Palo Alto

Signal

Direction	Movement	Volume (vph)		Percent Served	Total Delay (sec/veh)		
		Demand	Served		Average	Std. Dev.	LOS
NB	Left Turn	150	125	83.5%	267.9	10.9	F
	Through	1,600	1,315	82.2%	267.0	10.5	F
	Right Turn	160	131	81.9%	226.1	10.7	F
	Subtotal	1,910	1,571	82.2%	263.8	9.4	F
SB	Left Turn	510	484	94.8%	241.2	78.3	F
	Through	1,540	1,515	98.4%	42.9	5.2	D
	Right Turn	290	284	98.1%	14.0	2.4	B
	Subtotal	2,340	2,283	97.6%	84.2	19.2	F
EB	Left Turn	790	679	85.9%	98.3	5.3	F
	Through						
	Right Turn	260	223	85.6%	46.0	6.0	D
	Subtotal	1,050	901	85.8%	86.2	5.1	F
WB	Left Turn						
	Through						
	Right Turn	830	826	99.6%	7.7	1.6	A
	Subtotal	830	826	99.6%	7.7	1.6	A
Total		6,130	5,581	91.1%	122.1	7.5	F

VISSIM Post-Processor
Average Results from 10 Runs
Volume and Delay by Movement

Caltrain Electrification
2040 Project Mitigated
AM Peak Hour

Intersection 66

Alma Street/Churchill Street

Signal

Direction	Movement	Volume (vph)		Percent Served	GEH	Total Delay (sec/veh)		
		Demand	Served			Average	Std. Dev.	LOS
NB	Left Turn	310	263	84.8%	2.8	196.0	24.1	F
	Through	1,900	1,678	88.3%	5.2	111.9	9.2	F
	Right Turn	30	29	97.7%	0.1	112.4	14.6	F
	Subtotal	2,240	1,971	88.0%	5.9	123.1	11.6	F
SB	Left Turn	10	11	106.0%	0.2	265.6	90.1	F
	Through	980	975	99.5%	0.2	71.0	46.9	E
	Right Turn	310	308	99.3%	0.1	79.0	44.5	E
	Subtotal	1,300	1,294	99.5%	0.2	74.6	45.9	E
EB	Left Turn	60	60	100.2%	0.0	93.6	21.3	F
	Through	150	150	100.2%	0.0	93.2	16.8	F
	Right Turn	130	129	99.2%	0.1	39.8	13.3	D
	Subtotal	340	339	99.8%	0.0	73.8	17.9	E
WB	Left Turn	170	161	94.7%	0.7	438.1	173.7	F
	Through	75	47	62.3%	3.6	467.3	199.3	F
	Right Turn	10	9	91.0%	0.3	426.5	158.9	F
	Subtotal	255	217	85.0%	2.5	438.9	170.0	F
Total		4,135	3,820	92.4%	5.0	117.0	15.3	F

Intersection 63

Alma Street/Meadow Drive

Signal

Direction	Movement	Volume (vph)		Percent Served	GEH	Total Delay (sec/veh)		
		Demand	Served			Average	Std. Dev.	LOS
NB	Left Turn	140	68	48.6%	7.0	88.2	16.9	F
	Through	2,070	1,073	51.8%	25.2	44.5	7.1	D
	Right Turn	70	38	54.4%	4.3	41.7	13.4	D
	Subtotal	2,280	1,179	51.7%	26.5	46.9	7.0	D
SB	Left Turn	60	37	61.7%	3.3	354.0	100.0	F
	Through	1,250	859	68.7%	12.1	242.5	97.5	F
	Right Turn	300	207	69.0%	5.8	180.8	61.0	F
	Subtotal	1,610	1,103	68.5%	13.8	235.7	91.6	F
EB	Left Turn	330	257	77.7%	4.3	267.2	4.1	F
	Through	190	125	65.5%	5.2	268.6	9.6	F
	Right Turn	170	131	77.0%	3.2	277.3	33.4	F
	Subtotal	690	512	74.2%	7.3	270.1	11.5	F
WB	Left Turn	140	117	83.4%	2.0	295.9	39.8	F
	Through	300	243	80.9%	3.5	273.3	18.3	F
	Right Turn	90	69	76.8%	2.3	256.7	29.2	F
	Subtotal	530	429	80.8%	4.6	277.4	25.5	F
Total		5,110	3,222	63.1%	29.2	177.6	28.7	F

Intersection 68

Alma Street/Charleston Road

Signal

Direction	Movement	Volume (vph)		Percent Served	GEH	Total Delay (sec/veh)		
		Demand	Served			Average	Std. Dev.	LOS
NB	Left Turn	630	287	45.5%	16.0	805.7	50.1	F
	Through	1,540	709	46.1%	24.8	432.5	52.7	F
	Right Turn	150	65	43.3%	8.2	405.9	51.3	F
	Subtotal	2,320	1,061	45.7%	30.6	551.4	60.1	F
SB	Left Turn	130	91	70.3%	3.7	832.8	98.4	F
	Through	1,380	949	68.8%	12.6	211.6	32.6	F
	Right Turn	80	54	66.9%	3.2	126.2	21.5	F
	Subtotal	1,590	1,094	68.8%	13.5	269.2	39.1	F
EB	Left Turn	310	228	73.7%	5.0	115.3	4.3	F
	Through	570	429	75.2%	6.3	122.3	2.6	F
	Right Turn	320	235	73.6%	5.1	117.4	3.9	F
	Subtotal	1,200	893	74.4%	9.5	119.2	2.1	F
WB	Left Turn	100	53	52.9%	5.4	240.9	13.8	F
	Through	440	244	55.5%	10.6	251.6	20.8	F
	Right Turn	380	208	54.8%	10.0	248.6	42.3	F
	Subtotal	920	505	54.9%	15.5	248.3	24.9	F
Total		6,030	3,553	58.9%	35.8	312.8	19.4	F

VISSIM Post-Processor
Average Results from 10 Runs
Volume and Delay by Movement

Caltrain Electrification
2040 Project Mitigated
AM Peak Hour

Intersection 67

Park Ave/Meadow Drive

Side-street Stop

Direction	Movement	Volume (vph)		Percent Served	GEH	Total Delay (sec/veh)		
		Demand	Served			Average	Std. Dev.	LOS
NB	Left Turn	10	5	48.0%	1.9	1090.7	634.5	F
	Through							
	Right Turn	50	22	43.4%	4.7	1491.7	310.1	F
	Subtotal	60	27	44.2%	5.1	1334.0	329.1	F
SB	Left Turn							
	Through							
	Right Turn	5	4	82.0%	0.4	5.6	1.4	A
	Subtotal	5	4	82.0%	0.4	5.6	1.4	A
EB	Left Turn							
	Through	640	490	76.5%	6.3	213.9	7.6	F
	Right Turn	10	7	74.0%	0.9	165.3	90.8	F
	Subtotal	650	497	76.5%	6.4	212.7	8.5	F
WB	Left Turn							
	Through	610	429	70.3%	8.0	1.1	0.4	A
	Right Turn	130	89	68.3%	3.9	2.0	0.8	A
	Subtotal	740	518	69.9%	8.9	1.3	0.4	A
Total		1,455	1,045	71.8%	11.6	127.9	15.6	F

VISSIM Post-Processor
Average Results from 10 Runs
Volume and Delay by Movement

Caltrain Electrification
2040 Project Mitigated
AM Peak Hour

Intersection 68

Alma/Charleston Road

Side-street Stop

Direction	Movement	Volume (vph)		Percent Served	GEH	Total Delay (sec/veh)		
		Demand	Served			Average	Std. Dev.	LOS
NB	Left Turn	25	23	93.6%	0.3	319.7	182.8	F
	Through	10	8	84.0%	0.5	282.4	246.4	F
	Right Turn	25	22	86.8%	0.7	397.5	191.5	F
	Subtotal	60	54	89.2%	0.9	343.5	185.9	F
SB	Left Turn	25	24	96.8%	0.2	89.5	34.8	F
	Through	10	9	88.0%	0.4	37.5	37.8	E
	Right Turn	25	24	97.6%	0.1	30.4	24.5	D
	Subtotal	60	57	95.7%	0.3	57.4	25.2	F
EB	Left Turn	25	18	73.6%	1.4	73.8	17.9	F
	Through	1,150	846	73.5%	9.6	79.5	8.0	F
	Right Turn	25	16	65.6%	1.9	63.5	22.6	F
	Subtotal	1,200	880	73.4%	9.9	79.1	8.0	F
WB	Left Turn	25	14	54.0%	2.6	8.6	10.7	A
	Through	1,100	557	50.6%	18.9	1.0	0.6	A
	Right Turn	25	14	56.0%	2.5	2.1	2.2	A
	Subtotal	1,150	585	50.8%	19.2	1.2	0.6	A
Total		2,470	1,576	63.8%	19.9	71.1	8.2	F

Intersection 63

Alma Street/Meadow Drive

Signal

Direction	Movement	Volume (vph)		Percent Served	GEH	Total Delay (sec/veh)		
		Demand	Served			Average	Std. Dev.	LOS
NB	Left Turn	80	50	62.9%	3.7	76.9	16.5	E
	Through	1,560	1,017	65.2%	15.1	31.1	4.9	C
	Right Turn	80	52	65.5%	3.4	25.9	8.7	C
	Subtotal	1,720	1,120	65.1%	15.9	33.0	5.3	C
SB	Left Turn	70	54	76.4%	2.1	508.0	50.8	F
	Through	1,690	1,260	74.6%	11.2	255.7	38.3	F
	Right Turn	320	238	74.3%	4.9	220.6	27.3	F
	Subtotal	2,080	1,551	74.6%	12.4	260.1	38.5	F
EB	Left Turn	220	150	68.4%	5.1	237.9	7.8	F
	Through	320	223	69.7%	5.9	233.4	5.3	F
	Right Turn	100	70	69.8%	3.3	225.6	12.8	F
	Subtotal	640	443	69.2%	8.5	233.3	2.7	F
WB	Left Turn	90	80	88.9%	1.1	246.7	30.9	F
	Through	300	281	93.7%	1.1	251.3	34.0	F
	Right Turn	80	72	90.4%	0.9	230.5	39.8	F
	Subtotal	470	434	92.2%	1.7	246.9	33.8	F
Total		4,910	3,547	72.2%	21.0	183.5	9.8	F

Intersection 68

Alma Street/Charleston Road

Signal

Direction	Movement	Volume (vph)		Percent Served	GEH	Total Delay (sec/veh)		
		Demand	Served			Average	Std. Dev.	LOS
NB	Left Turn	470	317	67.5%	7.7	270.9	27.9	F
	Through	1,510	1,003	66.4%	14.3	234.3	20.5	F
	Right Turn	80	57	71.3%	2.8	235.9	22.4	F
	Subtotal	2,060	1,377	66.9%	16.5	245.1	18.0	F
SB	Left Turn	290	218	75.3%	4.5	172.1	39.8	F
	Through	1,270	969	76.3%	9.0	123.7	19.0	F
	Right Turn	360	270	75.0%	5.1	101.9	15.4	F
	Subtotal	1,920	1,457	75.9%	11.3	126.7	20.7	F
EB	Left Turn	100	60	60.1%	4.5	193.7	6.9	F
	Through	690	411	59.6%	11.9	198.5	9.4	F
	Right Turn	610	360	58.9%	11.4	195.6	6.6	F
	Subtotal	1,400	831	59.3%	17.0	196.9	7.4	F
WB	Left Turn	330	160	48.5%	10.9	203.6	31.7	F
	Through	680	345	50.7%	14.8	208.0	20.7	F
	Right Turn	110	54	48.9%	6.2	195.8	25.9	F
	Subtotal	1,120	559	49.9%	19.4	205.9	22.4	F
Total		6,500	4,224	65.0%	31.1	189.6	16.5	F

VISSIM Post-Processor
Average Results from 10 Runs
Volume and Delay by Movement

Caltrain Electrification
2040 Project Mitigated
AM Peak Hour

Intersection 67

Park Ave/Meadow Drive

Side-street Stop

Direction	Movement	Volume (vph)		Percent Served	GEH	Total Delay (sec/veh)		
		Demand	Served			Average	Std. Dev.	LOS
NB	Left Turn	10	8	75.0%	0.8	587.5	481.4	F
	Through							
	Right Turn	30	25	82.0%	1.0	722.1	346.4	F
	Subtotal	40	32	80.3%	1.3	680.4	370.6	F
SB	Left Turn							
	Through							
	Right Turn	5	17	342.0%	3.6	6.2	3.1	A
	Subtotal	5	17	342.0%	3.6	6.2	3.1	A
EB	Left Turn							
	Through	610	418	68.6%	8.5	170.5	7.0	F
	Right Turn	30	20	68.0%	1.9	157.6	22.6	F
	Subtotal	640	439	68.5%	8.7	169.9	7.1	F
WB	Left Turn							
	Through	560	454	81.0%	4.7	1.4	0.6	A
	Right Turn	140	116	82.8%	2.1	2.3	1.0	A
	Subtotal	700	570	81.4%	5.2	1.6	0.6	A
Total		1,385	1,057	76.3%	9.4	91.6	9.7	F

VISSIM Post-Processor
Average Results from 10 Runs
Volume and Delay by Movement

Caltrain Electrification
2040 Project Mitigated
AM Peak Hour

Intersection 68

Alma/Charleston Road

Side-street Stop

Direction	Movement	Volume (vph)		Percent Served	GEH	Total Delay (sec/veh)		
		Demand	Served			Average	Std. Dev.	LOS
NB	Left Turn	25	17	68.8%	1.7	280.5	246.2	F
	Through	10	7	67.0%	1.1	137.9	277.2	F
	Right Turn	25	19	76.4%	1.3	317.9	240.3	F
	Subtotal	60	43	71.7%	2.4	266.6	230.6	F
SB	Left Turn	25	22	89.6%	0.5	58.1	25.0	F
	Through	10	11	106.0%	0.2	42.8	29.2	E
	Right Turn	25	24	97.6%	0.1	14.7	9.2	B
	Subtotal	60	57	95.7%	0.3	36.0	17.9	E
EB	Left Turn	25	13	52.4%	2.7	114.2	30.9	F
	Through	1,350	790	58.5%	17.1	150.7	3.7	F
	Right Turn	25	15	60.4%	2.2	123.3	69.9	F
	Subtotal	1,400	818	58.4%	17.5	149.1	3.6	F
WB	Left Turn	25	15	60.0%	2.2	8.0	8.1	A
	Through	1,460	902	61.8%	16.2	0.8	0.3	A
	Right Turn	25	17	66.4%	1.8	1.8	1.5	A
	Subtotal	1,510	934	61.8%	16.5	0.9	0.4	A
Total		3,030	1,852	61.1%	23.8	93.9	7.7	F

**ATTACHMENT I
TRAFFIC VOLUMES COUNT SHEETS**



Existing Conditions



INTERSECTION CAR/PED/BIKE TRAFFIC COUNT RESULTS SUMMARY

CLIENT: FEHR & PEERS
 PROJECT: CALTRAIN TRAFFIC COUNTS
 DATE: THURSDAY MAY 23, 2012
 PERIOD: 7:00 AM TO 9:00 AM
 INTERSECTION: N/S 4TH STREET
 E/W KING STREET
 CITY: SAN FRANCISCO

VEHICLE COUNTS													
15 MIN COUNTS	1	2	3	4	5	6	7	8	9	10	11	12	
PERIOD	SBRT	SBTH	SBLT	WBRT	WBTH	WBLT	NBRT	NBTH	NBLT	EBRT	EBTH	EBLT	TOTAL
700-715	40	51	15	6	138	4	0	1	0	3	284	11	553
715-730	55	82	15	2	154	12	6	12	1	2	321	18	680
730-745	56	79	18	6	159	8	8	10	2	0	334	15	695
745-800	55	88	14	10	176	6	10	12	3	1	387	21	783
800-815	50	75	15	6	160	3	6	13	2	0	341	22	693
815-830	52	88	14	10	169	3	8	12	1	0	350	15	722
830-845	56	92	15	8	195	13	14	11	2	0	388	21	815
845-900	60	104	19	3	178	13	5	13	1	0	392	22	810
HOUR TOTALS	1	2	3	4	5	6	7	8	9	10	11	12	
PERIOD	SBRT	SBTH	SBLT	WBRT	WBTH	WBLT	NBRT	NBTH	NBLT	EBRT	EBTH	EBLT	TOTAL
700-800	206	300	62	24	627	30	24	35	6	6	1326	65	2711
715-815	216	324	62	24	649	29	30	47	8	3	1383	76	2851
730-830	213	330	61	32	664	20	32	47	8	1	1412	73	2893
745-845	213	343	58	34	700	25	38	48	8	1	1466	79	3013
800-900	218	359	63	27	702	32	33	49	6	0	1471	80	3040

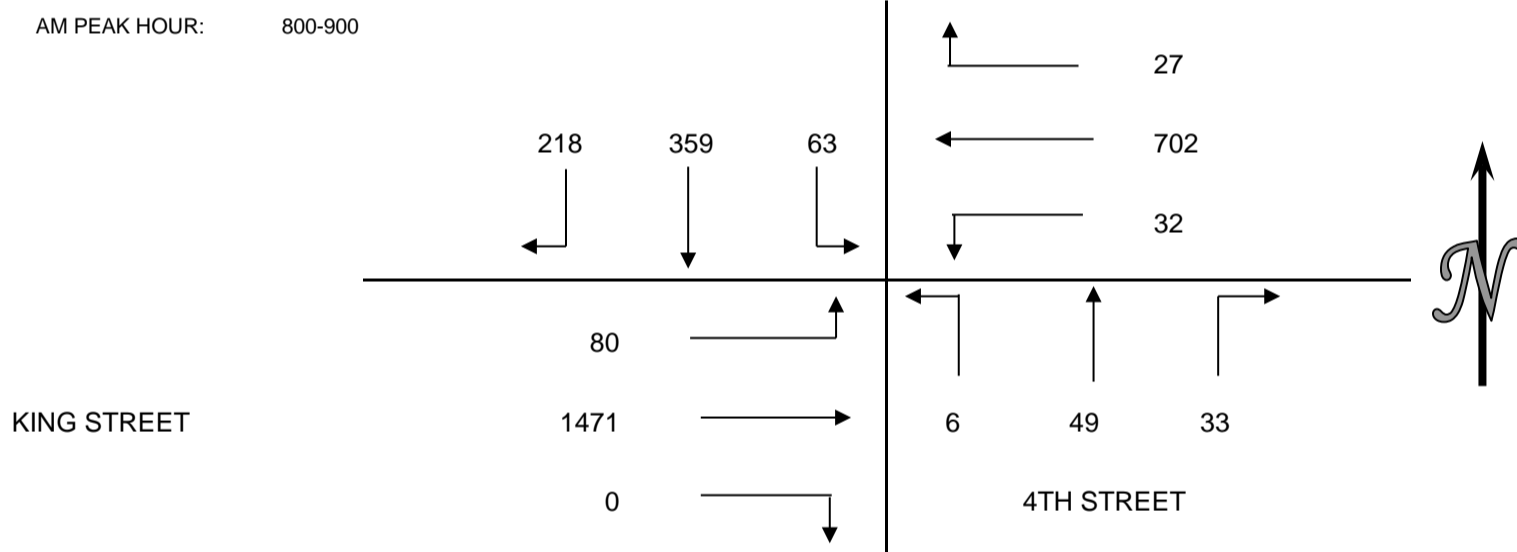

PEDESTRIAN COUNTS					
15 MIN COUNTS	NORTH LEG	EAST LEG	SOUTH LEG	WEST LEG	TOTAL
PERIOD					
700-715	60	50	30	28	168
715-730	78	60	15	30	183
730-745	88	42	19	28	177
745-800	112	70	20	32	234
800-815	147	62	30	30	269
815-830	122	59	33	25	239
830-845	102	49	29	26	206
845-900	93	37	31	22	183
HOUR TOTALS	NORTH LEG	EAST LEG	SOUTH LEG	WEST LEG	TOTAL
PERIOD					
700-800	338	222	84	118	762
715-815	425	234	84	120	863
730-830	469	233	102	115	919
745-845	483	240	112	113	948
800-900	464	207	123	103	897

BICYCLE COUNTS					
15 MIN COUNTS	NORTH LEG	EAST LEG	SOUTH LEG	WEST LEG	TOTAL
PERIOD					
700-715	4	3	0	0	7
715-730	9	2	0	0	11
730-745	1	2	1	0	4
745-800	8	2	0	5	15
800-815	4	1	0	9	14
815-830	2	3	0	5	10
830-845	4	5	2	7	18
845-900	6	3	0	1	10
HOUR TOTALS	NORTH LEG	EAST LEG	SOUTH LEG	WEST LEG	TOTAL
PERIOD					
700-800	22	9	1	5	37
715-815	22	7	1	14	44
730-830	15	8	1	19	43
745-845	18	11	2	26	57
800-900	16	12	2	22	52

800-815	73.5	31	15	15	134.5
815-830	61	29.5	16.5	12.5	119.5
830-845	51	24.5	14.5	13	103
845-900	46.5	18.5	15.5	11	91.5
	232	103.5	61.5	51.5	448.5

wbr 12 nbt 12 ebt 2 sbl 6
 4 sbt 16
 WBL

INTERSECTION CAR/PED/BIKE TRAFFIC COUNT RESULTS SUMMARY

CLIENT: FEHR & PEERS
 PROJECT: CALTRAIN TRAFFIC COUNTS
 DATE: THURSDAY MAY 23, 2012
 PERIOD: 4:00 PM TO 6:00 PM
 INTERSECTION: N/S 4TH STREET
 E/W KING STREET
 CITY: SAN FRANCISCO

VEHICLE COUNTS													
15 MIN COUNTS	1	2	3	4	5	6	7	8	9	10	11	12	TOTAL
PERIOD	SBRT	SBTH	SBLT	WBRT	WBTH	WBLT	NBRT	NBTH	NBLT	EBRT	EBTH	EBLT	
400-415	71	58	12	4	230	11	11	14	8	2	301	20	742
415-430	75	70	18	3	228	6	15	15	2	0	265	16	713
430-445	93	60	7	4	209	10	13	17	2	0	285	25	725
445-500	111	69	14	3	210	2	7	16	0	4	325	23	784
500-515	121	52	14	6	218	10	12	26	2	0	346	28	835
515-530	121	71	15	5	248	8	12	14	1	2	389	34	920
530-545	104	63	16	2	234	4	12	10	4	6	328	36	819
545-600	110	60	9	4	251	7	10	16	4	2	303	39	815
HOUR TOTALS	1	2	3	4	5	6	7	8	9	10	11	12	TOTAL
PERIOD	SBRT	SBTH	SBLT	WBRT	WBTH	WBLT	NBRT	NBTH	NBLT	EBRT	EBTH	EBLT	
400-500	350	257	51	14	877	29	46	62	12	6	1176	84	2964
415-515	400	251	53	16	865	28	47	74	6	4	1221	92	3057
430-530	446	252	50	18	885	30	44	73	5	6	1345	110	3264
445-545	457	255	59	16	910	24	43	66	7	12	1388	121	3358
500-600	456	246	54	17	951	29	46	66	11	10	1366	137	3389
AM PEAK HOUR: 500-600	456	246	54	17	951	29	46	66	11	10	1366	137	3389

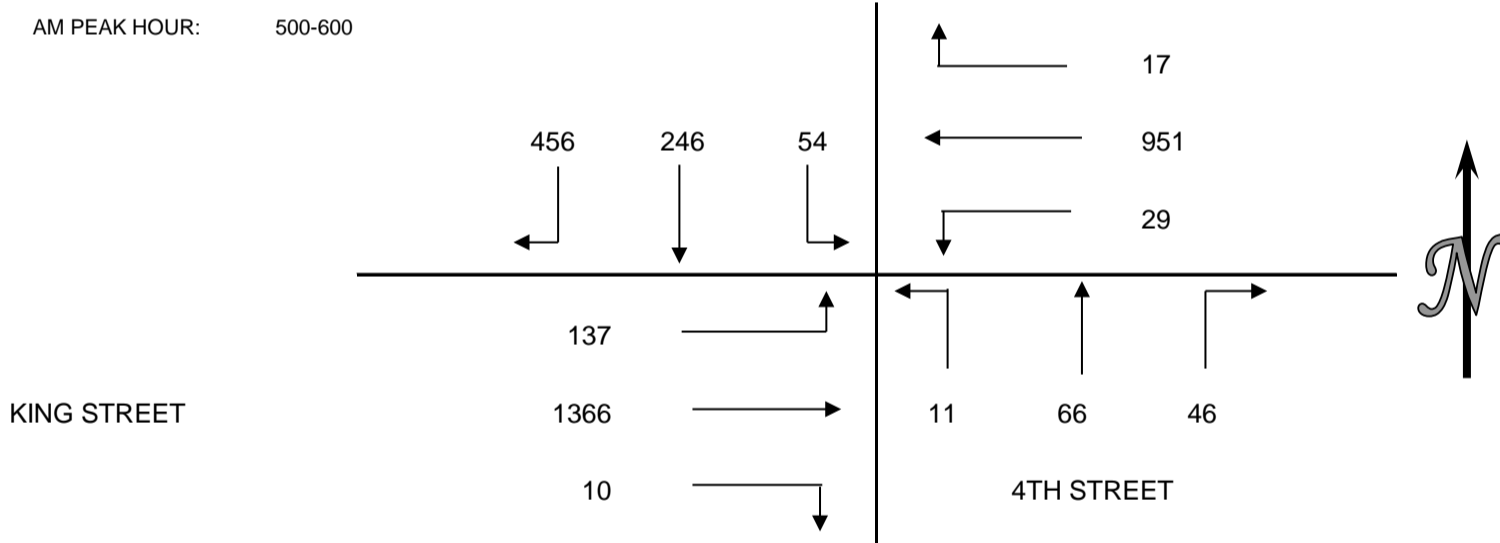

PEDESTRIAN COUNTS					
15 MIN COUNTS	NORTH LEG	EAST LEG	SOUTH LEG	WEST LEG	TOTAL
PERIOD					
400-415	77	20	30	40	167
415-430	54	18	38	31	141
430-445	63	15	30	26	134
445-500	87	29	33	29	178
500-515	119	58	39	40	256
515-530	148	50	46	39	283
530-545	132	45	39	41	257
545-600	153	41	46	32	272
HOUR TOTALS	NORTH LEG	EAST LEG	SOUTH LEG	WEST LEG	TOTAL
PERIOD					
400-500	281	82	131	126	620
415-515	323	120	140	126	709
430-530	417	152	148	134	851
445-545	486	182	157	149	974
500-600	552	194	170	152	1068

276 97 85 76 534

BICYCLE COUNTS					
15 MIN COUNTS	NORTH LEG	EAST LEG	SOUTH LEG	WEST LEG	TOTAL
PERIOD					
400-415	1	13	6	1	21
415-430	1	7	0	0	8
430-445	9	6	0	0	15
445-500	1	3	0	0	4
500-515	10	13	5	1	29
515-530	19	9	7	0	35
530-545	14	6	9	2	31
545-600	12	4	6	4	26
HOUR TOTALS	NORTH LEG	EAST LEG	SOUTH LEG	WEST LEG	TOTAL
PERIOD					
400-500	12	29	6	1	48
415-515	21	29	5	1	56
430-530	39	31	12	1	83
445-545	44	31	21	3	99
500-600	55	32	27	7	121

37 26 27 7
 WBT NBT EBT SBT
 18 6
 WBR NBR

INTERSECTION CAR/PED/BIKE TRAFFIC COUNT RESULTS SUMMARY

CLIENT: FEHR & PEERS
 PROJECT: CALTRAIN TRAFFIC COUNTS
 DATE: THURSDAY MAY 23, 2012
 PERIOD: 7:00 AM TO 9:00 AM
 INTERSECTION: N/S 4TH STREET
 E/W TOWNSEND STREET
 CITY: SAN FRANCISCO

VEHICLE COUNTS													
15 MIN COUNTS	1	2	3	4	5	6	7	8	9	10	11	12	
PERIOD	SBRT	SBTH	SBLT	WBRT	WBTH	WBLT	NBRT	NBTH	NBLT	EBRT	EBTH	EBLT	TOTAL
700-715	8	78	13	43	22	22	35	0	6	19	72	0	318
715-730	16	84	29	35	19	19	31	0	3	29	75	0	340
730-745	16	89	17	35	29	29	29	0	4	33	65	0	346
745-800	16	97	29	38	22	22	37	0	6	35	75	0	377
800-815	17	83	30	50	29	29	32	0	3	33	95	0	401
815-830	13	104	21	51	33	33	35	0	4	27	76	0	397
830-845	21	80	39	53	49	49	36	0	8	32	84	0	451
845-900	23	94	23	59	41	41	37	0	7	34	100	0	459
HOUR TOTALS	1	2	3	4	5	6	7	8	9	10	11	12	
PERIOD	SBRT	SBTH	SBLT	WBRT	WBTH	WBLT	NBRT	NBTH	NBLT	EBRT	EBTH	EBLT	TOTAL
700-800	56	348	88	151	92	92	132	0	19	116	287	0	1381
715-815	65	353	105	158	99	99	129	0	16	130	310	0	1464
730-830	62	373	97	174	113	113	133	0	17	128	311	0	1521
745-845	67	364	119	192	133	133	140	0	21	127	330	0	1626
800-900	74	361	113	213	152	152	140	0	22	126	355	0	1708

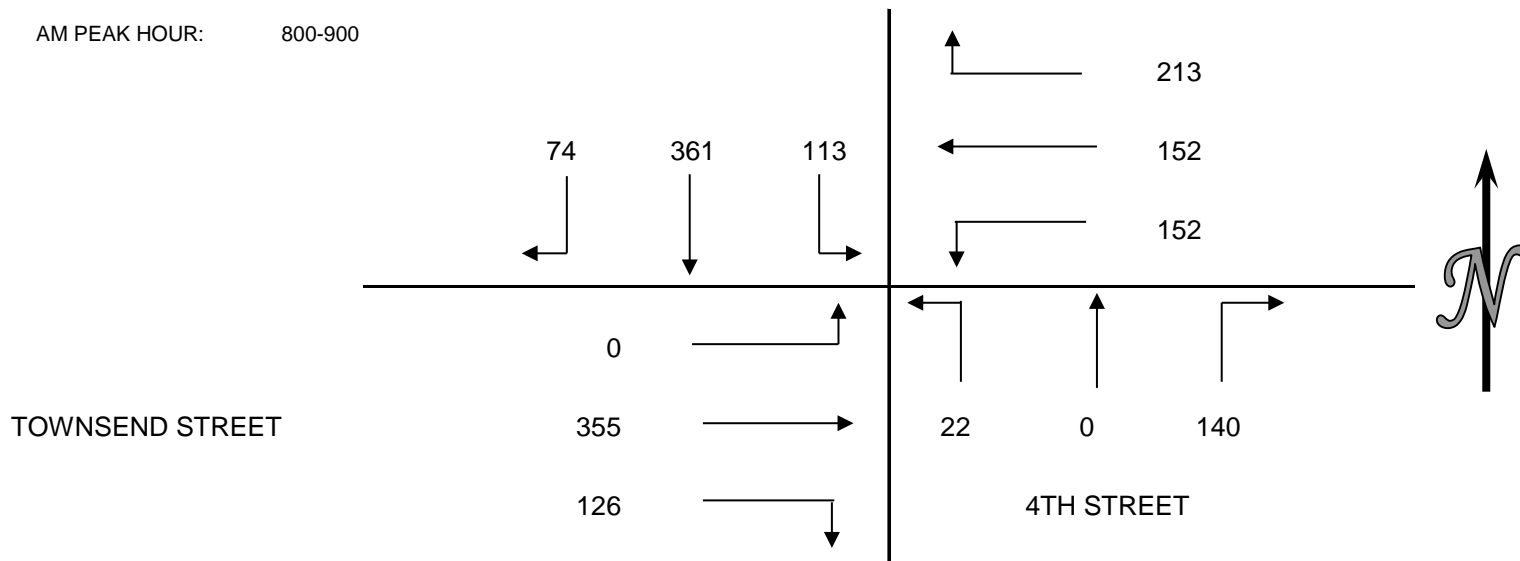

PEDESTRIAN COUNTS					
15 MIN COUNTS	NORTH LEG	EAST LEG	SOUTH LEG	WEST LEG	TOTAL
PERIOD	LEG	LEG	LEG	LEG	
700-715	79	39	86	172	376
715-730	111	48	67	188	414
730-745	89	38	38	221	386
745-800	108	91	149	258	606
800-815	108	119	257	288	772
815-830	104	82	141	265	592
830-845	88	97	138	228	551
845-900	119	55	129	237	540
HOUR TOTALS	NORTH LEG	EAST LEG	SOUTH LEG	WEST LEG	TOTAL
PERIOD	LEG	LEG	LEG	LEG	
700-800	387	216	340	839	1782
715-815	416	296	511	955	2178
730-830	409	330	585	1032	2356
745-845	408	389	685	1039	2521
800-900	419	353	665	1018	2455

BICYCLE COUNTS					
15 MIN COUNTS	NORTH LEG	EAST LEG	SOUTH LEG	WEST LEG	TOTAL
PERIOD	LEG	LEG	LEG	LEG	
700-715	18	8	5	16	47
715-730	31	2	14	13	60
730-745	26	1	18	23	68
745-800	33	3	19	12	67
800-815	22	11	23	13	69
815-830	23	6	23	16	68
830-845	24	0	43	10	77
845-900	25	2	68	14	109
HOUR TOTALS	NORTH LEG	EAST LEG	SOUTH LEG	WEST LEG	TOTAL
PERIOD	LEG	LEG	LEG	LEG	
700-800	108	14	56	64	242
715-815	112	17	74	61	264
730-830	104	21	83	64	272
745-845	102	20	108	51	281
800-900	94	19	157	53	323

209.5 176.5 332.5 509

94 19 125 35
 WBT NBR EBT SBL
 12 18
 EBR SBT
 20
 SWLK

INTERSECTION CAR/PED/BIKE TRAFFIC COUNT RESULTS SUMMARY

CLIENT: FEHR & PEERS
 PROJECT: CALTRAIN TRAFFIC COUNTS
 DATE: THURSDAY MAY 23, 2012
 PERIOD: 4:00 PM TO 6:00 PM
 INTERSECTION: N/S 4TH STREET
 E/W TOWNSEND STREET
 CITY: SAN FRANCISCO

VEHICLE COUNTS													
15 MIN COUNTS	1	2	3	4	5	6	7	8	9	10	11	12	TOTAL
PERIOD	SBRT	SBTH	SBLT	WBRT	WBTH	WBLT	NBRT	NBTH	NBLT	EBRT	EBTH	EBLT	
400-415	16	82	16	0	59	36	32	0	3	25	69	0	338
415-430	12	81	19	0	66	35	42	0	5	34	76	0	370
430-445	17	88	33	0	57	44	37	0	5	35	87	0	403
445-500	15	103	22	0	88	52	48	0	5	26	80	0	439
500-515	19	98	28	0	71	54	57	0	2	31	73	0	433
515-530	25	122	30	0	83	61	52	0	3	38	78	0	492
530-545	18	130	32	0	73	55	47	0	5	32	68	0	460
545-600	21	104	23	0	81	56	48	0	6	25	73	0	437
HOUR TOTALS	1	2	3	4	5	6	7	8	9	10	11	12	TOTAL
PERIOD	SBRT	SBTH	SBLT	WBRT	WBTH	WBLT	NBRT	NBTH	NBLT	EBRT	EBTH	EBLT	
400-500	60	354	90	0	270	167	159	0	18	120	312	0	1550
415-515	63	370	102	0	282	185	184	0	17	126	316	0	1645
430-530	76	411	113	0	299	211	194	0	15	130	318	0	1767
445-545	77	453	112	0	315	222	204	0	15	127	299	0	1824
500-600	83	454	113	0	308	226	204	0	16	126	292	0	1822
	83	454	113	0	308	226	204	0	16	126	292	0	1822

AM PEAK HOUR: 445-545

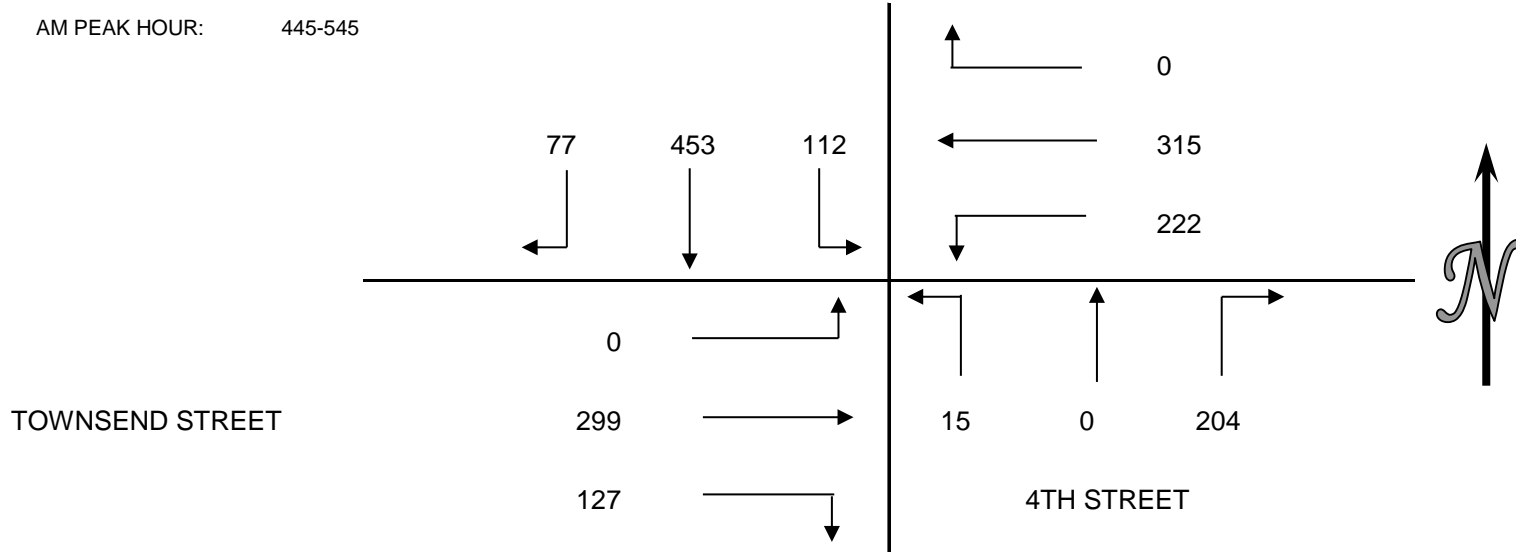

PEDESTRIAN COUNTS					
15 MIN COUNTS	NORTH LEG	EAST LEG	SOUTH LEG	WEST LEG	TOTAL
PERIOD					
400-415	79	89	89	172	429
415-430	111	68	89	188	456
430-445	89	78	81	221	469
445-500	108	92	111	258	569
500-515	107	123	198	288	716
515-530	104	106	179	265	654
530-545	88	134	124	228	574
545-600	119	110	188	237	654
HOUR TOTALS	NORTH LEG	EAST LEG	SOUTH LEG	WEST LEG	TOTAL
PERIOD					
400-500	387	327	370	839	1923
415-515	415	361	479	955	2210
430-530	408	399	569	1032	2408
445-545	407	455	612	1039	2513
500-600	418	473	689	1018	2598

209 236.5 344.5 509 1299

BICYCLE COUNTS					
15 MIN COUNTS	NORTH LEG	EAST LEG	SOUTH LEG	WEST LEG	TOTAL
PERIOD					
400-415	18	4	7	16	45
415-430	31	4	4	13	52
430-445	26	2	11	23	62
445-500	33	6	9	12	60
500-515	22	12	30	13	77
515-530	23	14	18	16	71
530-545	24	7	13	10	54
545-600	25	8	24	14	71
HOUR TOTALS	NORTH LEG	EAST LEG	SOUTH LEG	WEST LEG	TOTAL
PERIOD					
400-500	108	16	31	64	219
415-515	112	24	54	61	251
430-530	104	34	68	64	270
445-545	102	39	70	51	262
500-600	94	41	85	53	273

92 27 80 43
 WBT NBL EBT SBT
 2 14 5 7
 WBL NBR EBR SBR
 3
 SBL

All Traffic Data

(916) 771-8700

City of San Francisco

File Name : 12-7153-026 7th-Mission Bay

Site Code : 00000000

Start Date : 4/18/2012

Page No : 1

Groups Printed- Unshifted

Start Time	7th Street Southbound				Mission Bay Drive Westbound				7th Street Northbound				Driveway Eastbound				Int. Total
	Left	Thru	Right	App. Total	Left	Thru	Right	App. Total	Left	Thru	Right	App. Total	Left	Thru	Right	App. Total	
07:00	2	49	0	51	4	0	10	14	0	66	5	71	0	0	0	0	136
07:15	2	66	1	69	3	0	13	16	1	82	3	86	0	0	0	0	171
07:30	4	57	0	61	8	0	22	30	1	137	3	141	0	0	0	0	232
07:45	4	49	1	54	7	0	11	18	2	139	3	144	0	0	0	0	216
Total	12	221	2	235	22	0	56	78	4	424	14	442	0	0	0	0	755
08:00	12	49	0	61	5	0	20	25	1	174	8	183	0	0	0	0	269
08:15	9	70	0	79	5	0	16	21	0	164	5	169	0	0	0	0	269
08:30	5	73	0	78	6	0	10	16	0	176	12	188	0	0	0	0	282
08:45	11	57	1	69	7	0	16	23	0	179	18	197	0	0	0	0	289
Total	37	249	1	287	23	0	62	85	1	693	43	737	0	0	0	0	1109
16:00	12	56	0	68	2	0	10	12	0	166	10	176	0	0	0	0	256
16:15	15	50	0	65	8	0	14	22	0	152	9	161	0	0	0	0	248
16:30	9	56	0	65	3	0	15	18	0	207	5	212	0	0	0	0	295
16:45	14	47	1	62	2	0	17	19	0	234	9	243	0	0	0	0	324
Total	50	209	1	260	15	0	56	71	0	759	33	792	0	0	0	0	1123
17:00	22	59	0	81	5	0	19	24	0	238	15	253	0	0	0	0	358
17:15	26	48	0	74	9	0	11	20	0	187	10	197	0	0	0	0	291
17:30	18	70	1	89	8	0	12	20	0	216	18	234	0	0	0	0	343
17:45	14	56	0	70	7	0	19	26	0	212	9	221	0	0	0	0	317
Total	80	233	1	314	29	0	61	90	0	853	52	905	0	0	0	0	1309
Grand Total	179	912	5	1096	89	0	235	324	5	2729	142	2876	0	0	0	0	4296
Apprch %	16.3	83.2	0.5		27.5	0	72.5		0.2	94.9	4.9		0	0	0		
Total %	4.2	21.2	0.1	25.5	2.1	0	5.5	7.5	0.1	63.5	3.3	66.9	0	0	0	0	

Start Time	7th Street Southbound				Mission Bay Drive Westbound				7th Street Northbound				Driveway Eastbound				Int. Total
	Left	Thru	Right	App. Total	Left	Thru	Right	App. Total	Left	Thru	Right	App. Total	Left	Thru	Right	App. Total	
Peak Hour Analysis From 07:00 to 08:45 - Peak 1 of 1																	
Peak Hour for Entire Intersection Begins at 08:00																	
08:00	12	49	0	61	5	0	20	25	1	174	8	183	0	0	0	0	269
08:15	9	70	0	79	5	0	16	21	0	164	5	169	0	0	0	0	269
08:30	5	73	0	78	6	0	10	16	0	176	12	188	0	0	0	0	282
08:45	11	57	1	69	7	0	16	23	0	179	18	197	0	0	0	0	289
Total Volume	37	249	1	287	23	0	62	85	1	693	43	737	0	0	0	0	1109
% App. Total	12.9	86.8	0.3		27.1	0	72.9		0.1	94	5.8		0	0	0		

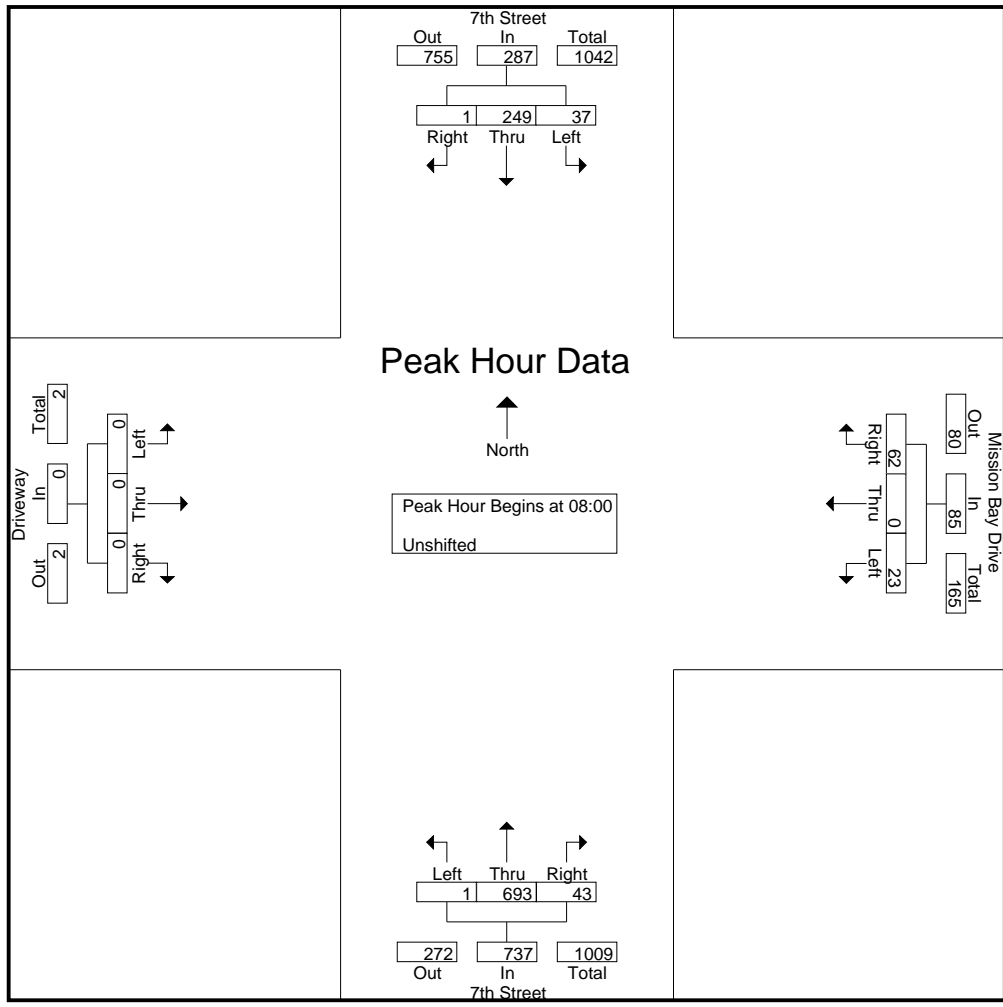

Peak Hour Analysis From 16:00 to 17:45 - Peak 1 of 1
 Peak Hour for Entire Intersection Begins at 16:45

16:45	14	47	1	62	2	0	17	19	0	234	9	243	0	0	0	0	324
17:00	22	59	0	81	5	0	19	24	0	238	15	253	0	0	0	0	358
17:15	26	48	0	74	9	0	11	20	0	187	10	197	0	0	0	0	291
17:30	18	70	1	89	8	0	12	20	0	216	18	234	0	0	0	0	343
Total Volume	80	224	2	306	24	0	59	83	0	875	52	927	0	0	0	0	1316
% App. Total	26.1	73.2	0.7		28.9	0	71.1		0	94.4	5.6		0	0	0		
PHF	.769	.800	.500	.860	.667	.000	.776	.865	.000	.919	.722	.916	.000	.000	.000	.000	.919

All Traffic Data

(916) 771-8700

City of San Francisco

File Name : 12-7153-026 7th-Mission Bay

Site Code : 00000000

Start Date : 4/18/2012

Page No : 3

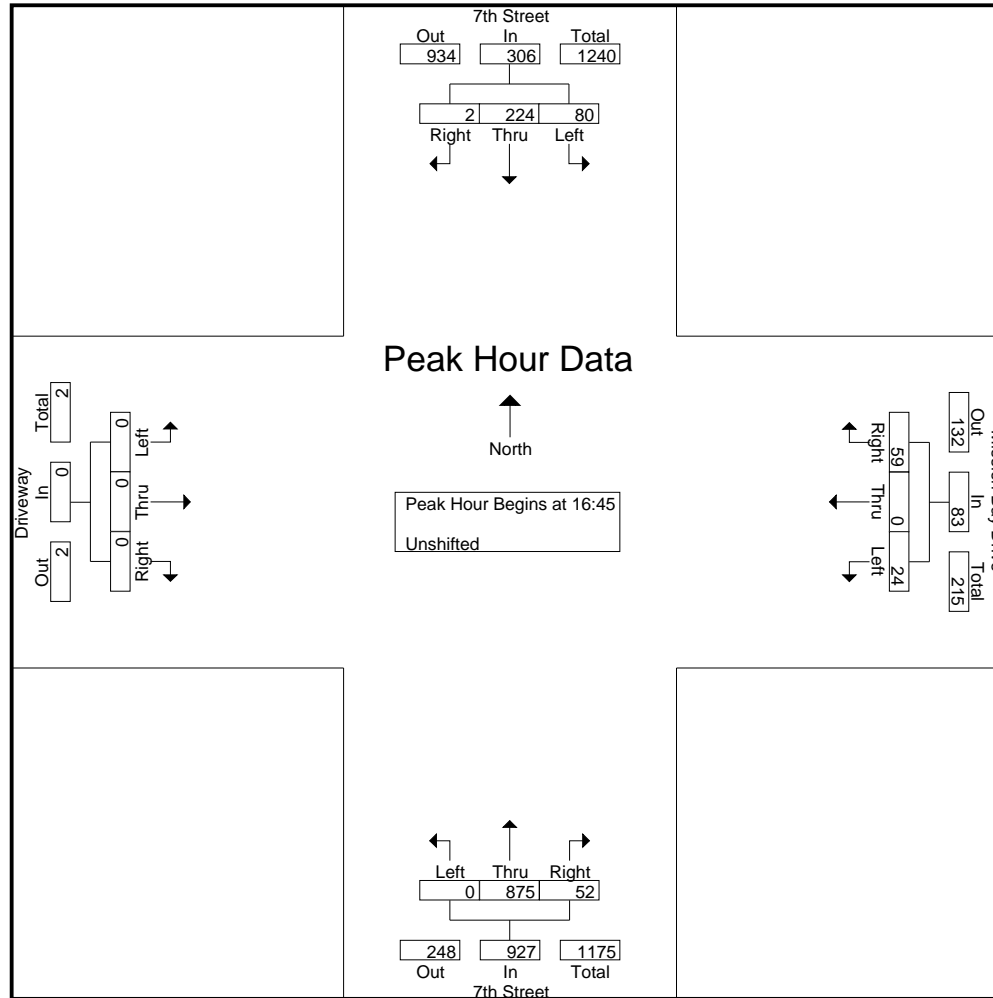

Intersection ID 13-7485-027
 Jurisdiction San Francisco San Francisco CA USA
 Date 9/12/2013
 Coord1 Coord2
 Street N Seventh Street
 Street N2
 Street E 16th Street
 Street E2
 Street S Seventh Street
 Street S2
 Street W 16th Street
 Street W2

DESCRIPTION	TIME BEGIN	TIME END	NBL	NBLT	NBT	NBLTR	NBTR	NBR	NBLR
Control	0:00	0:00							
Lanes	0:00	0:00							
Signal Phasing	0:00	0:00							
MODE	TIME BEGIN	TIME END	NBL	NBL2	NBT	NBT2	NBR	NBR2	NBU
Vehicle	7:05	7:10							
Vehicle	7:10	7:15	11		64		14		0
Vehicle	7:15	7:20							
Vehicle	7:20	7:25							
Vehicle	7:25	7:30	16		87		21		0
Vehicle	7:30	7:35							
Vehicle	7:35	7:40							
Vehicle	7:40	7:45	12		102		25		0
Vehicle	7:45	7:50							
Vehicle	7:50	7:55							
Vehicle	7:55	8:00	12		92		22		0
Vehicle	8:00	8:05							
Vehicle	8:05	8:10							
Vehicle	8:10	8:15	18		104		23		0
Vehicle	8:15	8:20							
Vehicle	8:20	8:25							
Vehicle	8:25	8:30	7		95		24		0
Vehicle	8:30	8:35							
Vehicle	8:35	8:40							
Vehicle	8:40	8:45	17		98		33		0
Vehicle	8:45	8:50							
Vehicle	8:50	8:55							
Vehicle	8:55	9:00	7		86		26		0
Vehicle	9:00	9:05							
Bicycle	7:05	7:10							
Bicycle	7:10	7:15	0		0		1		
Bicycle	7:15	7:20							
Bicycle	7:20	7:25							
Bicycle	7:25	7:30	0		1		1		
Bicycle	7:30	7:35							
Bicycle	7:35	7:40							
Bicycle	7:40	7:45	2		0		5		
Bicycle	7:45	7:50							
Bicycle	7:50	7:55							
Bicycle	7:55	8:00	0		3		6		

Bicycle	8:00	8:05				
Bicycle	8:05	8:10				
Bicycle	8:10	8:15	0	5	7	
Bicycle	8:15	8:20				
Bicycle	8:20	8:25				
Bicycle	8:25	8:30	0	7	7	
Bicycle	8:30	8:35				
Bicycle	8:35	8:40				
Bicycle	8:40	8:45	0	12	8	
Bicycle	8:45	8:50				
Bicycle	8:50	8:55				
Bicycle	8:55	9:00	0	8	18	
Bicycle	9:00	9:05				
Pedestrian	7:00	7:05				
Pedestrian	7:05	7:10				
Pedestrian	7:10	7:15	8	0	1	0
Pedestrian	7:15	7:20				
Pedestrian	7:20	7:25				
Pedestrian	7:25	7:30	10	0	3	1
Pedestrian	7:30	7:35				
Pedestrian	7:35	7:40				
Pedestrian	7:40	7:45	24	0	3	4
Pedestrian	7:45	7:50				
Pedestrian	7:50	7:55				
Pedestrian	7:55	8:00	9	0	3	6
Pedestrian	8:00	8:05				
Pedestrian	8:05	8:10				
Pedestrian	8:10	8:15	15	0	7	7
Pedestrian	8:15	8:20				
Pedestrian	8:20	8:25				
Pedestrian	8:25	8:30	23	0	4	3
Pedestrian	8:30	8:35				
Pedestrian	8:35	8:40				
Pedestrian	8:40	8:45	14	0	8	2
Pedestrian	8:45	8:50				
Pedestrian	8:50	8:55				
Pedestrian	8:55	9:00	11	0	7	1
Pedestrian	9:00	9:05				

NBU NB2L NB2LT NB2T NB2LTR NB2TR NB2R NB2LR NB2U EBL EBLT EBT EBLTR EBTR

NBU2	NB2L	NB2L2	NB2T	NB2T2	NB2R	NB2R2	NB2U	NB2U2	EBL	EBL2	EBT	EBT2	EBR
									4	44			24
									5	55			23
									8	75			23
									8	70			16
									10	94			25
									5	93			14
									5	90			15
									15	97			26
									1	5			1
									0	3			1
									1	3			1
									1	6			0

0	5	2
1	7	1
0	7	0
2	21	2

EBR EBLR EBU EB2L EB2LT EB2T EB2LTR EB2TR EB2R EB2LR EB2U SBL SBLT SBT

EBR2 EBU EBU2 EB2L EB2L2 EB2T EB2T2 EB2R EB2R2 EB2U EB2U2 SBL SBL2 SBT

0 24 15

0 13 31

0 21 18

0 22 20

0 28 23

0 27 17

0 29 29

0 35 28

2 1

0 0

0 1

2 1

1 1

1 5

4 1

1 4

0

0

0

0

0

0

0

0

WBLT WBT WBLTR WBTR WBR WBLR WBU WB2L WB2LT WB2T WB2LTR WB2TR WB2R

WBL2 WBT WBT2 WBR WBR2 WBU WBU2 WB2L WB2L2 WB2T WB2T2 WB2R WB2R2

37 15 0

40 30 0

42 37 0

35 23 0

46 34 0

53 44 0

55 43 0

42 35 0

0 0

2 1

1 0

1 0

1	1
1	0
0	0
4	0

LOCATION: 7th St/Mississippi St -- 16th St
CITY/STATE: San Francisco, CA

QC JOB #: 10972615
DATE: Tue, Jun 11 2013

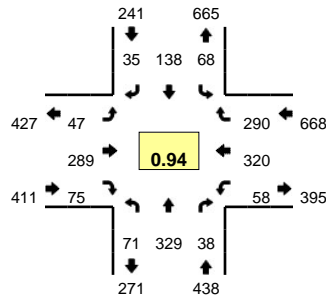

Peak-Hour: 5:00 PM -- 6:00 PM
Peak 15-Min: 5:00 PM -- 5:15 PM

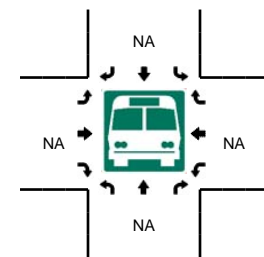
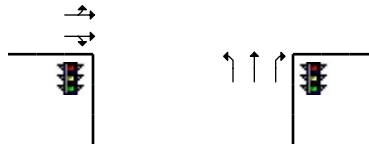
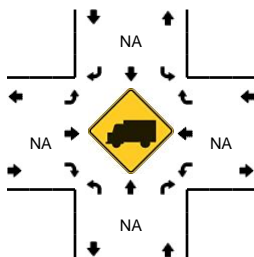
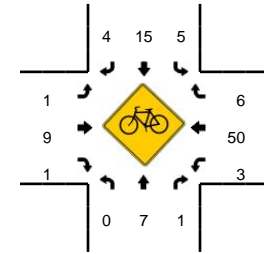
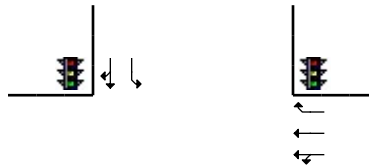
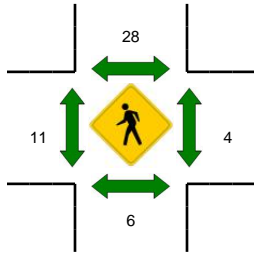
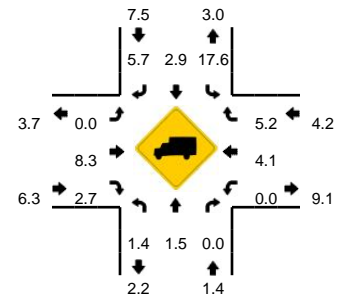

15-Min Count Period Beginning At	7th St/Mississippi St (Northbound)				7th St/Mississippi St (Southbound)				16th St (Eastbound)				16th St (Westbound)				Total	Hourly Totals
	Left	Thru	Right	U	Left	Thru	Right	U	Left	Thru	Right	U	Left	Thru	Right	U		
4:00 PM	19	85	4	0	14	28	6	0	5	53	18	0	10	61	61	0	364	
4:15 PM	21	73	6	0	23	34	11	0	9	63	29	0	14	61	44	0	388	
4:30 PM	20	110	11	0	17	32	3	0	6	64	20	0	13	58	56	0	410	
4:45 PM	10	86	11	0	13	21	8	0	7	73	22	0	17	74	40	0	382	1544
5:00 PM	15	92	12	0	15	33	5	0	11	74	18	0	16	77	99	0	467	1647
5:15 PM	16	73	5	0	26	35	8	0	16	71	14	0	15	80	61	0	420	1679
5:30 PM	21	82	12	0	12	36	9	0	12	82	19	1	12	88	75	0	461	1730
5:45 PM	19	82	9	0	15	34	13	0	7	62	24	0	15	75	55	0	410	1758
Peak 15-Min Flowrates	Northbound				Southbound				Eastbound				Westbound				Total	
All Vehicles	60	368	48	0	60	132	20	0	44	296	72	0	64	308	396	0	1868	
Heavy Trucks	4	0	0	0	8	0	4	0	0	12	4	0	0	8	20	0	60	
Pedestrians	0	0	0	0	0	0	0	0	0	0	0	0	0	0	0	0	0	
Bicycles	0	0	0	0	3	1	0	0	0	1	0	0	0	11	2	0	18	
Railroad																		
Stopped Buses																		

Comments:

Traffic Data Service

Campbell, CA
 (408) 377-2988
 tdsbay@cs.com

File Name : 4AM FINAL
 Site Code : 00000004
 Start Date : 6/6/2013
 Page No : 1

Groups Printed- Vehicles

Start Time	OWENS ST Southbound					16T ST Westbound					Northbound					16T ST Eastbound					Int. Total
	Right	Thru	Left	Peds	App. Total	Right	Thru	Left	Peds	App. Total	Right	Thru	Left	Peds	App. Total	Right	Thru	Left	Peds	App. Total	
07:00 AM	14	0	10	3	27	12	30	1	0	43	0	0	0	0	0	0	41	17	0	58	128
07:15 AM	14	0	9	6	29	13	50	0	0	63	0	0	0	0	0	0	80	45	1	126	218
07:30 AM	19	0	7	7	33	19	87	0	1	107	0	0	0	0	0	0	82	39	0	121	261
07:45 AM	9	0	14	3	26	18	65	0	0	83	0	0	0	0	0	0	69	34	1	104	213
Total	56	0	40	19	115	62	232	1	1	296	0	0	0	0	0	0	272	135	2	409	820
08:00 AM	29	0	9	2	40	24	68	1	0	93	0	0	0	0	0	0	88	61	0	149	282
08:15 AM	28	0	18	3	49	26	72	0	0	98	0	0	0	0	0	0	78	57	0	135	282
08:30 AM	22	0	11	3	36	31	81	1	0	113	0	0	0	0	0	0	90	62	2	154	303
08:45 AM	26	0	13	6	45	38	66	0	0	104	0	0	0	0	0	0	83	55	0	138	287
Total	105	0	51	14	170	119	287	2	0	408	0	0	0	0	0	0	339	235	2	576	1154
Grand Total	161	0	91	33	285	181	519	3	1	704	0	0	0	0	0	0	611	370	4	985	1974
Apprch %	56.5	0	31.9	11.6		25.7	73.7	0.4	0.1		0	0	0	0	0	0	62	37.6	0.4		
Total %	8.2	0	4.6	1.7	14.4	9.2	26.3	0.2	0.1	35.7	0	0	0	0	0	0	31	18.7	0.2	49.9	

Start Time	OWENS ST Southbound				16T ST Westbound				Northbound				16T ST Eastbound				Int. Total
	Right	Thru	Left	App. Total	Right	Thru	Left	App. Total	Right	Thru	Left	App. Total	Right	Thru	Left	App. Total	
Peak Hour Analysis From 07:00 AM to 08:45 AM - Peak 1 of 1																	
Peak Hour for Entire Intersection Begins at 08:00 AM																	
08:00 AM	29	0	9	38	24	68	1	93	0	0	0	0	0	88	61	149	280
08:15 AM	28	0	18	46	26	72	0	98	0	0	0	0	0	78	57	135	279
08:30 AM	22	0	11	33	31	81	1	113	0	0	0	0	0	90	62	152	298
08:45 AM	26	0	13	39	38	66	0	104	0	0	0	0	0	83	55	138	281
Total Volume	105	0	51	156	119	287	2	408	0	0	0	0	0	339	235	574	1138
% App. Total	67.3	0	32.7		29.2	70.3	0.5		0	0	0	0	0	59.1	40.9		
PHF	.905	.000	.708	.848	.783	.886	.500	.903	.000	.000	.000	.000	.000	.942	.948	.944	.955

Traffic Data Service

Campbell, CA
 (408) 377-2988
 tdsbay@cs.com

File Name : 4AM FINAL
 Site Code : 00000004
 Start Date : 6/6/2013
 Page No : 2

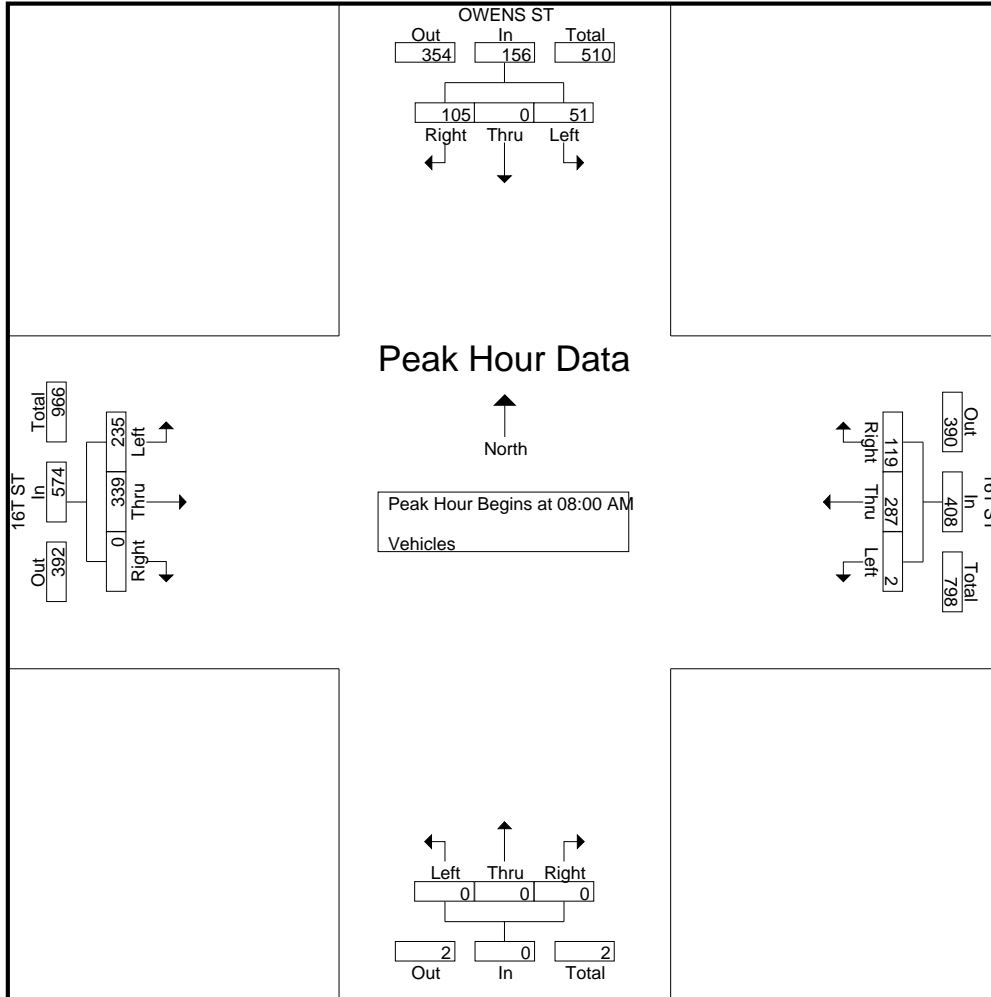

Traffic Data Service

Campbell, CA
(408) 377-2988
tdsbay@cs.com

File Name : 4AM FINAL
Site Code : 00000004
Start Date : 6/6/2013
Page No : 1

Groups Printed- Bikes

Start Time	OWENS ST Southbound					16T ST Westbound					Northbound					16T ST Eastbound					Int. Total
	Right	Thru	Left	Peds	App. Total	Right	Thru	Left	Peds	App. Total	Right	Thru	Left	Peds	App. Total	Right	Thru	Left	Peds	App. Total	
07:00 AM	1	0	0	0	1	0	0	0	0	0	0	0	0	0	0	0	1	1	0	2	3
07:15 AM	1	0	0	0	1	0	0	0	0	0	0	0	0	0	0	0	4	0	0	4	5
07:30 AM	2	0	0	0	2	0	1	0	0	1	0	0	0	0	0	0	3	1	0	4	7
07:45 AM	0	0	0	0	0	0	3	0	0	3	0	0	0	0	0	0	5	2	0	7	10
Total	4	0	0	0	4	0	4	0	0	4	0	0	0	0	0	0	13	4	0	17	25
08:00 AM	0	0	0	0	0	0	1	0	0	1	0	0	0	0	0	0	1	5	0	6	7
08:15 AM	0	0	0	0	0	0	1	0	0	1	0	0	0	0	0	0	6	4	0	10	11
08:30 AM	0	0	0	0	0	0	1	0	0	1	0	0	0	0	0	0	14	7	0	21	22
08:45 AM	0	0	0	0	0	0	2	0	0	2	0	0	0	0	0	0	12	8	0	20	22
Total	0	0	0	0	0	0	5	0	0	5	0	0	0	0	0	0	33	24	0	57	62
Grand Total	4	0	0	0	4	0	9	0	0	9	0	0	0	0	0	0	46	28	0	74	87
Apprch %	100	0	0	0		0	100	0	0		0	0	0	0		0	62.2	37.8	0		
Total %	4.6	0	0	0	4.6	0	10.3	0	0	10.3	0	0	0	0	0	0	52.9	32.2	0	85.1	

Start Time	OWENS ST Southbound					16T ST Westbound					Northbound					16T ST Eastbound					Int. Total
	Right	Thru	Left	Peds	App. Total	Right	Thru	Left	Peds	App. Total	Right	Thru	Left	Peds	App. Total	Right	Thru	Left	Peds	App. Total	
Peak Hour Analysis From 07:00 AM to 08:45 AM - Peak 1 of 1																					
Peak Hour for Entire Intersection Begins at 08:00 AM																					
08:00 AM	0	0	0	0	0	0	1	0	0	1	0	0	0	0	0	0	1	5	0	6	7
08:15 AM	0	0	0	0	0	0	1	0	0	1	0	0	0	0	0	0	6	4	0	10	11
08:30 AM	0	0	0	0	0	0	1	0	0	1	0	0	0	0	0	0	14	7	0	21	22
08:45 AM	0	0	0	0	0	0	2	0	0	2	0	0	0	0	0	0	12	8	0	20	22
Total Volume	0	0	0	0	0	0	5	0	0	5	0	0	0	0	0	0	33	24	0	57	62
% App. Total	0	0	0	0		0	100	0	0		0	0	0	0		0	57.9	42.1	0		
PHF	.000	.000	.000	.000	.000	.000	.625	.000	.000	.625	.000	.000	.000	.000	.000	.000	.589	.750	.679	.705	

Traffic Data Service

Campbell, CA

(408) 377-2988

tdsbay@cs.com

File Name : 4AM FINAL

Site Code : 00000004

Start Date : 6/6/2013

Page No : 2

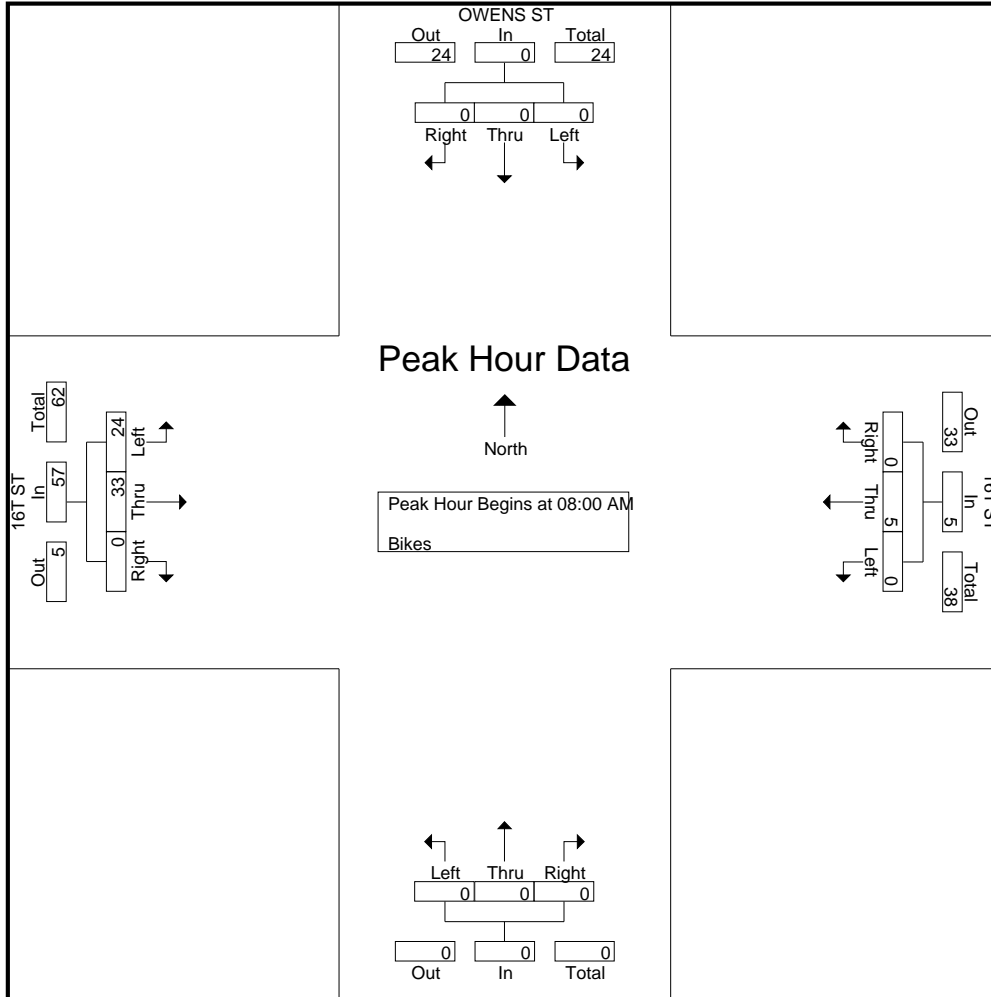

Traffic Data Service

Campbell, CA
 (408) 377-2988
 tdsbay@cs.com

File Name : 4PM FINAL
 Site Code : 00000004
 Start Date : 6/6/2013
 Page No : 1

Groups Printed- Vehicles

Start Time	OWENS ST Southbound					16T ST Westbound					Northbound					16T ST Eastbound					Int. Total
	Right	Thru	Left	Peds	App. Total	Right	Thru	Left	Peds	App. Total	Right	Thru	Left	Peds	App. Total	Right	Thru	Left	Peds	App. Total	
04:00 PM	39	0	14	2	55	12	131	0	0	143	0	0	0	0	0	0	69	22	1	92	290
04:15 PM	24	0	11	1	36	12	82	0	1	95	0	0	0	0	0	0	85	18	0	103	234
04:30 PM	40	0	15	8	63	14	101	0	0	115	0	0	0	0	0	0	80	24	2	106	284
04:45 PM	41	0	25	2	68	17	91	0	0	108	0	0	0	0	0	0	61	26	0	87	263
Total	144	0	65	13	222	55	405	0	1	461	0	0	0	0	0	0	295	90	3	388	1071
05:00 PM	51	0	29	0	80	23	121	0	0	144	0	0	0	0	0	0	91	37	0	128	352
05:15 PM	40	0	21	3	64	26	113	0	0	139	0	0	0	0	0	0	79	22	1	102	305
05:30 PM	32	0	20	1	53	19	117	0	0	136	0	0	0	0	0	0	86	32	0	118	307
05:45 PM	36	0	23	2	61	14	128	0	0	142	0	0	0	0	0	0	77	17	0	94	297
Total	159	0	93	6	258	82	479	0	0	561	0	0	0	0	0	0	333	108	1	442	1261
Grand Total	303	0	158	19	480	137	884	0	1	1022	0	0	0	0	0	0	628	198	4	830	2332
Apprch %	63.1	0	32.9	4		13.4	86.5	0	0.1		0	0	0	0	0	0	75.7	23.9	0.5		
Total %	13	0	6.8	0.8	20.6	5.9	37.9	0	0	43.8	0	0	0	0	0	0	26.9	8.5	0.2	35.6	

Start Time	OWENS ST Southbound				16T ST Westbound				Northbound				16T ST Eastbound				Int. Total
	Right	Thru	Left	App. Total	Right	Thru	Left	App. Total	Right	Thru	Left	App. Total	Right	Thru	Left	App. Total	
Peak Hour Analysis From 04:00 PM to 05:45 PM - Peak 1 of 1																	
Peak Hour for Entire Intersection Begins at 05:00 PM																	
05:00 PM	51	0	29	80	23	121	0	144	0	0	0	0	0	91	37	128	352
05:15 PM	40	0	21	61	26	113	0	139	0	0	0	0	0	79	22	101	301
05:30 PM	32	0	20	52	19	117	0	136	0	0	0	0	0	86	32	118	306
05:45 PM	36	0	23	59	14	128	0	142	0	0	0	0	0	77	17	94	295
Total Volume	159	0	93	252	82	479	0	561	0	0	0	0	0	333	108	441	1254
% App. Total	63.1	0	36.9		14.6	85.4	0		0	0	0	0	0	75.5	24.5		
PHF	.779	.000	.802	.788	.788	.936	.000	.974	.000	.000	.000	.000	.000	.915	.730	.861	.891

Traffic Data Service

Campbell, CA

(408) 377-2988

tdsbay@cs.com

File Name : 4PM FINAL

Site Code : 00000004

Start Date : 6/6/2013

Page No : 2

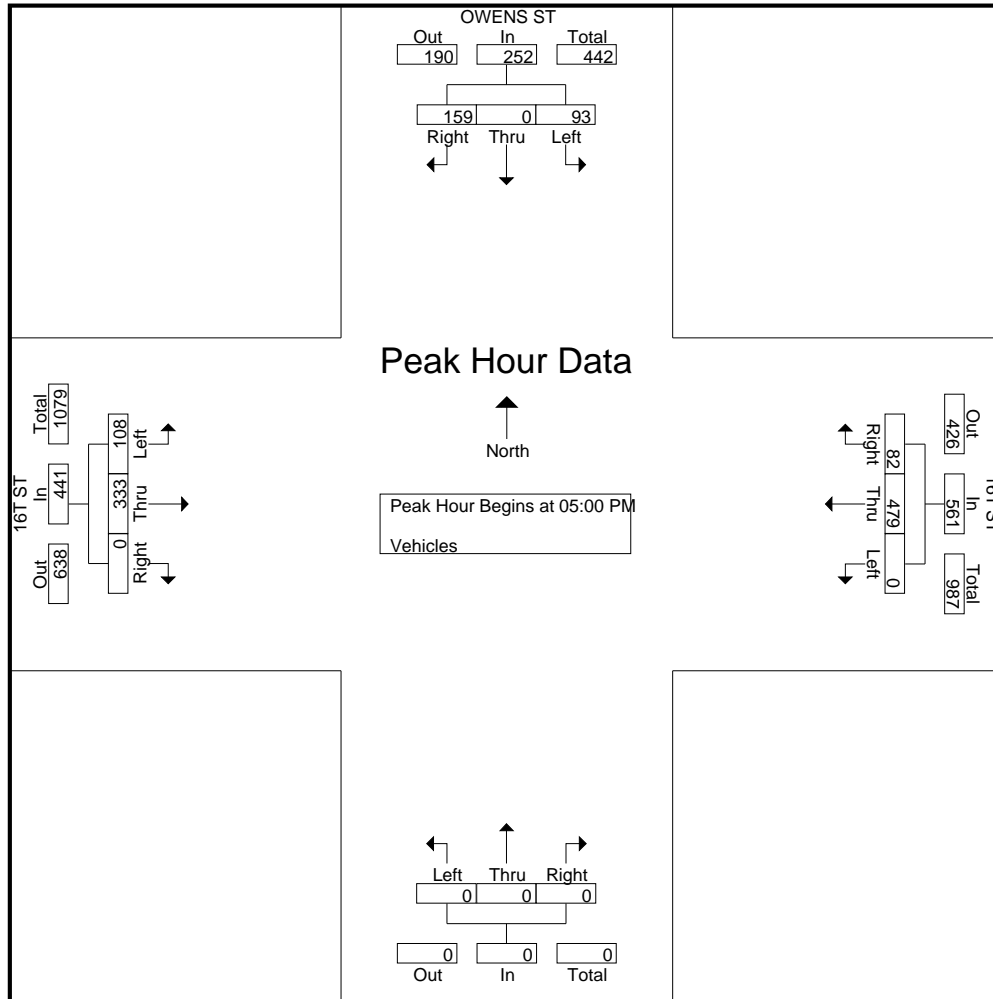

Traffic Data Service

Campbell, CA
 (408) 377-2988
 tdsbay@cs.com

File Name : 4PM FINAL
 Site Code : 00000004
 Start Date : 6/6/2013
 Page No : 1

Groups Printed- Bikes

Start Time	OWENS ST Southbound					16T ST Westbound					Northbound					16T ST Eastbound					Int. Total
	Right	Thru	Left	Peds	App. Total	Right	Thru	Left	Peds	App. Total	Right	Thru	Left	Peds	App. Total	Right	Thru	Left	Peds	App. Total	
04:00 PM	0	0	0	0	0	0	2	0	0	2	0	0	0	0	0	0	1	1	0	2	4
04:15 PM	3	0	0	0	3	0	6	0	0	6	0	0	0	0	0	0	2	0	0	2	11
04:30 PM	1	0	0	0	1	0	3	0	0	3	0	0	0	0	0	0	4	0	0	4	8
04:45 PM	2	0	0	0	2	0	6	0	0	6	0	0	0	0	0	0	2	0	0	2	10
Total	6	0	0	0	6	0	17	0	0	17	0	0	0	0	0	0	9	1	0	10	33
05:00 PM	3	0	0	0	3	0	5	0	0	5	0	0	0	0	0	0	3	0	0	3	11
05:15 PM	2	0	0	0	2	0	8	0	0	8	0	0	0	0	0	0	1	0	0	1	11
05:30 PM	6	0	0	0	6	0	13	0	0	13	0	0	0	0	0	0	6	0	0	6	25
05:45 PM	6	0	1	0	7	0	15	0	0	15	0	0	0	0	0	0	4	0	0	4	26
Total	17	0	1	0	18	0	41	0	0	41	0	0	0	0	0	0	14	0	0	14	73
Grand Total	23	0	1	0	24	0	58	0	0	58	0	0	0	0	0	0	23	1	0	24	106
Apprch %	95.8	0	4.2	0		0	100	0	0		0	0	0	0		0	95.8	4.2	0		
Total %	21.7	0	0.9	0	22.6	0	54.7	0	0	54.7	0	0	0	0	0	0	21.7	0.9	0	22.6	

Start Time	OWENS ST Southbound					16T ST Westbound					Northbound					16T ST Eastbound					Int. Total
	Right	Thru	Left	Peds	App. Total	Right	Thru	Left	Peds	App. Total	Right	Thru	Left	Peds	App. Total	Right	Thru	Left	Peds	App. Total	
05:00 PM	3	0	0	0	3	0	5	0	0	5	0	0	0	0	0	0	3	0	0	3	11
05:15 PM	2	0	0	0	2	0	8	0	0	8	0	0	0	0	0	0	1	0	0	1	11
05:30 PM	6	0	0	0	6	0	13	0	0	13	0	0	0	0	0	0	6	0	0	6	25
05:45 PM	6	0	1	0	7	0	15	0	0	15	0	0	0	0	0	0	4	0	0	4	26
Total Volume	17	0	1	0	18	0	41	0	0	41	0	0	0	0	0	0	14	0	0	14	73
% App. Total	94.4	0	5.6	0		0	100	0	0		0	0	0	0		0	100	0	0		
PHF	.708	.000	.250	.643		.000	.683	.000	.683		.000	.000	.000	.000		.000	.583	.000	.583		.702

Peak Hour Analysis From 04:00 PM to 05:45 PM - Peak 1 of 1

Peak Hour for Entire Intersection Begins at 05:00 PM

Traffic Data Service

Campbell, CA

(408) 377-2988

tdsbay@cs.com

File Name : 4PM FINAL

Site Code : 00000004

Start Date : 6/6/2013

Page No : 2

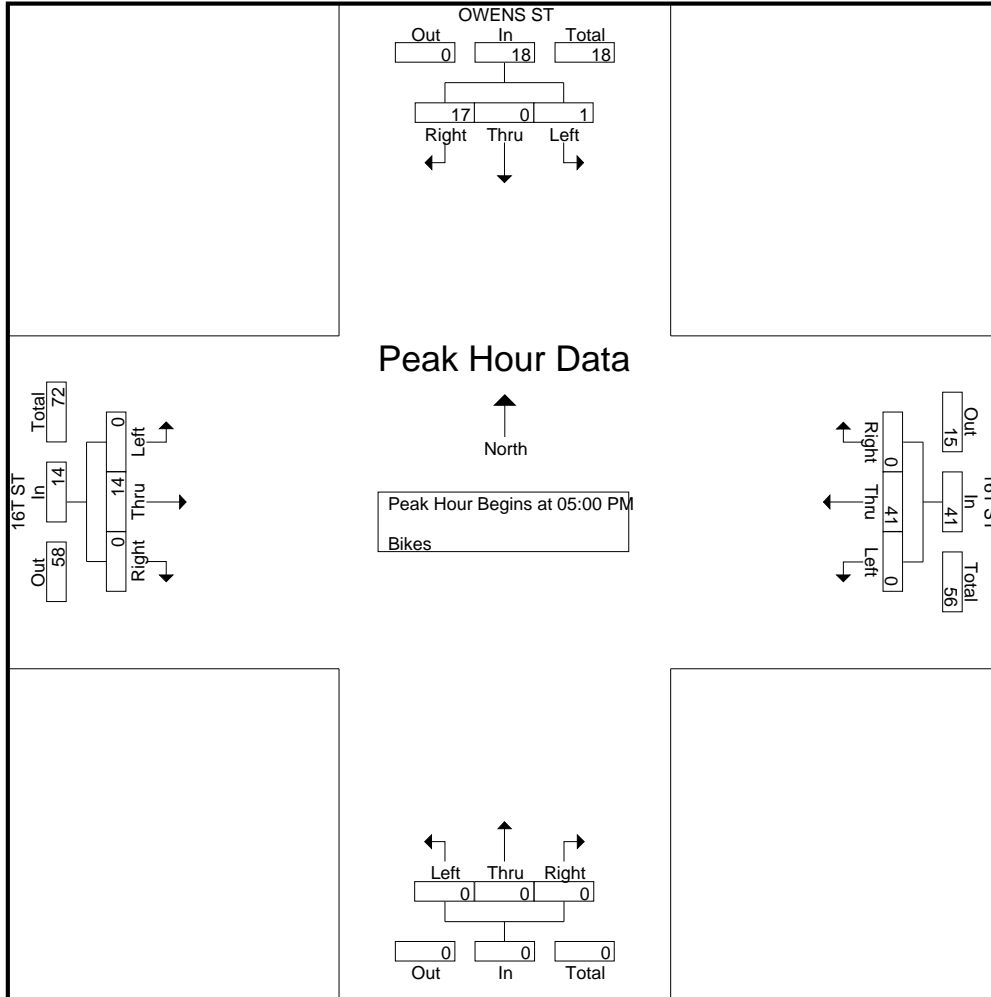

INTERSECTION CAR/PED/BIKE TRAFFIC COUNT RESULTS SUMMARY

CLIENT: FEHR & PEERS
 PROJECT: CALTRAIN TRAFFIC COUNTS
 DATE: WEDNESDAY MAY 22, 2013
 PERIOD: 7:00 AM TO 9:00 AM
 INTERSECTION: N/S PENNSYLVANIA STREET
 E/W 22ND STREET
 CITY: SAN FRANCISCO

VEHICLE COUNTS													
15 MIN COUNTS	1	2	3	4	5	6	7	8	9	10	11	12	
PERIOD	SBRT	SBTH	SBLT	WBRT	WBTH	WBLT	NBRT	NBTH	NBLT	EBRT	EBTH	EBLT	TOTAL
700-715	2	7	7	1	4	17	13	10	4	16	7	2	90
715-730	1	12	2	1	1	19	22	14	9	9	9	1	100
730-745	1	19	4	4	1	8	16	21	4	14	11	1	104
745-800	3	22	3	2	4	9	20	22	6	18	6	2	117
800-815	4	22	6	3	3	13	25	32	12	17	6	3	146
815-830	0	17	8	5	4	15	6	53	12	24	3	0	147
830-845	3	14	7	2	5	17	13	39	15	13	6	2	136
845-900	3	17	5	6	9	16	13	38	13	10	6	1	137
HOUR TOTALS	1	2	3	4	5	6	7	8	9	10	11	12	
PERIOD	SBRT	SBTH	SBLT	WBRT	WBTH	WBLT	NBRT	NBTH	NBLT	EBRT	EBTH	EBLT	TOTAL
700-800	7	60	16	8	10	53	71	67	23	57	33	6	411
715-815	9	75	15	10	9	49	83	89	31	58	32	7	467
730-830	8	80	21	14	12	45	67	128	34	73	26	6	514
745-845	10	75	24	12	16	54	64	146	45	72	21	7	546
800-900	10	70	26	16	21	61	57	162	52	64	21	6	566

AM PEAK HOUR: 800-900

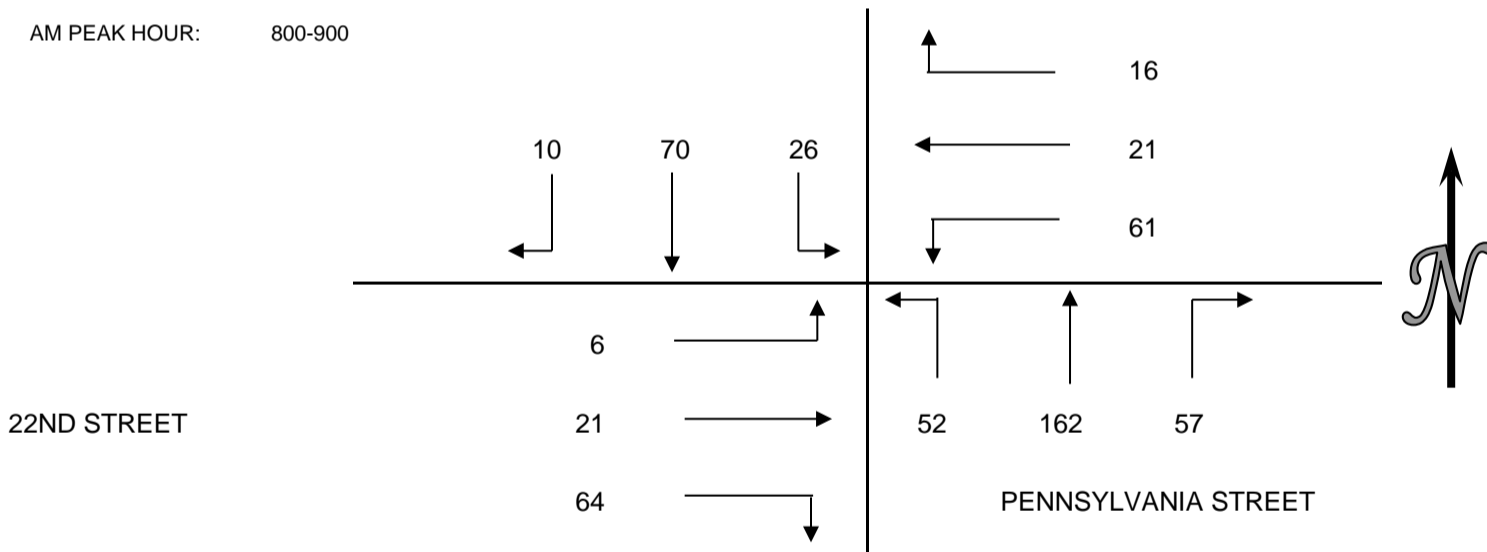

PEDESTRIAN COUNTS					
15 MIN COUNTS	NORTH LEG	EAST LEG	SOUTH LEG	WEST LEG	TOTAL
PERIOD	LEG	LEG	LEG	LEG	
700-715	5	6	23	2	36
715-730	6	5	18	1	30
730-745	4	3	13	1	21
745-800	6	12	21	3	42
800-815	7	4	10	2	23
815-830	12	8	29	3	52
830-845	12	12	14	1	39
845-900	10	2	30	0	42
HOUR TOTALS	NORTH LEG	EAST LEG	SOUTH LEG	WEST LEG	TOTAL
PERIOD	LEG	LEG	LEG	LEG	
700-800	21	26	75	7	129
715-815	23	24	62	7	116
730-830	29	27	73	9	138
745-845	37	36	74	9	156
800-900	41	26	83	6	156

BICYCLE COUNTS					
15 MIN COUNTS	NORTH LEG	EAST LEG	SOUTH LEG	WEST LEG	TOTAL
PERIOD	LEG	LEG	LEG	LEG	
700-715	1	0	2	0	3
715-730	0	0	2	1	3
730-745	0	0	1	0	1
745-800	0	0	3	0	3
800-815	0	2	3	0	5
815-830	0	0	1	0	1
830-845	0	0	3	0	3
845-900	0	0	6	0	6
HOUR TOTALS	NORTH LEG	EAST LEG	SOUTH LEG	WEST LEG	TOTAL
PERIOD	LEG	LEG	LEG	LEG	
700-800	1	0	8	1	10
715-815	0	2	9	1	12
730-830	0	2	8	0	10
745-845	0	2	10	0	12
800-900	0	2	13	0	15

INTERSECTION CAR/PED/BIKE TRAFFIC COUNT RESULTS SUMMARY

CLIENT: FEHR & PEERS
 PROJECT: CALTRAIN TRAFFIC COUNTS
 DATE: WEDNESDAY MAY 22, 2013
 PERIOD: 4:00 PM TO 6:00 PM
 INTERSECTION: N/S PENNSYLVANIA STREET
 E/W 22ND STREET
 CITY: SAN FRANCISCO

VEHICLE COUNTS													
15 MIN COUNTS	1	2	3	4	5	6	7	8	9	10	11	12	
PERIOD	SBRT	SBTH	SBLT	WBRT	WBTH	WBLT	NBRT	NBTH	NBLT	EBRT	EBTH	EBLT	TOTAL
400-415	2	20	4	3	5	22	5	43	9	10	4	0	127
415-430	1	13	3	4	1	20	7	40	9	13	2	1	114
430-445	1	15	2	5	5	27	9	45	12	14	4	3	142
445-500	2	15	1	6	4	31	15	69	11	11	5	1	171
500-515	1	24	3	3	8	25	8	37	16	15	9	0	149
515-530	0	22	2	8	8	26	7	29	11	28	10	2	153
530-545	0	39	5	7	7	20	8	43	7	13	6	1	156
545-600	3	57	6	2	6	22	11	36	15	12	0	0	170
HOUR TOTALS	1	2	3	4	5	6	7	8	9	10	11	12	
PERIOD	SBRT	SBTH	SBLT	WBRT	WBTH	WBLT	NBRT	NBTH	NBLT	EBRT	EBTH	EBLT	TOTAL
400-500	6	63	10	18	15	100	36	197	41	48	15	5	554
415-515	5	67	9	18	18	103	39	191	48	53	20	5	576
430-530	4	76	8	22	25	109	39	180	50	68	28	6	615
445-545	3	100	11	24	27	102	38	178	45	67	30	4	629
500-600	4	142	16	20	29	93	34	145	49	68	25	3	628

AM PEAK HOUR: 445-545

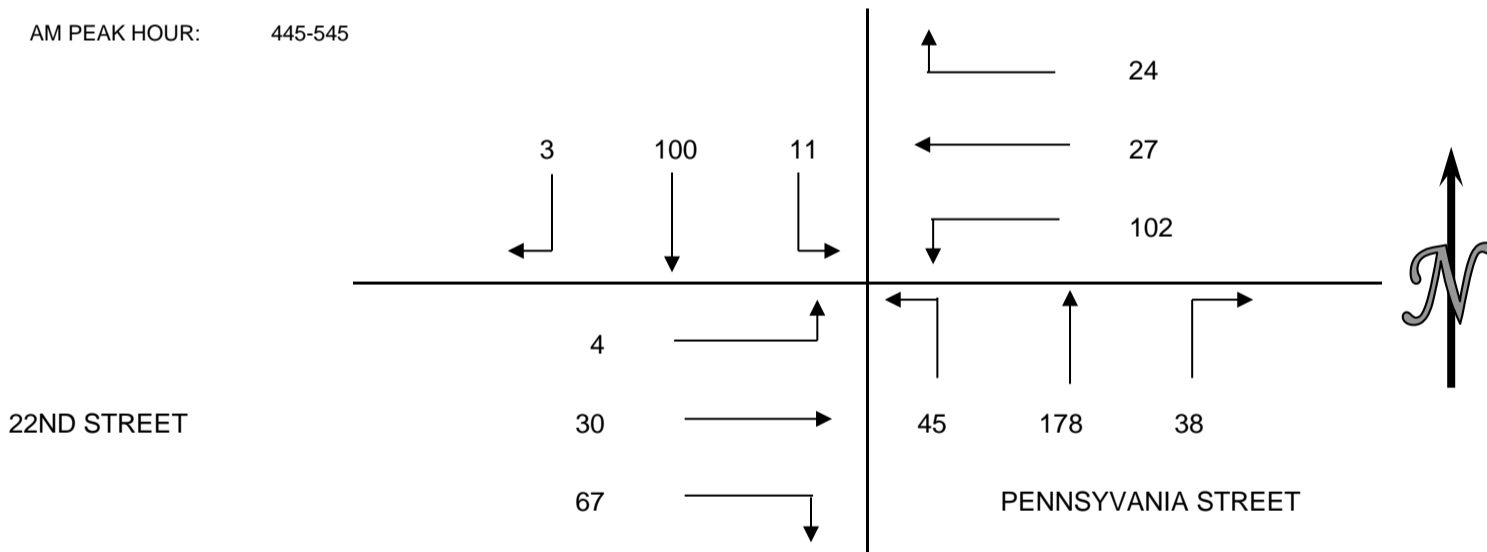

PEDESTRIAN COUNTS					
15 MIN COUNTS	NORTH LEG	EAST LEG	SOUTH LEG	WEST LEG	TOTAL
PERIOD	LEG	LEG	LEG	LEG	
400-415	4	1	2	0	7
415-430	3	1	3	1	8
430-445	13	1	6	2	22
445-500	0	2	14	0	16
500-515	1	0	2	0	3
515-530	9	5	18	4	36
530-545	7	10	14	2	33
545-600	6	4	10	0	20
HOUR TOTALS	NORTH LEG	EAST LEG	SOUTH LEG	WEST LEG	TOTAL
PERIOD	LEG	LEG	LEG	LEG	
400-500	20	5	25	3	53
415-515	17	4	25	3	49
430-530	23	8	40	6	77
445-545	17	17	48	6	88
500-600	23	19	44	6	92

BICYCLE COUNTS					
15 MIN COUNTS	NORTH LEG	EAST LEG	SOUTH LEG	WEST LEG	TOTAL
PERIOD	LEG	LEG	LEG	LEG	
400-415	0	0	0	0	0
415-430	1	1	2	1	5
430-445	1	0	1	0	2
445-500	1	0	0	0	1
500-515	3	0	0	0	3
515-530	4	0	0	0	4
530-545	3	0	2	1	6
545-600	1	0	0	0	1
HOUR TOTALS	NORTH LEG	EAST LEG	SOUTH LEG	WEST LEG	TOTAL
PERIOD	LEG	LEG	LEG	LEG	
400-500	3	1	3	1	8
415-515	6	1	3	1	11
430-530	9	0	1	0	10
445-545	11	0	2	1	14
500-600	11	0	2	1	14

INTERSECTION CAR/PED/BIKE TRAFFIC COUNT RESULTS SUMMARY

CLIENT: FEHR & PEERS
 PROJECT: CALTRAIN TRAFFIC COUNTS
 DATE: WEDNESDAY MAY 22, 2013
 PERIOD: 7:00 AM TO 9:00 AM
 INTERSECTION: N/S 22ND STREET
 E/W INDIANA STREET
 CITY: SAN FRANCISCO

VEHICLE COUNTS													
15 MIN COUNTS	1	2	3	4	5	6	7	8	9	10	11	12	
PERIOD	SBRT	SBTH	SBLT	WBRT	WBTH	WBLT	NBRT	NBTH	NBLT	EBRT	EBTH	EBLT	TOTAL
700-715	3	2	2	2	15	2	9	5	4	5	11	7	67
715-730	1	4	2	1	21	4	7	15	1	2	14	4	76
730-745	4	2	2	0	17	4	7	9	0	6	12	4	67
745-800	3	4	6	2	16	1	12	10	2	4	15	6	81
800-815	3	4	1	2	14	0	8	11	3	3	17	6	72
815-830	2	7	2	0	16	1	6	15	2	2	15	4	72
830-845	2	2	0	2	25	1	16	21	3	4	21	2	99
845-900	4	4	0	2	16	5	14	11	5	6	26	6	99
HOUR TOTALS	1	2	3	4	5	6	7	8	9	10	11	12	
PERIOD	SBRT	SBTH	SBLT	WBRT	WBTH	WBLT	NBRT	NBTH	NBLT	EBRT	EBTH	EBLT	TOTAL
700-800	11	12	12	5	69	11	35	39	7	17	52	21	291
715-815	11	14	11	5	68	9	34	45	6	15	58	20	296
730-830	12	17	11	4	63	6	33	45	7	15	59	20	292
745-845	10	17	9	6	71	3	42	57	10	13	68	18	324
800-900	11	17	3	6	71	7	44	58	13	15	79	18	342

AM PEAK HOUR: 800-900

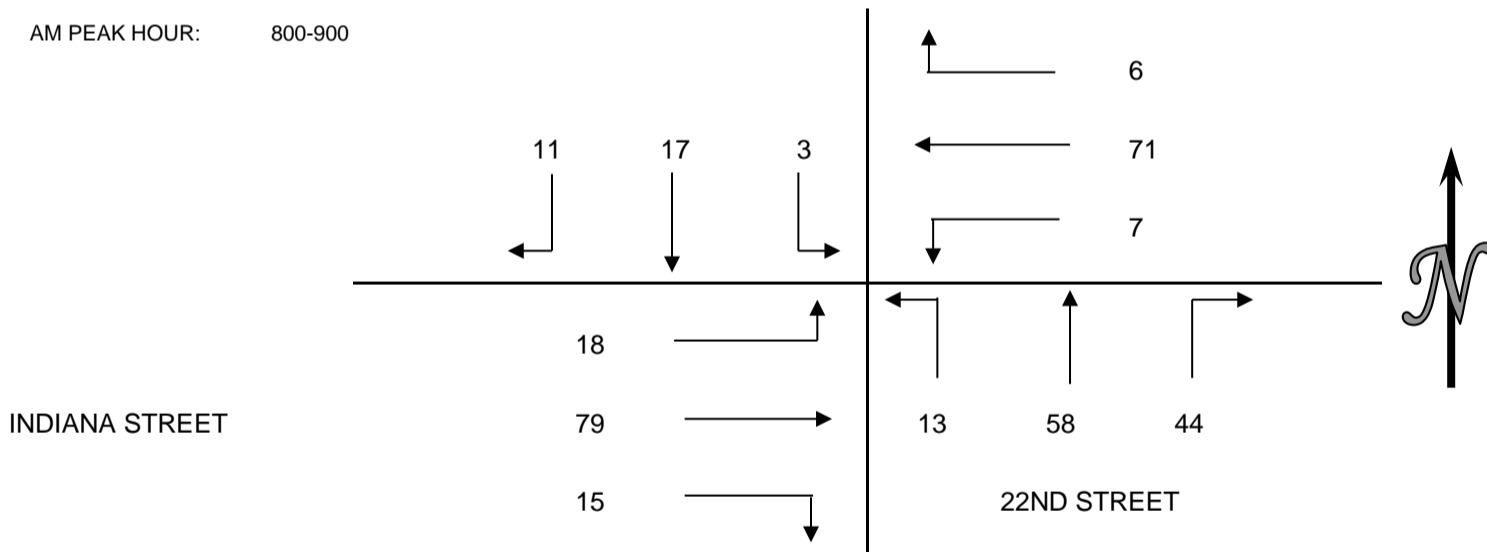

PEDESTRIAN COUNTS					
15 MIN COUNTS	NORTH LEG	EAST LEG	SOUTH LEG	WEST LEG	TOTAL
PERIOD	LEG	LEG	LEG	LEG	
700-715	6	3	13	6	28
715-730	8	0	8	1	17
730-745	12	6	12	4	34
745-800	8	5	14	4	31
800-815	9	2	18	3	32
815-830	8	5	4	2	19
830-845	14	4	27	7	52
845-900	11	5	13	3	32
HOUR TOTALS	NORTH LEG	EAST LEG	SOUTH LEG	WEST LEG	TOTAL
PERIOD	LEG	LEG	LEG	LEG	
700-800	34	14	47	15	110
715-815	37	13	52	12	114
730-830	37	18	48	13	116
745-845	39	16	63	16	134
800-900	42	16	62	15	135

BICYCLE COUNTS					
15 MIN COUNTS	NORTH LEG	EAST LEG	SOUTH LEG	WEST LEG	TOTAL
PERIOD	LEG	LEG	LEG	LEG	
700-715	1	1	2	1	5
715-730	2	0	0	0	2
730-745	2	2	4	0	8
745-800	3	3	6	1	13
800-815	2	0	2	1	5
815-830	1	4	4	1	10
830-845	0	7	6	1	14
845-900	4	1	3	3	11
HOUR TOTALS	NORTH LEG	EAST LEG	SOUTH LEG	WEST LEG	TOTAL
PERIOD	LEG	LEG	LEG	LEG	
700-800	8	6	12	2	28
715-815	9	5	12	2	28
730-830	8	9	16	3	36
745-845	6	14	18	4	42
800-900	7	12	15	6	40

INTERSECTION CAR/PED/BIKE TRAFFIC COUNT RESULTS SUMMARY

CLIENT: FEHR & PEERS
 PROJECT: CALTRAIN TRAFFIC COUNTS
 DATE: WEDNESDAY MAY 22, 2013
 PERIOD: 4:00 PM TO 6:00 PM
 INTERSECTION: N/S 22ND STREET
 E/W INDIAN STREET
 CITY: SAN FRANCISCO

VEHICLE COUNTS													
15 MIN COUNTS	1	2	3	4	5	6	7	8	9	10	11	12	
PERIOD	SBRT	SBTH	SBLT	WBRT	WBTH	WBLT	NBRT	NBTH	NBLT	EBRT	EBTH	EBLT	TOTAL
400-415	4	7	4	2	22	2	8	12	2	1	19	4	87
415-430	4	4	1	1	15	3	7	16	1	2	11	0	65
430-445	9	1	3	4	18	2	10	19	5	3	15	2	91
445-500	7	2	1	0	29	1	10	17	5	3	19	0	94
500-515	6	2	3	1	23	1	20	16	6	3	21	1	103
515-530	6	7	1	1	28	2	14	15	1	3	18	8	104
530-545	10	6	3	0	24	3	5	12	4	1	12	3	83
545-600	7	5	3	2	24	5	11	10	5	2	10	2	86
HOUR TOTALS	1	2	3	4	5	6	7	8	9	10	11	12	
PERIOD	SBRT	SBTH	SBLT	WBRT	WBTH	WBLT	NBRT	NBTH	NBLT	EBRT	EBTH	EBLT	TOTAL
400-500	24	14	9	7	84	8	35	64	13	9	64	6	337
415-515	26	9	8	6	85	7	47	68	17	11	66	3	353
430-530	28	12	8	6	98	6	54	67	17	12	73	11	392
445-545	29	17	8	2	104	7	49	60	16	10	70	12	384
500-600	29	20	10	4	99	11	50	53	16	9	61	14	376

AM PEAK HOUR: 430-530

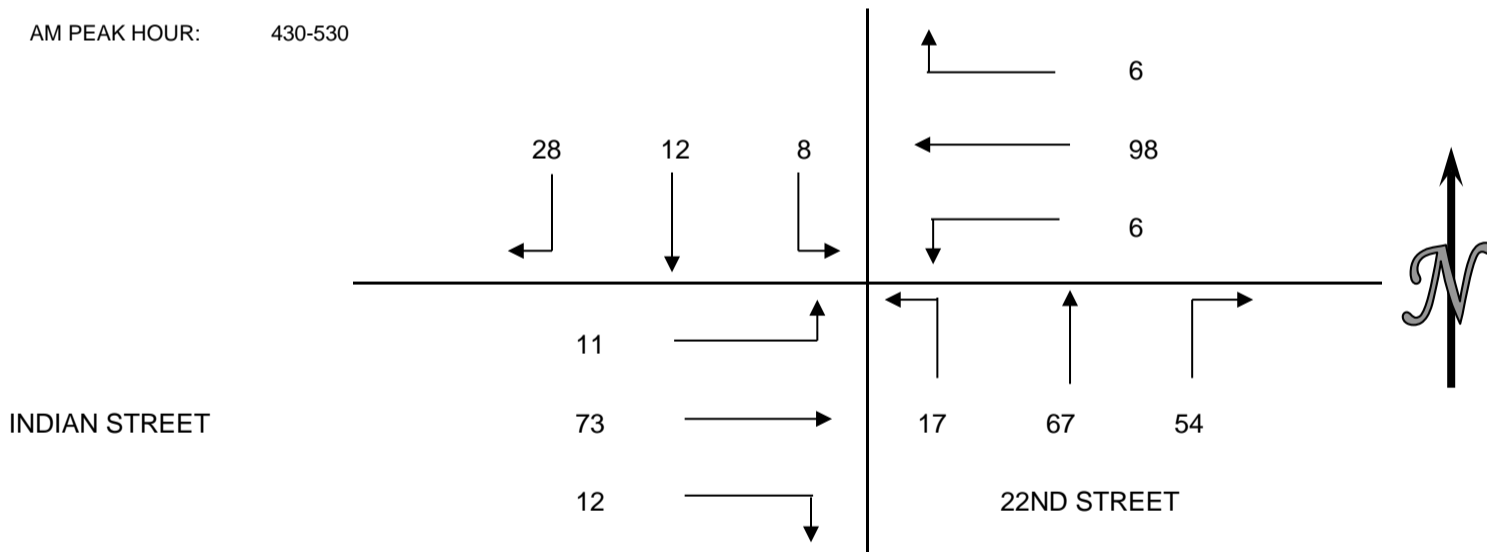

PEDESTRIAN COUNTS					
15 MIN COUNTS	NORTH LEG	EAST LEG	SOUTH LEG	WEST LEG	TOTAL
PERIOD	LEG	LEG	LEG	LEG	
400-415	6	0	5	1	12
415-430	9	0	10	2	21
430-445	8	1	6	1	16
445-500	8	6	15	5	34
500-515	2	4	6	0	12
515-530	15	4	17	3	39
530-545	11	2	8	11	32
545-600	5	3	14	4	26
HOUR TOTALS	NORTH LEG	EAST LEG	SOUTH LEG	WEST LEG	TOTAL
PERIOD	LEG	LEG	LEG	LEG	
400-500	31	7	36	9	83
415-515	27	11	37	8	83
430-530	33	15	44	9	101
445-545	36	16	46	19	117
500-600	33	13	45	18	109

BICYCLE COUNTS					
15 MIN COUNTS	NORTH LEG	EAST LEG	SOUTH LEG	WEST LEG	TOTAL
PERIOD	LEG	LEG	LEG	LEG	
400-415	0	4	2	1	7
415-430	3	1	0	0	4
430-445	0	2	3	0	5
445-500	0	9	12	4	25
500-515	1	2	4	0	7
515-530	4	9	9	0	22
530-545	3	2	5	1	11
545-600	2	7	5	1	15
HOUR TOTALS	NORTH LEG	EAST LEG	SOUTH LEG	WEST LEG	TOTAL
PERIOD	LEG	LEG	LEG	LEG	
400-500	3	16	17	5	41
415-515	4	14	19	4	41
430-530	5	22	28	4	59
445-545	8	22	30	5	65
500-600	10	20	23	2	55

Traffic Data Service

Campbell, CA
 (408) 377-2988
 tdsbay@cs.com

File Name : 1AM FINAL
 Site Code : 00000001
 Start Date : 9/24/2013
 Page No : 1

Groups Printed- Vehicles

Start Time	TUNNEL AVE Southbound					BLANKEN AVE Westbound					TUNNEL AVE Northbound					BLANKEN AVE Eastbound					Int. Total
	Right	Thru	Left	Peds	App. Total	Right	Thru	Left	Peds	App. Total	Right	Thru	Left	Peds	App. Total	Right	Thru	Left	Peds	App. Total	
07:00 AM	3	11	5	10	29	17	13	0	0	30	0	31	6	17	54	29	7	1	5	42	155
07:15 AM	4	23	10	4	41	9	16	3	8	36	3	38	15	25	81	40	20	1	2	63	221
07:30 AM	1	25	10	12	48	18	14	2	9	43	0	34	18	29	81	44	32	3	3	82	254
07:45 AM	2	22	11	0	35	16	20	8	3	47	1	20	13	16	50	43	48	2	0	93	225
Total	10	81	36	26	153	60	63	13	20	156	4	123	52	87	266	156	107	7	10	280	855
08:00 AM	4	21	11	1	37	15	18	0	3	36	6	30	6	20	62	51	21	2	1	75	210
08:15 AM	1	26	20	3	50	16	18	4	7	45	6	35	10	19	70	44	36	6	0	86	251
08:30 AM	0	29	14	11	54	20	16	5	2	43	2	33	12	9	56	43	38	0	4	85	238
08:45 AM	3	28	18	6	55	16	12	1	2	31	2	41	19	20	82	43	19	0	4	66	234
Total	8	104	63	21	196	67	64	10	14	155	16	139	47	68	270	181	114	8	9	312	933
Grand Total	18	185	99	47	349	127	127	23	34	311	20	262	99	155	536	337	221	15	19	592	1788
Apprch %	5.2	53	28.4	13.5		40.8	40.8	7.4	10.9		3.7	48.9	18.5	28.9		56.9	37.3	2.5	3.2		
Total %	1	10.3	5.5	2.6	19.5	7.1	7.1	1.3	1.9	17.4	1.1	14.7	5.5	8.7	30	18.8	12.4	0.8	1.1	33.1	

Start Time	TUNNEL AVE Southbound				BLANKEN AVE Westbound				TUNNEL AVE Northbound				BLANKEN AVE Eastbound				Int. Total
	Right	Thru	Left	App. Total	Right	Thru	Left	App. Total	Right	Thru	Left	App. Total	Right	Thru	Left	App. Total	
Peak Hour Analysis From 07:00 AM to 08:45 AM - Peak 1 of 1																	
Peak Hour for Entire Intersection Begins at 07:45 AM																	
07:45 AM	2	22	11	35	16	20	8	44	1	20	13	34	43	48	2	93	206
08:00 AM	4	21	11	36	15	18	0	33	6	30	6	42	51	21	2	74	185
08:15 AM	1	26	20	47	16	18	4	38	6	35	10	51	44	36	6	86	222
08:30 AM	0	29	14	43	20	16	5	41	2	33	12	47	43	38	0	81	212
Total Volume	7	98	56	161	67	72	17	156	15	118	41	174	181	143	10	334	825
% App. Total	4.3	60.9	34.8		42.9	46.2	10.9		8.6	67.8	23.6		54.2	42.8	3		
PHF	.438	.845	.700	.856	.838	.900	.531	.886	.625	.843	.788	.853	.887	.745	.417	.898	.929

Traffic Data Service

Campbell, CA
 (408) 377-2988
 tdsbay@cs.com

File Name : 1AM FINAL
 Site Code : 00000001
 Start Date : 9/24/2013
 Page No : 2

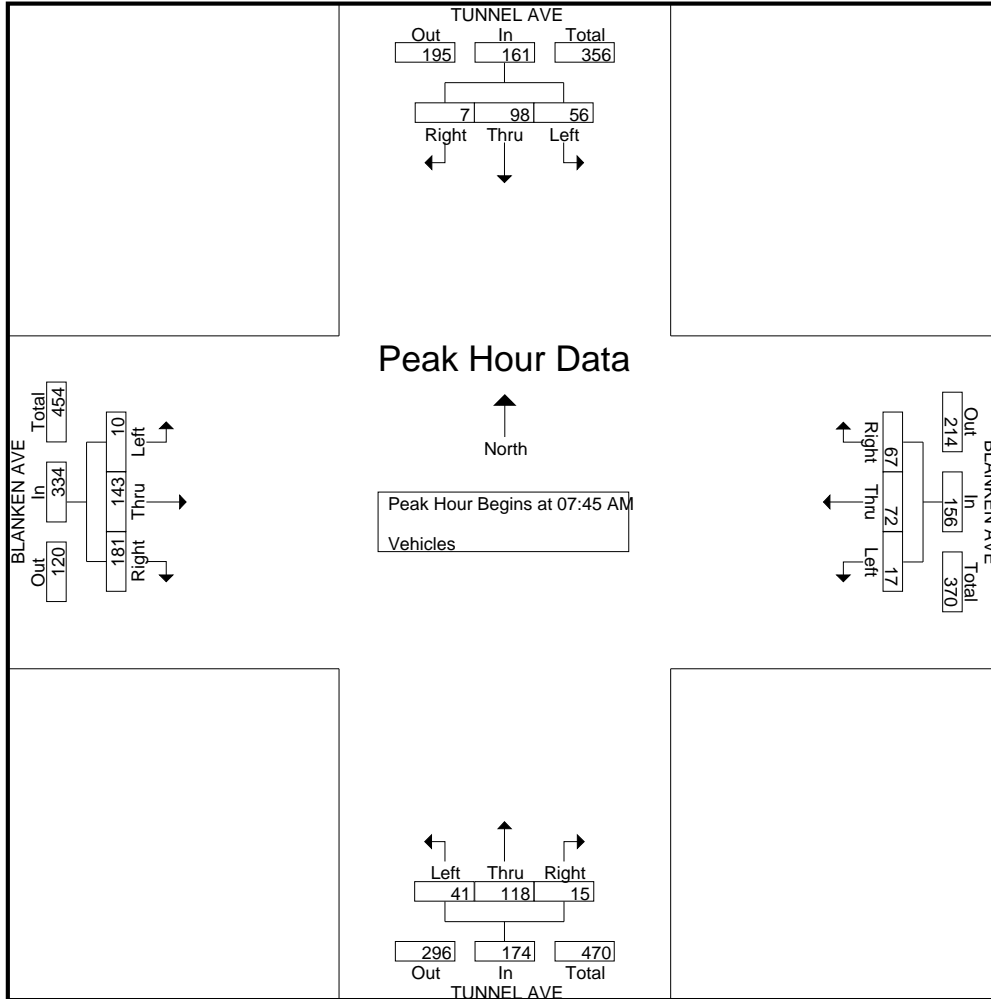

Traffic Data Service

Campbell, CA
 (408) 377-2988
 tdsbay@cs.com

File Name : 1AM FINAL
 Site Code : 00000001
 Start Date : 9/24/2013
 Page No : 1

Groups Printed- Bikes

Start Time	TUNNEL AVE Southbound					BLANKEN AVE Westbound					TUNNEL AVE Northbound					BLANKEN AVE Eastbound					Int. Total					
	Right	Thru	Left	Peds	App. Total	Right	Thru	Left	Peds	App. Total	Right	Thru	Left	Peds	App. Total	Right	Thru	Left	Peds	App. Total						
07:00 AM	0	0	0	0	0	0	0	0	0	0	0	0	0	0	0	0	0	0	0	0	0	0	0	0	0	0
07:15 AM	0	0	0	0	0	0	0	0	0	0	0	0	0	0	0	19	0	0	0	0	19	0	0	0	19	19
07:30 AM	0	0	0	0	0	0	0	0	0	0	0	0	0	0	0	2	0	0	0	0	2	0	0	0	2	2
07:45 AM	0	1	0	0	1	0	0	0	0	0	0	1	0	0	1	2	0	0	0	0	2	0	0	0	2	4
Total	0	1	0	0	1	0	0	0	0	0	0	1	0	0	1	23	0	0	0	0	23	0	0	0	23	25
08:00 AM	0	1	0	0	1	0	0	0	0	0	0	1	0	0	1	3	0	0	0	0	3	0	0	0	3	5
08:15 AM	0	0	0	0	0	0	0	0	0	0	0	1	1	0	2	5	0	0	0	0	5	0	0	0	5	7
08:30 AM	0	0	0	0	0	0	0	0	0	0	0	1	1	0	2	0	1	0	0	0	1	0	0	0	1	3
08:45 AM	0	2	0	0	2	0	0	0	0	0	0	1	0	0	1	2	0	0	0	0	2	0	0	0	2	5
Total	0	3	0	0	3	0	0	0	0	0	0	4	2	0	6	10	1	0	0	0	11	0	0	0	11	20
Grand Total	0	4	0	0	4	0	0	0	0	0	0	5	2	0	7	33	1	0	0	0	34	0	0	0	34	45
Apprch %	0	100	0	0		0	0	0	0		0	71.4	28.6	0		97.1	2.9	0	0							
Total %	0	8.9	0	0	8.9	0	0	0	0	0	0	11.1	4.4	0	15.6	73.3	2.2	0	0	75.6						

Start Time	TUNNEL AVE Southbound				BLANKEN AVE Westbound				TUNNEL AVE Northbound				BLANKEN AVE Eastbound				Int. Total
	Right	Thru	Left	App. Total	Right	Thru	Left	App. Total	Right	Thru	Left	App. Total	Right	Thru	Left	App. Total	
Peak Hour Analysis From 07:00 AM to 08:45 AM - Peak 1 of 1																	
Peak Hour for Entire Intersection Begins at 07:15 AM																	
07:15 AM	0	0	0	0	0	0	0	0	0	0	0	0	19	0	0	19	19
07:30 AM	0	0	0	0	0	0	0	0	0	0	0	0	2	0	0	2	2
07:45 AM	0	1	0	1	0	0	0	0	0	1	0	1	2	0	0	2	4
08:00 AM	0	1	0	1	0	0	0	0	0	1	0	1	3	0	0	3	5
Total Volume	0	2	0	2	0	0	0	0	0	2	0	2	26	0	0	26	30
% App. Total	0	100	0		0	0	0		0	100	0		100	0	0		
PHF	.000	.500	.000	.500	.000	.000	.000	.000	.000	.500	.000	.500	.342	.000	.000	.342	.395

Traffic Data Service

Campbell, CA

(408) 377-2988

tdsbay@cs.com

File Name : 1AM FINAL

Site Code : 00000001

Start Date : 9/24/2013

Page No : 2

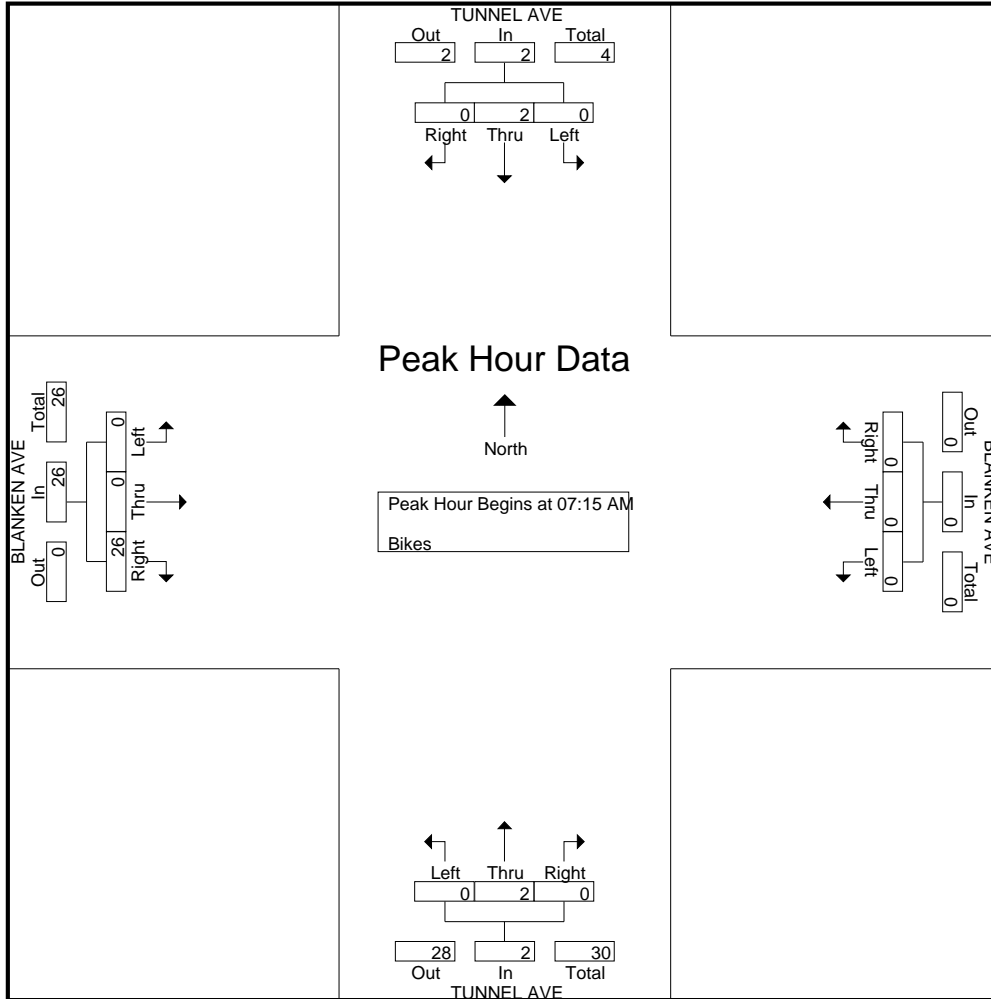

Traffic Data Service

Campbell, CA
 (408) 377-2988
 tdsbay@cs.com

File Name : 1PM FINAL
 Site Code : 00000001
 Start Date : 9/24/2013
 Page No : 1

Groups Printed- Vehicles

Start Time	TUNNEL AVE Southbound					BLANKEN AVE Westbound					TUNNEL AVE Northbound					BLANKEN AVE Eastbound					Int. Total
	Right	Thru	Left	Peds	App. Total	Right	Thru	Left	Peds	App. Total	Right	Thru	Left	Peds	App. Total	Right	Thru	Left	Peds	App. Total	
04:00 PM	3	16	15	4	38	11	13	1	6	31	1	28	4	13	46	20	6	2	1	29	144
04:15 PM	4	11	8	2	25	11	25	1	7	44	0	40	14	26	80	12	7	3	2	24	173
04:30 PM	0	10	14	1	25	18	23	0	2	43	0	32	12	23	67	20	12	2	0	34	169
04:45 PM	1	13	16	6	36	17	21	0	2	40	0	20	9	27	56	18	6	0	0	24	156
Total	8	50	53	13	124	57	82	2	17	158	1	120	39	89	249	70	31	7	3	111	642
05:00 PM	2	13	16	3	34	11	30	0	2	43	1	40	8	28	77	19	11	1	1	32	186
05:15 PM	1	13	18	4	36	22	37	3	2	64	1	39	7	12	59	20	9	0	3	32	191
05:30 PM	1	14	17	6	38	21	32	2	5	60	1	33	5	25	64	16	14	0	0	30	192
05:45 PM	4	12	14	4	34	19	20	3	4	46	2	26	4	16	48	20	18	2	1	41	169
Total	8	52	65	17	142	73	119	8	13	213	5	138	24	81	248	75	52	3	5	135	738
Grand Total	16	102	118	30	266	130	201	10	30	371	6	258	63	170	497	145	83	10	8	246	1380
Apprch %	6	38.3	44.4	11.3		35	54.2	2.7	8.1		1.2	51.9	12.7	34.2		58.9	33.7	4.1	3.3		
Total %	1.2	7.4	8.6	2.2	19.3	9.4	14.6	0.7	2.2	26.9	0.4	18.7	4.6	12.3	36	10.5	6	0.7	0.6	17.8	

Start Time	TUNNEL AVE Southbound				BLANKEN AVE Westbound				TUNNEL AVE Northbound				BLANKEN AVE Eastbound				Int. Total
	Right	Thru	Left	App. Total	Right	Thru	Left	App. Total	Right	Thru	Left	App. Total	Right	Thru	Left	App. Total	
05:00 PM	2	13	16	31	11	30	0	41	1	40	8	49	19	11	1	31	152
05:15 PM	1	13	18	32	22	37	3	62	1	39	7	47	20	9	0	29	170
05:30 PM	1	14	17	32	21	32	2	55	1	33	5	39	16	14	0	30	156
05:45 PM	4	12	14	30	19	20	3	42	2	26	4	32	20	18	2	40	144
Total Volume	8	52	65	125	73	119	8	200	5	138	24	167	75	52	3	130	622
% App. Total	6.4	41.6	52		36.5	59.5	4		3	82.6	14.4		57.7	40	2.3		
PHF	.500	.929	.903	.977	.830	.804	.667	.806	.625	.863	.750	.852	.938	.722	.375	.813	.915

Peak Hour Analysis From 04:00 PM to 05:45 PM - Peak 1 of 1

Peak Hour for Entire Intersection Begins at 05:00 PM

Traffic Data Service

Campbell, CA

(408) 377-2988

tdsbay@cs.com

File Name : 1PM FINAL

Site Code : 00000001

Start Date : 9/24/2013

Page No : 2

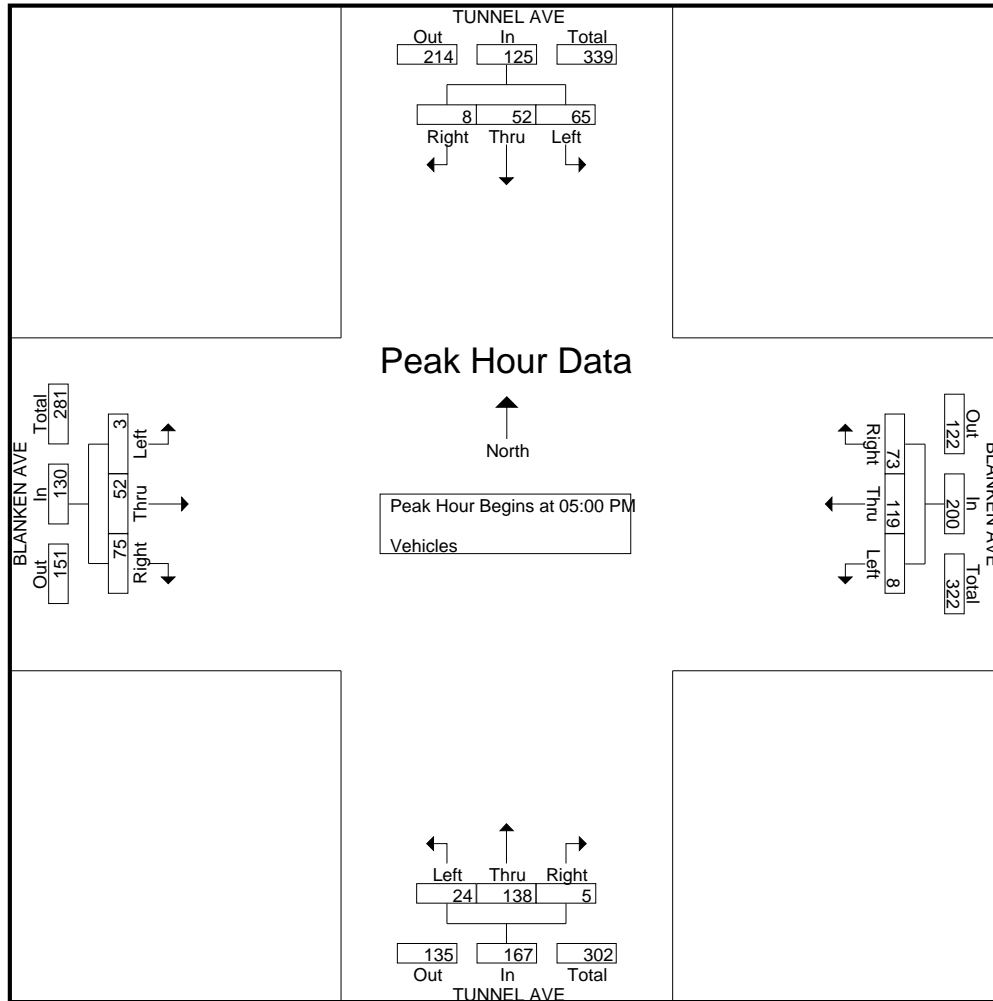

Traffic Data Service

Campbell, CA
 (408) 377-2988
 tdsbay@cs.com

File Name : 1PM FINAL
 Site Code : 00000001
 Start Date : 9/24/2013
 Page No : 1

Groups Printed- Bikes

Start Time	TUNNEL AVE Southbound					BLANKEN AVE Westbound					TUNNEL AVE Northbound					BLANKEN AVE Eastbound					Int. Total
	Right	Thru	Left	Peds	App. Total	Right	Thru	Left	Peds	App. Total	Right	Thru	Left	Peds	App. Total	Right	Thru	Left	Peds	App. Total	
04:00 PM	0	0	1	0	1	0	0	0	0	0	0	0	0	0	0	0	0	0	0	0	1
04:15 PM	0	0	0	0	0	0	0	0	0	0	0	0	0	0	0	1	0	0	0	0	1
04:30 PM	0	0	0	0	0	0	0	0	0	0	0	2	1	0	3	0	0	0	0	0	3
04:45 PM	0	0	0	0	0	0	0	0	0	0	0	2	1	0	3	0	0	0	0	0	3
Total	0	0	1	0	1	0	0	0	0	0	0	4	2	0	6	1	0	0	0	1	8
05:00 PM	0	0	0	0	0	0	0	0	0	0	0	0	1	0	1	1	0	0	0	1	2
05:15 PM	0	0	0	0	0	0	0	0	0	0	0	1	1	0	2	0	0	0	0	0	2
05:30 PM	0	0	0	0	0	0	0	0	0	0	0	4	0	0	4	1	0	0	0	1	5
05:45 PM	0	0	0	0	0	0	0	0	0	0	0	2	0	0	2	0	0	0	0	0	2
Total	0	0	0	0	0	0	0	0	0	0	0	7	2	0	9	2	0	0	0	2	11
Grand Total	0	0	1	0	1	0	0	0	0	0	0	11	4	0	15	3	0	0	0	3	19
Apprch %	0	0	100	0		0	0	0	0		0	73.3	26.7	0		100	0	0	0		
Total %	0	0	5.3	0	5.3	0	0	0	0	0	0	57.9	21.1	0	78.9	15.8	0	0	0	15.8	

Start Time	TUNNEL AVE Southbound				BLANKEN AVE Westbound				TUNNEL AVE Northbound				BLANKEN AVE Eastbound				Int. Total
	Right	Thru	Left	App. Total	Right	Thru	Left	App. Total	Right	Thru	Left	App. Total	Right	Thru	Left	App. Total	
04:45 PM	0	0	0	0	0	0	0	0	0	2	1	3	0	0	0	0	3
05:00 PM	0	0	0	0	0	0	0	0	0	0	1	1	1	0	0	1	2
05:15 PM	0	0	0	0	0	0	0	0	0	1	1	2	0	0	0	0	2
05:30 PM	0	0	0	0	0	0	0	0	0	4	0	4	1	0	0	1	5
Total Volume	0	0	0	0	0	0	0	0	0	7	3	10	2	0	0	2	12
% App. Total	0	0	0		0	0	0		0	70	30		100	0	0		
PHF	.000	.000	.000	.000	.000	.000	.000	.000	.000	.438	.750	.625	.500	.000	.000	.500	.600

Peak Hour Analysis From 04:00 PM to 05:45 PM - Peak 1 of 1

Peak Hour for Entire Intersection Begins at 04:45 PM

Traffic Data Service

Campbell, CA

(408) 377-2988

tdsbay@cs.com

File Name : 1PM FINAL

Site Code : 00000001

Start Date : 9/24/2013

Page No : 2

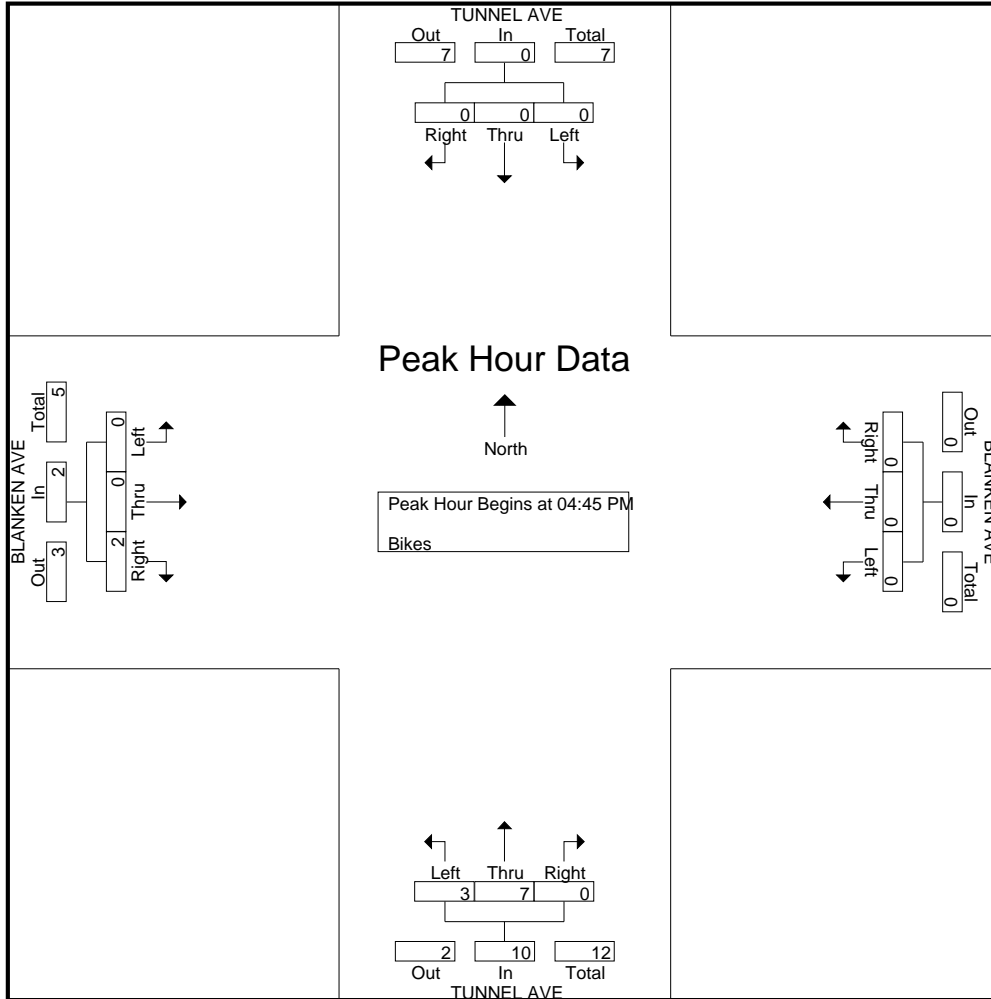

Traffic Data Service

Campbell, CA
(408) 377-2988
tdsbay@cs.com

File Name : 2AM FINAL
Site Code : 00000002
Start Date : 9/24/2013
Page No : 1

Groups Printed- Vehicles

Start Time	DW Southbound					S LINDEN AVE Westbound					DOLLAR AVE Northbound					S LINDEN AVE Eastbound					Int. Total
	Right	Thru	Left	Peds	App. Total	Right	Thru	Left	Peds	App. Total	Right	Thru	Left	Peds	App. Total	Right	Thru	Left	Peds	App. Total	
07:00 AM	1	0	3	1	5	1	18	9	0	28	10	0	13	2	25	12	25	0	0	37	95
07:15 AM	0	0	1	0	1	0	17	9	0	26	16	0	16	0	32	14	27	0	0	41	100
07:30 AM	0	0	1	2	3	0	31	15	0	46	9	0	15	0	24	25	45	0	0	70	143
07:45 AM	0	0	0	1	1	1	33	9	0	43	20	0	13	2	35	17	41	0	0	58	137
Total	1	0	5	4	10	2	99	42	0	143	55	0	57	4	116	68	138	0	0	206	475
08:00 AM	0	0	1	2	3	0	21	9	1	31	17	0	12	1	30	9	40	0	0	49	113
08:15 AM	0	0	0	0	0	0	32	6	0	38	12	0	24	1	37	16	32	0	1	49	124
08:30 AM	0	0	0	1	1	0	32	10	0	42	24	0	11	3	38	12	41	0	0	53	134
08:45 AM	0	0	0	1	1	0	24	9	0	33	11	0	30	0	41	12	46	0	0	58	133
Total	0	0	1	4	5	0	109	34	1	144	64	0	77	5	146	49	159	0	1	209	504
Grand Total	1	0	6	8	15	2	208	76	1	287	119	0	134	9	262	117	297	0	1	415	979
Apprch %	6.7	0	40	53.3		0.7	72.5	26.5	0.3		45.4	0	51.1	3.4		28.2	71.6	0	0.2		
Total %	0.1	0	0.6	0.8	1.5	0.2	21.2	7.8	0.1	29.3	12.2	0	13.7	0.9	26.8	12	30.3	0	0.1	42.4	

Start Time	DW Southbound				S LINDEN AVE Westbound				DOLLAR AVE Northbound				S LINDEN AVE Eastbound				Int. Total
	Right	Thru	Left	App. Total	Right	Thru	Left	App. Total	Right	Thru	Left	App. Total	Right	Thru	Left	App. Total	
Peak Hour Analysis From 07:00 AM to 08:45 AM - Peak 1 of 1																	
Peak Hour for Entire Intersection Begins at 07:30 AM																	
07:30 AM	0	0	1	1	0	31	15	46	9	0	15	24	25	45	0	70	141
07:45 AM	0	0	0	0	1	33	9	43	20	0	13	33	17	41	0	58	134
08:00 AM	0	0	1	1	0	21	9	30	17	0	12	29	9	40	0	49	109
08:15 AM	0	0	0	0	0	32	6	38	12	0	24	36	16	32	0	48	122
Total Volume	0	0	2	2	1	117	39	157	58	0	64	122	67	158	0	225	506
% App. Total	0	0	100		0.6	74.5	24.8		47.5	0	52.5		29.8	70.2	0		
PHF	.000	.000	.500	.500	.250	.886	.650	.853	.725	.000	.667	.847	.670	.878	.000	.804	.897

Traffic Data Service

Campbell, CA

(408) 377-2988

tdsbay@cs.com

File Name : 2AM FINAL

Site Code : 00000002

Start Date : 9/24/2013

Page No : 2

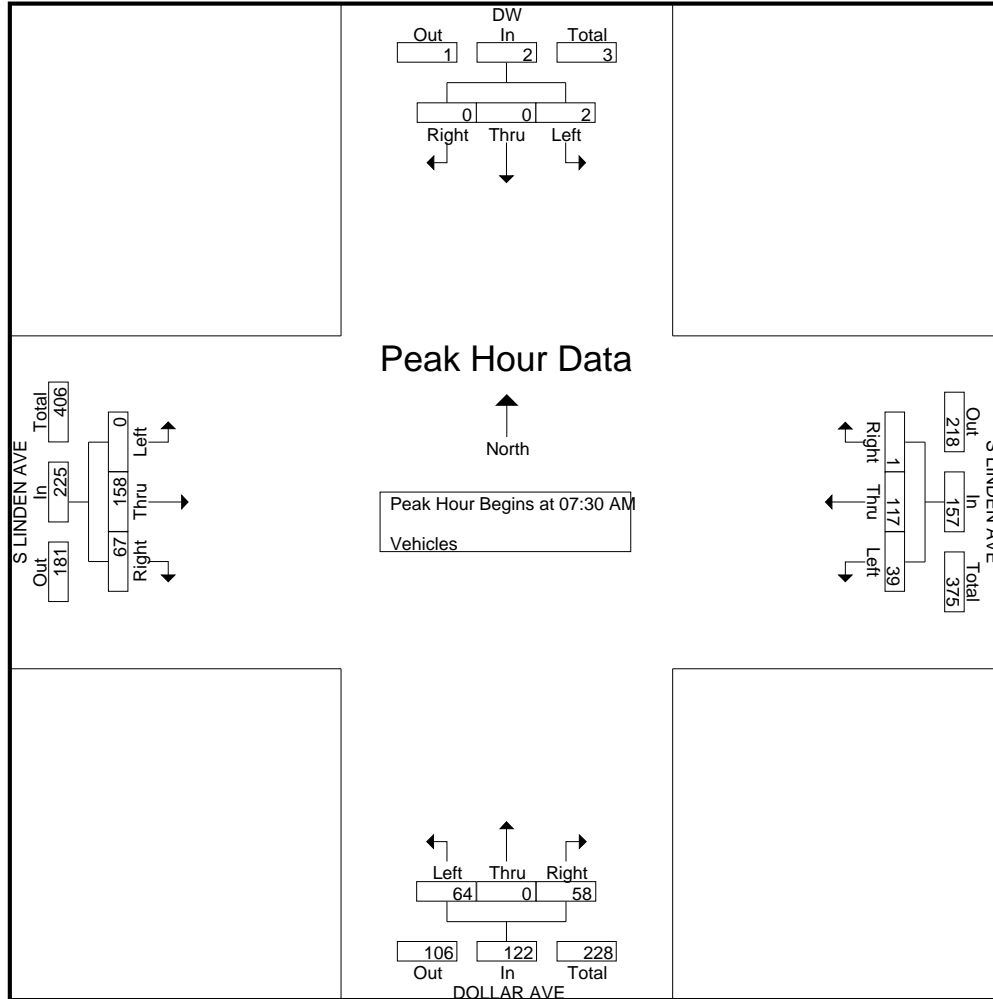

Traffic Data Service

Campbell, CA
 (408) 377-2988
 tdsbay@cs.com

File Name : 2AM FINAL
 Site Code : 00000002
 Start Date : 9/24/2013
 Page No : 1

Groups Printed- Bikes

Start Time	DW Southbound					S LINDEN AVE Westbound					DOLLAR AVE Northbound					S LINDEN AVE Eastbound					Int. Total
	Right	Thru	Left	Peds	App. Total	Right	Thru	Left	Peds	App. Total	Right	Thru	Left	Peds	App. Total	Right	Thru	Left	Peds	App. Total	
07:00 AM	0	0	0	0	0	0	0	0	0	0	0	0	0	0	0	0	1	0	0	1	1
07:15 AM	0	0	0	0	0	0	0	0	0	0	0	0	0	0	0	1	1	0	0	2	2
07:30 AM	0	0	0	0	0	0	0	0	0	0	2	0	0	0	2	1	0	0	0	1	3
07:45 AM	0	0	0	0	0	0	0	0	0	0	1	0	1	0	2	0	0	0	0	0	2
Total	0	0	0	0	0	0	0	0	0	0	3	0	1	0	4	2	2	0	0	4	8
08:00 AM	0	0	0	0	0	0	0	0	0	0	0	1	0	0	1	0	0	0	0	0	1
08:15 AM	0	0	0	0	0	0	0	0	0	0	0	0	0	0	0	0	0	0	0	0	0
08:30 AM	0	0	0	0	0	0	1	0	0	1	0	0	0	0	0	0	0	0	0	0	1
08:45 AM	0	0	0	0	0	0	0	0	0	0	0	0	1	0	1	0	0	0	0	0	1
Total	0	0	0	0	0	0	1	0	0	1	0	1	1	0	2	0	0	0	0	0	3
Grand Total	0	0	0	0	0	0	1	0	0	1	3	1	2	0	6	2	2	0	0	4	11
Apprch %	0	0	0	0	0	0	100	0	0		50	16.7	33.3	0		50	50	0	0		
Total %	0	0	0	0	0	0	9.1	0	0	9.1	27.3	9.1	18.2	0	54.5	18.2	18.2	0	0	36.4	

Start Time	DW Southbound				S LINDEN AVE Westbound				DOLLAR AVE Northbound				S LINDEN AVE Eastbound				Int. Total
	Right	Thru	Left	App. Total	Right	Thru	Left	App. Total	Right	Thru	Left	App. Total	Right	Thru	Left	App. Total	
07:00 AM	0	0	0	0	0	0	0	0	0	0	0	0	0	1	0	1	1
07:15 AM	0	0	0	0	0	0	0	0	0	0	0	0	1	1	0	2	2
07:30 AM	0	0	0	0	0	0	0	0	2	0	0	2	1	0	0	1	3
07:45 AM	0	0	0	0	0	0	0	0	1	0	1	2	0	0	0	0	2
Total Volume	0	0	0	0	0	0	0	0	3	0	1	4	2	2	0	4	8
% App. Total	0	0	0	0	0	0	0	0	75	0	25		50	50	0		
PHF	.000	.000	.000	.000	.000	.000	.000	.000	.375	.000	.250	.500	.500	.500	.000	.500	.667

Peak Hour Analysis From 07:00 AM to 08:45 AM - Peak 1 of 1

Peak Hour for Entire Intersection Begins at 07:00 AM

Traffic Data Service

Campbell, CA

(408) 377-2988

tdsbay@cs.com

File Name : 2AM FINAL

Site Code : 00000002

Start Date : 9/24/2013

Page No : 2

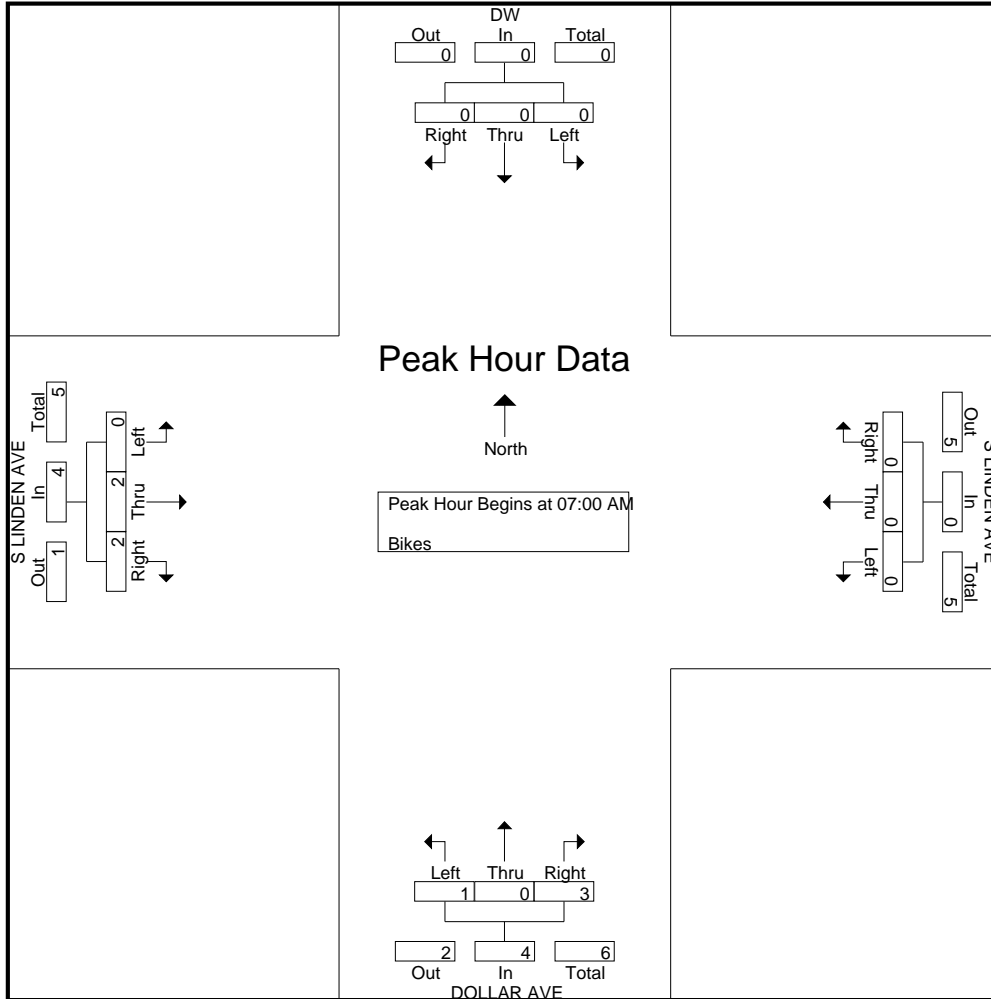

Traffic Data Service

Campbell, CA
 (408) 377-2988
 tdsbay@cs.com

File Name : 2PM FINAL
 Site Code : 00000002
 Start Date : 9/24/2013
 Page No : 1

Groups Printed- Vehicles

Start Time	DW Southbound					S LINDEN AVE Westbound					DOLLAR AVE Northbound					S LINDEN AVE Eastbound					Int. Total
	Right	Thru	Left	Peds	App. Total	Right	Thru	Left	Peds	App. Total	Right	Thru	Left	Peds	App. Total	Right	Thru	Left	Peds	App. Total	
04:00 PM	0	0	0	5	5	0	35	8	0	43	15	0	19	1	35	27	59	0	0	86	169
04:15 PM	0	0	0	0	0	0	39	12	0	51	8	0	29	0	37	33	44	0	0	77	165
04:30 PM	0	0	0	0	0	0	65	14	0	79	9	0	27	2	38	34	64	0	0	98	215
04:45 PM	0	0	0	0	0	0	67	11	0	78	15	0	12	1	28	23	60	0	0	83	189
Total	0	0	0	5	5	0	206	45	0	251	47	0	87	4	138	117	227	0	0	344	738
05:00 PM	0	0	0	0	0	0	63	9	0	72	11	0	12	4	27	25	44	0	0	69	168
05:15 PM	0	0	0	1	1	0	47	6	0	53	14	0	18	3	35	22	41	0	0	63	152
05:30 PM	0	0	0	0	0	0	58	10	0	68	13	0	21	0	34	29	35	0	0	64	166
05:45 PM	0	0	0	1	1	0	55	13	0	68	5	0	19	0	24	30	40	0	0	70	163
Total	0	0	0	2	2	0	223	38	0	261	43	0	70	7	120	106	160	0	0	266	649
Grand Total	0	0	0	7	7	0	429	83	0	512	90	0	157	11	258	223	387	0	0	610	1387
Apprch %	0	0	0	100		0	83.8	16.2	0		34.9	0	60.9	4.3		36.6	63.4	0	0		
Total %	0	0	0	0.5	0.5	0	30.9	6	0	36.9	6.5	0	11.3	0.8	18.6	16.1	27.9	0	0	44	

Start Time	DW Southbound				S LINDEN AVE Westbound				DOLLAR AVE Northbound				S LINDEN AVE Eastbound				Int. Total
	Right	Thru	Left	App. Total	Right	Thru	Left	App. Total	Right	Thru	Left	App. Total	Right	Thru	Left	App. Total	
Peak Hour Analysis From 04:00 PM to 05:45 PM - Peak 1 of 1																	
Peak Hour for Entire Intersection Begins at 04:15 PM																	
04:15 PM	0	0	0	0	0	39	12	51	8	0	29	37	33	44	0	77	165
04:30 PM	0	0	0	0	0	65	14	79	9	0	27	36	34	64	0	98	213
04:45 PM	0	0	0	0	0	67	11	78	15	0	12	27	23	60	0	83	188
05:00 PM	0	0	0	0	0	63	9	72	11	0	12	23	25	44	0	69	164
Total Volume	0	0	0	0	0	234	46	280	43	0	80	123	115	212	0	327	730
% App. Total	0	0	0		0	83.6	16.4		35	0	65		35.2	64.8	0		
PHF	.000	.000	.000	.000	.000	.873	.821	.886	.717	.000	.690	.831	.846	.828	.000	.834	.857

Traffic Data Service

Campbell, CA
 (408) 377-2988
 tdsbay@cs.com

File Name : 2PM FINAL
 Site Code : 00000002
 Start Date : 9/24/2013
 Page No : 2

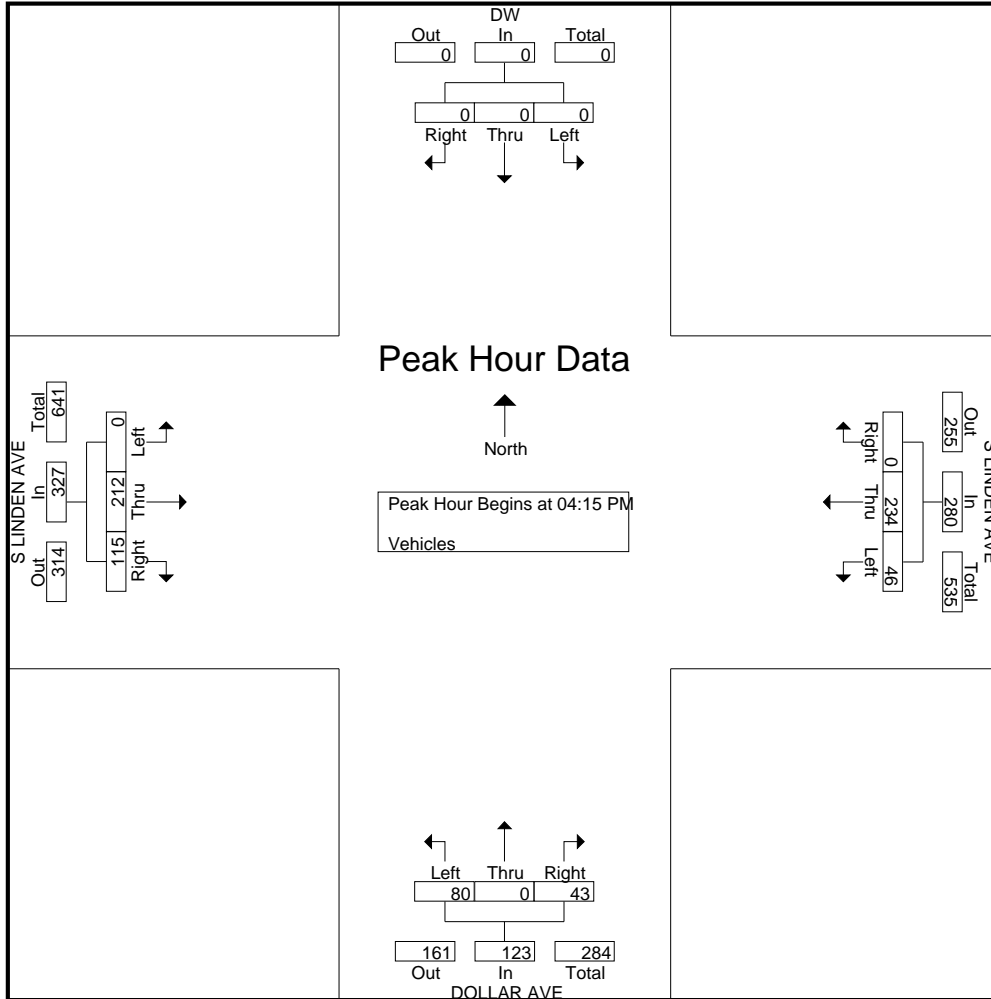

Traffic Data Service

Campbell, CA
 (408) 377-2988
 tdsbay@cs.com

File Name : 2PM FINAL
 Site Code : 00000002
 Start Date : 9/24/2013
 Page No : 1

Groups Printed- Bikes

Start Time	DW Southbound					S LINDEN AVE Westbound					DOLLAR AVE Northbound					S LINDEN AVE Eastbound					Int. Total
	Right	Thru	Left	Peds	App. Total	Right	Thru	Left	Peds	App. Total	Right	Thru	Left	Peds	App. Total	Right	Thru	Left	Peds	App. Total	
04:00 PM	0	0	0	0	0	0	0	1	0	1	0	0	0	0	0	1	0	0	0	1	2
04:15 PM	0	0	0	0	0	0	0	0	0	0	0	0	1	0	1	0	0	0	0	0	1
04:30 PM	0	1	0	0	1	0	0	1	0	1	0	0	0	0	0	1	0	0	0	1	3
04:45 PM	0	0	0	0	0	0	0	1	0	1	0	0	0	0	0	1	1	0	0	2	3
Total	0	1	0	0	1	0	0	3	0	3	0	0	1	0	1	3	1	0	0	4	9
05:00 PM	0	0	0	0	0	0	0	5	0	5	0	0	0	0	0	0	1	0	0	1	6
05:15 PM	0	0	0	0	0	0	0	1	0	1	0	0	0	0	0	0	1	0	0	1	2
05:30 PM	0	0	0	0	0	0	0	1	0	1	0	0	0	0	0	1	0	0	0	1	2
05:45 PM	0	0	0	0	0	0	0	0	0	0	0	0	0	0	0	0	0	0	0	0	0
Total	0	0	0	0	0	0	0	7	0	7	0	0	0	0	0	1	2	0	0	3	10
Grand Total	0	1	0	0	1	0	0	10	0	10	0	0	1	0	1	4	3	0	0	7	19
Apprch %	0	100	0	0		0	0	100	0		0	0	100	0		57.1	42.9	0	0		
Total %	0	5.3	0	0	5.3	0	0	52.6	0	52.6	0	0	5.3	0	5.3	21.1	15.8	0	0	36.8	

Start Time	DW Southbound				S LINDEN AVE Westbound				DOLLAR AVE Northbound				S LINDEN AVE Eastbound				Int. Total
	Right	Thru	Left	App. Total	Right	Thru	Left	App. Total	Right	Thru	Left	App. Total	Right	Thru	Left	App. Total	
04:30 PM	0	1	0	1	0	0	1	1	0	0	0	0	1	0	0	1	3
04:45 PM	0	0	0	0	0	0	1	1	0	0	0	0	1	1	0	2	3
05:00 PM	0	0	0	0	0	0	5	5	0	0	0	0	0	1	0	1	6
05:15 PM	0	0	0	0	0	0	1	1	0	0	0	0	0	1	0	1	2
Total Volume	0	1	0	1	0	0	8	8	0	0	0	0	2	3	0	5	14
% App. Total	0	100	0		0	0	100		0	0	0		40	60	0		
PHF	.000	.250	.000	.250	.000	.000	.400	.400	.000	.000	.000	.000	.500	.750	.000	.625	.583

Peak Hour Analysis From 04:00 PM to 05:45 PM - Peak 1 of 1

Peak Hour for Entire Intersection Begins at 04:30 PM

Traffic Data Service

Campbell, CA

(408) 377-2988

tdsbay@cs.com

File Name : 2PM FINAL

Site Code : 00000002

Start Date : 9/24/2013

Page No : 2

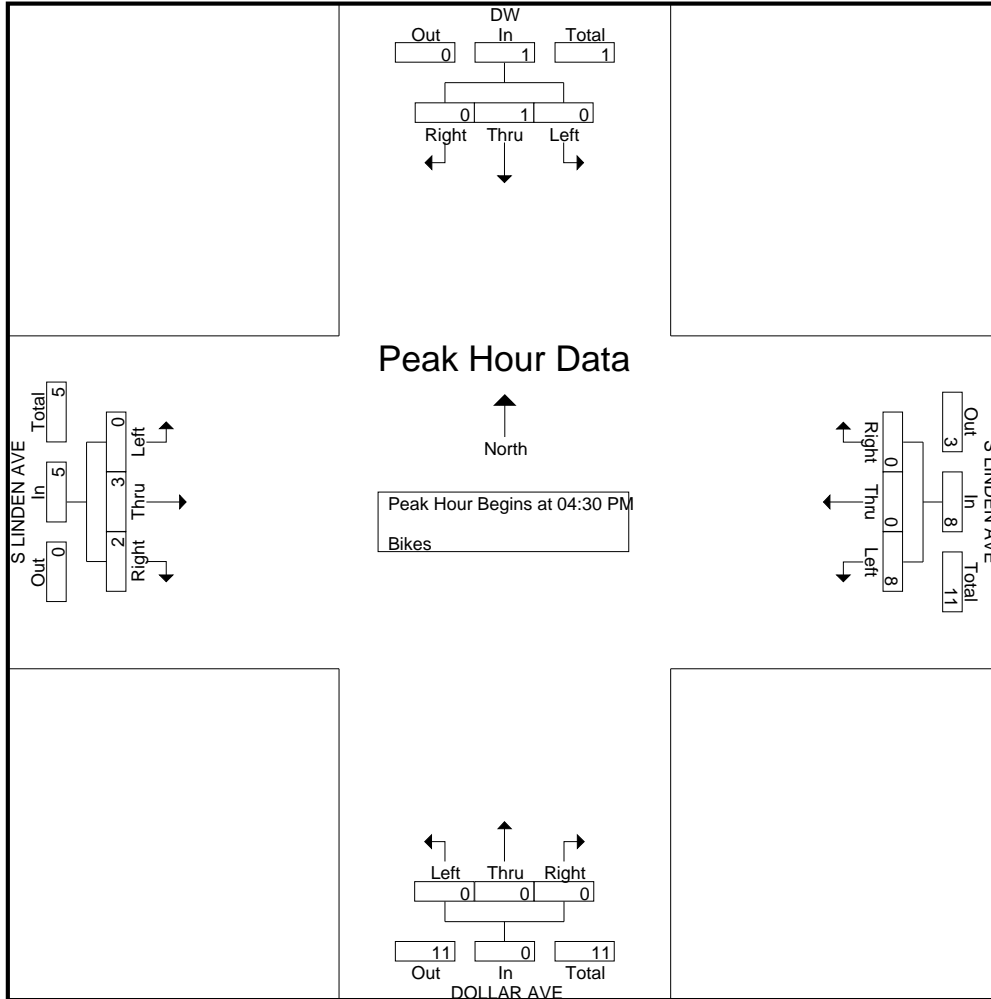

Traffic Data Service

Campbell, CA
 (408) 377-2988
 tdsbay@cs.com

File Name : 8AM FINAL
 Site Code : 00000008
 Start Date : 6/6/2013
 Page No : 1

Groups Printed- Vehicles

Start Time	DUBUQUE AVE Southbound					E. GRAND AVE Westbound					Northbound					E. GRAND AVE Eastbound					Int. Total
	Right	Thru	Left	Peds	App. Total	Right	Thru	Left	Peds	App. Total	Right	Thru	Left	Peds	App. Total	Right	Thru	Left	Peds	App. Total	
07:00 AM	8	0	4	0	12	6	55	0	10	71	0	0	0	0	0	0	102	9	0	111	194
07:15 AM	2	0	0	0	2	7	98	0	12	117	0	0	0	0	0	0	126	8	0	134	253
07:30 AM	8	0	5	0	13	11	130	0	4	145	0	0	0	0	0	0	145	8	0	153	311
07:45 AM	2	0	3	2	7	9	117	0	5	131	0	0	0	0	0	0	188	7	0	195	333
Total	20	0	12	2	34	33	400	0	31	464	0	0	0	0	0	0	561	32	0	593	1091
08:00 AM	9	0	6	0	15	5	109	0	9	123	0	0	0	0	0	0	166	13	0	179	317
08:15 AM	10	0	4	0	14	7	114	0	11	132	0	0	0	0	0	0	153	6	0	159	305
08:30 AM	11	0	10	0	21	11	124	0	14	149	0	0	0	0	0	0	176	13	0	189	359
08:45 AM	12	0	6	0	18	12	177	0	1	190	0	0	0	0	0	0	152	7	0	159	367
Total	42	0	26	0	68	35	524	0	35	594	0	0	0	0	0	0	647	39	0	686	1348
Grand Total	62	0	38	2	102	68	924	0	66	1058	0	0	0	0	0	0	1208	71	0	1279	2439
Apprch %	60.8	0	37.3	2		6.4	87.3	0	6.2		0	0	0	0	0	0	94.4	5.6	0		
Total %	2.5	0	1.6	0.1	4.2	2.8	37.9	0	2.7	43.4	0	0	0	0	0	0	49.5	2.9	0	52.4	

Start Time	DUBUQUE AVE Southbound				E. GRAND AVE Westbound				Northbound				E. GRAND AVE Eastbound				Int. Total	
	Right	Thru	Left	App. Total	Right	Thru	Left	App. Total	Right	Thru	Left	App. Total	Right	Thru	Left	App. Total		
Peak Hour Analysis From 07:00 AM to 08:45 AM - Peak 1 of 1																		
Peak Hour for Entire Intersection Begins at 08:00 AM																		
08:00 AM	9	0	6	15	5	109	0	114	0	0	0	0	0	0	166	13	179	308
08:15 AM	10	0	4	14	7	114	0	121	0	0	0	0	0	0	153	6	159	294
08:30 AM	11	0	10	21	11	124	0	135	0	0	0	0	0	0	176	13	189	345
08:45 AM	12	0	6	18	12	177	0	189	0	0	0	0	0	0	152	7	159	366
Total Volume	42	0	26	68	35	524	0	559	0	0	0	0	0	0	647	39	686	1313
% App. Total	61.8	0	38.2		6.3	93.7	0		0	0	0		0	94.3	5.7			
PHF	.875	.000	.650	.810	.729	.740	.000	.739	.000	.000	.000	.000	.000	.000	.919	.750	.907	.897

Traffic Data Service

Campbell, CA

(408) 377-2988

tdsbay@cs.com

File Name : 8AM FINAL

Site Code : 00000008

Start Date : 6/6/2013

Page No : 2

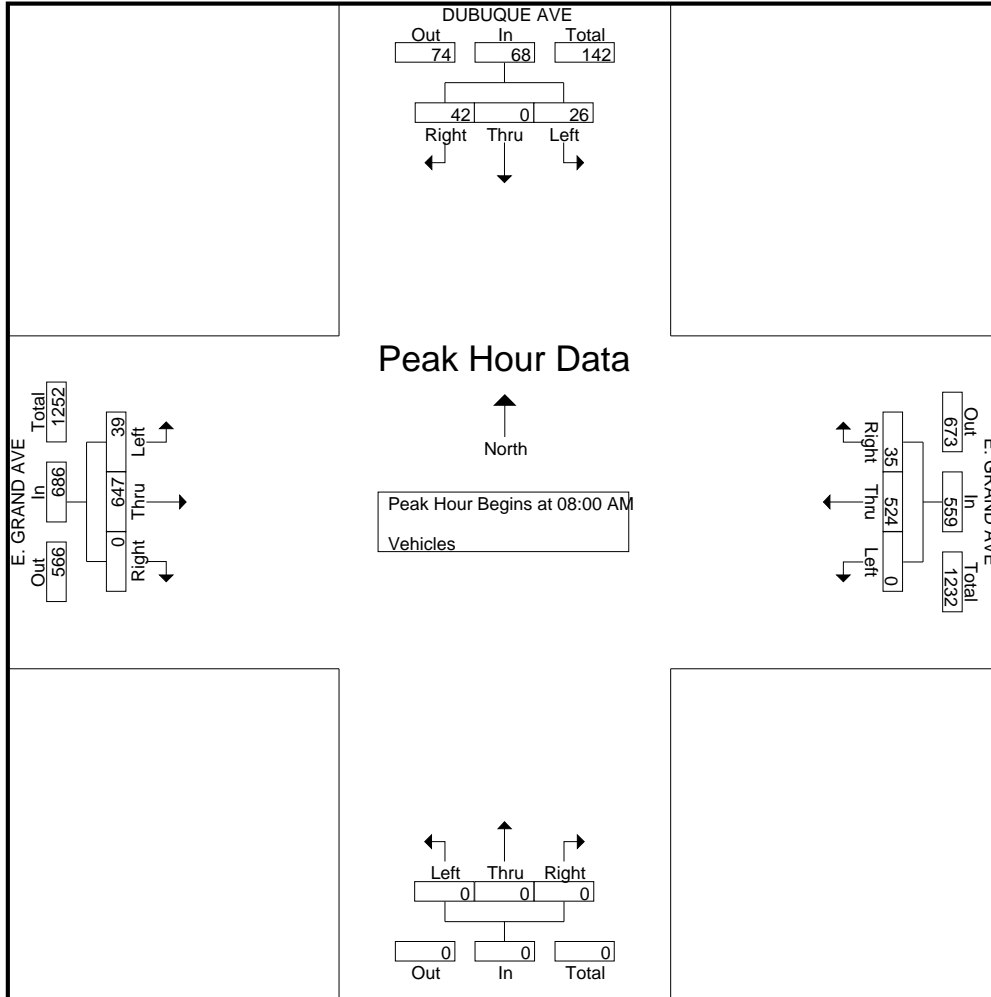

Traffic Data Service

Campbell, CA
 (408) 377-2988
 tdsbay@cs.com

File Name : 8AM FINAL
 Site Code : 00000008
 Start Date : 6/6/2013
 Page No : 1

Groups Printed- Bikes

Start Time	DUBUQUE AVE Southbound					E. GRAND AVE Westbound					Northbound					E. GRAND AVE Eastbound					Int. Total
	Right	Thru	Left	Peds	App. Total	Right	Thru	Left	Peds	App. Total	Right	Thru	Left	Peds	App. Total	Right	Thru	Left	Peds	App. Total	
07:00 AM	0	0	0	0	0	0	0	0	0	0	0	0	0	0	0	0	0	0	0	0	0
07:15 AM	1	0	0	0	1	0	1	0	0	1	0	0	0	0	0	0	0	0	0	0	0
07:30 AM	1	0	0	0	1	0	0	0	0	0	0	0	0	0	0	0	0	1	0	1	2
07:45 AM	0	0	0	0	0	0	0	0	0	0	0	0	0	0	0	0	0	0	0	0	0
Total	2	0	0	0	2	0	1	0	0	1	0	0	0	0	0	0	0	1	0	1	4
08:00 AM	0	0	0	0	0	0	0	0	0	0	0	0	0	0	0	0	0	0	0	0	0
08:15 AM	0	0	0	0	0	0	0	0	0	0	0	0	0	0	0	0	0	0	0	0	0
08:30 AM	0	0	0	0	0	0	0	0	0	0	0	0	0	0	0	0	0	0	0	0	0
08:45 AM	0	0	0	0	0	0	0	0	0	0	0	0	0	0	0	0	1	0	0	1	1
Total	0	0	0	0	0	0	0	0	0	0	0	0	0	0	0	0	1	0	0	1	1
Grand Total	2	0	0	0	2	0	1	0	0	1	0	0	0	0	0	0	1	1	0	2	5
Apprch %	100	0	0	0		0	100	0	0		0	0	0	0		0	50	50	0		
Total %	40	0	0	0	40	0	20	0	0	20	0	0	0	0	0	0	20	20	0	40	

Start Time	DUBUQUE AVE Southbound				E. GRAND AVE Westbound				Northbound				E. GRAND AVE Eastbound				Int. Total
	Right	Thru	Left	App. Total	Right	Thru	Left	App. Total	Right	Thru	Left	App. Total	Right	Thru	Left	App. Total	
07:00 AM	0	0	0	0	0	0	0	0	0	0	0	0	0	0	0	0	0
07:15 AM	1	0	0	1	0	1	0	1	0	0	0	0	0	0	0	0	2
07:30 AM	1	0	0	1	0	0	0	0	0	0	0	0	0	0	1	1	2
07:45 AM	0	0	0	0	0	0	0	0	0	0	0	0	0	0	0	0	0
Total Volume	2	0	0	2	0	1	0	1	0	0	0	0	0	0	1	1	4
% App. Total	100	0	0		0	100	0		0	0	0		0	0	100		
PHF	.500	.000	.000	.500	.000	.250	.000	.250	.000	.000	.000	.000	.000	.000	.250	.250	.500

Peak Hour Analysis From 07:00 AM to 08:45 AM - Peak 1 of 1

Peak Hour for Entire Intersection Begins at 07:00 AM

Traffic Data Service

Campbell, CA

(408) 377-2988

tdsbay@cs.com

File Name : 8AM FINAL

Site Code : 00000008

Start Date : 6/6/2013

Page No : 2

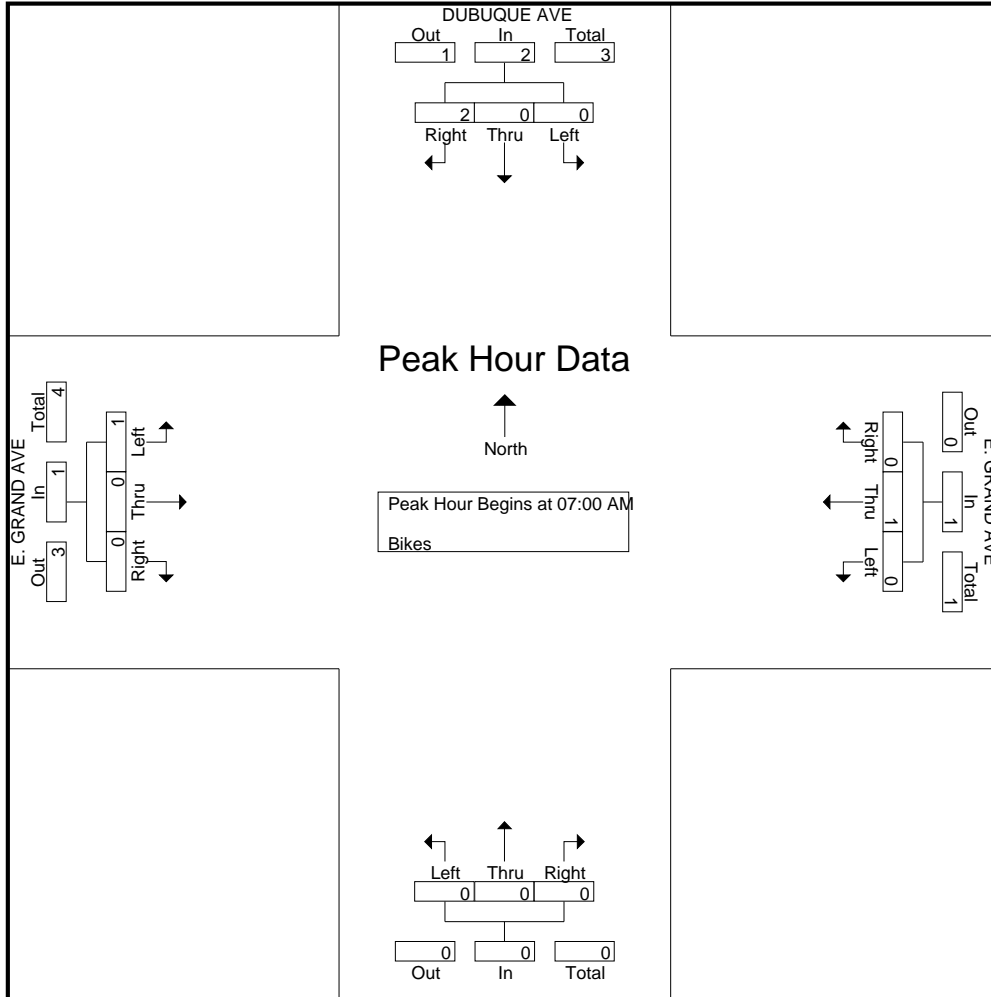

Traffic Data Service

Campbell, CA
 (408) 377-2988
 tdsbay@cs.com

File Name : 8PM FINAL
 Site Code : 00000008
 Start Date : 6/6/2013
 Page No : 1

Groups Printed- Vehicles

Start Time	DUBUQUE AVE Southbound					E. GRAND AVE Westbound					Northbound					E. GRAND AVE Eastbound					Int. Total
	Right	Thru	Left	Peds	App. Total	Right	Thru	Left	Peds	App. Total	Right	Thru	Left	Peds	App. Total	Right	Thru	Left	Peds	App. Total	
04:00 PM	10	0	6	0	16	9	355	0	6	370	0	0	0	0	0	0	55	14	0	69	455
04:15 PM	13	0	4	0	17	20	324	0	12	356	0	0	0	0	0	0	38	11	0	49	422
04:30 PM	10	0	4	2	16	21	329	0	4	354	0	0	0	0	0	0	54	13	0	67	437
04:45 PM	20	0	4	0	24	17	389	0	6	412	0	0	0	0	0	0	65	6	0	71	507
Total	53	0	18	2	73	67	1397	0	28	1492	0	0	0	0	0	0	212	44	0	256	1821
05:00 PM	12	0	2	0	14	14	402	0	12	428	0	0	0	0	0	0	55	6	0	61	503
05:15 PM	9	0	3	0	12	8	410	0	3	421	0	0	0	0	0	0	53	3	0	56	489
05:30 PM	6	0	3	0	9	17	365	0	6	388	0	0	0	0	0	0	56	8	0	64	461
05:45 PM	15	0	4	0	19	13	298	0	4	315	0	0	0	0	0	0	77	8	0	85	419
Total	42	0	12	0	54	52	1475	0	25	1552	0	0	0	0	0	0	241	25	0	266	1872
Grand Total	95	0	30	2	127	119	2872	0	53	3044	0	0	0	0	0	0	453	69	0	522	3693
Apprch %	74.8	0	23.6	1.6		3.9	94.3	0	1.7		0	0	0	0	0	0	86.8	13.2	0		
Total %	2.6	0	0.8	0.1	3.4	3.2	77.8	0	1.4	82.4	0	0	0	0	0	0	12.3	1.9	0	14.1	

Start Time	DUBUQUE AVE Southbound					E. GRAND AVE Westbound					Northbound					E. GRAND AVE Eastbound					Int. Total
	Right	Thru	Left	Peds	App. Total	Right	Thru	Left	Peds	App. Total	Right	Thru	Left	Peds	App. Total	Right	Thru	Left	Peds	App. Total	
Peak Hour Analysis From 04:00 PM to 05:45 PM - Peak 1 of 1																					
Peak Hour for Entire Intersection Begins at 04:45 PM																					
04:45 PM	20	0	4	0	24	17	389	0	6	406	0	0	0	0	0	0	65	6	0	71	501
05:00 PM	12	0	2	0	14	14	402	0	12	416	0	0	0	0	0	0	55	6	0	61	491
05:15 PM	9	0	3	0	12	8	410	0	3	418	0	0	0	0	0	0	53	3	0	56	486
05:30 PM	6	0	3	0	9	17	365	0	6	382	0	0	0	0	0	0	56	8	0	64	455
Total Volume	47	0	12	0	59	56	1566	0	16	1622	0	0	0	0	0	0	229	23	0	252	1933
% App. Total	79.7	0	20.3	0		3.5	96.5	0	1.4		0	0	0	0	0	0	90.9	9.1	0		
PHF	.588	.000	.750	.000	.615	.824	.955	.000	.970		.000	.000	.000	.000	.000	.000	.881	.719	.000	.887	.965

Traffic Data Service

Campbell, CA

(408) 377-2988

tdsbay@cs.com

File Name : 8PM FINAL

Site Code : 00000008

Start Date : 6/6/2013

Page No : 2

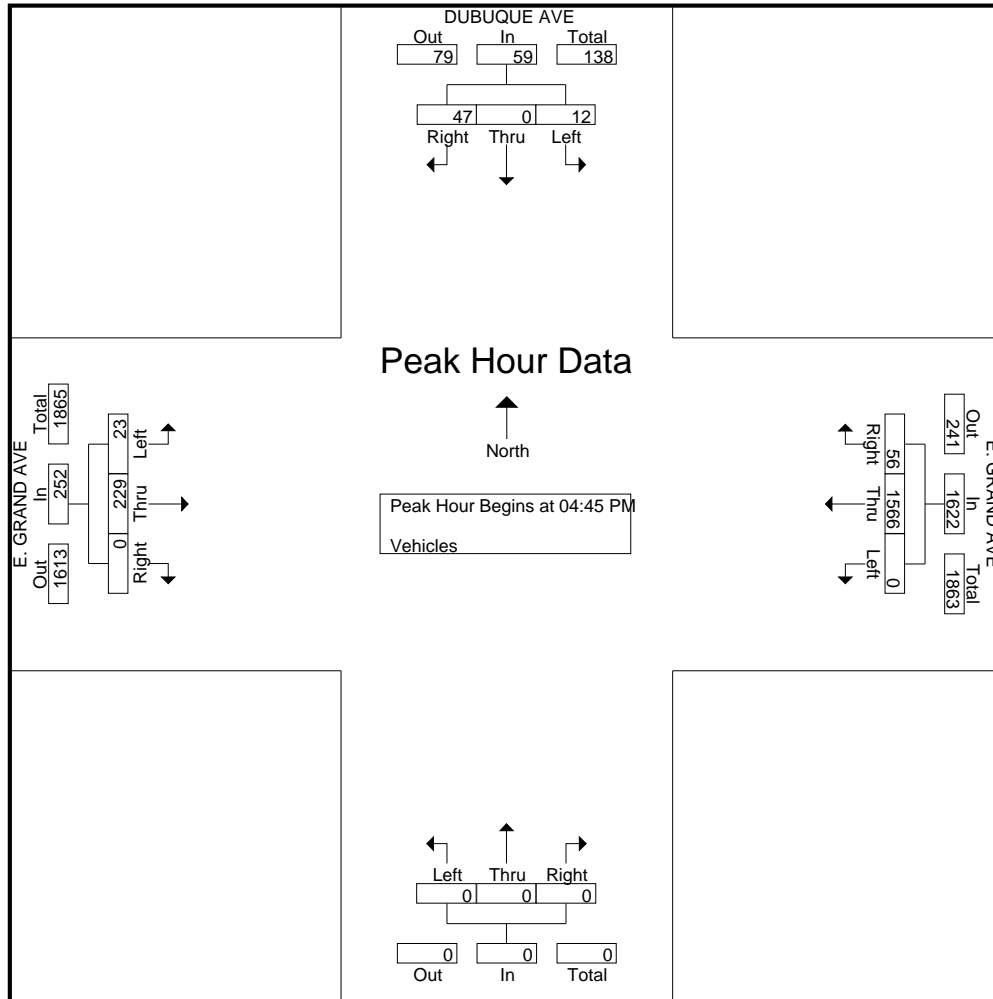

Traffic Data Service

Campbell, CA
 (408) 377-2988
 tdsbay@cs.com

File Name : 8PM FINAL
 Site Code : 00000008
 Start Date : 6/6/2013
 Page No : 1

Groups Printed- Bikes

Start Time	DUBUQUE AVE Southbound					E. GRAND AVE Westbound					Northbound					E. GRAND AVE Eastbound					Int. Total
	Right	Thru	Left	Peds	App. Total	Right	Thru	Left	Peds	App. Total	Right	Thru	Left	Peds	App. Total	Right	Thru	Left	Peds	App. Total	
04:00 PM	0	0	0	0	0	0	0	0	0	0	0	0	0	0	0	0	0	0	0	0	0
04:15 PM	0	0	0	0	0	0	0	0	0	0	0	0	0	0	0	0	0	0	0	0	0
04:30 PM	0	0	0	0	0	0	1	0	0	1	0	0	0	0	0	0	0	0	0	0	1
04:45 PM	1	0	0	0	1	1	0	0	0	1	0	0	0	0	0	0	1	0	0	1	3
Total	1	0	0	0	1	1	1	0	0	2	0	0	0	0	0	0	1	0	0	1	4
05:00 PM	0	0	0	0	0	0	1	0	0	1	0	0	0	0	0	0	0	0	0	0	1
05:15 PM	0	0	0	0	0	0	0	0	0	0	0	0	0	0	0	0	0	0	0	0	0
05:30 PM	0	0	0	0	0	1	3	0	0	4	0	0	0	0	0	0	0	0	0	0	4
05:45 PM	0	0	0	0	0	0	0	0	0	0	0	0	0	0	0	0	0	0	0	0	0
Total	0	0	0	0	0	1	4	0	0	5	0	0	0	0	0	0	0	0	0	0	5
Grand Total	1	0	0	0	1	2	5	0	0	7	0	0	0	0	0	0	1	0	0	1	9
Apprch %	100	0	0	0		28.6	71.4	0	0		0	0	0	0		0	100	0	0		
Total %	11.1	0	0	0	11.1	22.2	55.6	0	0	77.8	0	0	0	0	0	0	11.1	0	0	11.1	

Start Time	DUBUQUE AVE Southbound				E. GRAND AVE Westbound				Northbound				E. GRAND AVE Eastbound				Int. Total
	Right	Thru	Left	App. Total	Right	Thru	Left	App. Total	Right	Thru	Left	App. Total	Right	Thru	Left	App. Total	
Peak Hour Analysis From 04:00 PM to 05:45 PM - Peak 1 of 1																	
Peak Hour for Entire Intersection Begins at 04:45 PM																	
04:45 PM	1	0	0	1	1	0	0	1	0	0	0	0	0	1	0	1	3
05:00 PM	0	0	0	0	0	1	0	1	0	0	0	0	0	0	0	0	1
05:15 PM	0	0	0	0	0	0	0	0	0	0	0	0	0	0	0	0	0
05:30 PM	0	0	0	0	1	3	0	4	0	0	0	0	0	0	0	0	4
Total Volume	1	0	0	1	2	4	0	6	0	0	0	0	0	1	0	1	8
% App. Total	100	0	0		33.3	66.7	0		0	0	0		0	100	0		
PHF	.250	.000	.000	.250	.500	.333	.000	.375	.000	.000	.000	.000	.000	.250	.000	.250	.500

Traffic Data Service

Campbell, CA

(408) 377-2988

tdsbay@cs.com

File Name : 8PM FINAL

Site Code : 00000008

Start Date : 6/6/2013

Page No : 2

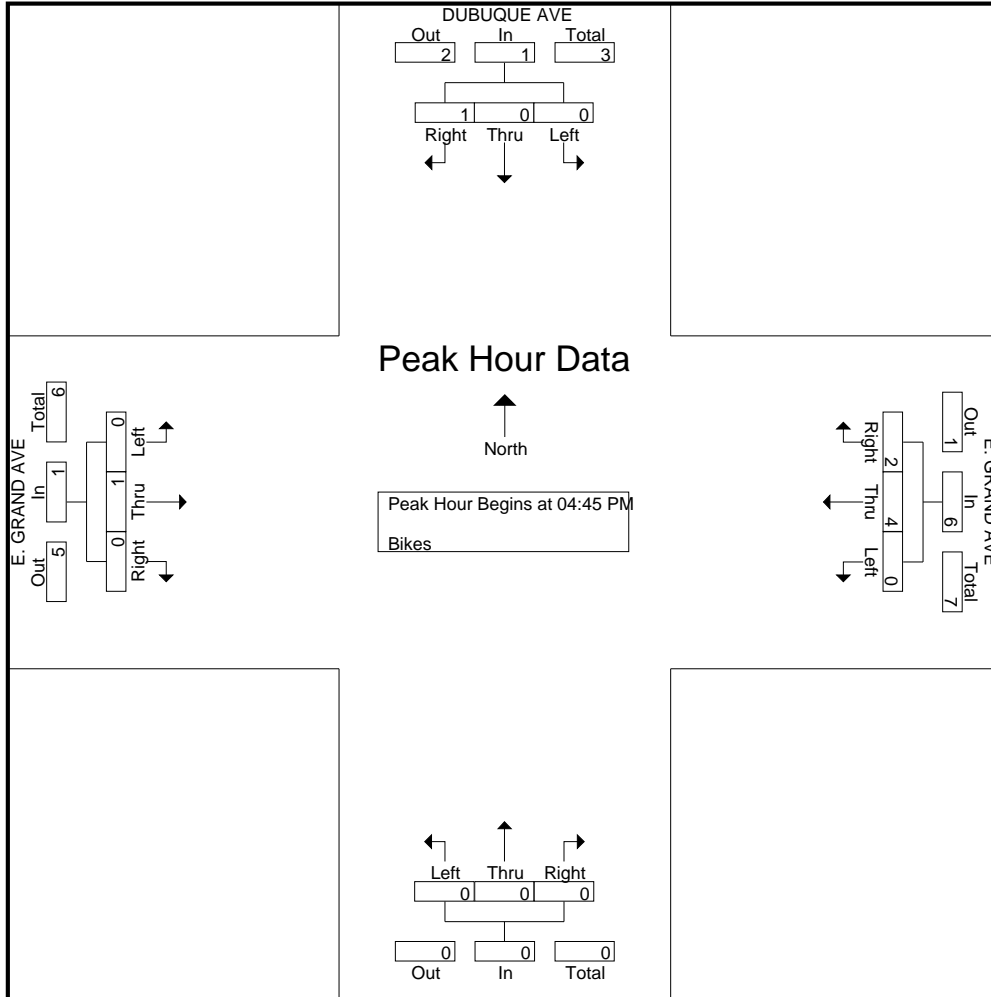

Traffic Data Service

Campbell, CA
 (408) 377-2988
 tdsbay@cs.com

File Name : 9AM FINAL
 Site Code : 00000009
 Start Date : 6/6/2013
 Page No : 1

Groups Printed- Vehicles

Start Time	SAN MATEO AVE Southbound					SAN MATEO AVE Westbound					SAN MATEO AVE Northbound					S. LINDEN AVE Eastbound					Int. Total
	Right	Thru	Left	Peds	App. Total	Right	Thru	Left	Peds	App. Total	Right	Thru	Left	Peds	App. Total	Right	Thru	Left	Peds	App. Total	
07:00 AM	20	33	0	0	53	0	0	0	0	0	0	33	15	0	48	14	0	30	0	44	145
07:15 AM	28	20	0	0	48	0	0	0	0	0	0	42	13	0	55	15	0	32	0	47	150
07:30 AM	17	43	0	0	60	0	0	0	0	0	0	49	10	2	61	29	0	36	0	65	186
07:45 AM	21	44	0	2	67	0	0	0	0	0	0	52	18	1	71	24	0	37	3	64	202
Total	86	140	0	2	228	0	0	0	0	0	0	176	56	3	235	82	0	135	3	220	683
08:00 AM	22	44	0	1	67	0	0	0	0	0	0	52	26	0	78	23	0	23	1	47	192
08:15 AM	22	32	0	2	56	0	0	0	0	0	0	43	20	0	63	24	0	28	0	52	171
08:30 AM	21	37	0	2	60	0	0	0	0	0	0	50	23	0	73	27	0	25	0	52	185
08:45 AM	25	41	0	1	67	0	0	0	0	0	0	49	29	0	78	29	0	20	3	52	197
Total	90	154	0	6	250	0	0	0	0	0	0	194	98	0	292	103	0	96	4	203	745
Grand Total	176	294	0	8	478	0	0	0	0	0	0	370	154	3	527	185	0	231	7	423	1428
Apprch %	36.8	61.5	0	1.7		0	0	0	0	0	0	70.2	29.2	0.6		43.7	0	54.6	1.7		
Total %	12.3	20.6	0	0.6	33.5	0	0	0	0	0	0	25.9	10.8	0.2	36.9	13	0	16.2	0.5	29.6	

Start Time	SAN MATEO AVE Southbound				SAN MATEO AVE Westbound				SAN MATEO AVE Northbound				S. LINDEN AVE Eastbound				Int. Total
	Right	Thru	Left	App. Total	Right	Thru	Left	App. Total	Right	Thru	Left	App. Total	Right	Thru	Left	App. Total	
07:30 AM	17	43	0	60	0	0	0	0	0	49	10	59	29	0	36	65	184
07:45 AM	21	44	0	65	0	0	0	0	0	52	18	70	24	0	37	61	196
08:00 AM	22	44	0	66	0	0	0	0	0	52	26	78	23	0	23	46	190
08:15 AM	22	32	0	54	0	0	0	0	0	43	20	63	24	0	28	52	169
Total Volume	82	163	0	245	0	0	0	0	0	196	74	270	100	0	124	224	739
% App. Total	33.5	66.5	0		0	0	0		0	72.6	27.4		44.6	0	55.4		
PHF	.932	.926	.000	.928	.000	.000	.000	.000	.000	.942	.712	.865	.862	.000	.838	.862	.943

Peak Hour Analysis From 07:00 AM to 08:45 AM - Peak 1 of 1

Peak Hour for Entire Intersection Begins at 07:30 AM

Traffic Data Service

Campbell, CA
 (408) 377-2988
 tdsbay@cs.com

File Name : 9AM FINAL
 Site Code : 00000009
 Start Date : 6/6/2013
 Page No : 2

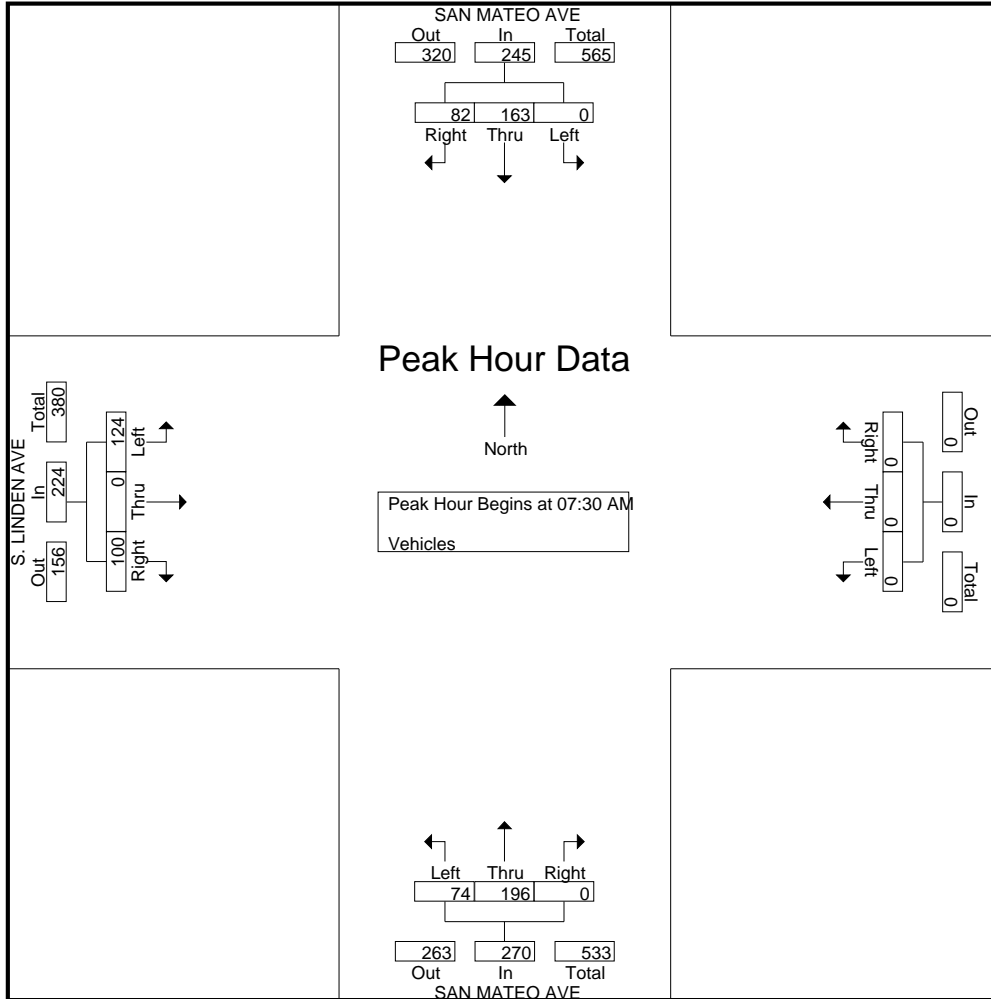

Traffic Data Service

Campbell, CA
 (408) 377-2988
 tdsbay@cs.com

File Name : 9PM FINAL
 Site Code : 00000009
 Start Date : 6/6/2013
 Page No : 1

Groups Printed- Vehicles

Start Time	SAN MATEO AVE Southbound					SAN MATEO AVE Westbound					SAN MATEO AVE Northbound					S. LINDEN AVE Eastbound					Int. Total
	Right	Thru	Left	Peds	App. Total	Right	Thru	Left	Peds	App. Total	Right	Thru	Left	Peds	App. Total	Right	Thru	Left	Peds	App. Total	
04:00 PM	30	49	0	1	80	0	0	0	0	0	0	44	23	0	67	39	0	40	2	81	228
04:15 PM	28	52	0	1	81	0	0	0	0	0	0	48	24	0	72	26	0	32	1	59	212
04:30 PM	33	47	0	1	81	0	0	0	0	0	0	55	35	0	90	31	0	34	0	65	236
04:45 PM	37	43	0	0	80	0	0	0	0	0	0	43	24	0	67	31	0	25	0	56	203
Total	128	191	0	3	322	0	0	0	0	0	0	190	106	0	296	127	0	131	3	261	879
05:00 PM	46	72	0	2	120	0	0	0	0	0	0	59	29	0	88	27	0	27	1	55	263
05:15 PM	34	62	0	0	96	0	0	0	0	0	0	46	34	0	80	20	0	20	0	40	216
05:30 PM	24	42	0	0	66	0	0	0	0	0	0	44	35	1	80	33	0	18	1	52	198
05:45 PM	18	46	0	1	65	0	0	0	0	0	0	36	31	0	67	24	0	18	2	44	176
Total	122	222	0	3	347	0	0	0	0	0	0	185	129	1	315	104	0	83	4	191	853
Grand Total	250	413	0	6	669	0	0	0	0	0	0	375	235	1	611	231	0	214	7	452	1732
Apprch %	37.4	61.7	0	0.9		0	0	0	0		0	61.4	38.5	0.2		51.1	0	47.3	1.5		
Total %	14.4	23.8	0	0.3	38.6	0	0	0	0		0	21.7	13.6	0.1	35.3	13.3	0	12.4	0.4	26.1	

Start Time	SAN MATEO AVE Southbound				SAN MATEO AVE Westbound				SAN MATEO AVE Northbound				S. LINDEN AVE Eastbound				Int. Total
	Right	Thru	Left	App. Total	Right	Thru	Left	App. Total	Right	Thru	Left	App. Total	Right	Thru	Left	App. Total	
04:30 PM	33	47	0	80	0	0	0	0	0	55	35	90	31	0	34	65	235
04:45 PM	37	43	0	80	0	0	0	0	0	43	24	67	31	0	25	56	203
05:00 PM	46	72	0	118	0	0	0	0	0	59	29	88	27	0	27	54	260
05:15 PM	34	62	0	96	0	0	0	0	0	46	34	80	20	0	20	40	216
Total Volume	150	224	0	374	0	0	0	0	0	203	122	325	109	0	106	215	914
% App. Total	40.1	59.9	0		0	0	0		0	62.5	37.5		50.7	0	49.3		
PHF	.815	.778	.000	.792	.000	.000	.000	.000	.000	.860	.871	.903	.879	.000	.779	.827	.879

Peak Hour Analysis From 04:00 PM to 05:45 PM - Peak 1 of 1

Peak Hour for Entire Intersection Begins at 04:30 PM

Traffic Data Service

Campbell, CA

(408) 377-2988

tdsbay@cs.com

File Name : 9PM FINAL

Site Code : 00000009

Start Date : 6/6/2013

Page No : 2

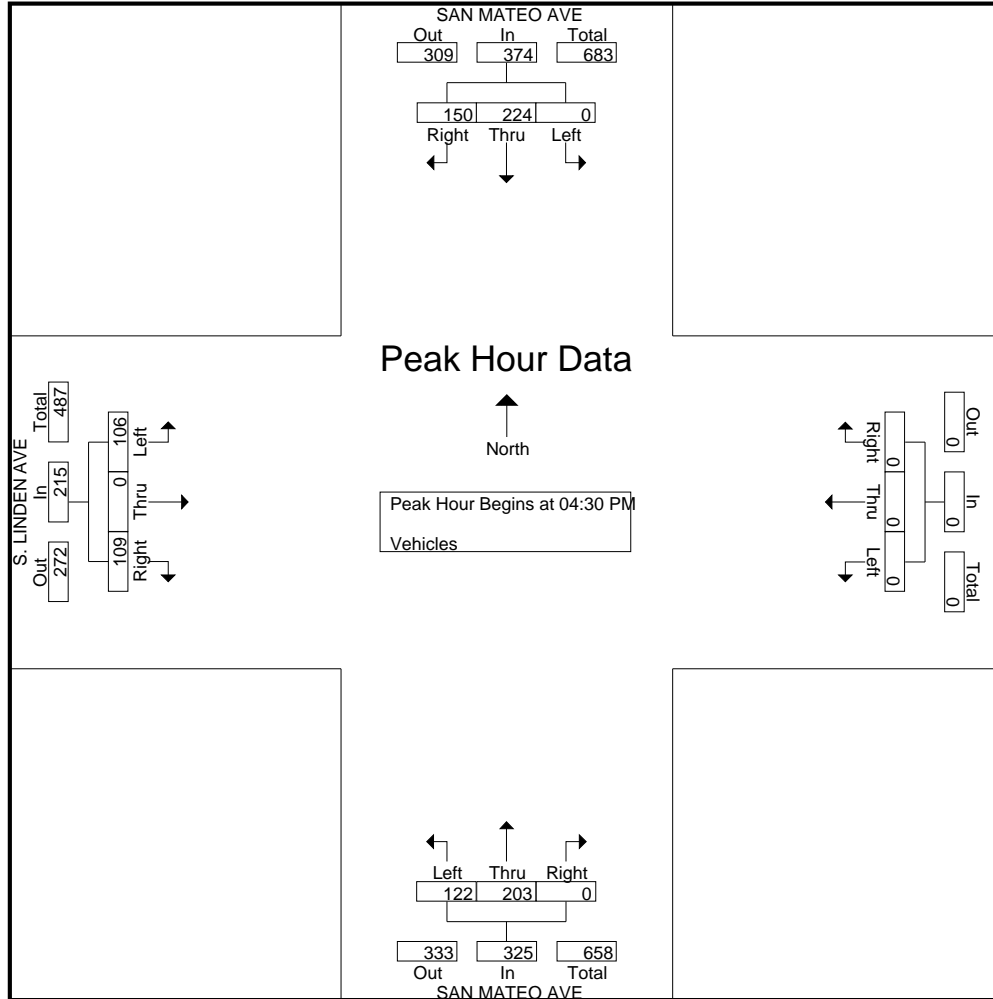

Traffic Data Service

Campbell, CA
 (408) 377-2988
 tdsbay@cs.com

File Name : 9AM FINAL
 Site Code : 00000009
 Start Date : 6/6/2013
 Page No : 1

Groups Printed- Bikes

Start Time	SAN MATEO AVE Southbound					SAN MATEO AVE Westbound					SAN MATEO AVE Northbound					S. LINDEN AVE Eastbound					Int. Total
	Right	Thru	Left	Peds	App. Total	Right	Thru	Left	Peds	App. Total	Right	Thru	Left	Peds	App. Total	Right	Thru	Left	Peds	App. Total	
07:00 AM	0	0	0	0	0	0	0	0	0	0	0	3	0	0	3	1	0	0	0	1	4
07:15 AM	0	2	0	0	2	0	0	0	0	0	0	0	0	0	0	0	0	0	0	0	2
07:30 AM	0	0	0	0	0	0	0	0	0	0	0	1	0	0	1	1	0	1	0	2	3
07:45 AM	0	1	0	0	1	0	0	0	0	0	0	0	0	0	0	0	0	1	0	1	2
Total	0	3	0	0	3	0	0	0	0	0	0	4	0	0	4	2	0	2	0	4	11
08:00 AM	1	0	0	0	1	0	0	0	0	0	0	0	0	0	0	0	0	1	0	1	2
08:15 AM	0	0	0	0	0	0	0	0	0	0	0	0	0	0	0	0	0	3	0	3	3
08:30 AM	0	1	0	0	1	0	0	0	0	0	0	0	0	0	0	0	0	0	0	0	1
08:45 AM	0	1	0	0	1	0	0	0	0	0	0	1	0	0	1	1	0	1	0	2	4
Total	1	2	0	0	3	0	0	0	0	0	0	1	0	0	1	1	0	5	0	6	10
Grand Total	1	5	0	0	6	0	0	0	0	0	0	5	0	0	5	3	0	7	0	10	21
Apprch %	16.7	83.3	0	0		0	0	0	0		0	100	0	0		30	0	70	0		
Total %	4.8	23.8	0	0	28.6	0	0	0	0	0	0	23.8	0	0	23.8	14.3	0	33.3	0	47.6	

Start Time	SAN MATEO AVE Southbound					SAN MATEO AVE Westbound					SAN MATEO AVE Northbound					S. LINDEN AVE Eastbound					Int. Total
	Right	Thru	Left	Peds	App. Total	Right	Thru	Left	Peds	App. Total	Right	Thru	Left	Peds	App. Total	Right	Thru	Left	Peds	App. Total	
07:00 AM	0	0	0	0	0	0	0	0	0	0	0	3	0	0	3	1	0	0	0	1	4
07:15 AM	0	2	0	0	2	0	0	0	0	0	0	0	0	0	0	0	0	0	0	0	2
07:30 AM	0	0	0	0	0	0	0	0	0	0	0	1	0	0	1	1	0	1	0	2	3
07:45 AM	0	1	0	0	1	0	0	0	0	0	0	0	0	0	0	0	0	1	0	1	2
Total Volume	0	3	0	0	3	0	0	0	0	0	0	4	0	0	4	2	0	2	0	4	11
% App. Total	0	100	0	0		0	0	0	0		0	100	0	0		50	0	50	0		
PHF	.000	.375	.000	.000	.375	.000	.000	.000	.000	.000	.000	.333	.000	.333	.500	.000	.500	.500	.500	.688	

Peak Hour Analysis From 07:00 AM to 08:45 AM - Peak 1 of 1

Peak Hour for Entire Intersection Begins at 07:00 AM

Traffic Data Service

Campbell, CA

(408) 377-2988

tdsbay@cs.com

File Name : 9AM FINAL

Site Code : 00000009

Start Date : 6/6/2013

Page No : 2

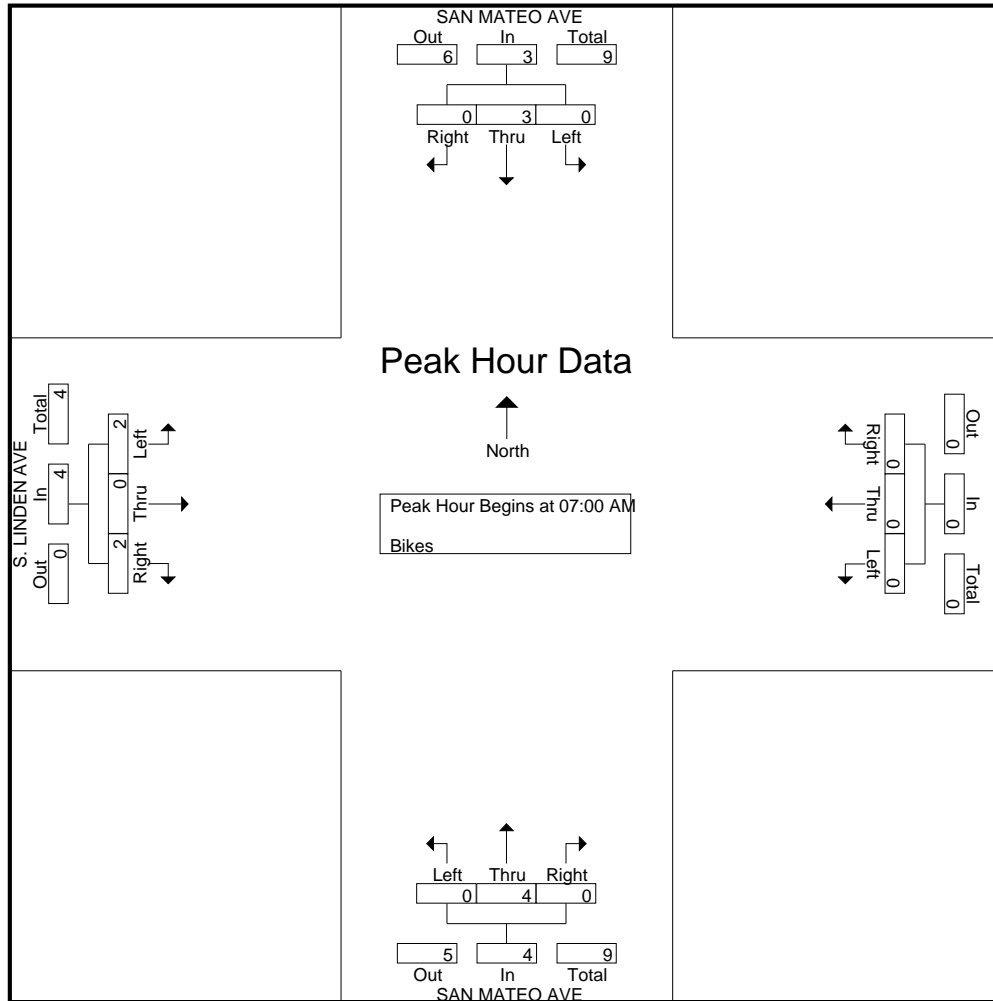

Traffic Data Service

Campbell, CA
 (408) 377-2988
 tdsbay@cs.com

File Name : 10AM FINAL
 Site Code : 00000010
 Start Date : 6/6/2013
 Page No : 1

Groups Printed- Bikes

Start Time	HERMAN ST Southbound					SCOTT ST Westbound					HERMAN ST Northbound					SCOTT ST Eastbound					Int. Total
	Right	Thru	Left	Peds	App. Total	Right	Thru	Left	Peds	App. Total	Right	Thru	Left	Peds	App. Total	Right	Thru	Left	Peds	App. Total	
07:00 AM	0	0	0	0	0	0	0	0	0	0	0	0	0	0	0	0	0	0	0	0	0
07:15 AM	0	0	0	0	0	0	0	0	0	0	0	0	0	0	0	0	0	0	0	0	0
07:30 AM	0	0	1	0	1	0	0	0	0	0	0	0	0	0	0	0	0	0	0	0	1
07:45 AM	0	0	1	0	1	0	0	0	0	0	1	0	0	0	1	0	0	0	0	0	2
Total	0	0	2	0	2	0	0	0	0	0	1	0	0	0	1	0	0	0	0	0	3
08:00 AM	0	0	0	0	0	0	0	0	0	0	1	0	0	0	1	0	0	0	0	0	1
08:15 AM	0	1	0	0	1	0	0	0	0	0	2	1	0	0	3	0	1	0	0	1	5
08:30 AM	0	0	0	0	0	0	1	0	0	1	0	1	0	0	1	0	1	0	0	1	3
08:45 AM	0	0	0	0	0	0	0	0	0	0	0	0	0	0	0	0	0	0	0	0	0
Total	0	1	0	0	1	0	1	0	0	1	3	2	0	0	5	0	2	0	0	2	9
Grand Total	0	1	2	0	3	0	1	0	0	1	4	2	0	0	6	0	2	0	0	2	12
Apprch %	0	33.3	66.7	0		0	100	0	0		66.7	33.3	0	0		0	100	0	0		
Total %	0	8.3	16.7	0	25	0	8.3	0	0	8.3	33.3	16.7	0	0	50	0	16.7	0	0	16.7	

Start Time	HERMAN ST Southbound				SCOTT ST Westbound				HERMAN ST Northbound				SCOTT ST Eastbound				Int. Total
	Right	Thru	Left	App. Total	Right	Thru	Left	App. Total	Right	Thru	Left	App. Total	Right	Thru	Left	App. Total	
07:45 AM	0	0	1	1	0	0	0	0	1	0	0	1	0	0	0	0	2
08:00 AM	0	0	0	0	0	0	0	0	1	0	0	1	0	0	0	0	1
08:15 AM	0	1	0	1	0	0	0	0	2	1	0	3	0	1	0	1	5
08:30 AM	0	0	0	0	0	1	0	1	0	1	0	1	0	1	0	1	3
Total Volume	0	1	1	2	0	1	0	1	4	2	0	6	0	2	0	2	11
% App. Total	0	50	50		0	100	0		66.7	33.3	0		0	100	0		
PHF	.000	.250	.250	.500	.000	.250	.000	.250	.500	.500	.000	.500	.000	.500	.000	.500	.550

Peak Hour Analysis From 07:00 AM to 08:45 AM - Peak 1 of 1

Peak Hour for Entire Intersection Begins at 07:45 AM

Traffic Data Service

Campbell, CA

(408) 377-2988

tdsbay@cs.com

File Name : 10AM FINAL

Site Code : 00000010

Start Date : 6/6/2013

Page No : 2

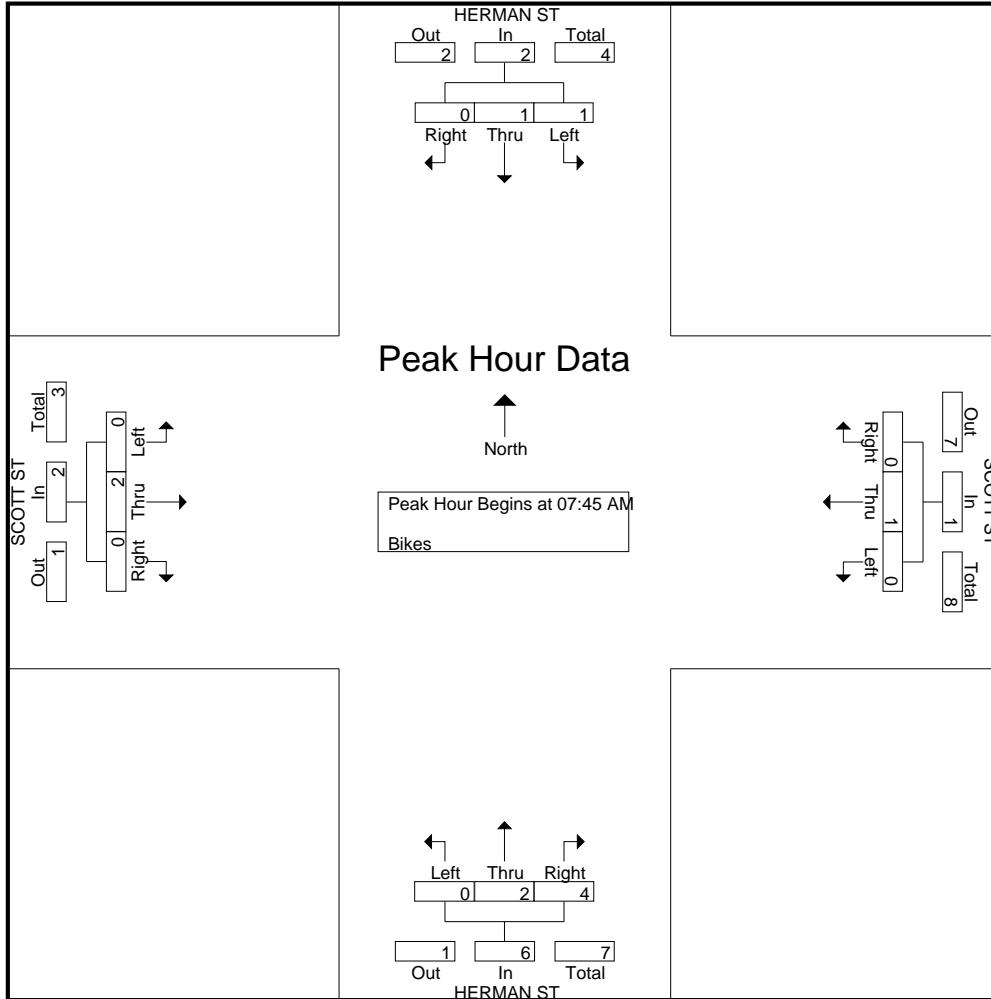

Traffic Data Service

Campbell, CA
 (408) 377-2988
 tdsbay@cs.com

File Name : 10AM FINAL
 Site Code : 00000010
 Start Date : 6/6/2013
 Page No : 1

Groups Printed- Vehicles

Start Time	HERMAN ST Southbound					SCOTT ST Westbound					HERMAN ST Northbound					SCOTT ST Eastbound					Int. Total
	Right	Thru	Left	Peds	App. Total	Right	Thru	Left	Peds	App. Total	Right	Thru	Left	Peds	App. Total	Right	Thru	Left	Peds	App. Total	
07:00 AM	0	20	3	0	23	1	0	16	0	17	20	17	2	3	42	1	2	0	1	4	86
07:15 AM	2	19	3	0	24	8	0	12	0	20	37	26	0	10	73	4	2	0	4	10	127
07:30 AM	1	25	9	1	36	14	1	7	0	22	28	27	1	4	60	0	5	1	1	7	125
07:45 AM	1	25	5	4	35	9	1	14	0	24	34	31	0	3	68	4	4	0	0	8	135
Total	4	89	20	5	118	32	2	49	0	83	119	101	3	20	243	9	13	1	6	29	473
08:00 AM	0	15	7	0	22	11	2	13	0	26	36	27	0	1	64	1	6	0	0	7	119
08:15 AM	0	28	4	1	33	10	0	5	1	16	31	23	0	4	58	0	0	0	0	0	107
08:30 AM	0	22	6	0	28	9	0	18	0	27	21	24	0	6	51	0	2	1	2	5	111
08:45 AM	0	19	6	2	27	3	2	12	0	17	35	33	1	3	72	2	3	0	0	5	121
Total	0	84	23	3	110	33	4	48	1	86	123	107	1	14	245	3	11	1	2	17	458
Grand Total	4	173	43	8	228	65	6	97	1	169	242	208	4	34	488	12	24	2	8	46	931
Apprch %	1.8	75.9	18.9	3.5		38.5	3.6	57.4	0.6		49.6	42.6	0.8	7		26.1	52.2	4.3	17.4		
Total %	0.4	18.6	4.6	0.9	24.5	7	0.6	10.4	0.1	18.2	26	22.3	0.4	3.7	52.4	1.3	2.6	0.2	0.9	4.9	

Start Time	HERMAN ST Southbound				SCOTT ST Westbound				HERMAN ST Northbound				SCOTT ST Eastbound				Int. Total
	Right	Thru	Left	App. Total	Right	Thru	Left	App. Total	Right	Thru	Left	App. Total	Right	Thru	Left	App. Total	
Peak Hour Analysis From 07:00 AM to 08:45 AM - Peak 1 of 1																	
Peak Hour for Entire Intersection Begins at 07:15 AM																	
07:15 AM	2	19	3	24	8	0	12	20	37	26	0	63	4	2	0	6	113
07:30 AM	1	25	9	35	14	1	7	22	28	27	1	56	0	5	1	6	119
07:45 AM	1	25	5	31	9	1	14	24	34	31	0	65	4	4	0	8	128
08:00 AM	0	15	7	22	11	2	13	26	36	27	0	63	1	6	0	7	118
Total Volume	4	84	24	112	42	4	46	92	135	111	1	247	9	17	1	27	478
% App. Total	3.6	75	21.4		45.7	4.3	50		54.7	44.9	0.4		33.3	63	3.7		
PHF	.500	.840	.667	.800	.750	.500	.821	.885	.912	.895	.250	.950	.563	.708	.250	.844	.934

Traffic Data Service

Campbell, CA
(408) 377-2988
tdsbay@cs.com

File Name : 10AM FINAL
Site Code : 00000010
Start Date : 6/6/2013
Page No : 2

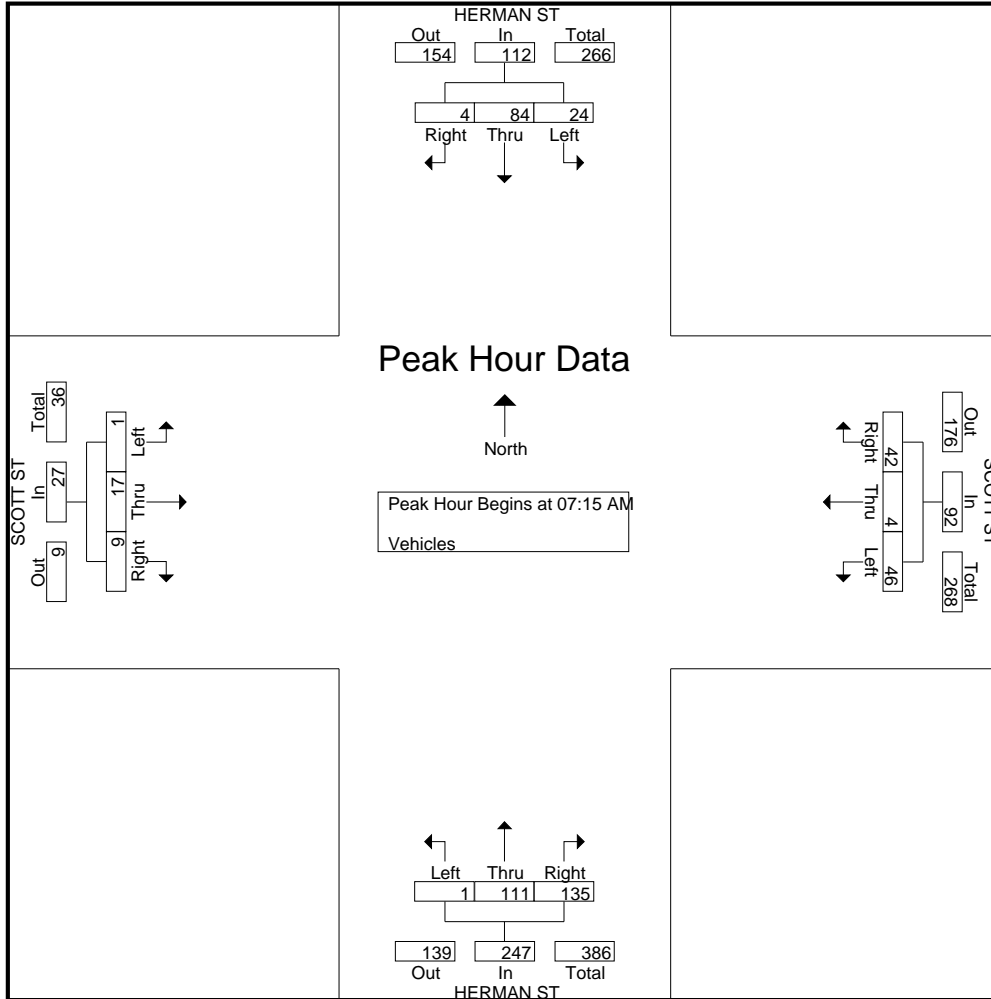

All Traffic Data

(916) 771-8700

City of San Bruno

File Name : 12-7153-001 Montgomery-Scott

Site Code : 00000000

Start Date : 4/18/2012

Page No : 1

Groups Printed- Unshifted

Start Time	Montgomery Avenue Southbound				Scott Street Westbound				Montgomery Avenue Northbound				Scott Street Eastbound				Int. Total
	Left	Thru	Right	App. Total	Left	Thru	Right	App. Total	Left	Thru	Right	App. Total	Left	Thru	Right	App. Total	
07:00	1	0	0	1	1	7	4	12	1	0	0	1	0	17	1	18	32
07:15	1	0	1	2	1	14	2	17	6	0	3	9	8	28	0	36	64
07:30	2	0	0	2	1	25	0	26	4	1	2	7	7	37	5	49	84
07:45	1	1	6	8	4	22	1	27	3	1	4	8	5	34	5	44	87
Total	5	1	7	13	7	68	7	82	14	2	9	25	20	116	11	147	267
08:00	2	1	0	3	0	23	1	24	2	0	0	2	8	30	3	41	70
08:15	1	0	5	6	3	13	1	17	4	1	3	8	11	32	8	51	82
08:30	0	0	2	2	2	19	1	22	5	1	1	7	5	33	8	46	77
08:45	1	0	3	4	3	20	2	25	6	0	1	7	6	31	4	41	77
Total	4	1	10	15	8	75	5	88	17	2	5	24	30	126	23	179	306
16:00	3	2	10	15	0	33	0	33	5	3	6	14	3	33	6	42	104
16:15	2	1	2	5	3	35	1	39	3	0	5	8	2	33	9	44	96
16:30	0	0	2	2	2	47	0	49	6	0	6	12	6	32	3	41	104
16:45	1	1	6	8	1	38	1	40	7	0	2	9	8	27	7	42	99
Total	6	4	20	30	6	153	2	161	21	3	19	43	19	125	25	169	403
17:00	1	1	4	6	7	43	1	51	7	2	5	14	3	31	10	44	115
17:15	5	5	6	16	1	31	1	33	8	1	4	13	2	34	4	40	102
17:30	1	3	6	10	2	38	1	41	12	2	4	18	1	21	9	31	100
17:45	1	1	7	9	2	29	3	34	9	1	1	11	6	26	8	40	94
Total	8	10	23	41	12	141	6	159	36	6	14	56	12	112	31	155	411
Grand Total	23	16	60	99	33	437	20	490	88	13	47	148	81	479	90	650	1387
Apprch %	23.2	16.2	60.6		6.7	89.2	4.1		59.5	8.8	31.8		12.5	73.7	13.8		
Total %	1.7	1.2	4.3	7.1	2.4	31.5	1.4	35.3	6.3	0.9	3.4	10.7	5.8	34.5	6.5	46.9	

Start Time	Montgomery Avenue Southbound				Scott Street Westbound				Montgomery Avenue Northbound				Scott Street Eastbound				Int. Total
	Left	Thru	Right	App. Total	Left	Thru	Right	App. Total	Left	Thru	Right	App. Total	Left	Thru	Right	App. Total	
Peak Hour Analysis From 07:00 to 08:45 - Peak 1 of 1																	
Peak Hour for Entire Intersection Begins at 07:30																	
07:30	2	0	0	2	1	25	0	26	4	1	2	7	7	37	5	49	84
07:45	1	1	6	8	4	22	1	27	3	1	4	8	5	34	5	44	87
08:00	2	1	0	3	0	23	1	24	2	0	0	2	8	30	3	41	70
08:15	1	0	5	6	3	13	1	17	4	1	3	8	11	32	8	51	82
Total Volume	6	2	11	19	8	83	3	94	13	3	9	25	31	133	21	185	323
% App. Total	31.6	10.5	57.9		8.5	88.3	3.2		52	12	36		16.8	71.9	11.4		

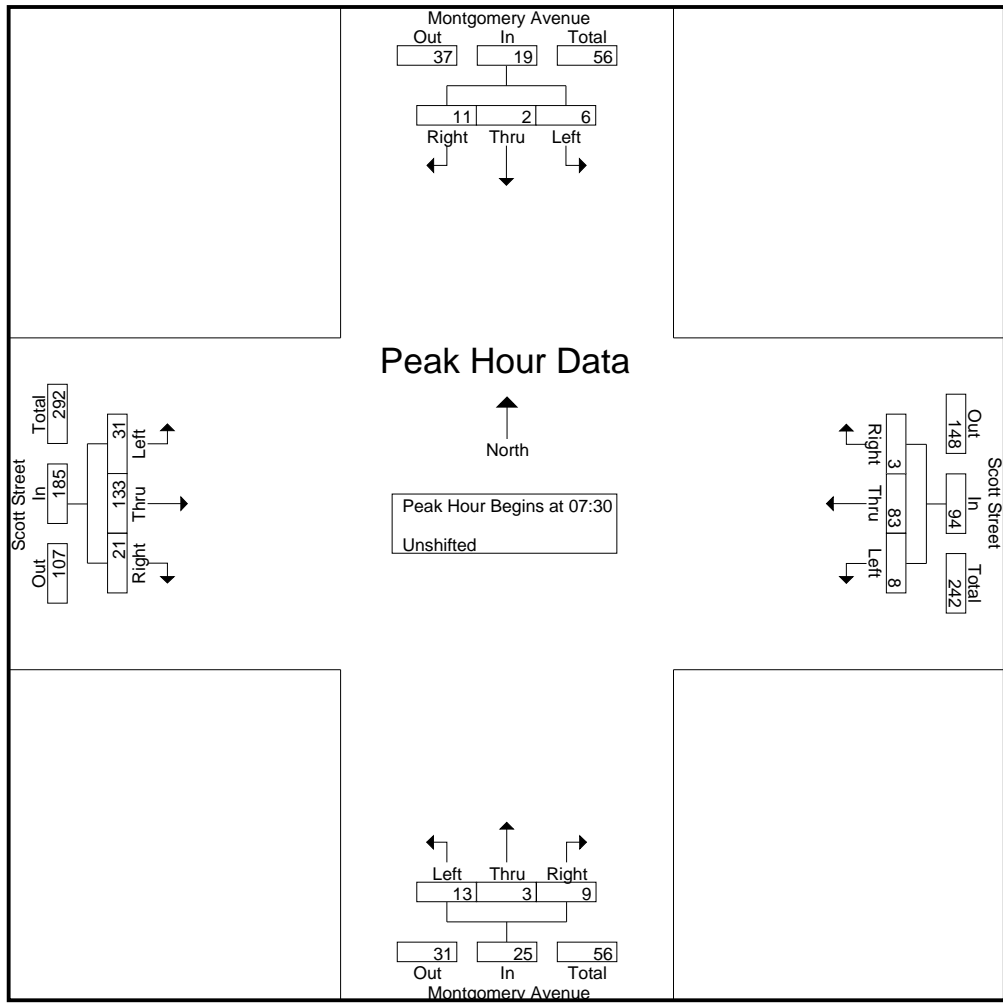

Peak Hour Analysis From 16:00 to 17:45 - Peak 1 of 1
 Peak Hour for Entire Intersection Begins at 16:30

16:30	0	0	2	2	2	47	0	49	6	0	6	12	6	32	3	41	104
16:45	1	1	6	8	1	38	1	40	7	0	2	9	8	27	7	42	99
17:00	1	1	4	6	7	43	1	51	7	2	5	14	3	31	10	44	115
17:15	5	5	6	16	1	31	1	33	8	1	4	13	2	34	4	40	102
Total Volume	7	7	18	32	11	159	3	173	28	3	17	48	19	124	24	167	420
% App. Total	21.9	21.9	56.2		6.4	91.9	1.7		58.3	6.2	35.4		11.4	74.3	14.4		
PHF	.350	.350	.750	.500	.393	.846	.750	.848	.875	.375	.708	.857	.594	.912	.600	.949	.913

All Traffic Data

(916) 771-8700

City of San Bruno

File Name : 12-7153-001 Montgomery-Scott

Site Code : 00000000

Start Date : 4/18/2012

Page No : 3

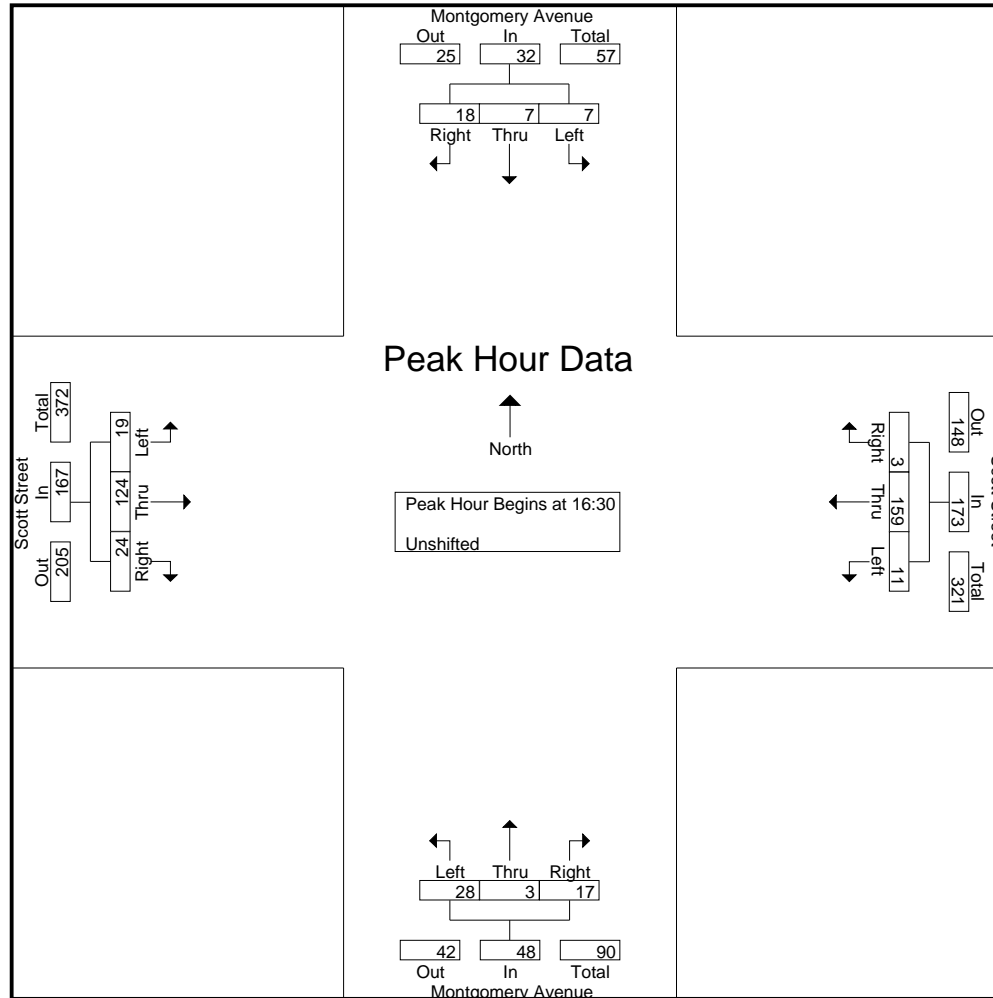

Traffic Data Service

Campbell, CA
 (408) 377-2988
 tdsbay@cs.com

File Name : 10PM FINAL
 Site Code : 00000010
 Start Date : 6/6/2013
 Page No : 1

Groups Printed- Vehicles

Start Time	HERMAN ST Southbound					SCOTT ST Westbound					HERMAN ST Northbound					SCOTT ST Eastbound					Int. Total
	Right	Thru	Left	Peds	App. Total	Right	Thru	Left	Peds	App. Total	Right	Thru	Left	Peds	App. Total	Right	Thru	Left	Peds	App. Total	
04:00 PM	3	35	5	0	43	5	4	36	0	45	27	20	0	5	52	0	2	1	3	6	146
04:15 PM	0	32	6	4	42	2	0	36	0	38	37	25	3	7	72	1	0	0	3	4	156
04:30 PM	2	34	14	2	52	8	1	31	0	40	27	20	2	8	57	1	0	0	2	3	152
04:45 PM	1	47	7	3	58	4	3	23	0	30	34	28	1	5	68	3	3	1	1	8	164
Total	6	148	32	9	195	19	8	126	0	153	125	93	6	25	249	5	5	2	9	21	618
05:00 PM	0	38	16	0	54	5	4	41	0	50	23	25	1	9	58	2	4	1	2	9	171
05:15 PM	4	32	9	4	49	4	3	38	0	45	26	30	1	4	61	0	2	0	1	3	158
05:30 PM	3	36	10	2	51	10	3	31	0	44	34	23	0	6	63	1	0	4	1	6	164
05:45 PM	0	43	8	0	51	4	1	37	0	42	28	25	0	9	62	3	2	0	2	7	162
Total	7	149	43	6	205	23	11	147	0	181	111	103	2	28	244	6	8	5	6	25	655
Grand Total	13	297	75	15	400	42	19	273	0	334	236	196	8	53	493	11	13	7	15	46	1273
Apprch %	3.2	74.2	18.8	3.8		12.6	5.7	81.7	0		47.9	39.8	1.6	10.8		23.9	28.3	15.2	32.6		
Total %	1	23.3	5.9	1.2	31.4	3.3	1.5	21.4	0	26.2	18.5	15.4	0.6	4.2	38.7	0.9	1	0.5	1.2	3.6	

Start Time	HERMAN ST Southbound					SCOTT ST Westbound					HERMAN ST Northbound					SCOTT ST Eastbound					Int. Total
	Right	Thru	Left	Peds	App. Total	Right	Thru	Left	Peds	App. Total	Right	Thru	Left	Peds	App. Total	Right	Thru	Left	Peds	App. Total	
04:45 PM	1	47	7		55	4	3	23		30	34	28	1		63	3	3	1		7	155
05:00 PM	0	38	16		54	5	4	41		50	23	25	1		49	2	4	1		7	160
05:15 PM	4	32	9		45	4	3	38		45	26	30	1		57	0	2	0		2	149
05:30 PM	3	36	10		49	10	3	31		44	34	23	0		57	1	0	4		5	155
Total Volume	8	153	42		203	23	13	133		169	117	106	3		226	6	9	6		21	619
% App. Total	3.9	75.4	20.7			13.6	7.7	78.7			51.8	46.9	1.3			28.6	42.9	28.6			
PHF	.500	.814	.656		.923	.575	.813	.811		.845	.860	.883	.750		.897	.500	.563	.375		.750	.967

Peak Hour Analysis From 04:00 PM to 05:45 PM - Peak 1 of 1

Peak Hour for Entire Intersection Begins at 04:45 PM

Traffic Data Service

Campbell, CA
(408) 377-2988
tdsbay@cs.com

File Name : 10PM FINAL
Site Code : 00000010
Start Date : 6/6/2013
Page No : 2

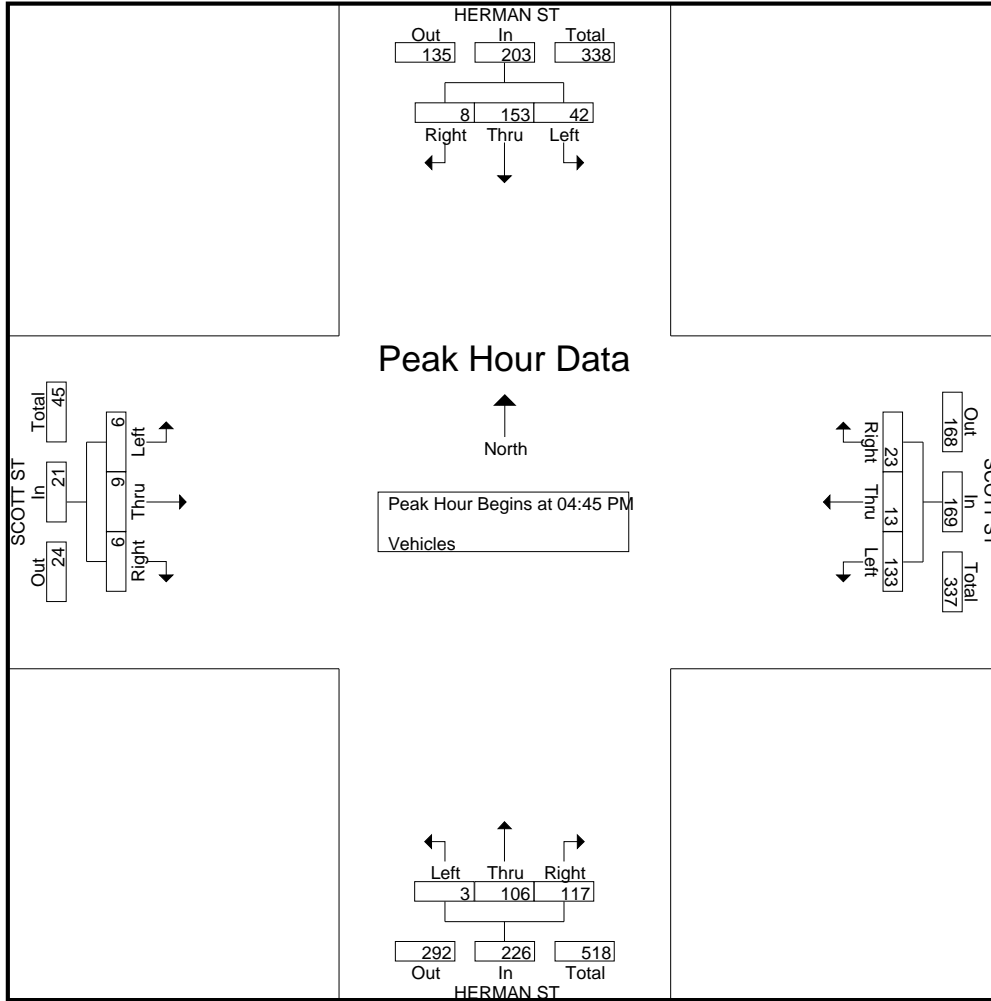

Traffic Data Service

Campbell, CA
 (408) 377-2988
 tdsbay@cs.com

File Name : 10PM FINAL
 Site Code : 00000010
 Start Date : 6/6/2013
 Page No : 1

Groups Printed- Bikes

Start Time	HERMAN ST Southbound					SCOTT ST Westbound					HERMAN ST Northbound					SCOTT ST Eastbound					Int. Total
	Right	Thru	Left	Peds	App. Total	Right	Thru	Left	Peds	App. Total	Right	Thru	Left	Peds	App. Total	Right	Thru	Left	Peds	App. Total	
04:00 PM	0	0	0	0	0	0	0	0	0	0	1	0	0	0	1	0	1	0	0	1	2
04:15 PM	0	0	0	0	0	0	1	0	0	1	0	0	0	0	0	0	0	0	0	0	1
04:30 PM	0	1	0	0	1	1	1	0	0	2	0	0	0	0	0	0	0	0	0	0	3
04:45 PM	0	1	1	0	2	2	0	0	0	2	0	1	0	0	1	0	0	0	0	0	5
Total	0	2	1	0	3	3	2	0	0	5	1	1	0	0	2	0	1	0	0	1	11
05:00 PM	0	1	0	0	1	0	1	0	0	1	0	0	0	0	0	0	0	0	0	0	2
05:15 PM	0	0	0	0	0	0	0	0	0	0	0	1	0	0	1	0	0	0	0	0	1
05:30 PM	1	1	0	0	2	2	3	0	0	5	1	0	0	0	1	0	0	0	0	0	8
05:45 PM	0	0	0	0	0	0	0	0	0	0	0	0	0	0	0	0	0	0	0	0	0
Total	1	2	0	0	3	2	4	0	0	6	1	1	0	0	2	0	0	0	0	0	11
Grand Total	1	4	1	0	6	5	6	0	0	11	2	2	0	0	4	0	1	0	0	1	22
Apprch %	16.7	66.7	16.7	0		45.5	54.5	0	0		50	50	0	0		0	100	0	0		
Total %	4.5	18.2	4.5	0	27.3	22.7	27.3	0	0	50	9.1	9.1	0	0	18.2	0	4.5	0	0	4.5	

Start Time	HERMAN ST Southbound				SCOTT ST Westbound				HERMAN ST Northbound				SCOTT ST Eastbound				Int. Total
	Right	Thru	Left	App. Total	Right	Thru	Left	App. Total	Right	Thru	Left	App. Total	Right	Thru	Left	App. Total	
04:45 PM	0	1	1	2	2	0	0	2	0	1	0	1	0	0	0	0	5
05:00 PM	0	1	0	1	0	1	0	1	0	0	0	0	0	0	0	0	2
05:15 PM	0	0	0	0	0	0	0	0	0	1	0	1	0	0	0	0	1
05:30 PM	1	1	0	2	2	3	0	5	1	0	0	1	0	0	0	0	8
Total Volume	1	3	1	5	4	4	0	8	1	2	0	3	0	0	0	0	16
% App. Total	20	60	20		50	50	0		33.3	66.7	0		0	0	0		
PHF	.250	.750	.250	.625	.500	.333	.000	.400	.250	.500	.000	.750	.000	.000	.000	.000	.500

Peak Hour Analysis From 04:00 PM to 05:45 PM - Peak 1 of 1

Peak Hour for Entire Intersection Begins at 04:45 PM

Traffic Data Service

Campbell, CA

(408) 377-2988

tdsbay@cs.com

File Name : 10PM FINAL

Site Code : 00000010

Start Date : 6/6/2013

Page No : 2

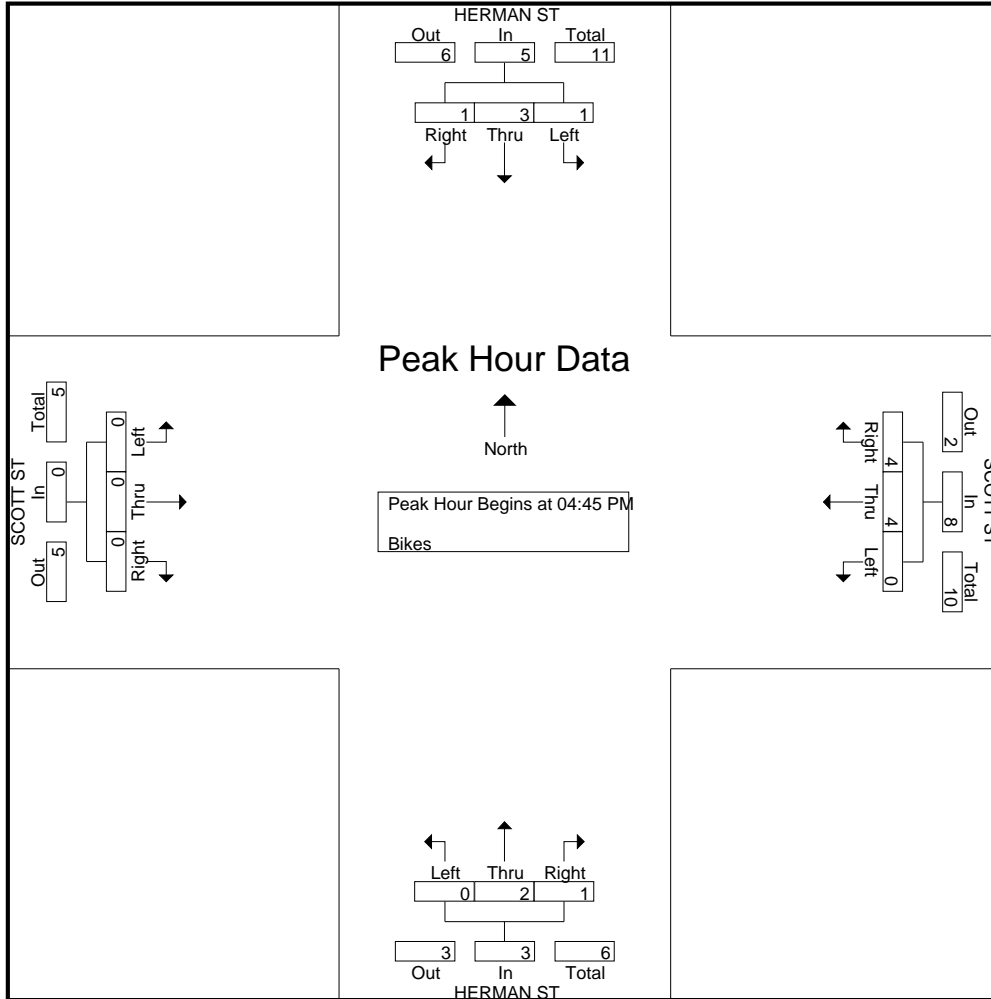

INTERSECTION CAR/PED/BIKE TRAFFIC COUNT RESULTS SUMMARY

CLIENT: KIMLEY-HORN AND ASSOCIATES
 PROJECT: SAN BRUNO GRADE SEPARATION
 DATE: WEDNESDAY MAY 20, 2009
 PERIOD: 7:00 AM TO 9:00 AM
 INTERSECTION: N/S SAN MATEO AVENUE
 E/W SAN BRUNO AVENUE
 CITY: SAN BRUNO

VEHICLE COUNTS													
15 MIN COUNTS	1	2	3	4	5	6	7	8	9	10	11	12	TOTAL
PERIOD	SBRT	SBTH	SBLT	WBRT	WBTH	WBLT	NBRT	NBTH	NBLT	EBRT	EBTH	EBLT	TOTAL
700-715	8	3	14	30	46	18	36	12	2	0	73	0	242
715-730	10	6	14	17	51	19	28	11	1	0	83	0	240
730-745	7	6	20	41	74	13	39	11	1	0	76	1	289
745-800	4	7	10	22	69	20	38	23	2	1	108	0	304
800-815	9	6	9	28	70	25	40	21	2	0	84	1	295
815-830	13	7	12	14	58	19	36	19	2	0	100	0	280
830-845	14	10	10	19	43	14	28	6	6	0	86	0	236
845-900	5	11	12	26	59	20	30	21	1	1	106	0	292
HOUR TOTALS	1	2	3	4	5	6	7	8	9	10	11	12	TOTAL
PERIOD	SBRT	SBTH	SBLT	WBRT	WBTH	WBLT	NBRT	NBTH	NBLT	EBRT	EBTH	EBLT	TOTAL
700-800	29	22	58	110	240	70	141	57	6	1	340	1	1075
715-815	30	25	53	108	264	77	145	66	6	1	351	2	1128
730-830	33	26	51	105	271	77	153	74	7	1	368	2	1168
745-845	40	30	41	83	240	78	142	69	12	1	378	1	1115
800-900	41	34	43	87	230	78	134	67	11	1	376	1	1103

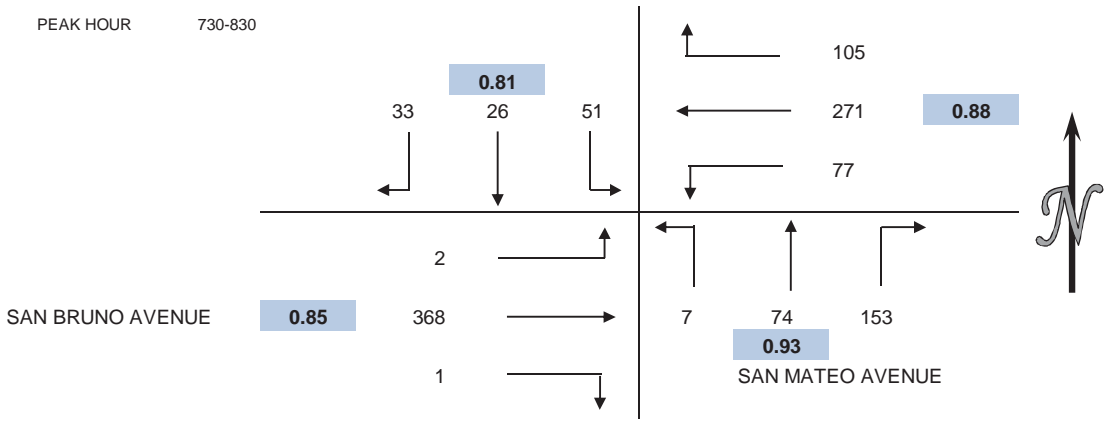

PEDESTRIAN COUNTS					
15 MIN COUNTS	NORTH LEG	EAST LEG	SOUTH LEG	WEST LEG	TOTAL
PERIOD	NORTH LEG	EAST LEG	SOUTH LEG	WEST LEG	TOTAL
700-715	1	0	1	0	2
715-730	2	0	0	0	2
730-745	3	1	0	0	4
745-800	3	1	1	0	5
800-815	2	3	0	0	5
815-830	4	3	0	0	7
830-845	2	0	1	1	4
845-900	1	3	0	0	4
HOUR TOTALS	NORTH LEG	EAST LEG	SOUTH LEG	WEST LEG	TOTAL
PERIOD	NORTH LEG	EAST LEG	SOUTH LEG	WEST LEG	TOTAL
700-800	9	2	2	0	13
715-815	10	5	1	0	16
730-830	12	8	1	0	21
745-845	11	7	2	1	21
800-900	9	9	1	1	20

BICYCLE COUNTS					
15 MIN COUNTS	NORTH LEG	EAST LEG	SOUTH LEG	WEST LEG	TOTAL
PERIOD	NORTH LEG	EAST LEG	SOUTH LEG	WEST LEG	TOTAL
700-715	1	0	2	0	3
715-730	2	1	0	2	5
730-745	1	1	0	0	2
745-800	1	0	0	0	1
800-815	2	0	0	0	2
815-830	0	0	0	0	0
830-845	0	1	2	0	3
845-900	0	0	0	0	0
HOUR TOTALS	NORTH LEG	EAST LEG	SOUTH LEG	WEST LEG	TOTAL
PERIOD	NORTH LEG	EAST LEG	SOUTH LEG	WEST LEG	TOTAL
700-800	5	2	2	2	11
715-815	6	2	0	2	10
730-830	4	1	0	0	5
745-845	3	1	2	0	6
800-900	2	1	2	0	5

INTERSECTION CAR/PED/BIKE TRAFFIC COUNT RESULTS SUMMARY

CLIENT: KIMLEY-HORN AND ASSOCIATES
 PROJECT: SAN BRUNO GRADE SEPARATION
 DATE: WEDNESDAY MAY 20, 2009
 PERIOD: 4:00 PM TO 6:00 PM
 INTERSECTION: N/S SAN MATEO AVENUE
 E/W SAN BRUNO AVENUE
 CITY: SAN BRUNO

VEHICLE COUNTS													
15 MIN COUNTS	1	2	3	4	5	6	7	8	9	10	11	12	TOTAL
PERIOD	SBRT	SBTH	SBLT	WBRT	WBTH	WBLT	NBRT	NBTH	NBLT	EBRT	EBTH	EBLT	TOTAL
400-415	26	16	27	24	99	31	33	14	6	0	91	0	367
415-430	23	15	20	20	126	35	31	20	2	0	101	0	393
430-445	31	13	9	20	117	42	38	9	7	0	81	1	368
445-500	25	22	10	16	130	31	40	12	3	0	91	1	381
500-515	19	22	25	18	108	34	34	15	4	0	101	0	380
515-530	29	19	31	17	118	38	30	17	5	0	79	0	383
530-545	23	22	19	5	119	24	11	14	0	0	89	0	326
545-600	14	20	16	14	118	34	53	17	5	0	102	1	394
HOURLY TOTALS	1	2	3	4	5	6	7	8	9	10	11	12	TOTAL
PERIOD	SBRT	SBTH	SBLT	WBRT	WBTH	WBLT	NBRT	NBTH	NBLT	EBRT	EBTH	EBLT	TOTAL
400-500	105	66	66	80	472	139	142	55	18	0	364	2	1509
415-515	98	72	64	74	481	142	143	56	16	0	374	2	1522
430-530	104	76	75	71	473	145	142	53	19	0	352	2	1512
445-545	96	85	85	56	475	127	115	58	12	0	360	1	1470
500-600	85	83	91	54	463	130	128	63	14	0	371	1	1483

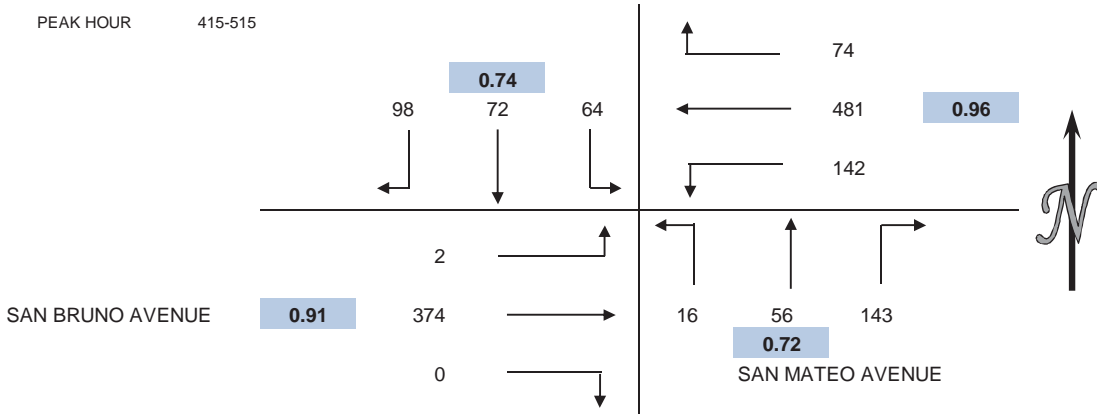

PEDESTRIAN COUNTS					
15 MIN COUNTS	NORTH LEG	EAST LEG	SOUTH LEG	WEST LEG	TOTAL
PERIOD	NORTH LEG	EAST LEG	SOUTH LEG	WEST LEG	TOTAL
400-415	5	0	0	0	5
415-430	3	0	1	0	4
430-445	5	1	0	0	6
445-500	2	0	0	0	2
500-515	2	0	0	2	4
515-530	3	2	0	0	5
530-545	0	1	3	0	4
545-600	1	0	3	0	4
HOURLY TOTALS	NORTH LEG	EAST LEG	SOUTH LEG	WEST LEG	TOTAL
PERIOD	NORTH LEG	EAST LEG	SOUTH LEG	WEST LEG	TOTAL
400-500	15	1	1	0	17
415-515	12	1	1	2	16
430-530	12	3	0	2	17
445-545	7	3	3	2	15
500-600	6	3	6	2	17

BICYCLE COUNTS					
15 MIN COUNTS	NORTH LEG	EAST LEG	SOUTH LEG	WEST LEG	TOTAL
PERIOD	NORTH LEG	EAST LEG	SOUTH LEG	WEST LEG	TOTAL
400-415	0	2	1	1	4
415-430	1	0	0	0	1
430-445	0	0	0	1	1
445-500	0	0	0	0	0
500-515	0	1	0	1	2
515-530	0	2	0	1	3
530-545	2	1	0	0	3
545-600	2	1	0	0	3
HOURLY TOTALS	NORTH LEG	EAST LEG	SOUTH LEG	WEST LEG	TOTAL
PERIOD	NORTH LEG	EAST LEG	SOUTH LEG	WEST LEG	TOTAL
400-500	1	2	1	2	6
415-515	1	1	0	2	4
430-530	0	3	0	3	6
445-545	2	4	0	2	8
500-600	4	5	0	2	11

INTERSECTION CAR/PED/BIKE TRAFFIC COUNT RESULTS SUMMARY

CLIENT: FEHR & PEERS
 PROJECT: CALTRAIN TRAFFIC COUNTS
 DATE: WEDNESDAY MAY 22, 2013
 PERIOD: 7:00 AM TO 9:00 AM
 INTERSECTION: N/S EL CAMINO REAL
 E/W MILLBRAE AVENUE
 CITY: MILLBRAE

VEHICLE COUNTS													
15 MIN COUNTS	1	2	3	4	5	6	7	8	9	10	11	12	TOTAL
PERIOD	SBRT	SBTH	SBLT	WBRT	WBTH	WBLT	NBRT	NBTH	NBLT	EBRT	EBTH	EBLT	
700-715	2	96	135	114	16	64	106	45	2	1	108	11	700
715-730	2	112	150	122	32	67	125	49	1	1	112	15	788
730-745	1	144	134	119	38	70	156	63	5	0	123	15	868
745-800	8	154	164	132	55	128	141	79	6	4	148	15	1034
800-815	13	189	177	109	54	93	128	77	5	7	160	11	1023
815-830	6	193	169	130	47	91	142	93	4	7	176	11	1069
830-845	5	164	158	112	56	112	138	105	7	2	158	21	1038
845-900	6	188	161	133	37	118	133	119	2	5	106	15	1023
HR TOTALS	1	2	3	4	5	6	7	8	9	10	11	12	TOTAL
PERIOD	SBRT	SBTH	SBLT	WBRT	WBTH	WBLT	NBRT	NBTH	NBLT	EBRT	EBTH	EBLT	
700-800	13	506	583	487	141	329	528	236	14	6	491	56	3390
715-815	24	599	625	482	179	358	550	268	17	12	543	56	3713
730-830	28	680	644	490	194	382	567	312	20	18	607	52	3994
745-845	32	700	668	483	212	424	549	354	22	20	642	58	4164
800-900	30	734	665	484	194	414	541	394	18	21	600	58	4153

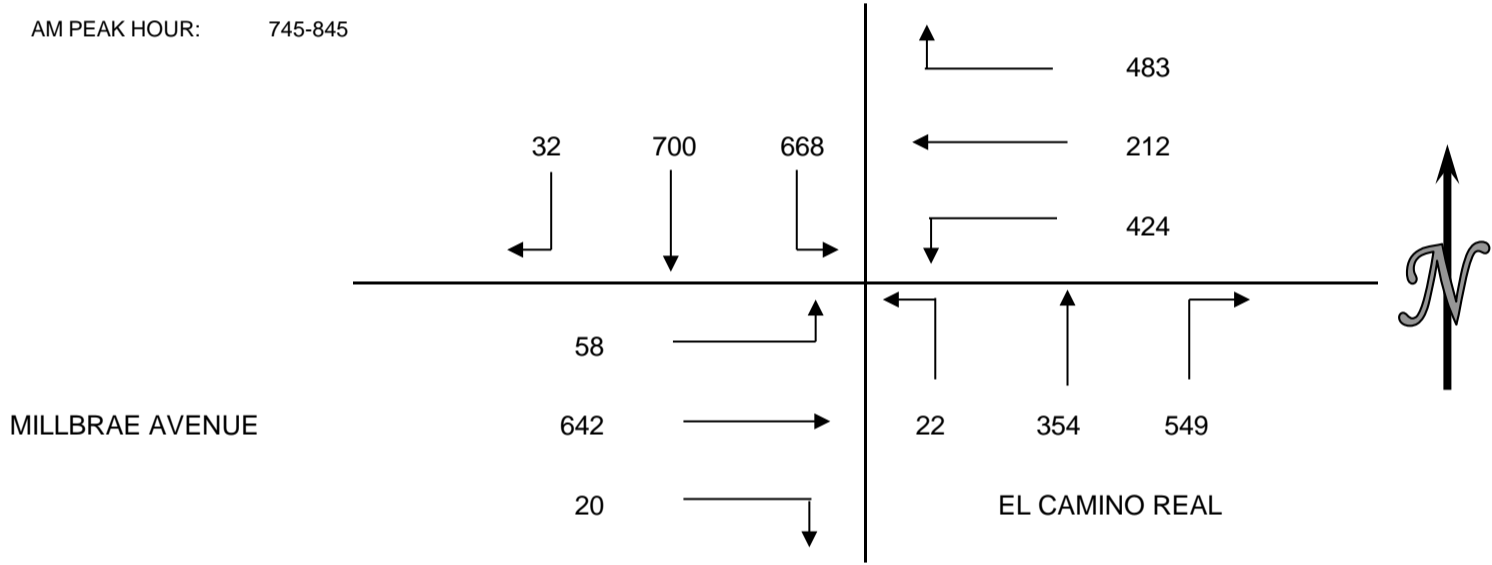

PEDESTRIAN COUNTS					
15 MIN COUNTS	NORTH LEG	EAST LEG	SOUTH LEG	WEST LEG	TOTAL
PERIOD					
700-715	18	4	4	1	27
715-730	12	1	5	2	20
730-745	20	0	2	2	24
745-800	18	0	0	0	18
800-815	19	1	2	1	23
815-830	25	1	0	0	26
830-845	11	2	1	3	17
845-900	14	0	2	1	17
HR TOTALS	NORTH LEG	EAST LEG	SOUTH LEG	WEST LEG	TOTAL
PERIOD					
700-800	68	5	11	5	89
715-815	69	2	9	5	85
730-830	82	2	4	3	91
745-845	73	4	3	4	84
800-900	69	4	5	5	83

BICYCLE COUNTS					
15 MIN COUNTS	NORTH LEG	EAST LEG	SOUTH LEG	WEST LEG	TOTAL
PERIOD					
700-715	0	2	0	0	2
715-730	1	0	0	1	2
730-745	0	0	0	0	0
745-800	1	0	0	0	1
800-815	5	0	0	1	6
815-830	0	0	0	1	1
830-845	0	0	0	3	3
845-900	2	1	1	1	5
HR TOTALS	NORTH LEG	EAST LEG	SOUTH LEG	WEST LEG	TOTAL
PERIOD					
700-800	2	2	0	1	5
715-815	7	0	0	2	9
730-830	6	0	0	2	8
745-845	6	0	0	5	11
800-900	7	1	1	6	15

Millbrae and El Camino

HR TOTALS	1	2	3	4	5	6	7	8	9	10	11	12	TOTAL
PERIOD	SBRT	SBTH	SBLT	WBRT	WBTH	WBLT	NBRT	NBTH	NBLT	EBRT	EBTH	EBLT	
700-800	13	506	583	487	141	329	528	236	14	6	491	56	3390
715-815	24	599	625	482	179	358	550	268	17	12	543	56	3713
730-830	28	680	644	490	194	382	567	312	20	18	607	52	3994
745-845	32	700	668	483	212	424	549	354	22	20	642	58	4164
800-900	30	734	665	484	194	414	541	394	18	21	600	58	4153

INTERSECTION CAR/PED/BIKE TRAFFIC COUNT RESULTS SUMMARY

CLIENT: FEHR & PEERS
 PROJECT: CALTRAIN TRAFFIC COUNTS
 DATE: WEDNESDAY MAY 22, 2013
 PERIOD: 4:00 PM TO 6:00 PM
 INTERSECTION: N/S EL CAMINO REAL
 E/W MILLBRAE AVENUE
 CITY: MILLBRAE

VEHICLE COUNTS													
15 MIN COUNTS	1	2	3	4	5	6	7	8	9	10	11	12	TOTAL
PERIOD	SBRT	SBTH	SBLT	WBRT	WBTH	WBLT	NBRT	NBTH	NBLT	EBRT	EBTH	EBLT	
400-415	10	174	150	175	108	131	115	197	10	8	57	31	1166
415-430	14	209	144	136	101	133	110	183	12	8	64	21	1135
430-445	15	183	137	174	120	166	92	139	6	3	69	23	1127
445-500	10	217	169	187	113	156	103	163	12	8	74	33	1245
500-515	17	229	156	180	130	136	90	172	13	7	81	30	1241
515-530	19	250	182	198	153	148	99	169	7	9	61	41	1336
530-545	14	238	128	199	139	156	80	185	8	12	64	24	1247
545-600	13	196	133	197	186	162	99	139	9	7	66	37	1244
HOURLY TOTALS	1	2	3	4	5	6	7	8	9	10	11	12	TOTAL
PERIOD	SBRT	SBTH	SBLT	WBRT	WBTH	WBLT	NBRT	NBTH	NBLT	EBRT	EBTH	EBLT	
400-500	49	783	600	672	442	586	420	682	40	27	264	108	4673
415-515	56	838	606	677	464	591	395	657	43	26	288	107	4748
430-530	61	879	644	739	516	606	384	643	38	27	285	127	4949
445-545	60	934	635	764	535	596	372	689	40	36	280	128	5069
500-600	63	913	599	774	608	602	368	665	37	35	272	132	5068

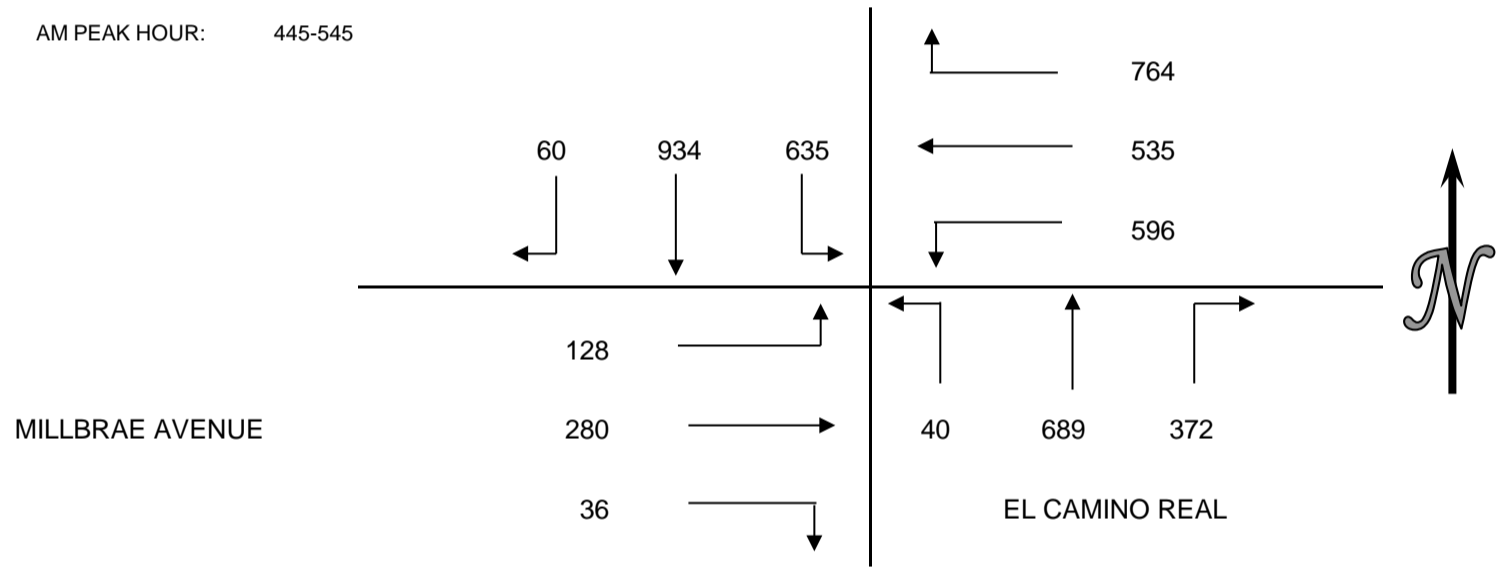

PEDESTRIAN COUNTS					
15 MIN COUNTS	NORTH LEG	EAST LEG	SOUTH LEG	WEST LEG	TOTAL
PERIOD					
400-415	5	0	0	2	7
415-430	7	5	2	3	17
430-445	8	0	7	1	16
445-500	18	0	5	7	30
500-515	15	2	2	4	23
515-530	20	0	0	6	26
530-545	15	2	1	2	20
545-600	35	2	2	9	48
HOURLY TOTALS	NORTH LEG	EAST LEG	SOUTH LEG	WEST LEG	TOTAL
PERIOD					
400-500	38	5	14	13	70
415-515	48	7	16	15	86
430-530	61	2	14	18	95
445-545	68	4	8	19	99
500-600	85	6	5	21	117

BICYCLE COUNTS					
15 MIN COUNTS	NORTH LEG	EAST LEG	SOUTH LEG	WEST LEG	TOTAL
PERIOD					
400-415	2	0	0	0	2
415-430	1	0	0	0	1
430-445	0	1	0	2	3
445-500	1	0	1	2	4
500-515	0	1	1	0	2
515-530	1	0	0	1	2
530-545	2	0	0	0	2
545-600	1	1	0	0	2
HOURLY TOTALS	NORTH LEG	EAST LEG	SOUTH LEG	WEST LEG	TOTAL
PERIOD					
400-500	4	1	1	4	10
415-515	2	2	2	4	10
430-530	2	2	2	5	11
445-545	4	1	2	3	10
500-600	4	2	1	1	8

Millbrae and El Camino

HOURLY TOTALS	1	2	3	4	5	6	7	8	9	10	11	12	TOTAL
PERIOD	SBRT	SBTH	SBLT	WBRT	WBTH	WBLT	NBRT	NBTH	NBLT	EBRT	EBTH	EBLT	
400-500	49	783	600	672	442	586	420	682	40	27	264	108	4673
415-515	56	838	606	677	464	591	395	657	43	26	288	107	4748
430-530	61	879	644	739	516	606	384	643	38	27	285	127	4949
445-545	60	934	635	764	535	596	372	689	40	36	280	128	5069
500-600	63	913	599	774	608	602	368	665	37	35	272	132	5068

INTERSECTION CAR/PED/BIKE TRAFFIC COUNT RESULTS SUMMARY

CLIENT: FEHR & PEERS
 PROJECT: CALTRAIN TRAFFIC COUNTS
 DATE: WEDNESDAY MAY 22, 2013
 PERIOD: 7:00 AM TO 9:00 AM
 INTERSECTION: N/S ROLLINS AVENUE
 E/W MILLBRAE AVENUE
 CITY: MILLBRAE

VEHICLE COUNTS													
15 MIN COUNTS	1	2	3	4	5	6	7	8	9	10	11	12	TOTAL
PERIOD	SBRT	SBTH	SBLT	WBRT	WBTH	WBLT	NBRT	NBTH	NBLT	EBRT	EBTH	EBLT	TOTAL
700-715	7	3	30	148	165	105	48	27	27	25	217	62	864
715-730	1	2	32	127	210	96	57	25	19	42	281	69	961
730-745	11	4	28	121	217	100	55	27	23	45	299	86	1016
745-800	1	5	35	119	246	118	65	28	20	66	323	80	1106
800-815	5	6	34	112	222	109	63	28	22	60	307	78	1046
815-830	3	1	25	106	247	102	47	29	22	74	359	70	1085
830-845	6	5	37	76	229	107	71	28	42	64	297	48	1010
845-900	6	2	14	51	258	86	66	20	33	50	314	64	964
HOURLY TOTALS	1	2	3	4	5	6	7	8	9	10	11	12	TOTAL
PERIOD	SBRT	SBTH	SBLT	WBRT	WBTH	WBLT	NBRT	NBTH	NBLT	EBRT	EBTH	EBLT	TOTAL
700-800	20	14	125	515	838	419	225	107	89	178	1120	297	3947
715-815	18	17	129	479	895	423	240	108	84	213	1210	313	4129
730-830	20	16	122	458	932	429	230	112	87	245	1288	314	4253
745-845	15	17	131	413	944	436	246	113	106	264	1286	276	4247
800-900	20	14	110	345	956	404	247	105	119	248	1277	260	4105

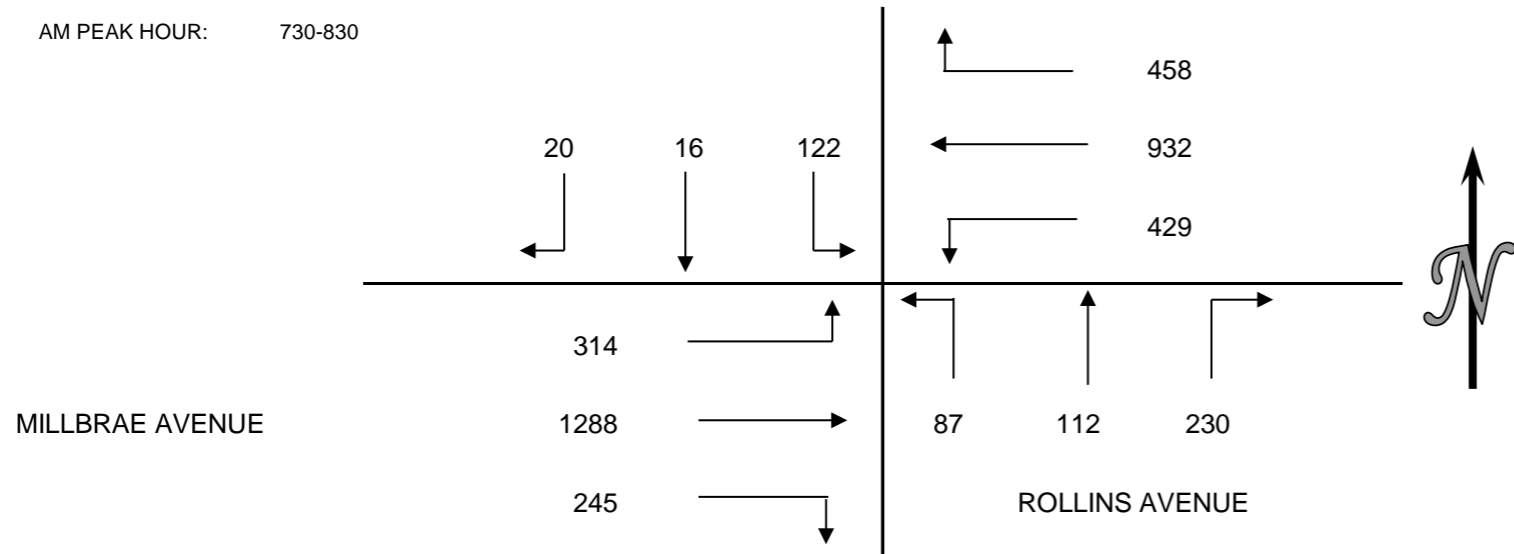

PEDESTRIAN COUNTS					
15 MIN COUNTS	NORTH LEG	EAST LEG	SOUTH LEG	WEST LEG	TOTAL
PERIOD	LEG	LEG	LEG	LEG	TOTAL
700-715	0	1	4	12	17
715-730	0	0	0	10	10
730-745	0	0	2	2	4
745-800	1	1	3	3	8
800-815	0	0	5	3	8
815-830	0	0	4	0	4
830-845	0	0	1	4	5
845-900	0	0	10	10	20
HOURLY TOTALS	NORTH LEG	EAST LEG	SOUTH LEG	WEST LEG	TOTAL
PERIOD	LEG	LEG	LEG	LEG	TOTAL
700-800	1	2	9	27	39
715-815	1	1	10	18	30
730-830	1	1	14	8	24
745-845	1	1	13	10	25
800-900	0	0	20	17	37

BICYCLE COUNTS					
15 MIN COUNTS	NORTH LEG	EAST LEG	SOUTH LEG	WEST LEG	TOTAL
PERIOD	LEG	LEG	LEG	LEG	TOTAL
700-715	0	0	1	1	2
715-730	0	0	0	4	4
730-745	0	0	0	0	0
745-800	0	0	2	4	6
800-815	0	1	1	1	3
815-830	0	0	0	1	1
830-845	0	0	0	1	1
845-900	1	1	2	3	7
HOURLY TOTALS	NORTH LEG	EAST LEG	SOUTH LEG	WEST LEG	TOTAL
PERIOD	LEG	LEG	LEG	LEG	TOTAL
700-800	0	0	3	9	12
715-815	0	1	3	9	13
730-830	0	1	3	6	10
745-845	0	1	3	7	11
800-900	1	2	3	6	12

Millbrae and El Camino

HOURLY TOTALS	1	2	3	4	5	6	7	8	9	10	11	12	TOTAL
PERIOD	SBRT	SBTH	SBLT	WBRT	WBTH	WBLT	NBRT	NBTH	NBLT	EBRT	EBTH	EBLT	TOTAL
700-800	13	506	583	487	141	329	528	236	14	6	491	56	3390
715-815	24	599	625	482	179	358	550	268	17	12	543	56	3713
730-830	28	680	644	490	194	382	567	312	20	18	607	52	3994
745-845	32	700	668	483	212	424	549	354	22	20	642	58	4164
800-900	30	734	665	484	194	414	541	394	18	21	600	58	4153

Millbrae and Rollins

HOURLY TOTALS	1	2	3	4	5	6	7	8	9	10	11	12	TOTAL
PERIOD	SBRT	SBTH	SBLT	WBRT	WBTH	WBLT	NBRT	NBTH	NBLT	EBRT	EBTH	EBLT	TOTAL
700-800	20	14	125	515	838	419	225	107	89	178	1120	297	3947
715-815	18	17	129	479	895	423	240	108	84	213	1210	313	4129
730-830	20	16	122	458	932	429	230	112	87	245	1288	314	4253
745-845	15	17	131	413	944	436	246	113	106	264	1286	276	4247
800-900	20	14	110	345	956	404	247	105	119	248	1277	260	4105

INTERSECTION CAR/PED/BIKE TRAFFIC COUNT RESULTS SUMMARY

CLIENT: FEHR & PEERS
 PROJECT: CALTRAIN TRAFFIC COUNTS
 DATE: WEDNESDAY MAY 22, 2013
 PERIOD: 4:00 PM TO 6:00 PM
 INTERSECTION: N/S ROLLINS AVENUE
 E/W MILLBRAE AVENUE
 CITY: MILLBRAE

VEHICLE COUNTS													
15 MIN COUNTS	1	2	3	4	5	6	7	8	9	10	11	12	TOTAL
PERIOD	SBRT	SBTH	SBLT	WBRT	WBTH	WBLT	NBRT	NBTH	NBLT	EBRT	EBTH	EBLT	
400-415	11	6	51	31	382	114	97	6	55	54	266	9	1082
415-430	16	9	59	27	340	81	105	14	78	40	275	17	1061
430-445	13	8	77	32	378	90	127	8	97	41	273	14	1158
445-500	22	16	85	41	353	97	109	10	72	46	263	24	1138
500-515	26	5	77	41	338	87	134	17	91	42	256	17	1131
515-530	38	18	97	41	331	85	101	10	79	34	284	17	1135
530-545	24	5	81	49	367	89	110	13	81	30	240	23	1112
545-600	39	19	116	41	374	92	101	13	67	32	269	22	1185
HOURLY TOTALS	1	2	3	4	5	6	7	8	9	10	11	12	TOTAL
PERIOD	SBRT	SBTH	SBLT	WBRT	WBTH	WBLT	NBRT	NBTH	NBLT	EBRT	EBTH	EBLT	
400-500	62	39	272	131	1453	382	438	38	302	181	1077	64	4439
415-515	77	38	298	141	1409	355	475	49	338	169	1067	72	4488
430-530	99	47	336	155	1400	359	471	45	339	163	1076	72	4562
445-545	110	44	340	172	1389	358	454	50	323	152	1043	81	4516
500-600	127	47	371	172	1410	353	446	53	318	138	1049	79	4563

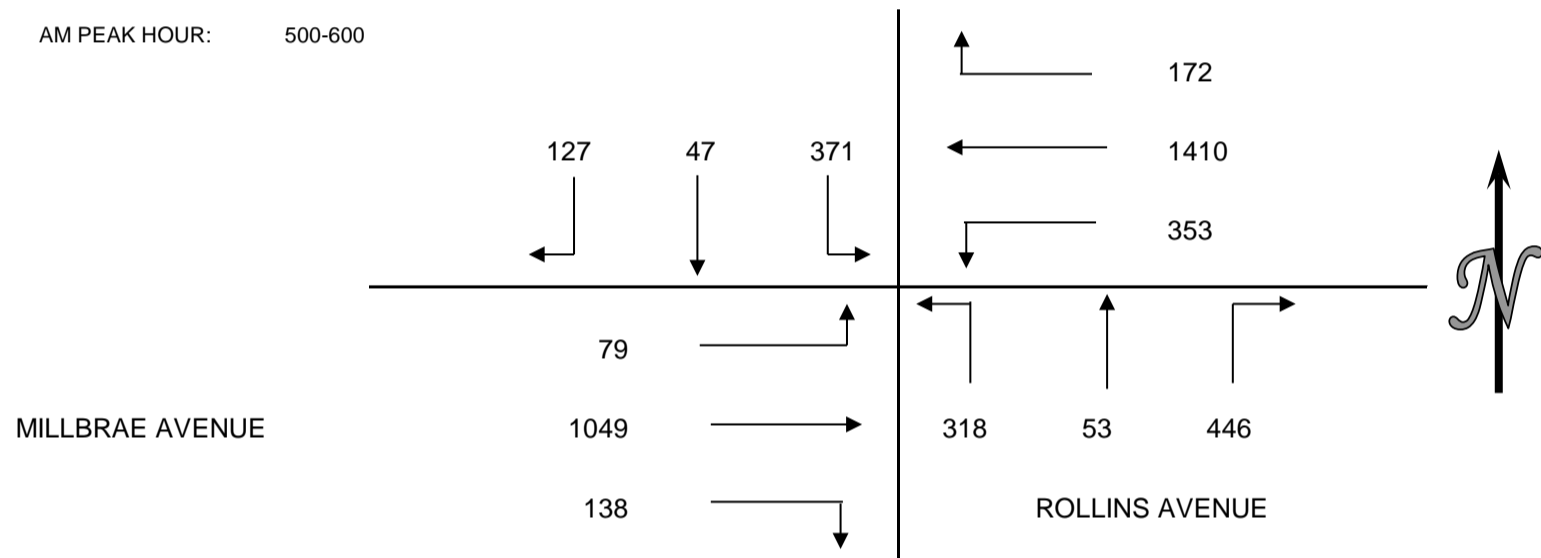

PEDESTRIAN COUNTS					
15 MIN COUNTS	NORTH LEG	EAST LEG	SOUTH LEG	WEST LEG	TOTAL
PERIOD					
400-415	0	0	5	7	12
415-430	0	0	3	3	6
430-445	0	0	4	5	9
445-500	0	0	2	3	5
500-515	1	0	6	1	8
515-530	0	0	0	10	10
530-545	0	0	1	6	7
545-600	1	0	7	8	16
HOURLY TOTALS	NORTH LEG	EAST LEG	SOUTH LEG	WEST LEG	TOTAL
PERIOD					
400-500	0	0	14	18	32
415-515	1	0	15	12	28
430-530	1	0	12	19	32
445-545	1	0	9	20	30
500-600	2	0	14	25	41

BICYCLE COUNTS					
15 MIN COUNTS	NORTH LEG	EAST LEG	SOUTH LEG	WEST LEG	TOTAL
PERIOD					
400-415	0	1	0	0	1
415-430	2	0	0	1	3
430-445	1	0	1	0	2
445-500	1	0	0	0	1
500-515	0	0	1	0	1
515-530	2	0	1	0	3
530-545	1	0	0	1	2
545-600	0	1	0	1	2
HOURLY TOTALS	NORTH LEG	EAST LEG	SOUTH LEG	WEST LEG	TOTAL
PERIOD					
400-500	4	1	1	1	7
415-515	4	0	2	1	7
430-530	4	0	3	0	7
445-545	4	0	2	1	7
500-600	3	1	2	2	8

Millbrae and El Camino

HOURLY TOTALS	1	2	3	4	5	6	7	8	9	10	11	12	TOTAL
PERIOD	SBRT	SBTH	SBLT	WBRT	WBTH	WBLT	NBRT	NBTH	NBLT	EBRT	EBTH	EBLT	
400-500	49	783	600	672	442	586	420	682	40	27	264	108	4673
415-515	56	838	606	677	464	591	395	657	43	26	288	107	4748
430-530	61	879	644	739	516	606	384	643	38	27	285	127	4949
445-545	60	934	635	764	535	596	372	689	40	36	280	128	5069
500-600	63	913	599	774	608	602	368	665	37	35	272	132	5068

Millbrae and Rollins

HOURLY TOTALS	1	2	3	4	5	6	7	8	9	10	11	12	TOTAL
PERIOD	SBRT	SBTH	SBLT	WBRT	WBTH	WBLT	NBRT	NBTH	NBLT	EBRT	EBTH	EBLT	
400-500	62	39	272	131	1453	382	438	38	302	181	1077	64	4439
415-515	77	38	298	141	1409	355	475	49	338	169	1067	72	4488
430-530	99	47	336	155	1400	359	471	45	339	163	1076	72	4562
445-545	110	44	340	172	1389	358	454	50	323	152	1043	81	4516
500-600	127	47	371	172	1410	353	446	53	318	138	1049	79	4563

Traffic Data Service

Campbell, CA
 (408) 377-2988
 tdsbay@cs.com

File Name : 13AM FINAL
 Site Code : 00000013
 Start Date : 5/22/2013
 Page No : 1

Groups Printed- Vehicles

Start Time	PERRY ST Southbound					BROADWAY Westbound					CALIFORNIA ST Northbound					BROADWAY Eastbound					Int. Total
	Right	Thru	Left	Peds	App. Total	Right	Thru	Left	Peds	App. Total	Right	Thru	Left	Peds	App. Total	Right	Thru	Left	Peds	App. Total	
07:00 AM	2	3	1	8	14	3	13	9	3	28	3	5	1	17	26	7	26	7	16	56	124
07:15 AM	0	3	1	5	9	3	16	10	0	29	7	4	0	22	33	11	44	2	25	82	153
07:30 AM	7	3	0	4	14	2	23	8	1	34	7	4	0	13	24	4	45	3	16	68	140
07:45 AM	1	4	2	15	22	5	35	17	3	60	6	2	1	18	27	7	57	0	24	88	197
Total	10	13	4	32	59	13	87	44	7	151	23	15	2	70	110	29	172	12	81	294	614
08:00 AM	1	1	4	10	16	3	16	18	4	41	16	4	1	49	70	13	91	9	40	153	280
08:15 AM	3	4	5	7	19	8	41	10	4	63	12	6	1	54	73	12	79	5	38	134	289
08:30 AM	4	3	5	28	40	6	36	7	2	51	18	5	1	34	58	8	79	9	44	140	289
08:45 AM	2	4	5	14	25	4	26	7	1	38	10	2	1	22	35	14	67	4	24	109	207
Total	10	12	19	59	100	21	119	42	11	193	56	17	4	159	236	47	316	27	146	536	1065
Grand Total	20	25	23	91	159	34	206	86	18	344	79	32	6	229	346	76	488	39	227	830	1679
Apprch %	12.6	15.7	14.5	57.2		9.9	59.9	25	5.2		22.8	9.2	1.7	66.2		9.2	58.8	4.7	27.3		
Total %	1.2	1.5	1.4	5.4	9.5	2	12.3	5.1	1.1	20.5	4.7	1.9	0.4	13.6	20.6	4.5	29.1	2.3	13.5	49.4	

Start Time	PERRY ST Southbound				BROADWAY Westbound				CALIFORNIA ST Northbound				BROADWAY Eastbound				Int. Total
	Right	Thru	Left	App. Total	Right	Thru	Left	App. Total	Right	Thru	Left	App. Total	Right	Thru	Left	App. Total	
08:00 AM	1	1	4	6	3	16	18	37	16	4	1	21	13	91	9	113	177
08:15 AM	3	4	5	12	8	41	10	59	12	6	1	19	12	79	5	96	186
08:30 AM	4	3	5	12	6	36	7	49	18	5	1	24	8	79	9	96	181
08:45 AM	2	4	5	11	4	26	7	37	10	2	1	13	14	67	4	85	146
Total Volume	10	12	19	41	21	119	42	182	56	17	4	77	47	316	27	390	690
% App. Total	24.4	29.3	46.3		11.5	65.4	23.1		72.7	22.1	5.2		12.1	81	6.9		
PHF	.625	.750	.950	.854	.656	.726	.583	.771	.778	.708	1.00	.802	.839	.868	.750	.863	.927

Peak Hour Analysis From 07:00 AM to 08:45 AM - Peak 1 of 1

Peak Hour for Entire Intersection Begins at 08:00 AM

Traffic Data Service

Campbell, CA
(408) 377-2988
tdsbay@cs.com

File Name : 13AM FINAL
Site Code : 00000013
Start Date : 5/22/2013
Page No : 2

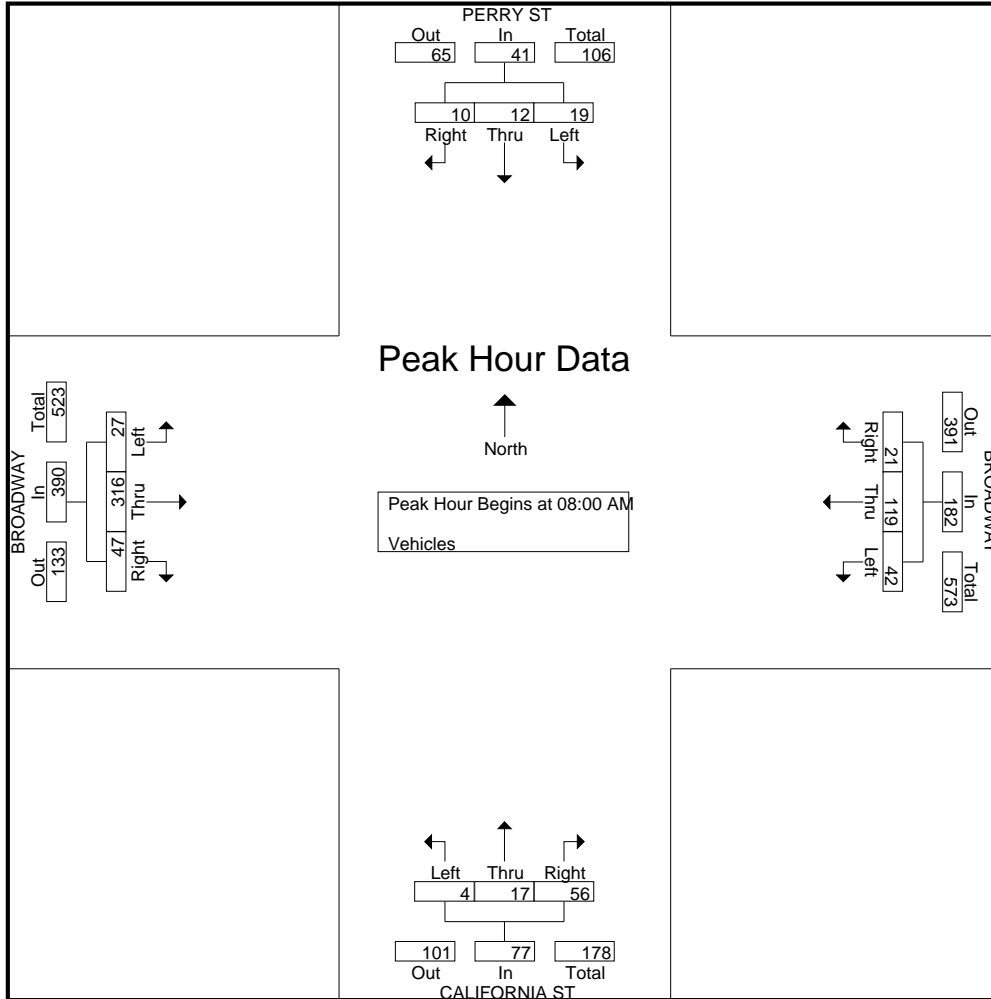

Traffic Data Service

Campbell, CA
 (408) 377-2988
 tdsbay@cs.com

File Name : 13AM FINAL
 Site Code : 00000013
 Start Date : 5/22/2013
 Page No : 1

Groups Printed- Bikes

Start Time	PERRY ST Southbound					BROADWAY Westbound					CALIFORNIA ST Northbound					BROADWAY Eastbound					Int. Total
	Right	Thru	Left	Peds	App. Total	Right	Thru	Left	Peds	App. Total	Right	Thru	Left	Peds	App. Total	Right	Thru	Left	Peds	App. Total	
07:00 AM	0	0	0	0	0	1	0	0	0	1	1	0	0	0	1	0	3	1	0	4	6
07:15 AM	0	0	2	0	2	1	0	0	0	1	0	0	0	0	0	0	1	0	0	1	4
07:30 AM	0	0	1	0	1	0	0	0	0	0	1	0	0	0	1	0	4	0	0	4	6
07:45 AM	0	0	1	0	1	0	1	1	0	2	0	1	0	0	1	0	1	0	0	1	5
Total	0	0	4	0	4	2	1	1	0	4	2	1	0	0	3	0	9	1	0	10	21
08:00 AM	0	1	0	0	1	1	0	0	0	1	0	0	0	0	0	0	2	0	0	2	4
08:15 AM	0	0	0	0	0	0	1	0	0	1	0	0	0	0	0	0	3	0	0	3	4
08:30 AM	0	0	3	0	3	0	0	0	0	0	0	0	0	0	0	0	4	0	0	4	7
08:45 AM	0	0	0	0	0	0	0	0	0	0	0	0	0	0	0	0	1	0	0	1	1
Total	0	1	3	0	4	1	1	0	0	2	0	0	0	0	0	0	10	0	0	10	16
Grand Total	0	1	7	0	8	3	2	1	0	6	2	1	0	0	3	0	19	1	0	20	37
Apprch %	0	12.5	87.5	0		50	33.3	16.7	0		66.7	33.3	0	0		0	95	5	0		
Total %	0	2.7	18.9	0	21.6	8.1	5.4	2.7	0	16.2	5.4	2.7	0	0	8.1	0	51.4	2.7	0	54.1	

Start Time	PERRY ST Southbound				BROADWAY Westbound				CALIFORNIA ST Northbound				BROADWAY Eastbound				Int. Total
	Right	Thru	Left	App. Total	Right	Thru	Left	App. Total	Right	Thru	Left	App. Total	Right	Thru	Left	App. Total	
07:00 AM	0	0	0	0	1	0	0	1	1	0	0	1	0	3	1	4	6
07:15 AM	0	0	2	2	1	0	0	1	0	0	0	0	0	1	0	1	4
07:30 AM	0	0	1	1	0	0	0	0	1	0	0	1	0	4	0	4	6
07:45 AM	0	0	1	1	0	1	1	2	0	1	0	1	0	1	0	1	5
Total Volume	0	0	4	4	2	1	1	4	2	1	0	3	0	9	1	10	21
% App. Total	0	0	100		50	25	25		66.7	33.3	0		0	90	10		
PHF	.000	.000	.500	.500	.500	.250	.250	.500	.500	.250	.000	.750	.000	.563	.250	.625	.875

Peak Hour Analysis From 07:00 AM to 08:45 AM - Peak 1 of 1

Peak Hour for Entire Intersection Begins at 07:00 AM

Traffic Data Service

Campbell, CA
(408) 377-2988
tdsbay@cs.com

File Name : 13AM FINAL
Site Code : 00000013
Start Date : 5/22/2013
Page No : 2

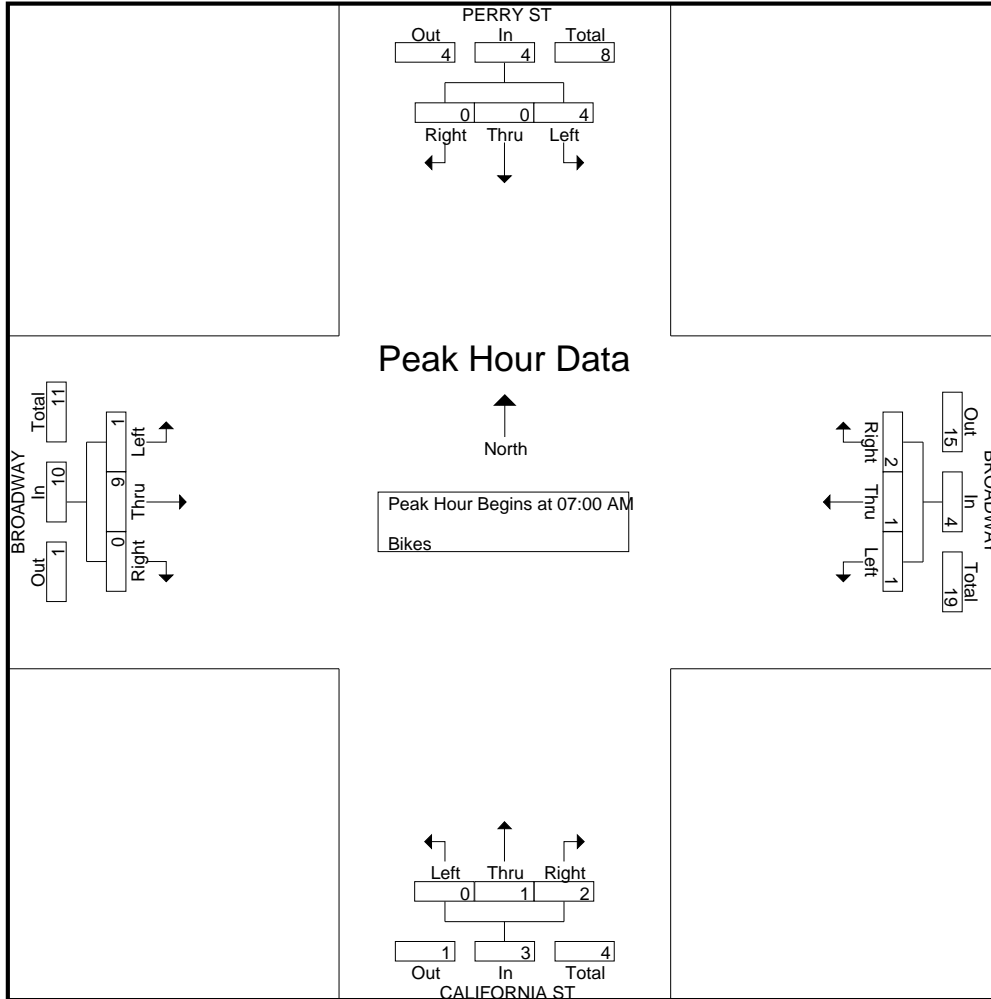

Traffic Data Service

Campbell, CA
 (408) 377-2988
 tdsbay@cs.com

File Name : 13PM FINAL
 Site Code : 00000013
 Start Date : 5/22/2013
 Page No : 1

Groups Printed- Vehicles

Start Time	PERRY ST Southbound					BROADWAY Westbound					CALIFORNIA ST Northbound					BROADWAY Eastbound					Int. Total
	Right	Thru	Left	Peds	App. Total	Right	Thru	Left	Peds	App. Total	Right	Thru	Left	Peds	App. Total	Right	Thru	Left	Peds	App. Total	
04:00 PM	8	4	6	11	29	4	52	13	3	72	15	5	3	35	58	8	58	11	24	101	260
04:15 PM	10	2	4	2	18	3	75	13	5	96	11	6	4	21	42	9	48	5	19	81	237
04:30 PM	16	8	3	6	33	6	74	21	1	102	18	2	3	23	46	9	35	9	21	74	255
04:45 PM	10	5	8	5	28	15	74	22	3	114	15	6	4	33	58	15	38	6	40	99	299
Total	44	19	21	24	108	28	275	69	12	384	59	19	14	112	204	41	179	31	104	355	1051
05:00 PM	13	5	5	10	33	8	93	25	3	129	17	6	2	36	61	6	38	2	32	78	301
05:15 PM	12	4	5	6	27	7	78	28	0	113	15	3	5	44	67	11	32	9	36	88	295
05:30 PM	20	4	6	11	41	16	71	21	7	115	14	6	2	47	69	12	44	5	32	93	318
05:45 PM	9	15	5	10	39	8	69	20	3	100	13	8	3	18	42	15	42	12	20	89	270
Total	54	28	21	37	140	39	311	94	13	457	59	23	12	145	239	44	156	28	120	348	1184
Grand Total	98	47	42	61	248	67	586	163	25	841	118	42	26	257	443	85	335	59	224	703	2235
Apprch %	39.5	19	16.9	24.6		8	69.7	19.4	3		26.6	9.5	5.9	58		12.1	47.7	8.4	31.9		
Total %	4.4	2.1	1.9	2.7	11.1	3	26.2	7.3	1.1	37.6	5.3	1.9	1.2	11.5	19.8	3.8	15	2.6	10	31.5	

Start Time	PERRY ST Southbound				BROADWAY Westbound				CALIFORNIA ST Northbound				BROADWAY Eastbound				Int. Total
	Right	Thru	Left	App. Total	Right	Thru	Left	App. Total	Right	Thru	Left	App. Total	Right	Thru	Left	App. Total	
Peak Hour Analysis From 04:00 PM to 05:45 PM - Peak 1 of 1																	
Peak Hour for Entire Intersection Begins at 05:00 PM																	
05:00 PM	13	5	5	23	8	93	25	126	17	6	2	25	6	38	2	46	220
05:15 PM	12	4	5	21	7	78	28	113	15	3	5	23	11	32	9	52	209
05:30 PM	20	4	6	30	16	71	21	108	14	6	2	22	12	44	5	61	221
05:45 PM	9	15	5	29	8	69	20	97	13	8	3	24	15	42	12	69	219
Total Volume	54	28	21	103	39	311	94	444	59	23	12	94	44	156	28	228	869
% App. Total	52.4	27.2	20.4		8.8	70	21.2		62.8	24.5	12.8		19.3	68.4	12.3		
PHF	.675	.467	.875	.858	.609	.836	.839	.881	.868	.719	.600	.940	.733	.886	.583	.826	.983

Traffic Data Service

Campbell, CA
(408) 377-2988
tdsbay@cs.com

File Name : 13PM FINAL
Site Code : 00000013
Start Date : 5/22/2013
Page No : 2

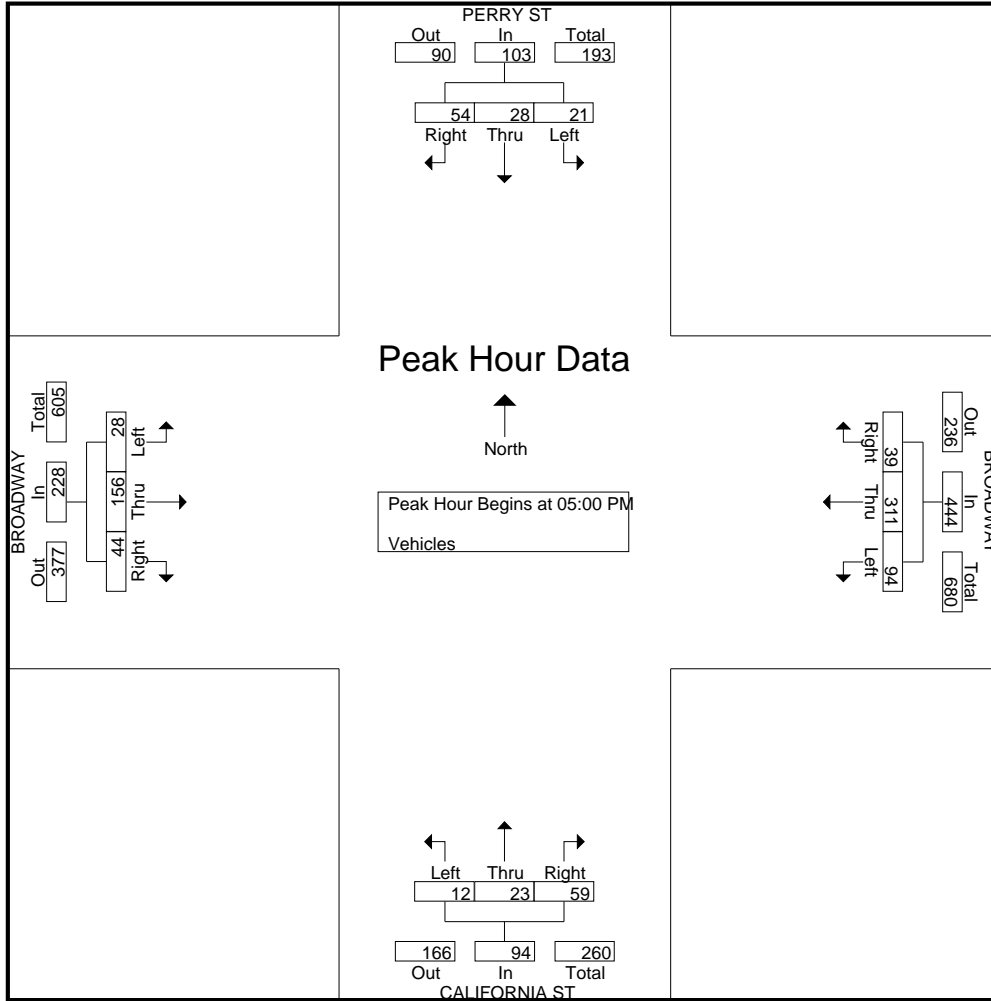

Traffic Data Service

Campbell, CA
 (408) 377-2988
 tdsbay@cs.com

File Name : 13PM FINAL
 Site Code : 00000013
 Start Date : 5/22/2013
 Page No : 1

Groups Printed- Bikes

Start Time	PERRY ST Southbound					BROADWAY Westbound					CALIFORNIA ST Northbound					BROADWAY Eastbound					Int. Total
	Right	Thru	Left	Peds	App. Total	Right	Thru	Left	Peds	App. Total	Right	Thru	Left	Peds	App. Total	Right	Thru	Left	Peds	App. Total	
04:00 PM	0	0	0	0	0	0	1	0	0	1	0	1	0	0	1	1	0	0	0	1	3
04:15 PM	0	0	0	0	0	0	0	0	1	1	0	0	1	0	1	0	2	0	0	2	4
04:30 PM	0	0	0	0	0	0	1	2	0	3	0	0	0	0	0	2	0	0	0	2	5
04:45 PM	0	1	1	0	2	2	1	0	0	3	1	0	0	0	1	1	3	0	0	4	10
Total	0	1	1	0	2	2	3	2	1	8	1	1	1	0	3	4	5	0	0	9	22
05:00 PM	0	0	0	0	0	0	2	0	0	2	0	0	0	0	0	0	1	0	0	1	3
05:15 PM	0	0	0	0	0	1	1	1	0	3	0	0	0	0	0	0	0	0	0	0	3
05:30 PM	0	0	0	0	0	1	4	2	0	7	0	1	0	0	1	0	0	0	0	0	8
05:45 PM	0	0	0	0	0	2	3	0	0	5	0	0	0	0	0	0	1	0	0	1	6
Total	0	0	0	0	0	4	10	3	0	17	0	1	0	0	1	0	2	0	0	2	20
Grand Total	0	1	1	0	2	6	13	5	1	25	1	2	1	0	4	4	7	0	0	11	42
Apprch %	0	50	50	0		24	52	20	4		25	50	25	0		36.4	63.6	0	0		
Total %	0	2.4	2.4	0	4.8	14.3	31	11.9	2.4	59.5	2.4	4.8	2.4	0	9.5	9.5	16.7	0	0	26.2	

Start Time	PERRY ST Southbound				BROADWAY Westbound				CALIFORNIA ST Northbound				BROADWAY Eastbound				Int. Total
	Right	Thru	Left	App. Total	Right	Thru	Left	App. Total	Right	Thru	Left	App. Total	Right	Thru	Left	App. Total	
04:45 PM	0	1	1	2	2	1	0	3	1	0	0	1	1	3	0	4	10
05:00 PM	0	0	0	0	0	2	0	2	0	0	0	0	0	1	0	1	3
05:15 PM	0	0	0	0	1	1	1	3	0	0	0	0	0	0	0	0	3
05:30 PM	0	0	0	0	1	4	2	7	0	1	0	1	0	0	0	0	8
Total Volume	0	1	1	2	4	8	3	15	1	1	0	2	1	4	0	5	24
% App. Total	0	50	50		26.7	53.3	20		50	50	0		20	80	0		
PHF	.000	.250	.250	.250	.500	.500	.375	.536	.250	.250	.000	.500	.250	.333	.000	.313	.600

Peak Hour Analysis From 04:00 PM to 05:45 PM - Peak 1 of 1

Peak Hour for Entire Intersection Begins at 04:45 PM

Traffic Data Service

Campbell, CA

(408) 377-2988

tdsbay@cs.com

File Name : 13PM FINAL

Site Code : 00000013

Start Date : 5/22/2013

Page No : 2

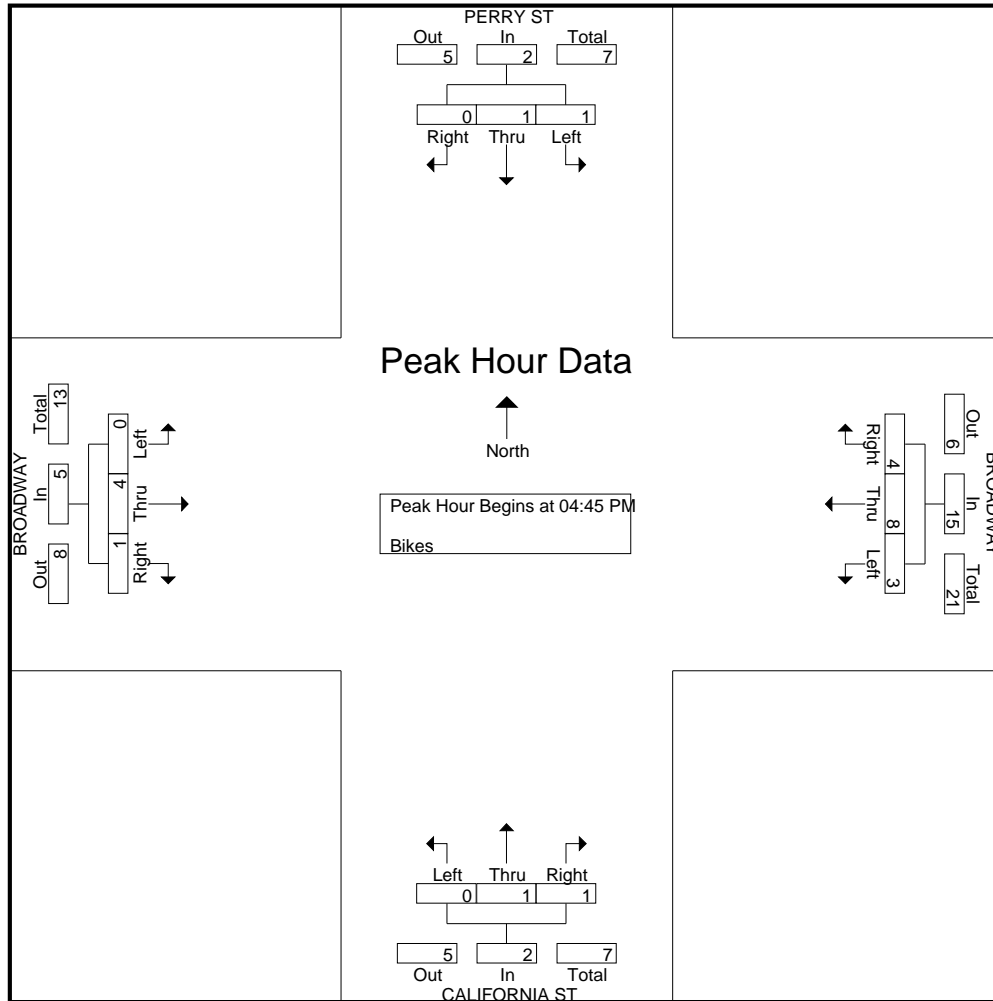

All Traffic Data

(916) 771-8700

City of Burlingame

File Name : 12-7153-003 Carolan-Broadway

Site Code : 00000000

Start Date : 4/18/2012

Page No : 1

Groups Printed- Unshifted

Start Time	Driveway Southbound				Broadway Avenue Westbound				Carolan Avenue Northbound				Broadway Avenue Eastbound				Int. Total
	Left	Thru	Right	App. Total	Left	Thru	Right	App. Total	Left	Thru	Right	App. Total	Left	Thru	Right	App. Total	
07:00	0	0	0	0	14	109	0	123	8	0	68	76	1	189	5	195	394
07:15	0	0	0	0	17	147	1	165	4	0	93	97	0	238	12	250	512
07:30	0	0	0	0	17	169	0	186	6	0	94	100	1	248	10	259	545
07:45	0	0	0	0	17	167	0	184	10	0	117	127	0	290	9	299	610
Total	0	0	0	0	65	592	1	658	28	0	372	400	2	965	36	1003	2061
08:00	0	0	0	0	18	144	0	162	22	0	101	123	0	297	4	301	586
08:15	0	0	0	0	33	182	0	215	21	0	100	121	0	281	30	311	647
08:30	0	0	0	0	24	161	0	185	21	0	97	118	1	278	62	341	644
08:45	0	0	0	0	28	189	0	217	33	0	99	132	0	288	64	352	701
Total	0	0	0	0	103	676	0	779	97	0	397	494	1	1144	160	1305	2578
16:00	0	0	0	0	33	243	0	276	13	0	72	85	0	207	20	227	588
16:15	0	0	0	0	35	239	0	274	6	0	75	81	0	223	27	250	605
16:30	0	0	0	0	40	237	0	277	20	0	75	95	0	214	24	238	610
16:45	0	0	0	0	36	243	0	279	20	0	79	99	0	219	29	248	626
Total	0	0	0	0	144	962	0	1106	59	0	301	360	0	863	100	963	2429
17:00	0	0	0	0	49	275	0	324	30	0	84	114	0	230	28	258	696
17:15	0	0	0	0	46	283	1	330	14	0	77	91	1	245	32	278	699
17:30	0	0	0	0	53	272	0	325	17	0	76	93	0	230	19	249	667
17:45	0	0	0	0	47	271	0	318	25	1	74	100	0	210	25	235	653
Total	0	0	0	0	195	1101	1	1297	86	1	311	398	1	915	104	1020	2715
Grand Total	0	0	0	0	507	3331	2	3840	270	1	1381	1652	4	3887	400	4291	9783
Apprch %	0	0	0		13.2	86.7	0.1		16.3	0.1	83.6		0.1	90.6	9.3		
Total %	0	0	0		5.2	34	0	39.3	2.8	0	14.1	16.9	0	39.7	4.1	43.9	

Start Time	Driveway Southbound				Broadway Avenue Westbound				Carolan Avenue Northbound				Broadway Avenue Eastbound				Int. Total
	Left	Thru	Right	App. Total	Left	Thru	Right	App. Total	Left	Thru	Right	App. Total	Left	Thru	Right	App. Total	
Peak Hour Analysis From 07:00 to 08:45 - Peak 1 of 1																	
Peak Hour for Entire Intersection Begins at 08:00																	
08:00	0	0	0	0	18	144	0	162	22	0	101	123	0	297	4	301	586
08:15	0	0	0	0	33	182	0	215	21	0	100	121	0	281	30	311	647
08:30	0	0	0	0	24	161	0	185	21	0	97	118	1	278	62	341	644
08:45	0	0	0	0	28	189	0	217	33	0	99	132	0	288	64	352	701
Total Volume	0	0	0	0	103	676	0	779	97	0	397	494	1	1144	160	1305	2578
% App. Total	0	0	0		13.2	86.8	0		19.6	0	80.4		0.1	87.7	12.3		

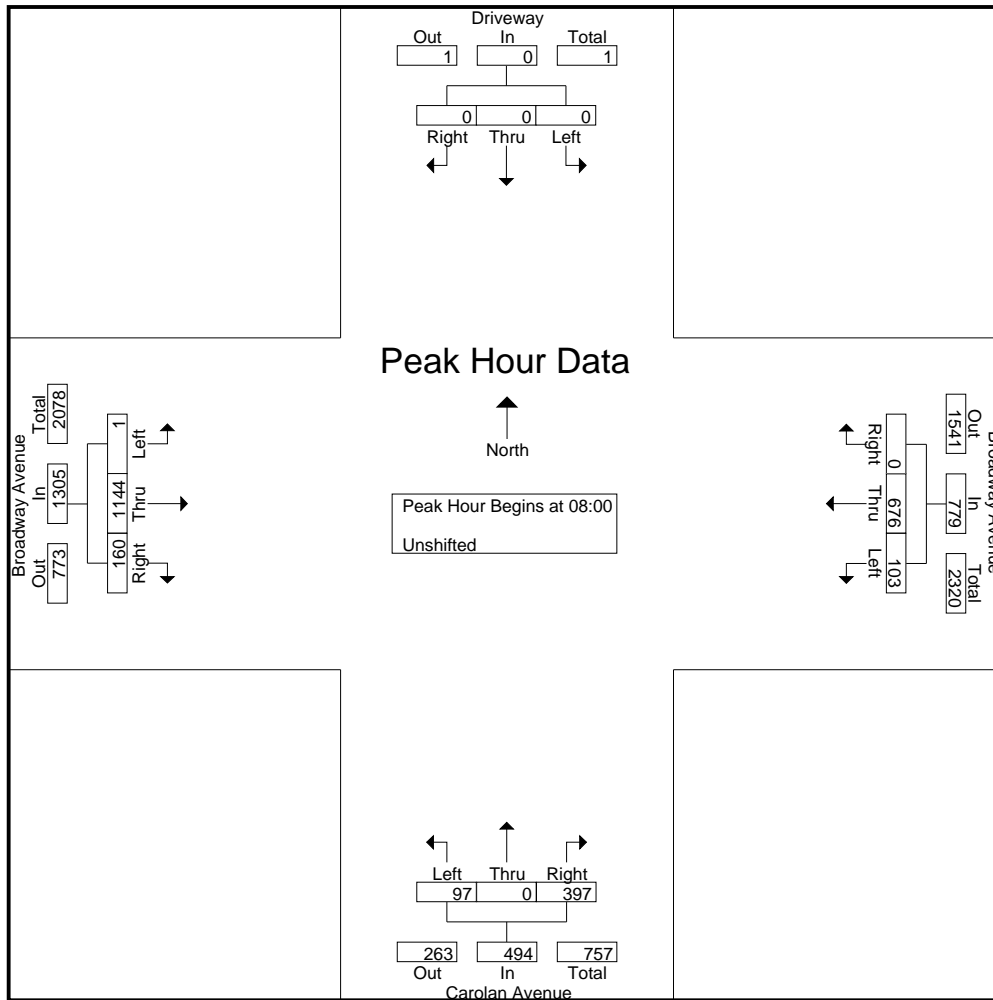

Peak Hour Analysis From 16:00 to 17:45 - Peak 1 of 1
 Peak Hour for Entire Intersection Begins at 17:00

17:00	0	0	0	0	49	275	0	324	30	0	84	114	0	230	28	258	696
17:15	0	0	0	0	46	283	1	330	14	0	77	91	1	245	32	278	699
17:30	0	0	0	0	53	272	0	325	17	0	76	93	0	230	19	249	667
17:45	0	0	0	0	47	271	0	318	25	1	74	100	0	210	25	235	653
Total Volume	0	0	0	0	195	1101	1	1297	86	1	311	398	1	915	104	1020	2715
% App. Total	0	0	0	0	15	84.9	0.1		21.6	0.3	78.1		0.1	89.7	10.2		
PHF	.000	.000	.000	.000	.920	.973	.250	.983	.717	.250	.926	.873	.250	.934	.813	.917	.971

All Traffic Data

(916) 771-8700

City of Burlingame

File Name : 12-7153-003 Carolan-Broadway

Site Code : 00000000

Start Date : 4/18/2012

Page No : 3

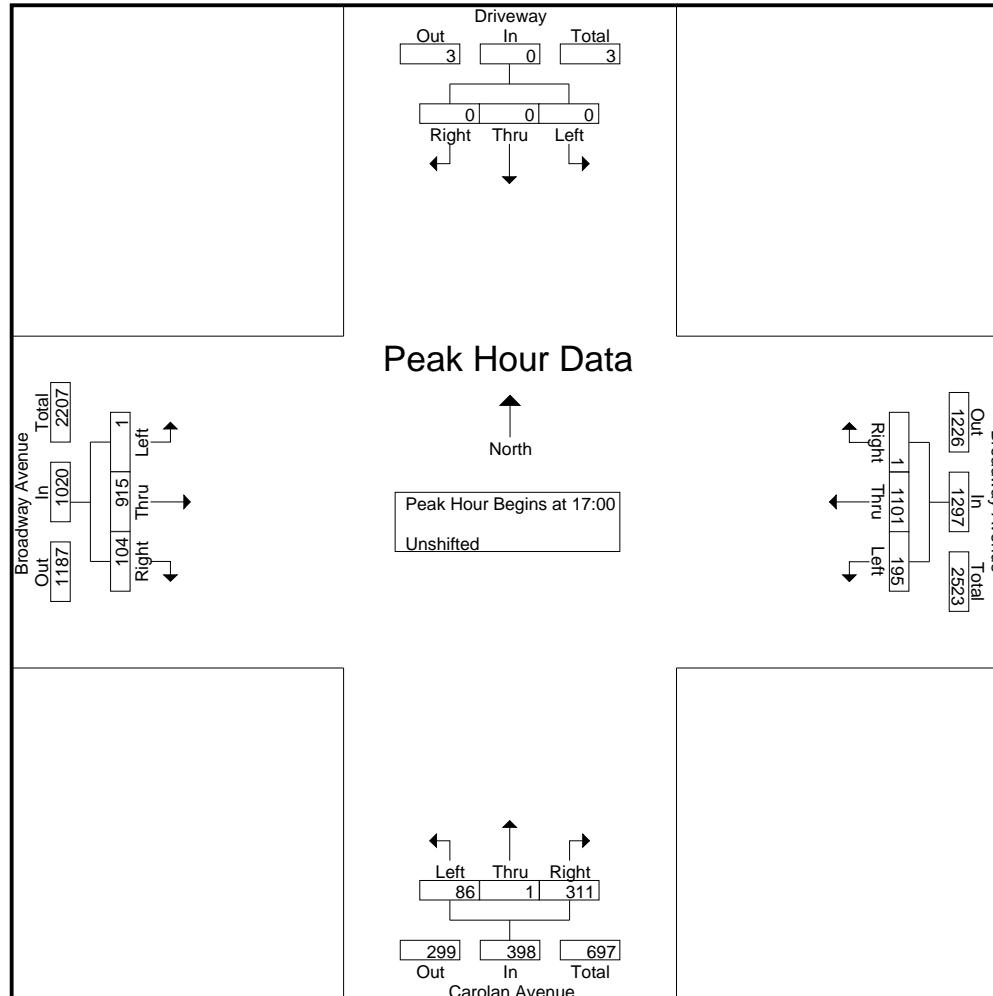

All Traffic Data

(916) 771-8700

City of Burlingame

File Name : 12-7153-004 Carolan-Oak Grove

Site Code : 00000000

Start Date : 4/18/2012

Page No : 1

Groups Printed- Unshifted

Start Time	Carolan Avenue Southbound				Oak Grove Avenue Westbound				Carolan Avenue Northbound				Oak Grove Avenue Eastbound				Int. Total
	Left	Thru	Right	App. Total	Left	Thru	Right	App. Total	Left	Thru	Right	App. Total	Left	Thru	Right	App. Total	
07:00	2	12	18	32	5	7	5	17	0	6	0	6	66	12	1	79	134
07:15	1	14	19	34	4	7	4	15	1	11	0	12	88	6	3	97	158
07:30	2	17	24	43	5	13	1	19	3	11	3	17	73	4	2	79	158
07:45	0	25	39	64	3	15	2	20	2	14	1	17	116	11	0	127	228
Total	5	68	100	173	17	42	12	71	6	42	4	52	343	33	6	382	678
08:00	0	10	38	48	4	24	1	29	7	12	6	25	109	9	5	123	225
08:15	1	23	50	74	4	37	4	45	4	14	5	23	102	23	5	130	272
08:30	2	28	44	74	4	30	5	39	8	29	12	49	88	35	19	142	304
08:45	1	45	37	83	5	35	6	46	24	37	14	75	79	53	53	185	389
Total	4	106	169	279	17	126	16	159	43	92	37	172	378	120	82	580	1190
16:00	3	15	48	66	2	16	1	19	5	12	8	25	70	20	8	98	208
16:15	7	21	46	74	5	21	2	28	6	23	9	38	74	23	11	108	248
16:30	2	23	59	84	3	28	5	36	10	26	8	44	67	21	12	100	264
16:45	5	35	49	89	18	23	4	45	8	15	10	33	66	27	17	110	277
Total	17	94	202	313	28	88	12	128	29	76	35	140	277	91	48	416	997
17:00	4	32	60	96	10	35	4	49	19	28	12	59	71	29	16	116	320
17:15	7	36	61	104	10	29	5	44	8	19	7	34	84	29	18	131	313
17:30	4	30	71	105	9	36	2	47	8	25	13	46	77	37	11	125	323
17:45	10	33	57	100	9	33	4	46	14	24	14	52	68	38	7	113	311
Total	25	131	249	405	38	133	15	186	49	96	46	191	300	133	52	485	1267
Grand Total	51	399	720	1170	100	389	55	544	127	306	122	555	1298	377	188	1863	4132
Apprch %	4.4	34.1	61.5		18.4	71.5	10.1		22.9	55.1	22		69.7	20.2	10.1		
Total %	1.2	9.7	17.4	28.3	2.4	9.4	1.3	13.2	3.1	7.4	3	13.4	31.4	9.1	4.5	45.1	

Start Time	Carolan Avenue Southbound				Oak Grove Avenue Westbound				Carolan Avenue Northbound				Oak Grove Avenue Eastbound				Int. Total
	Left	Thru	Right	App. Total	Left	Thru	Right	App. Total	Left	Thru	Right	App. Total	Left	Thru	Right	App. Total	
Peak Hour Analysis From 07:00 to 08:45 - Peak 1 of 1																	
Peak Hour for Entire Intersection Begins at 08:00																	
08:00	0	10	38	48	4	24	1	29	7	12	6	25	109	9	5	123	225
08:15	1	23	50	74	4	37	4	45	4	14	5	23	102	23	5	130	272
08:30	2	28	44	74	4	30	5	39	8	29	12	49	88	35	19	142	304
08:45	1	45	37	83	5	35	6	46	24	37	14	75	79	53	53	185	389
Total Volume	4	106	169	279	17	126	16	159	43	92	37	172	378	120	82	580	1190
% App. Total	1.4	38	60.6		10.7	79.2	10.1		25	53.5	21.5		65.2	20.7	14.1		

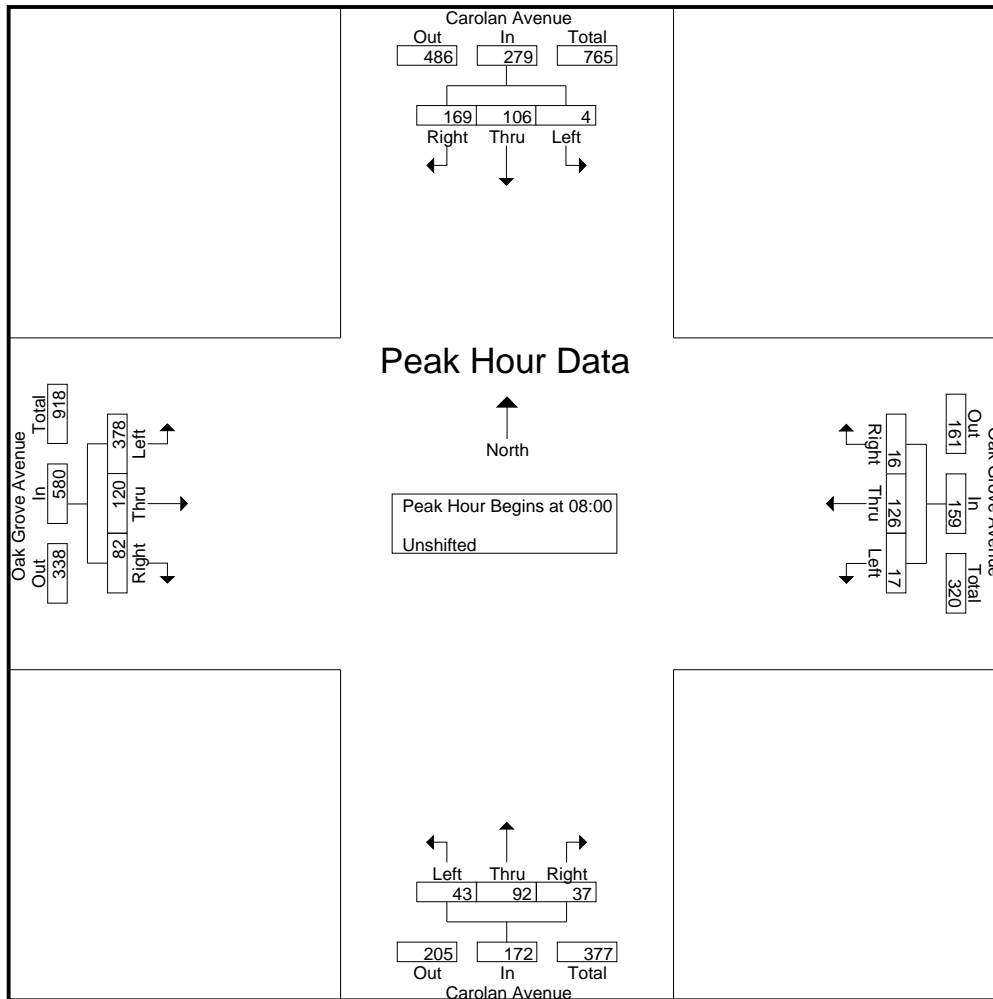

Peak Hour Analysis From 16:00 to 17:45 - Peak 1 of 1
 Peak Hour for Entire Intersection Begins at 17:00

17:00	4	32	60	96	10	35	4	49	19	28	12	59	71	29	16	116	320
17:15	7	36	61	104	10	29	5	44	8	19	7	34	84	29	18	131	313
17:30	4	30	71	105	9	36	2	47	8	25	13	46	77	37	11	125	323
17:45	10	33	57	100	9	33	4	46	14	24	14	52	68	38	7	113	311
Total Volume	25	131	249	405	38	133	15	186	49	96	46	191	300	133	52	485	1267
% App. Total	6.2	32.3	61.5		20.4	71.5	8.1		25.7	50.3	24.1		61.9	27.4	10.7		
PHF	.625	.910	.877	.964	.950	.924	.750	.949	.645	.857	.821	.809	.893	.875	.722	.926	.981

All Traffic Data

(916) 771-8700

City of Burlingame

File Name : 12-7153-004 Carolan-Oak Grove

Site Code : 00000000

Start Date : 4/18/2012

Page No : 3

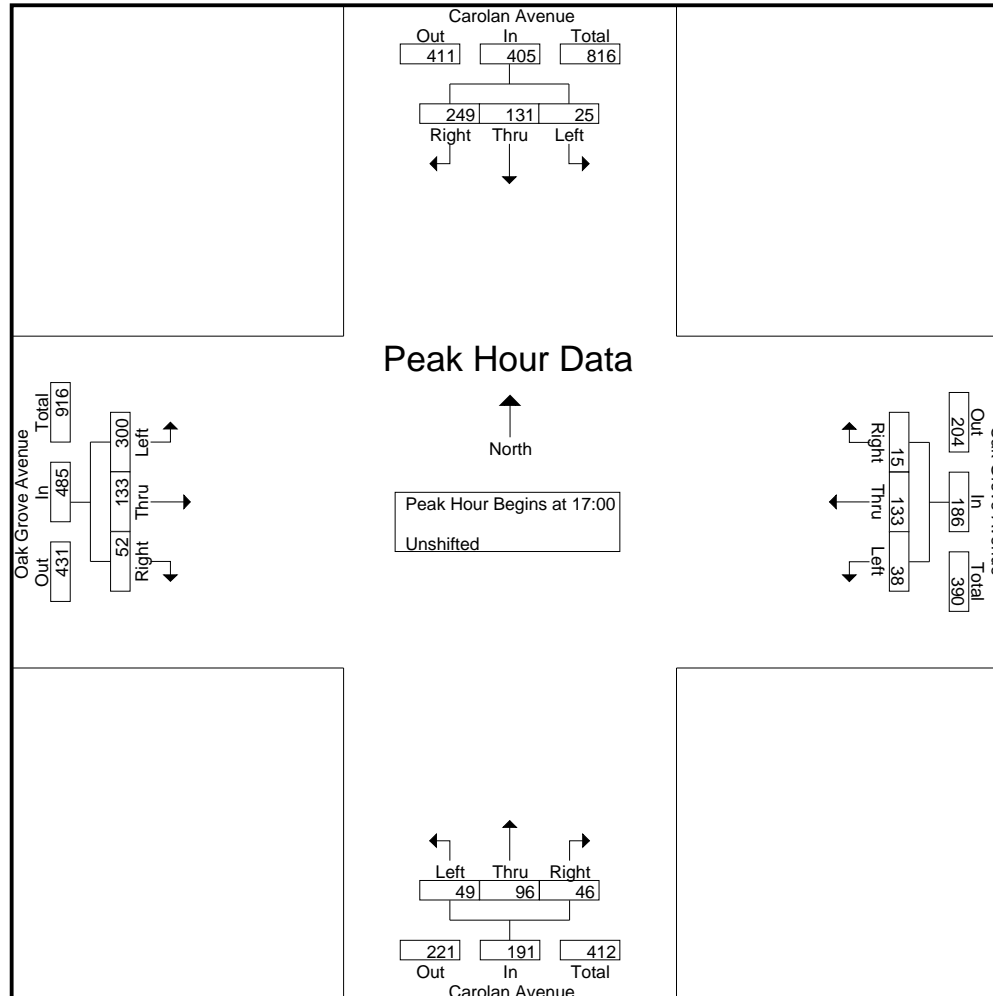

Traffic Data Service

Campbell, CA
 (408) 377-2988
 tdsbay@cs.com

File Name : 24AM FINAL
 Site Code : 00000024
 Start Date : 6/4/2013
 Page No : 1

Groups Printed- Vehicles

Start Time	CALIFORNIA DR Southbound					OAK GROVE AVE Westbound					CALIFORNIA DR Northbound					OAK GROVE AVE Eastbound					Int. Total
	Right	Thru	Left	Peds	App. Total	Right	Thru	Left	Peds	App. Total	Right	Thru	Left	Peds	App. Total	Right	Thru	Left	Peds	App. Total	
07:00 AM	2	59	2	0	63	7	6	19	0	32	45	43	1	2	91	4	33	1	2	40	226
07:15 AM	2	87	5	0	94	5	7	24	0	36	46	68	6	4	124	5	41	10	0	56	310
07:30 AM	2	119	2	3	126	6	5	37	0	48	67	83	0	5	155	9	29	10	1	49	378
07:45 AM	9	157	7	2	175	11	12	39	0	62	71	98	3	3	175	8	35	9	1	53	465
Total	15	422	16	5	458	29	30	119	0	178	229	292	10	14	545	26	138	30	4	198	1379
08:00 AM	6	144	8	3	161	23	25	36	2	86	59	110	3	3	175	2	28	5	3	38	460
08:15 AM	11	145	12	9	177	27	29	33	0	89	59	135	8	1	203	7	35	14	3	59	528
08:30 AM	7	184	14	7	212	17	22	37	0	76	51	112	5	3	171	7	56	9	7	79	538
08:45 AM	5	149	22	5	181	14	19	49	1	83	54	115	5	2	176	6	47	10	8	71	511
Total	29	622	56	24	731	81	95	155	3	334	223	472	21	9	725	22	166	38	21	247	2037
Grand Total	44	1044	72	29	1189	110	125	274	3	512	452	764	31	23	1270	48	304	68	25	445	3416
Apprch %	3.7	87.8	6.1	2.4		21.5	24.4	53.5	0.6		35.6	60.2	2.4	1.8		10.8	68.3	15.3	5.6		
Total %	1.3	30.6	2.1	0.8	34.8	3.2	3.7	8	0.1	15	13.2	22.4	0.9	0.7	37.2	1.4	8.9	2	0.7	13	

Start Time	CALIFORNIA DR Southbound				OAK GROVE AVE Westbound				CALIFORNIA DR Northbound				OAK GROVE AVE Eastbound				Int. Total
	Right	Thru	Left	App. Total	Right	Thru	Left	App. Total	Right	Thru	Left	App. Total	Right	Thru	Left	App. Total	
Peak Hour Analysis From 07:00 AM to 08:45 AM - Peak 1 of 1																	
Peak Hour for Entire Intersection Begins at 08:00 AM																	
08:00 AM	6	144	8	158	23	25	36	84	59	110	3	172	2	28	5	35	449
08:15 AM	11	145	12	168	27	29	33	89	59	135	8	202	7	35	14	56	515
08:30 AM	7	184	14	205	17	22	37	76	51	112	5	168	7	56	9	72	521
08:45 AM	5	149	22	176	14	19	49	82	54	115	5	174	6	47	10	63	495
Total Volume	29	622	56	707	81	95	155	331	223	472	21	716	22	166	38	226	1980
% App. Total	4.1	88	7.9		24.5	28.7	46.8		31.1	65.9	2.9		9.7	73.5	16.8		
PHF	.659	.845	.636	.862	.750	.819	.791	.930	.945	.874	.656	.886	.786	.741	.679	.785	.950

Traffic Data Service

Campbell, CA
(408) 377-2988
tdsbay@cs.com

File Name : 24AM FINAL
Site Code : 00000024
Start Date : 6/4/2013
Page No : 2

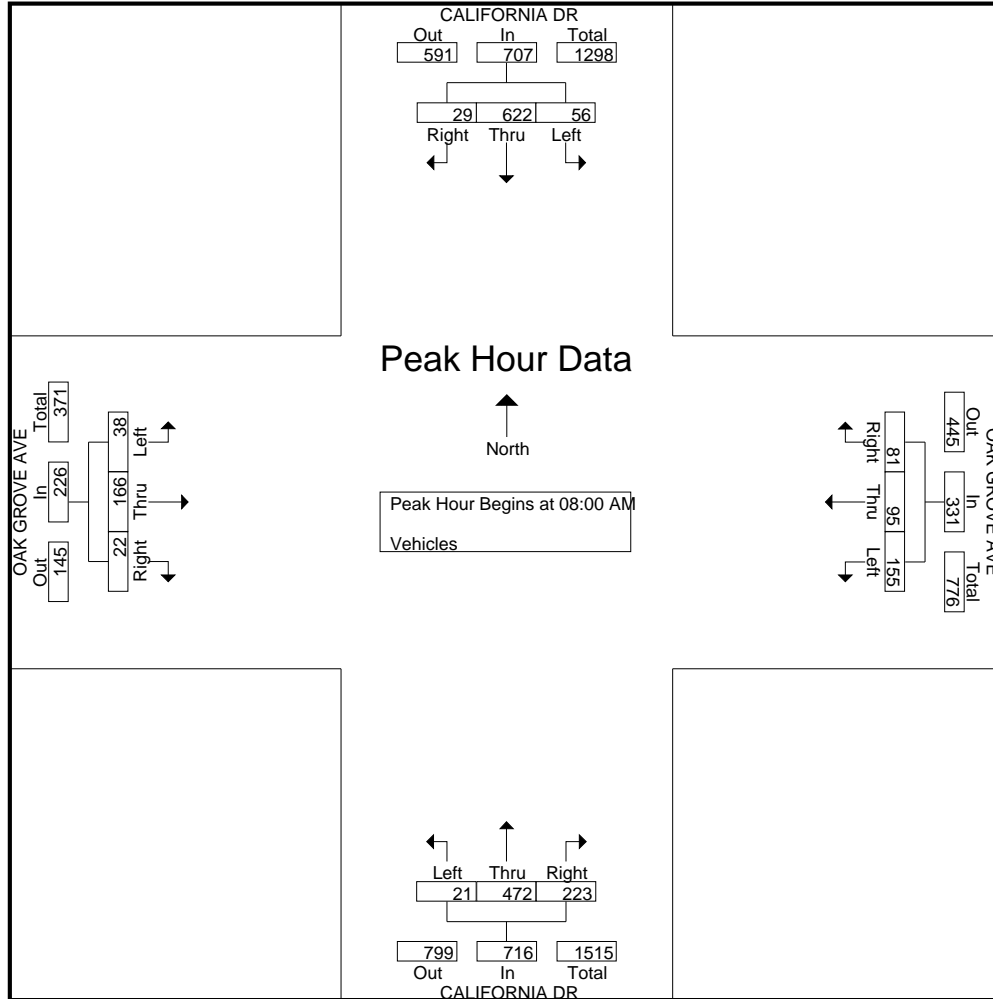

Traffic Data Service

Campbell, CA
 (408) 377-2988
 tdsbay@cs.com

File Name : 24AM FINAL
 Site Code : 00000024
 Start Date : 6/4/2013
 Page No : 1

Groups Printed- Bikes

Start Time	CALIFORNIA DR Southbound					OAK GROVE AVE Westbound					CALIFORNIA DR Northbound					OAK GROVE AVE Eastbound					Int. Total
	Right	Thru	Left	Peds	App. Total	Right	Thru	Left	Peds	App. Total	Right	Thru	Left	Peds	App. Total	Right	Thru	Left	Peds	App. Total	
07:00 AM	0	0	0	0	0	0	1	1	0	2	0	1	0	0	1	0	1	0	0	1	4
07:15 AM	0	0	0	0	0	0	0	0	0	0	0	0	0	0	0	0	0	0	0	0	0
07:30 AM	0	0	0	0	0	0	0	0	0	0	0	1	0	0	1	1	0	0	0	1	2
07:45 AM	0	2	0	0	2	0	0	0	0	0	0	0	0	0	0	0	0	0	0	0	2
Total	0	2	0	0	2	0	1	1	0	2	0	2	0	0	2	1	1	0	0	2	8
08:00 AM	0	0	0	0	0	1	0	0	0	1	0	0	0	0	0	0	0	0	0	0	1
08:15 AM	0	0	0	0	0	0	0	1	0	1	0	0	0	0	0	0	1	0	0	1	2
08:30 AM	0	4	0	0	4	0	0	1	0	1	0	0	0	0	0	0	0	0	0	0	5
08:45 AM	0	3	0	0	3	0	0	1	0	1	0	2	1	0	3	0	0	0	0	0	7
Total	0	7	0	0	7	1	0	3	0	4	0	2	1	0	3	0	1	0	0	1	15
Grand Total	0	9	0	0	9	1	1	4	0	6	0	4	1	0	5	1	2	0	0	3	23
Apprch %	0	100	0	0		16.7	16.7	66.7	0		0	80	20	0		33.3	66.7	0	0		
Total %	0	39.1	0	0	39.1	4.3	4.3	17.4	0	26.1	0	17.4	4.3	0	21.7	4.3	8.7	0	0	13	

Start Time	CALIFORNIA DR Southbound				OAK GROVE AVE Westbound				CALIFORNIA DR Northbound				OAK GROVE AVE Eastbound				Int. Total
	Right	Thru	Left	App. Total	Right	Thru	Left	App. Total	Right	Thru	Left	App. Total	Right	Thru	Left	App. Total	
08:00 AM	0	0	0	0	1	0	0	1	0	0	0	0	0	0	0	0	1
08:15 AM	0	0	0	0	0	0	1	1	0	0	0	0	0	1	0	1	2
08:30 AM	0	4	0	4	0	0	1	1	0	0	0	0	0	0	0	0	5
08:45 AM	0	3	0	3	0	0	1	1	0	2	1	3	0	0	0	0	7
Total Volume	0	7	0	7	1	0	3	4	0	2	1	3	0	1	0	1	15
% App. Total	0	100	0		25	0	75		0	66.7	33.3		0	100	0		
PHF	.000	.438	.000	.438	.250	.000	.750	1.00	.000	.250	.250	.250	.000	.250	.000	.250	.536

Peak Hour Analysis From 07:00 AM to 08:45 AM - Peak 1 of 1

Peak Hour for Entire Intersection Begins at 08:00 AM

Traffic Data Service

Campbell, CA
(408) 377-2988
tdsbay@cs.com

File Name : 24AM FINAL
Site Code : 00000024
Start Date : 6/4/2013
Page No : 2

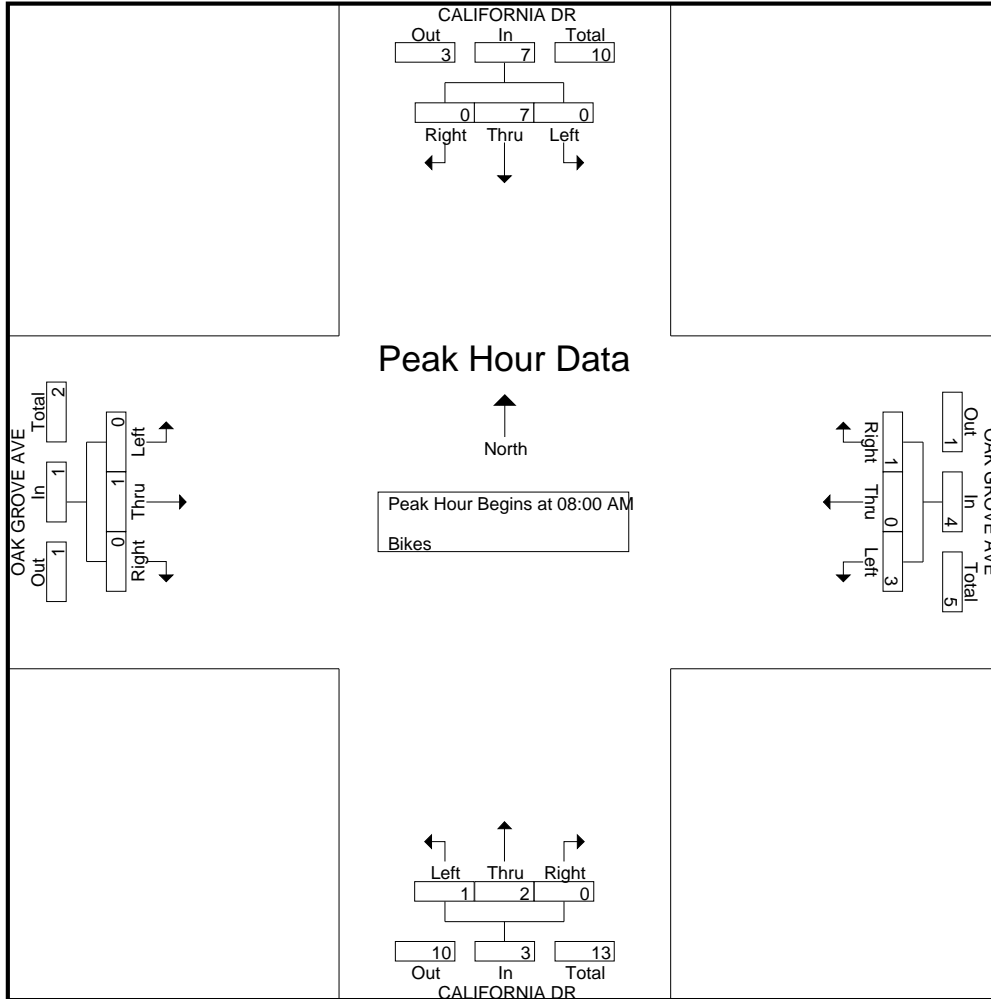

Traffic Data Service

Campbell, CA
 (408) 377-2988
 tdsbay@cs.com

File Name : 24PM FINAL
 Site Code : 00000024
 Start Date : 6/4/2013
 Page No : 1

Groups Printed- Vehicles

Start Time	CALIFORNIA DR Southbound					OAK GROVE AVE Westbound					CALIFORNIA DR Northbound					OAK GROVE AVE Eastbound					Int. Total
	Right	Thru	Left	Peds	App. Total	Right	Thru	Left	Peds	App. Total	Right	Thru	Left	Peds	App. Total	Right	Thru	Left	Peds	App. Total	
04:00 PM	7	151	14	4	176	5	18	51	0	74	59	121	5	1	186	5	22	5	6	38	474
04:15 PM	20	151	13	0	184	9	23	50	0	82	47	126	3	2	178	6	34	4	3	47	491
04:30 PM	12	139	9	0	160	10	25	47	0	82	44	122	12	6	184	4	17	5	10	36	462
04:45 PM	8	151	12	6	177	10	21	46	0	77	58	122	3	1	184	7	32	7	12	58	496
Total	47	592	48	10	697	34	87	194	0	315	208	491	23	10	732	22	105	21	31	179	1923
05:00 PM	17	178	8	2	205	17	24	57	0	98	63	136	6	2	207	8	26	6	3	43	553
05:15 PM	15	163	9	4	191	16	31	37	0	84	65	135	11	0	211	10	29	10	6	55	541
05:30 PM	8	162	10	1	181	13	26	45	1	85	63	141	9	8	221	7	32	6	1	46	533
05:45 PM	15	177	14	1	207	9	34	52	0	95	51	132	7	3	193	7	28	6	3	44	539
Total	55	680	41	8	784	55	115	191	1	362	242	544	33	13	832	32	115	28	13	188	2166
Grand Total	102	1272	89	18	1481	89	202	385	1	677	450	1035	56	23	1564	54	220	49	44	367	4089
Apprch %	6.9	85.9	6	1.2		13.1	29.8	56.9	0.1		28.8	66.2	3.6	1.5		14.7	59.9	13.4	12		
Total %	2.5	31.1	2.2	0.4	36.2	2.2	4.9	9.4	0	16.6	11	25.3	1.4	0.6	38.2	1.3	5.4	1.2	1.1	9	

Start Time	CALIFORNIA DR Southbound				OAK GROVE AVE Westbound				CALIFORNIA DR Northbound				OAK GROVE AVE Eastbound				Int. Total
	Right	Thru	Left	App. Total	Right	Thru	Left	App. Total	Right	Thru	Left	App. Total	Right	Thru	Left	App. Total	
Peak Hour Analysis From 04:00 PM to 05:45 PM - Peak 1 of 1																	
Peak Hour for Entire Intersection Begins at 05:00 PM																	
05:00 PM	17	178	8	203	17	24	57	98	63	136	6	205	8	26	6	40	546
05:15 PM	15	163	9	187	16	31	37	84	65	135	11	211	10	29	10	49	531
05:30 PM	8	162	10	180	13	26	45	84	63	141	9	213	7	32	6	45	522
05:45 PM	15	177	14	206	9	34	52	95	51	132	7	190	7	28	6	41	532
Total Volume	55	680	41	776	55	115	191	361	242	544	33	819	32	115	28	175	2131
% App. Total	7.1	87.6	5.3		15.2	31.9	52.9		29.5	66.4	4		18.3	65.7	16		
PHF	.809	.955	.732	.942	.809	.846	.838	.921	.931	.965	.750	.961	.800	.898	.700	.893	.976

Traffic Data Service

Campbell, CA
(408) 377-2988
tdsbay@cs.com

File Name : 24PM FINAL
Site Code : 00000024
Start Date : 6/4/2013
Page No : 2

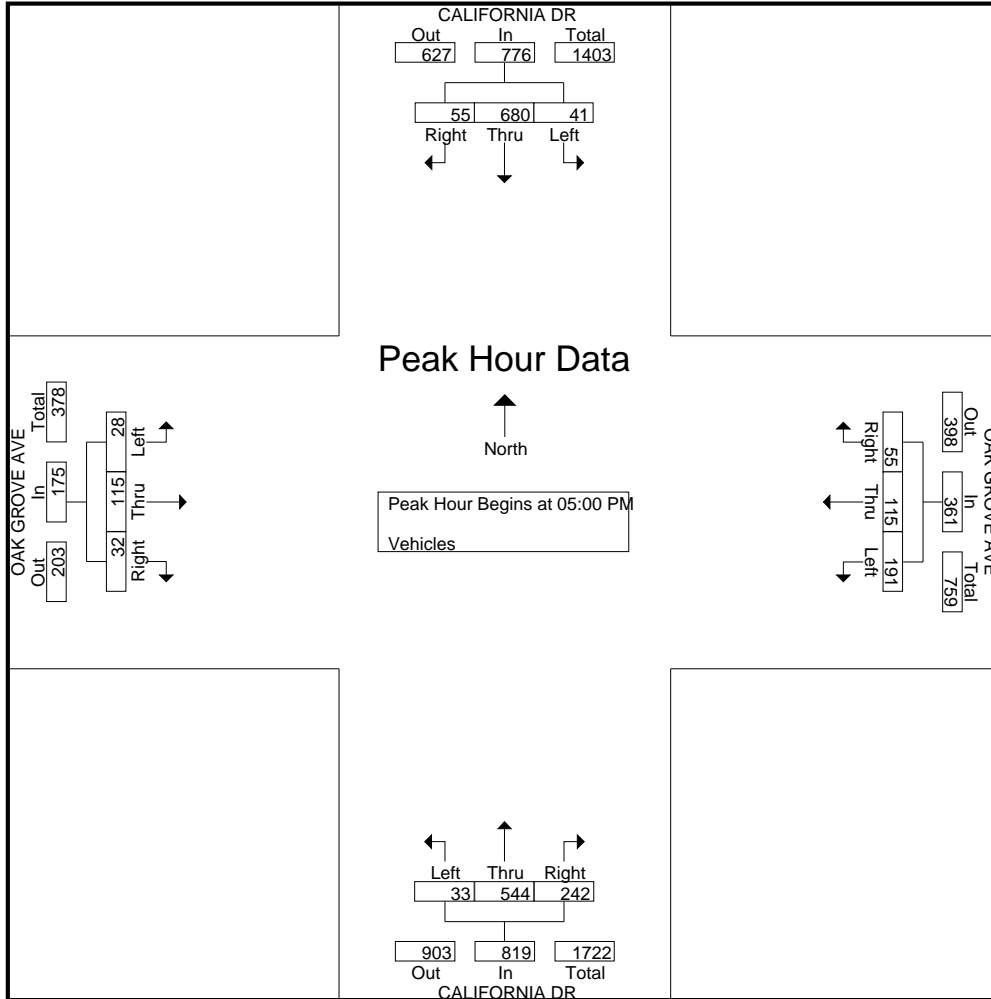

Traffic Data Service

Campbell, CA
 (408) 377-2988
 tdsbay@cs.com

File Name : 24PM FINAL
 Site Code : 00000024
 Start Date : 6/4/2013
 Page No : 1

Groups Printed- Bikes

Start Time	CALIFORNIA DR Southbound					OAK GROVE AVE Westbound					CALIFORNIA DR Northbound					OAK GROVE AVE Eastbound					Int. Total					
	Right	Thru	Left	Peds	App. Total	Right	Thru	Left	Peds	App. Total	Right	Thru	Left	Peds	App. Total	Right	Thru	Left	Peds	App. Total						
04:00 PM	0	1	0	0	1	0	0	0	0	0	0	1	0	0	1	0	0	0	0	0	0	0	0	0	0	2
04:15 PM	0	1	0	0	1	0	0	0	0	0	0	1	0	0	1	0	1	0	0	0	0	1	0	0	1	3
04:30 PM	0	1	0	0	1	0	0	1	0	1	0	0	0	0	0	0	0	0	0	0	0	0	0	0	0	2
04:45 PM	0	0	0	0	0	0	0	0	0	0	1	0	0	0	1	0	0	0	0	0	0	0	0	0	0	1
Total	0	3	0	0	3	0	0	1	0	1	1	2	0	0	3	0	1	0	0	1	0	1	0	0	1	8
05:00 PM	0	0	0	0	0	0	0	0	0	0	1	2	0	0	3	0	0	0	0	0	0	0	0	0	0	3
05:15 PM	0	3	0	0	3	0	0	0	0	0	0	1	0	0	1	0	0	0	0	0	0	0	0	0	0	4
05:30 PM	0	1	0	0	1	0	0	0	0	0	0	0	0	0	0	0	0	0	0	0	0	0	0	0	0	1
05:45 PM	0	1	0	0	1	0	0	0	0	0	1	3	0	0	4	0	0	0	0	0	0	0	0	0	0	5
Total	0	5	0	0	5	0	0	0	0	0	2	6	0	0	8	0	0	0	0	0	0	0	0	0	0	13
Grand Total	0	8	0	0	8	0	0	1	0	1	3	8	0	0	11	0	1	0	0	1	0	1	0	0	1	21
Apprch %	0	100	0	0		0	0	100	0		27.3	72.7	0	0		0	100	0	0		0	100	0	0		
Total %	0	38.1	0	0	38.1	0	0	4.8	0	4.8	14.3	38.1	0	0	52.4	0	4.8	0	0	4.8	0	4.8	0	0	4.8	

Start Time	CALIFORNIA DR Southbound				OAK GROVE AVE Westbound				CALIFORNIA DR Northbound				OAK GROVE AVE Eastbound				Int. Total
	Right	Thru	Left	App. Total	Right	Thru	Left	App. Total	Right	Thru	Left	App. Total	Right	Thru	Left	App. Total	
Peak Hour Analysis From 04:00 PM to 05:45 PM - Peak 1 of 1																	
Peak Hour for Entire Intersection Begins at 05:00 PM																	
05:00 PM	0	0	0	0	0	0	0	0	1	2	0	3	0	0	0	0	3
05:15 PM	0	3	0	3	0	0	0	0	0	1	0	1	0	0	0	0	4
05:30 PM	0	1	0	1	0	0	0	0	0	0	0	0	0	0	0	0	1
05:45 PM	0	1	0	1	0	0	0	0	1	3	0	4	0	0	0	0	5
Total Volume	0	5	0	5	0	0	0	0	2	6	0	8	0	0	0	0	13
% App. Total	0	100	0		0	0	0		25	75	0		0	0	0		
PHF	.000	.417	.000	.417	.000	.000	.000	.000	.500	.500	.000	.500	.000	.000	.000	.000	.650

Traffic Data Service

Campbell, CA

(408) 377-2988

tdsbay@cs.com

File Name : 24PM FINAL

Site Code : 00000024

Start Date : 6/4/2013

Page No : 2

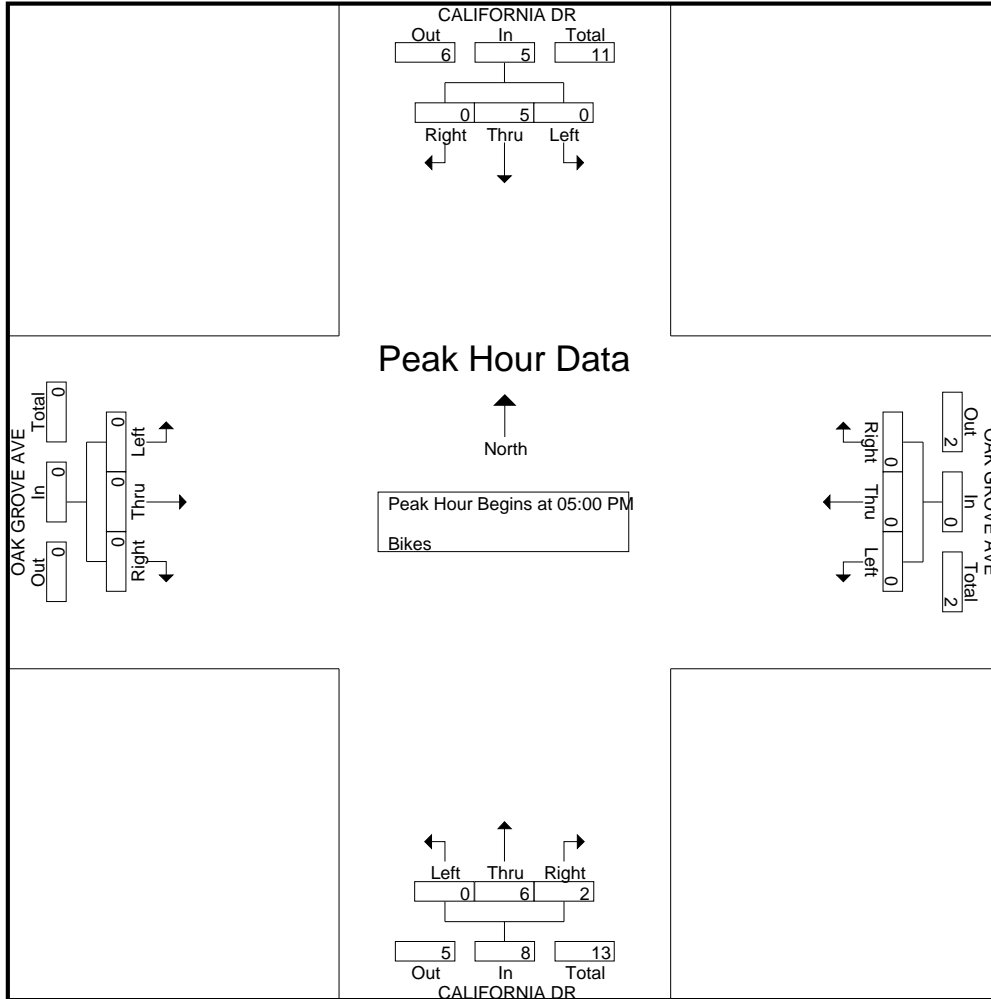

Traffic Data Service

Campbell, CA
 (408) 377-2988
 tdsbay@cs.com

File Name : 26AM FINAL
 Site Code : 00000026
 Start Date : 6/6/2013
 Page No : 1

Groups Printed- Vehicles

Start Time	CALIFORNIA DR Southbound					NORTH LN Westbound					CALIFORNIA DR Northbound					Eastbound					Int. Total
	Right	Thru	Left	Peds	App. Total	Right	Thru	Left	Peds	App. Total	Right	Thru	Left	Peds	App. Total	Right	Thru	Left	Peds	App. Total	
07:00 AM	0	61	9	0	70	7	0	7	3	17	11	57	0	12	80	0	0	0	0	0	167
07:15 AM	0	67	16	0	83	7	0	3	5	15	20	81	0	14	115	0	0	0	0	0	213
07:30 AM	0	80	13	0	93	15	0	3	2	20	12	101	0	22	135	0	0	0	0	0	248
07:45 AM	0	126	23	0	149	8	0	8	2	18	9	145	0	19	173	0	0	0	0	0	340
Total	0	334	61	0	395	37	0	21	12	70	52	384	0	67	503	0	0	0	0	0	968
08:00 AM	0	138	14	0	152	11	0	3	10	24	14	172	0	26	212	0	0	0	0	0	388
08:15 AM	0	129	25	0	154	24	0	5	5	34	24	175	0	33	232	0	0	0	0	0	420
08:30 AM	0	170	35	0	205	13	0	6	1	20	18	159	0	38	215	0	0	0	0	0	440
08:45 AM	0	183	40	0	223	17	0	5	7	29	16	161	0	48	225	0	0	0	0	0	477
Total	0	620	114	0	734	65	0	19	23	107	72	667	0	145	884	0	0	0	0	0	1725
Grand Total	0	954	175	0	1129	102	0	40	35	177	124	1051	0	212	1387	0	0	0	0	0	2693
Apprch %	0	84.5	15.5	0		57.6	0	22.6	19.8		8.9	75.8	0	15.3		0	0	0	0		
Total %	0	35.4	6.5	0	41.9	3.8	0	1.5	1.3	6.6	4.6	39	0	7.9	51.5	0	0	0	0	0	

Start Time	CALIFORNIA DR Southbound					NORTH LN Westbound					CALIFORNIA DR Northbound					Eastbound					Int. Total
	Right	Thru	Left	Peds	App. Total	Right	Thru	Left	Peds	App. Total	Right	Thru	Left	Peds	App. Total	Right	Thru	Left	Peds	App. Total	
Peak Hour Analysis From 07:00 AM to 08:45 AM - Peak 1 of 1																					
Peak Hour for Entire Intersection Begins at 08:00 AM																					
08:00 AM	0	138	14	0	152	11	0	3	0	14	14	172	0	186	0	0	0	0	0	0	352
08:15 AM	0	129	25	0	154	24	0	5	0	29	24	175	0	199	0	0	0	0	0	0	382
08:30 AM	0	170	35	0	205	13	0	6	0	19	18	159	0	177	0	0	0	0	0	0	401
08:45 AM	0	183	40	0	223	17	0	5	0	22	16	161	0	177	0	0	0	0	0	0	422
Total Volume	0	620	114	0	734	65	0	19	0	84	72	667	0	739	0	0	0	0	0	0	1557
% App. Total	0	84.5	15.5	0		77.4	0	22.6	0		9.7	90.3	0		0	0	0	0	0		
PHF	.000	.847	.713	0	.823	.677	.000	.792	0	.724	.750	.953	.000	.928	.000	.000	.000	.000	0	.000	.922

Traffic Data Service

Campbell, CA
(408) 377-2988
tdsbay@cs.com

File Name : 26AM FINAL
Site Code : 00000026
Start Date : 6/6/2013
Page No : 2

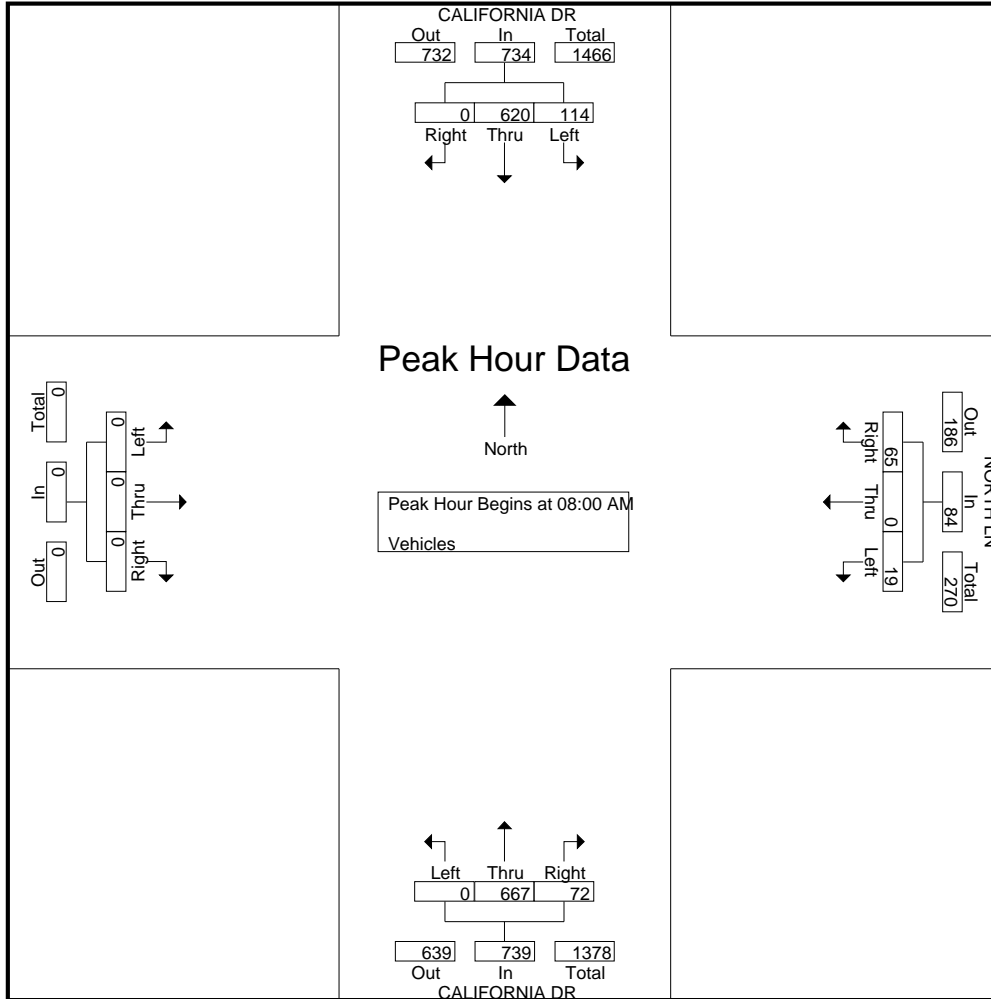

Traffic Data Service

Campbell, CA
 (408) 377-2988
 tdsbay@cs.com

File Name : 26AM FINAL
 Site Code : 00000026
 Start Date : 6/6/2013
 Page No : 1

Groups Printed- Bikes

Start Time	CALIFORNIA DR Southbound					NORTH LN Westbound					CALIFORNIA DR Northbound					Eastbound					Int. Total	
	Right	Thru	Left	Peds	App. Total	Right	Thru	Left	Peds	App. Total	Right	Thru	Left	Peds	App. Total	Right	Thru	Left	Peds	App. Total		
07:00 AM	0	1	1	0	2	0	0	0	0	0	0	0	0	0	0	0	0	0	0	0	0	2
07:15 AM	0	3	1	0	4	0	0	0	0	0	0	0	0	0	0	0	0	0	0	0	0	4
07:30 AM	0	2	0	0	2	0	0	0	0	0	0	1	0	0	1	0	0	0	0	0	0	3
07:45 AM	0	2	1	0	3	0	0	0	0	0	0	1	0	0	1	0	0	0	0	0	0	4
Total	0	8	3	0	11	0	0	0	0	0	0	2	0	0	2	0	0	0	0	0	0	13
08:00 AM	0	0	0	0	0	0	0	0	0	0	0	2	0	0	2	0	0	0	0	0	0	2
08:15 AM	0	0	0	0	0	0	0	0	0	0	1	1	0	0	2	0	0	0	0	0	0	2
08:30 AM	0	2	2	0	4	0	0	0	0	0	0	0	0	0	0	0	0	0	0	0	0	4
08:45 AM	0	1	0	0	1	0	0	0	0	0	0	0	0	0	0	0	0	0	0	0	0	1
Total	0	3	2	0	5	0	0	0	0	0	1	3	0	0	4	0	0	0	0	0	0	9
Grand Total	0	11	5	0	16	0	0	0	0	0	1	5	0	0	6	0	0	0	0	0	0	22
Apprch %	0	68.8	31.2	0		0	0	0	0		16.7	83.3	0	0		0	0	0	0	0	0	
Total %	0	50	22.7	0	72.7	0	0	0	0	0	4.5	22.7	0	0	27.3	0	0	0	0	0	0	

Start Time	CALIFORNIA DR Southbound					NORTH LN Westbound					CALIFORNIA DR Northbound					Eastbound					Int. Total	
	Right	Thru	Left	Peds	App. Total	Right	Thru	Left	Peds	App. Total	Right	Thru	Left	Peds	App. Total	Right	Thru	Left	Peds	App. Total		
07:00 AM	0	1	1	0	2	0	0	0	0	0	0	0	0	0	0	0	0	0	0	0	0	2
07:15 AM	0	3	1	0	4	0	0	0	0	0	0	0	0	0	0	0	0	0	0	0	0	4
07:30 AM	0	2	0	0	2	0	0	0	0	0	0	1	0	1	0	0	0	0	0	0	0	3
07:45 AM	0	2	1	0	3	0	0	0	0	0	0	1	0	1	0	0	0	0	0	0	0	4
Total Volume	0	8	3	0	11	0	0	0	0	0	0	2	0	0	2	0	0	0	0	0	0	13
% App. Total	0	72.7	27.3	0		0	0	0	0		0	100	0	0		0	0	0	0	0	0	
PHF	.000	.667	.750	.688		.000	.000	.000	.000		.000	.500	.000	.500		.000	.000	.000	.000	.000		.813

Peak Hour Analysis From 07:00 AM to 08:45 AM - Peak 1 of 1

Peak Hour for Entire Intersection Begins at 07:00 AM

Traffic Data Service

Campbell, CA

(408) 377-2988

tdsbay@cs.com

File Name : 26AM FINAL

Site Code : 00000026

Start Date : 6/6/2013

Page No : 2

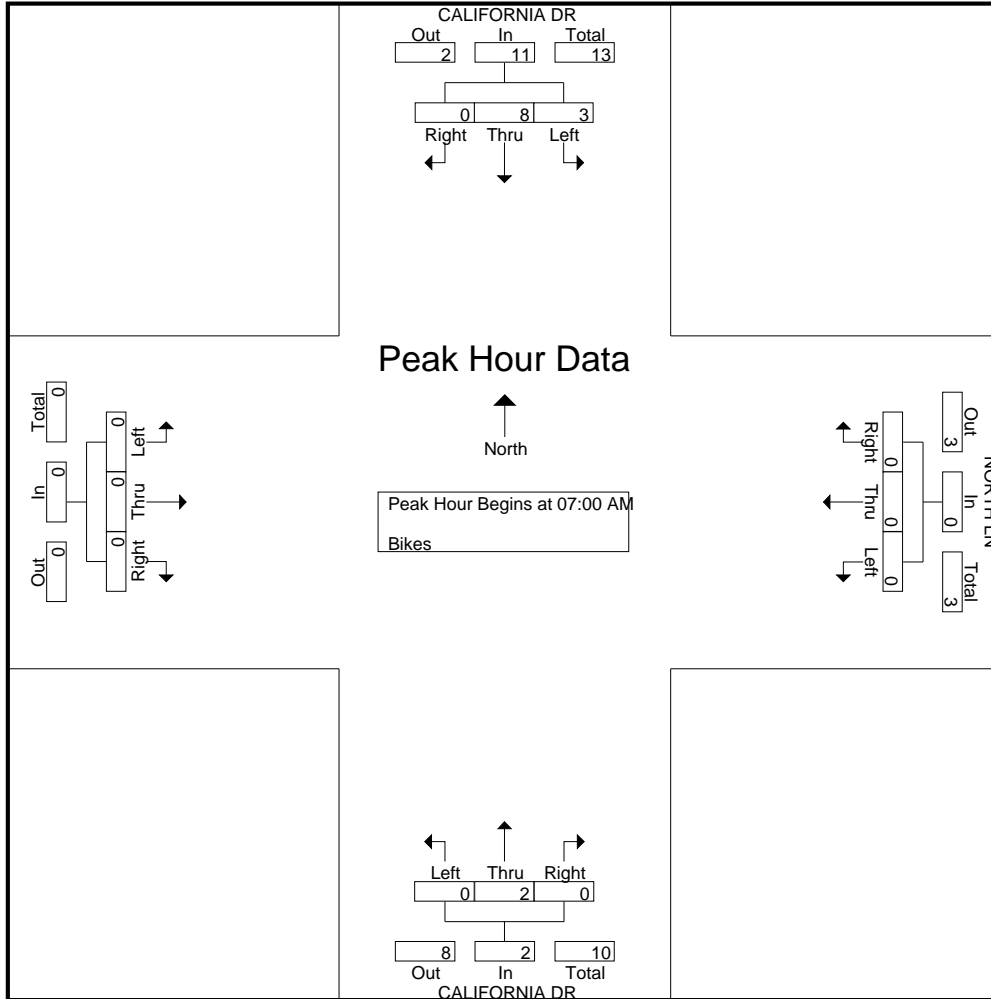

Traffic Data Service

Campbell, CA
(408) 377-2988
tdsbay@cs.com

File Name : 26PM FINAL
Site Code : 00000026
Start Date : 6/6/2013
Page No : 2

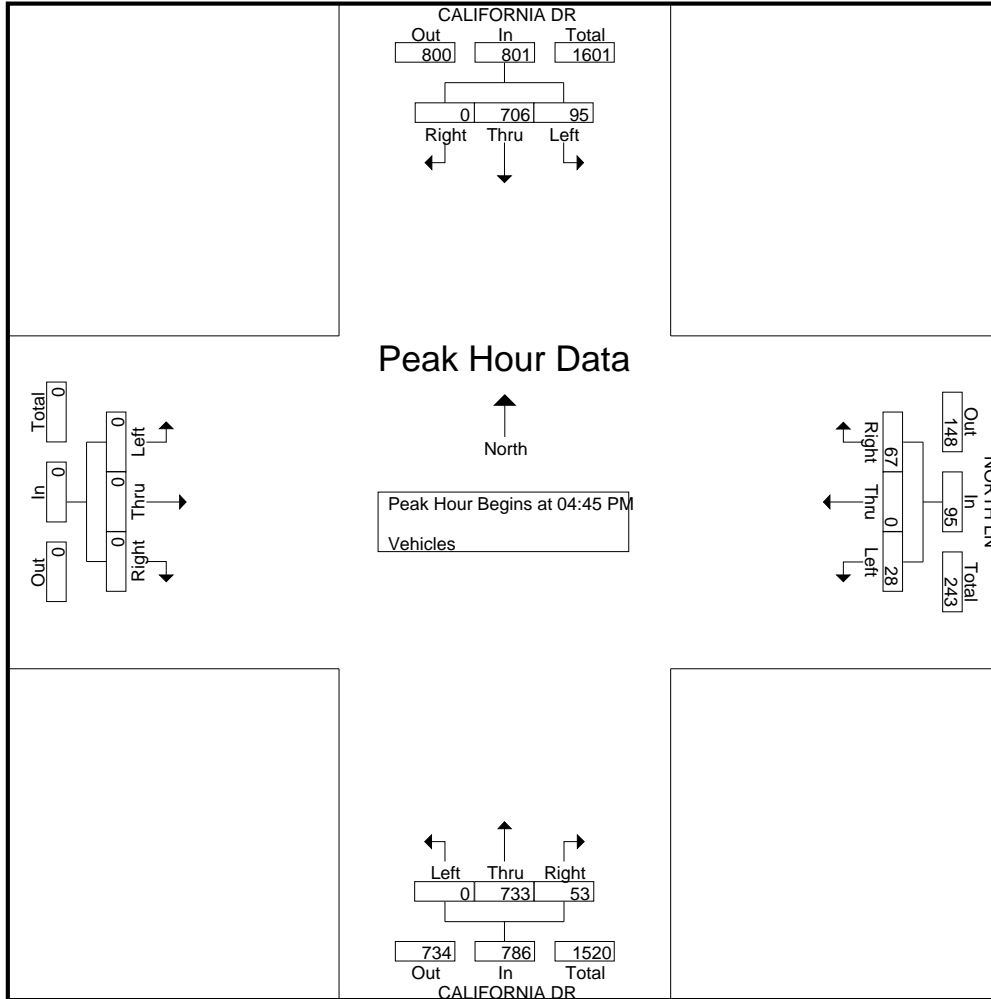

Traffic Data Service

Campbell, CA
 (408) 377-2988
 tdsbay@cs.com

File Name : 26PM FINAL
 Site Code : 00000026
 Start Date : 6/6/2013
 Page No : 1

Groups Printed- Bikes

Start Time	CALIFORNIA DR Southbound					NORTH LN Westbound					CALIFORNIA DR Northbound					Eastbound					Int. Total
	Right	Thru	Left	Peds	App. Total	Right	Thru	Left	Peds	App. Total	Right	Thru	Left	Peds	App. Total	Right	Thru	Left	Peds	App. Total	
04:00 PM	0	0	0	0	0	0	0	1	0	1	0	4	0	0	4	0	0	0	0	0	5
04:15 PM	0	0	0	0	0	0	0	0	0	0	0	1	0	0	1	0	0	0	0	0	1
04:30 PM	0	3	0	0	3	0	0	0	0	0	0	0	0	0	0	0	0	0	0	0	3
04:45 PM	0	1	1	0	2	0	0	0	0	0	1	2	0	0	3	0	0	0	0	0	5
Total	0	4	1	0	5	0	0	1	0	1	1	7	0	0	8	0	0	0	0	0	14
05:00 PM	0	0	1	0	1	0	0	0	0	0	0	0	0	0	0	0	0	0	0	0	1
05:15 PM	0	1	0	0	1	1	0	0	0	1	0	1	0	0	1	0	0	0	0	0	3
05:30 PM	0	0	1	0	1	1	0	1	0	2	1	2	0	0	3	0	0	0	0	0	6
05:45 PM	0	2	0	0	2	2	0	0	0	2	0	1	0	0	1	0	0	0	0	0	5
Total	0	3	2	0	5	4	0	1	0	5	1	4	0	0	5	0	0	0	0	0	15
Grand Total	0	7	3	0	10	4	0	2	0	6	2	11	0	0	13	0	0	0	0	0	29
Apprch %	0	70	30	0		66.7	0	33.3	0		15.4	84.6	0	0		0	0	0	0		
Total %	0	24.1	10.3	0	34.5	13.8	0	6.9	0	20.7	6.9	37.9	0	0	44.8	0	0	0	0	0	

Start Time	CALIFORNIA DR Southbound				NORTH LN Westbound				CALIFORNIA DR Northbound				Eastbound				Int. Total
	Right	Thru	Left	App. Total	Right	Thru	Left	App. Total	Right	Thru	Left	App. Total	Right	Thru	Left	App. Total	
Peak Hour Analysis From 04:00 PM to 05:45 PM - Peak 1 of 1																	
Peak Hour for Entire Intersection Begins at 04:45 PM																	
04:45 PM	0	1	1	2	0	0	0	0	1	2	0	3	0	0	0	0	5
05:00 PM	0	0	1	1	0	0	0	0	0	0	0	0	0	0	0	0	1
05:15 PM	0	1	0	1	1	0	0	1	0	1	0	1	0	0	0	0	3
05:30 PM	0	0	1	1	1	0	1	2	1	2	0	3	0	0	0	0	6
Total Volume	0	2	3	5	2	0	1	3	2	5	0	7	0	0	0	0	15
% App. Total	0	40	60		66.7	0	33.3		28.6	71.4	0		0	0	0		
PHF	.000	.500	.750	.625	.500	.000	.250	.375	.500	.625	.000	.583	.000	.000	.000	.000	.625

Traffic Data Service

Campbell, CA

(408) 377-2988

tdsbay@cs.com

File Name : 26PM FINAL

Site Code : 00000026

Start Date : 6/6/2013

Page No : 2

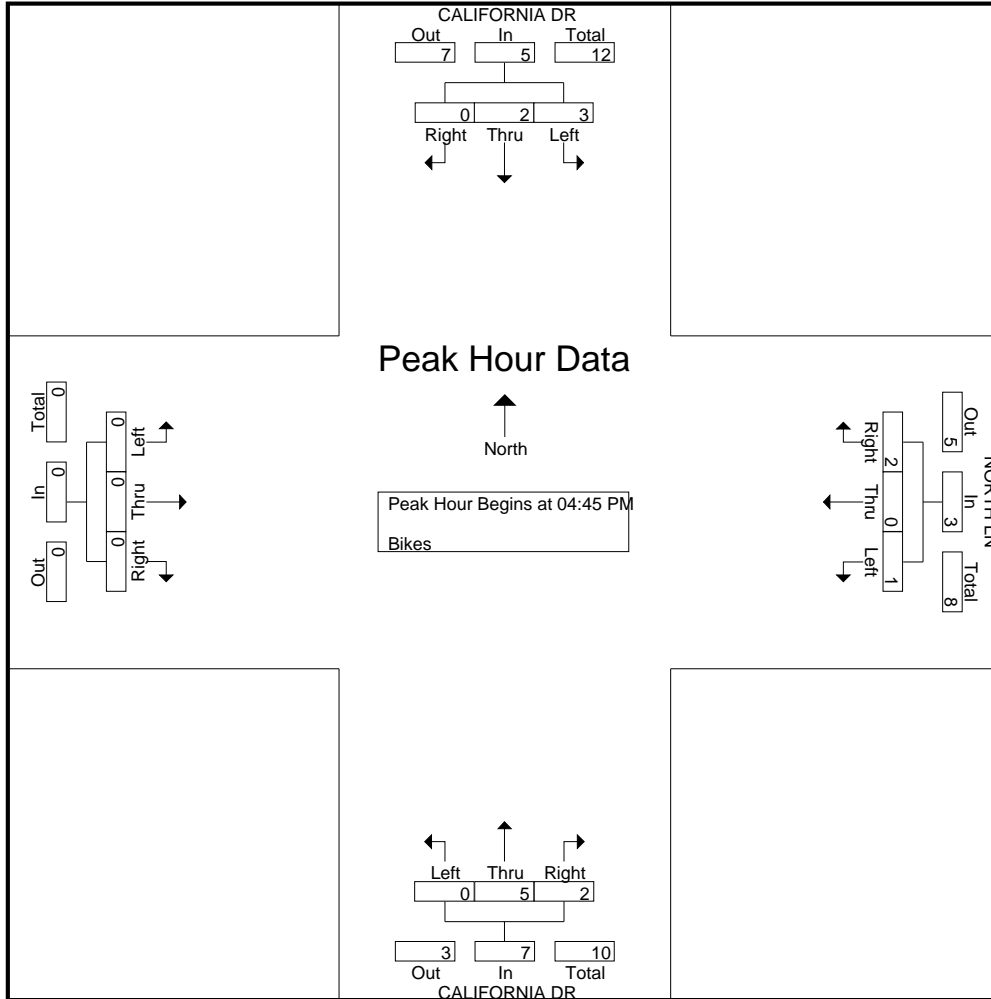

All Traffic Data

(916) 771-8700

City of Burlingame

File Name : 12-7153-005 Carolan-North

Site Code : 00000000

Start Date : 4/18/2012

Page No : 1

Groups Printed- Unshifted

Start Time	Carolan Avenue Southbound				North Lane Westbound				Carolan Avenue Northbound				North Lane Eastbound				Int. Total
	Left	Thru	Right	App. Total	Left	Thru	Right	App. Total	Left	Thru	Right	App. Total	Left	Thru	Right	App. Total	
07:00	0	8	5	13	0	0	0	0	7	6	0	13	3	0	7	10	36
07:15	0	11	9	20	0	0	0	0	13	20	0	33	13	1	12	26	79
07:30	0	16	6	22	0	0	0	0	9	19	2	30	18	0	18	36	88
07:45	0	15	0	15	0	0	0	0	18	19	1	38	20	2	22	44	97
Total	0	50	20	70	0	0	0	0	47	64	3	114	54	3	59	116	300
08:00	1	17	5	23	0	0	0	0	16	13	0	29	12	3	16	31	83
08:15	1	23	16	40	0	0	0	0	19	33	4	56	63	3	20	86	182
08:30	0	55	51	106	0	0	0	0	22	61	7	90	96	6	26	128	324
08:45	1	21	9	31	0	0	0	0	13	18	1	32	15	0	23	38	101
Total	3	116	81	200	0	0	0	0	70	125	12	207	186	12	85	283	690
16:00	1	26	8	35	0	0	0	0	19	23	0	42	21	1	24	46	123
16:15	1	35	10	46	0	0	0	0	16	25	3	44	13	0	27	40	130
16:30	1	40	21	62	0	0	0	0	23	17	2	42	14	1	28	43	147
16:45	3	36	28	67	0	0	0	0	30	40	1	71	12	2	33	47	185
Total	6	137	67	210	0	0	0	0	88	105	6	199	60	4	112	176	585
17:00	0	45	17	62	0	0	0	0	21	22	3	46	11	1	29	41	149
17:15	0	34	11	45	0	0	0	0	15	28	1	44	11	2	24	37	126
17:30	0	39	13	52	0	0	0	0	21	24	3	48	17	0	26	43	143
17:45	0	10	6	16	0	0	0	0	13	13	0	26	10	0	11	21	63
Total	0	128	47	175	0	0	0	0	70	87	7	164	49	3	90	142	481
Grand Total	9	431	215	655	0	0	0	0	275	381	28	684	349	22	346	717	2056
Apprch %	1.4	65.8	32.8		0	0	0		40.2	55.7	4.1		48.7	3.1	48.3		
Total %	0.4	21	10.5	31.9	0	0	0		13.4	18.5	1.4	33.3	17	1.1	16.8	34.9	

Start Time	Carolan Avenue Southbound				North Lane Westbound				Carolan Avenue Northbound				North Lane Eastbound				Int. Total
	Left	Thru	Right	App. Total	Left	Thru	Right	App. Total	Left	Thru	Right	App. Total	Left	Thru	Right	App. Total	
Peak Hour Analysis From 07:00 to 08:45 - Peak 1 of 1																	
Peak Hour for Entire Intersection Begins at 08:00																	
08:00	1	17	5	23	0	0	0	0	16	13	0	29	12	3	16	31	83
08:15	1	23	16	40	0	0	0	0	19	33	4	56	63	3	20	86	182
08:30	0	55	51	106	0	0	0	0	22	61	7	90	96	6	26	128	324
08:45	1	21	9	31	0	0	0	0	13	18	1	32	15	0	23	38	101
Total Volume	3	116	81	200	0	0	0	0	70	125	12	207	186	12	85	283	690
% App. Total	1.5	58	40.5		0	0	0		33.8	60.4	5.8		65.7	4.2	30		

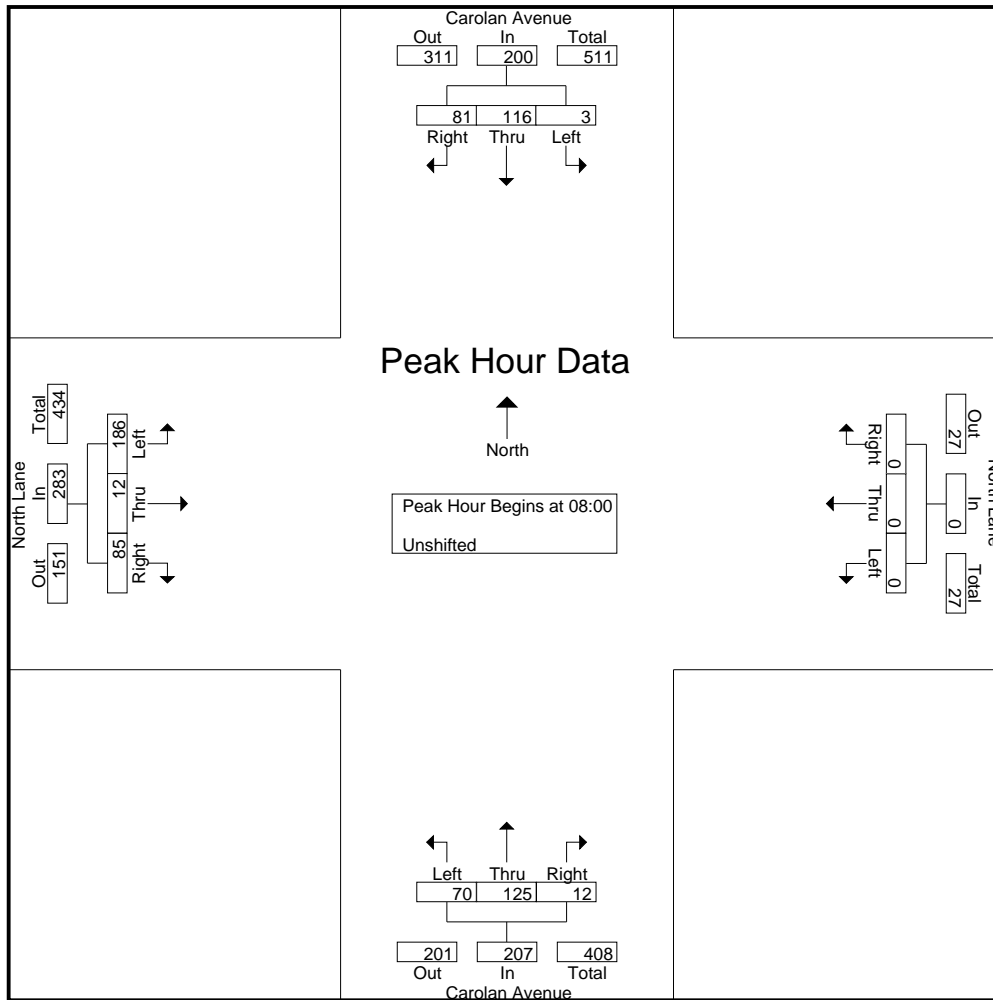

Peak Hour Analysis From 16:00 to 17:45 - Peak 1 of 1
Peak Hour for Entire Intersection Begins at 16:15

16:15	1	35	10	46	0	0	0	0	16	25	3	44	13	0	27	40	130
16:30	1	40	21	62	0	0	0	0	23	17	2	42	14	1	28	43	147
16:45	3	36	28	67	0	0	0	0	30	40	1	71	12	2	33	47	185
17:00	0	45	17	62	0	0	0	0	21	22	3	46	11	1	29	41	149
Total Volume	5	156	76	237	0	0	0	0	90	104	9	203	50	4	117	171	611
% App. Total	2.1	65.8	32.1		0	0	0		44.3	51.2	4.4		29.2	2.3	68.4		
PHF	.417	.867	.679	.884	.000	.000	.000	.000	.750	.650	.750	.715	.893	.500	.886	.910	.826

All Traffic Data

(916) 771-8700

City of Burlingame

File Name : 12-7153-005 Carolan-North

Site Code : 00000000

Start Date : 4/18/2012

Page No : 3

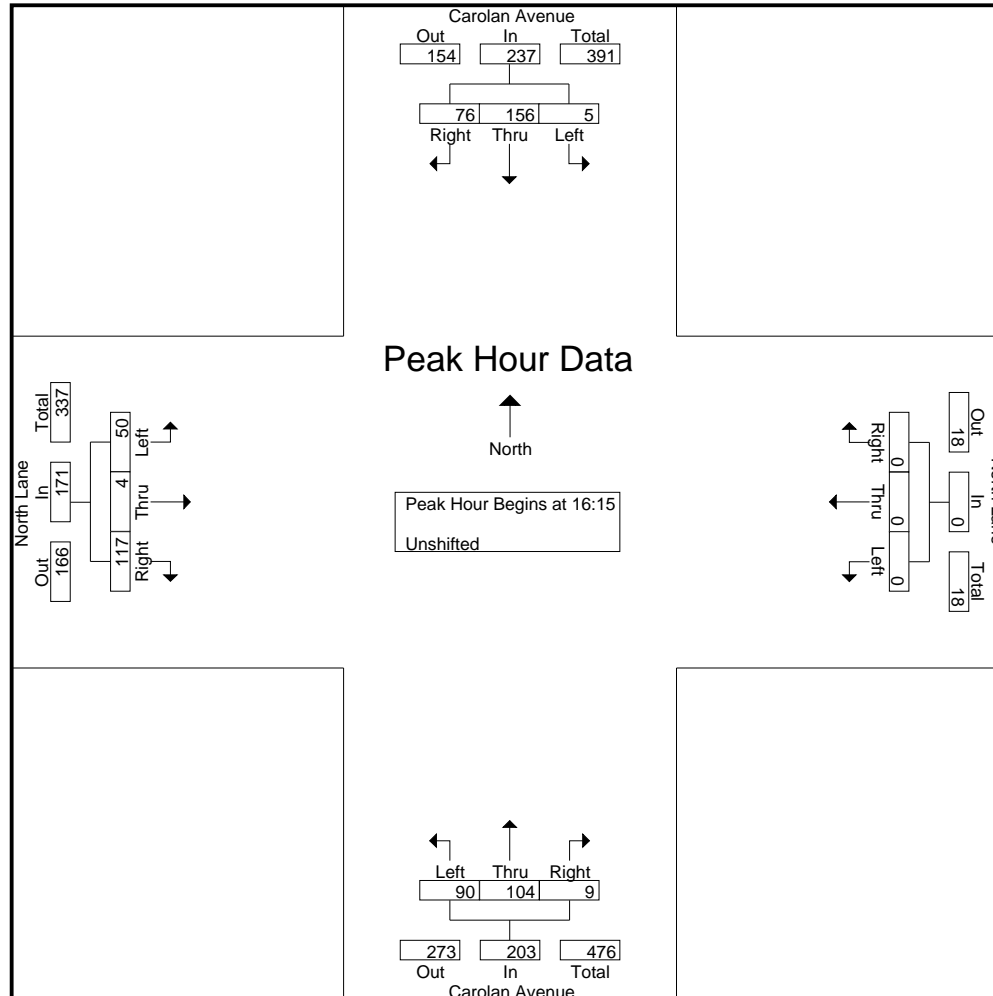

INTERSECTION CAR/PED/BIKE TRAFFIC COUNT RESULTS SUMMARY

CLIENT: FEHR & PEERS
 PROJECT: CALTRAIN TRAFFIC COUNTS
 DATE: WEDNESDAY MAY 22, 2013
 PERIOD: 7:00 AM TO 9:00 AM
 INTERSECTION: N/S ANITA AVENUE
 E/W PENINSULAR AVENUE
 CITY: SAN FRANCISCO

VEHICLE COUNTS													
15 MIN COUNTS	1	2	3	4	5	6	7	8	9	10	11	12	
PERIOD	SBRT	SBTH	SBLT	WBRT	WBTH	WBLT	NBRT	NBTH	NBLT	EBRT	EBTH	EBLT	TOTAL
700-715	0	0	4	13	65	0	0	0	0	0	107	1	190
715-730	3	0	1	7	95	0	0	0	0	0	100	1	207
730-745	0	0	9	2	109	0	0	0	0	0	117	1	238
745-800	2	0	6	7	126	0	0	0	0	0	140	3	284
800-815	2	0	8	5	142	0	0	0	0	0	134	2	293
815-830	6	0	5	9	127	0	0	0	0	0	129	5	281
830-845	2	0	5	7	112	0	0	0	0	0	129	0	255
845-900	4	0	3	14	181	0	0	0	0	0	148	1	351
HOUR TOTALS	1	2	3	4	5	6	7	8	9	10	11	12	
PERIOD	SBRT	SBTH	SBLT	WBRT	WBTH	WBLT	NBRT	NBTH	NBLT	EBRT	EBTH	EBLT	TOTAL
700-800	5	0	20	29	395	0	0	0	0	0	464	6	919
715-815	7	0	24	21	472	0	0	0	0	0	491	7	1022
730-830	10	0	28	23	504	0	0	0	0	0	520	11	1096
745-845	12	0	24	28	507	0	0	0	0	0	532	10	1113
800-900	14	0	21	35	562	0	0	0	0	0	540	8	1180

AM PEAK HOUR: 800-900

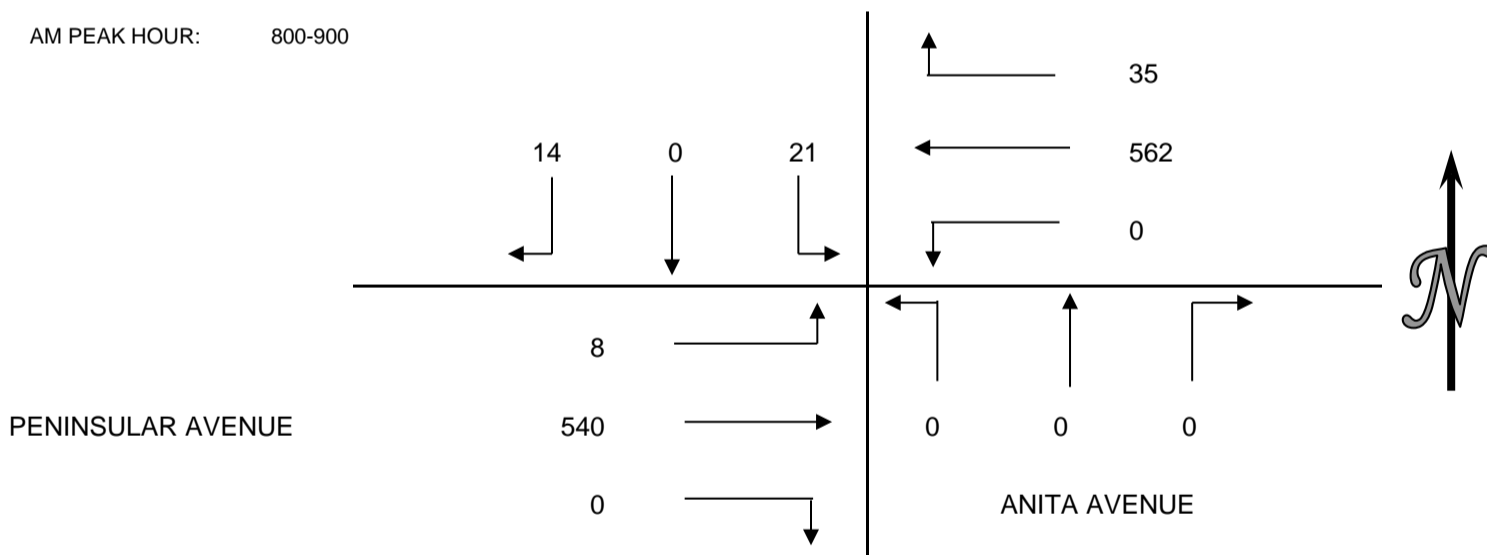

PEDESTRIAN COUNTS					
15 MIN COUNTS	NORTH LEG	EAST LEG	SOUTH LEG	WEST LEG	TOTAL
PERIOD	LEG	LEG	LEG	LEG	
700-715	2	1	0	0	3
715-730	1	2	0	1	4
730-745	5	1	0	1	7
745-800	3	2	0	0	5
800-815	2	0	0	1	3
815-830	0	0	0	0	0
830-845	2	0	0	0	2
845-900	3	0	0	0	3
HOUR TOTALS	NORTH LEG	EAST LEG	SOUTH LEG	WEST LEG	TOTAL
PERIOD	LEG	LEG	LEG	LEG	
700-800	11	6	0	2	19
715-815	11	5	0	3	19
730-830	10	3	0	2	15
745-845	7	2	0	1	10
800-900	7	0	0	1	8

BICYCLE COUNTS					
15 MIN COUNTS	NORTH LEG	EAST LEG	SOUTH LEG	WEST LEG	TOTAL
PERIOD	LEG	LEG	LEG	LEG	
700-715	0	0	0	0	0
715-730	0	0	0	0	0
730-745	0	0	0	0	0
745-800	3	0	0	0	3
800-815	0	0	0	0	0
815-830	0	0	0	0	0
830-845	2	0	0	0	2
845-900	0	0	0	0	0
HOUR TOTALS	NORTH LEG	EAST LEG	SOUTH LEG	WEST LEG	TOTAL
PERIOD	LEG	LEG	LEG	LEG	
700-800	3	0	0	0	3
715-815	3	0	0	0	3
730-830	3	0	0	0	3
745-845	5	0	0	0	5
800-900	2	0	0	0	2

INTERSECTION CAR/PED/BIKE TRAFFIC COUNT RESULTS SUMMARY

CLIENT: FEHR & PEERS
 PROJECT: CALTRAIN TRAFFIC COUNTS
 DATE: WEDNESDAY MAY 22, 2013
 PERIOD: 4:00 PM TO 6:00 PM
 INTERSECTION: N/S ANITA ROAD
 E/W PENINSULAR AVENUE
 CITY: BURLINGAME

VEHICLE COUNTS													
15 MIN COUNTS	1	2	3	4	5	6	7	8	9	10	11	12	
PERIOD	SBRT	SBTH	SBLT	WBRT	WBTH	WBLT	NBRT	NBTH	NBLT	EBRT	EBTH	EBLT	TOTAL
400-415	1	0	4	7	124	0	0	0	0	0	136	0	272
415-430	7	0	11	8	152	0	0	0	0	0	127	2	307
430-445	4	0	6	10	136	0	0	0	0	0	103	0	259
445-500	3	0	6	7	126	0	0	0	0	0	119	5	266
500-515	5	0	6	4	152	0	0	0	0	0	137	2	306
515-530	0	0	5	9	155	0	0	0	0	0	150	2	321
530-545	1	0	5	2	158	0	0	0	0	0	153	3	322
545-600	0	0	1	0	144	0	0	0	0	0	157	3	305
HOUR TOTALS	1	2	3	4	5	6	7	8	9	10	11	12	
PERIOD	SBRT	SBTH	SBLT	WBRT	WBTH	WBLT	NBRT	NBTH	NBLT	EBRT	EBTH	EBLT	TOTAL
400-500	15	0	27	32	538	0	0	0	0	0	485	7	1104
415-515	19	0	29	29	566	0	0	0	0	0	486	9	1138
430-530	12	0	23	30	569	0	0	0	0	0	509	9	1152
445-545	9	0	22	22	591	0	0	0	0	0	559	12	1215
500-600	6	0	17	15	609	0	0	0	0	0	597	10	1254

AM PEAK HOUR: 500-600

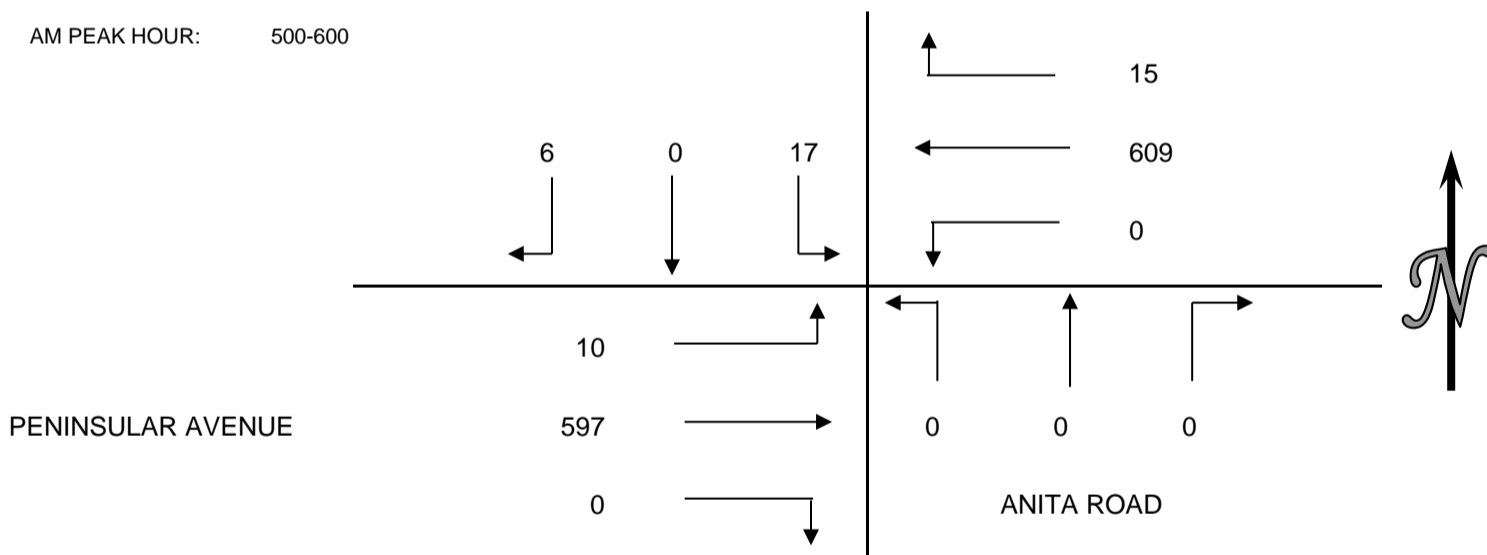

PEDESTRIAN COUNTS					
15 MIN COUNTS	NORTH LEG	EAST LEG	SOUTH LEG	WEST LEG	TOTAL
PERIOD	LEG	LEG	LEG	LEG	
400-415	2	1	0	0	3
415-430	2	1	0	0	3
430-445	3	2	0	3	8
445-500	1	0	0	0	1
500-515	5	2	0	2	9
515-530	2	2	0	1	5
530-545	3	0	0	2	5
545-600	3	3	0	1	7
HOUR TOTALS	NORTH LEG	EAST LEG	SOUTH LEG	WEST LEG	TOTAL
PERIOD	LEG	LEG	LEG	LEG	
400-500	8	4	0	3	15
415-515	11	5	0	5	21
430-530	11	6	0	6	23
445-545	11	4	0	5	20
500-600	13	7	0	6	26

BICYCLE COUNTS					
15 MIN COUNTS	NORTH LEG	EAST LEG	SOUTH LEG	WEST LEG	TOTAL
PERIOD	LEG	LEG	LEG	LEG	
400-415	0	0	0	0	0
415-430	0	0	0	0	0
430-445	0	0	0	0	0
445-500	0	0	0	0	0
500-515	0	0	0	0	0
515-530	0	0	0	0	0
530-545	1	0	0	0	1
545-600	0	0	0	0	0
HOUR TOTALS	NORTH LEG	EAST LEG	SOUTH LEG	WEST LEG	TOTAL
PERIOD	LEG	LEG	LEG	LEG	
400-500	0	0	0	0	0
415-515	0	0	0	0	0
430-530	0	0	0	0	0
445-545	1	0	0	0	1
500-600	1	0	0	0	1

All Traffic Data

(916) 771-8700

City of San Mateo

File Name : 12-7153-014 Woodside-Villa Terrace

Site Code : 00000000

Start Date : 4/18/2012

Page No : 1

Groups Printed- Unshifted

Start Time	Woodside Way Southbound				Villa Terrace Westbound				Woodside Way Northbound				Villa Terrace Eastbound				Int. Total
	Left	Thru	Right	App. Total	Left	Thru	Right	App. Total	Left	Thru	Right	App. Total	Left	Thru	Right	App. Total	
07:00	0	4	7	11	0	0	0	0	0	4	0	4	1	3	1	5	20
07:15	1	1	6	8	0	2	3	5	5	3	0	8	3	3	1	7	28
07:30	0	2	8	10	0	7	0	7	0	2	0	2	4	3	0	7	26
07:45	0	7	14	21	0	2	2	4	3	3	0	6	6	3	2	11	42
Total	1	14	35	50	0	11	5	16	8	12	0	20	14	12	4	30	116
08:00	1	3	15	19	0	2	0	2	2	4	1	7	14	4	2	20	48
08:15	0	2	16	18	1	5	3	9	1	4	0	5	11	3	2	16	48
08:30	1	2	7	10	0	2	3	5	0	1	2	3	4	6	0	10	28
08:45	1	3	8	12	1	6	3	10	0	4	0	4	4	3	4	11	37
Total	3	10	46	59	2	15	9	26	3	13	3	19	33	16	8	57	161
16:00	1	6	5	12	0	2	1	3	0	1	1	2	4	4	0	8	25
16:15	1	3	8	12	0	4	2	6	2	3	0	5	2	7	1	10	33
16:30	1	5	7	13	1	2	1	4	0	0	3	3	2	9	1	12	32
16:45	0	10	9	19	1	7	1	9	1	1	1	3	5	9	1	15	46
Total	3	24	29	56	2	15	5	22	3	5	5	13	13	29	3	45	136
17:00	0	5	5	10	1	8	1	10	1	0	0	1	5	9	2	16	37
17:15	2	5	7	14	0	5	0	5	0	2	2	4	2	3	2	7	30
17:30	2	1	10	13	1	8	1	10	2	1	3	6	3	5	5	13	42
17:45	1	5	5	11	0	1	3	4	0	2	2	4	3	2	1	6	25
Total	5	16	27	48	2	22	5	29	3	5	7	15	13	19	10	42	134
Grand Total	12	64	137	213	6	63	24	93	17	35	15	67	73	76	25	174	547
Apprch %	5.6	30	64.3		6.5	67.7	25.8		25.4	52.2	22.4		42	43.7	14.4		
Total %	2.2	11.7	25	38.9	1.1	11.5	4.4	17	3.1	6.4	2.7	12.2	13.3	13.9	4.6	31.8	

Start Time	Woodside Way Southbound				Villa Terrace Westbound				Woodside Way Northbound				Villa Terrace Eastbound				Int. Total
	Left	Thru	Right	App. Total	Left	Thru	Right	App. Total	Left	Thru	Right	App. Total	Left	Thru	Right	App. Total	
Peak Hour Analysis From 07:00 to 08:45 - Peak 1 of 1																	
Peak Hour for Entire Intersection Begins at 07:45																	
07:45	0	7	14	21	0	2	2	4	3	3	0	6	6	3	2	11	42
08:00	1	3	15	19	0	2	0	2	2	4	1	7	14	4	2	20	48
08:15	0	2	16	18	1	5	3	9	1	4	0	5	11	3	2	16	48
08:30	1	2	7	10	0	2	3	5	0	1	2	3	4	6	0	10	28
Total Volume	2	14	52	68	1	11	8	20	6	12	3	21	35	16	6	57	166
% App. Total	2.9	20.6	76.5		5	55	40		28.6	57.1	14.3		61.4	28.1	10.5		

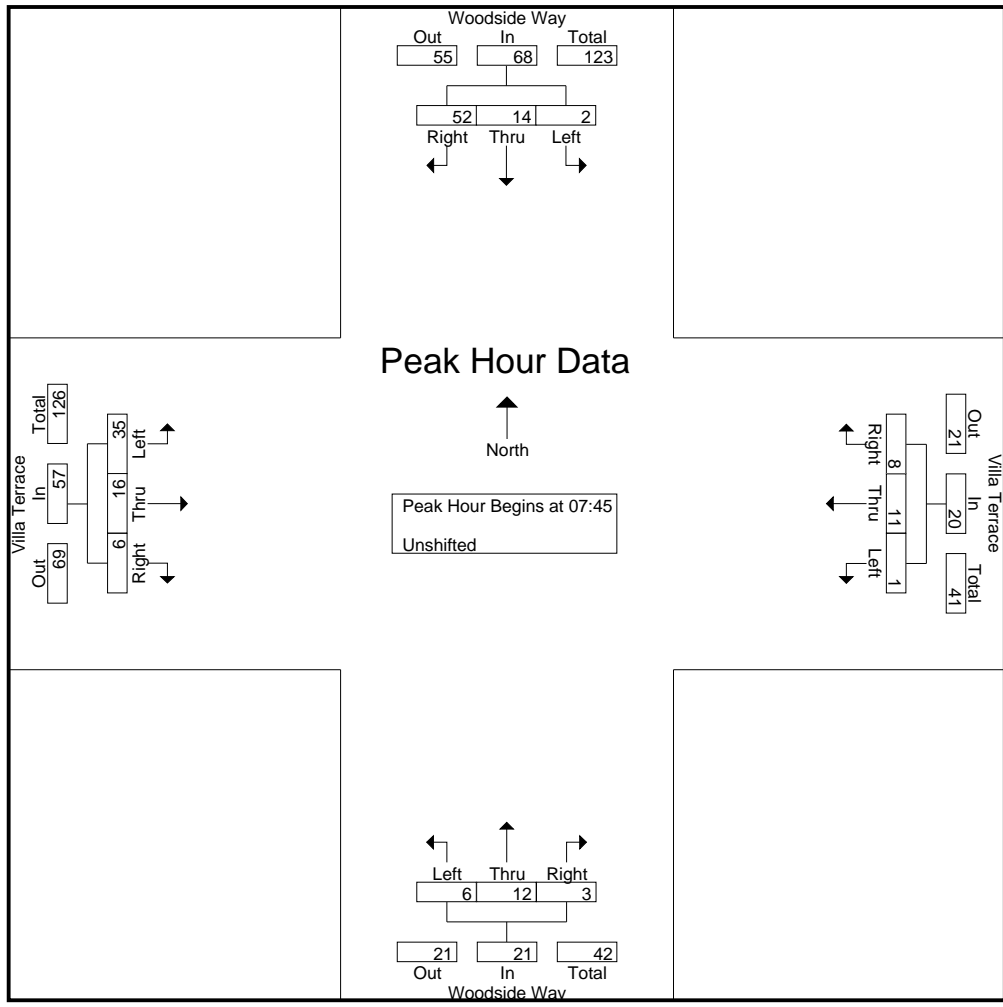

Peak Hour Analysis From 16:00 to 17:45 - Peak 1 of 1
 Peak Hour for Entire Intersection Begins at 16:45

16:45	0	10	9	19	1	7	1	9	1	1	1	3	5	9	1	15	46
17:00	0	5	5	10	1	8	1	10	1	0	0	1	5	9	2	16	37
17:15	2	5	7	14	0	5	0	5	0	2	2	4	2	3	2	7	30
17:30	2	1	10	13	1	8	1	10	2	1	3	6	3	5	5	13	42
Total Volume	4	21	31	56	3	28	3	34	4	4	6	14	15	26	10	51	155
% App. Total	7.1	37.5	55.4		8.8	82.4	8.8		28.6	28.6	42.9		29.4	51	19.6		
PHF	.500	.525	.775	.737	.750	.875	.750	.850	.500	.500	.500	.583	.750	.722	.500	.797	.842

All Traffic Data

(916) 771-8700

City of San Mateo

File Name : 12-7153-014 Woodside-Villa Terrace

Site Code : 00000000

Start Date : 4/18/2012

Page No : 3

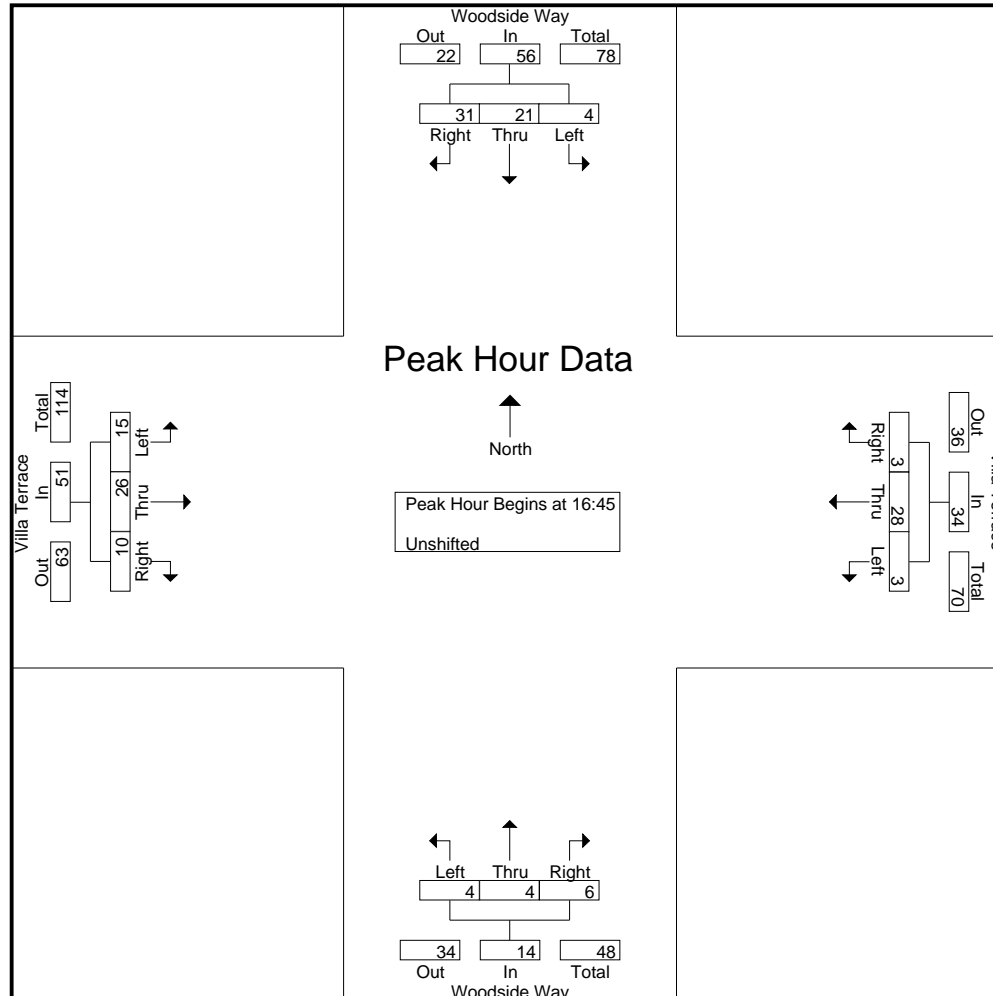

Traffic Data Service

Campbell, CA
 (408) 377-2988
 tdsbay@cs.com

File Name : 36AM FINAL
 Site Code : 00000036
 Start Date : 6/4/2013
 Page No : 1

Groups Printed- Vehicles

Start Time	N. SAN MATEO DR Southbound					VILLA TERRACE Westbound					N. SAN MATEO DR Northbound					VILLA TERRACE Eastbound					Int. Total
	Right	Thru	Left	Peds	App. Total	Right	Thru	Left	Peds	App. Total	Right	Thru	Left	Peds	App. Total	Right	Thru	Left	Peds	App. Total	
07:00 AM	0	45	1	1	47	1	1	5	2	9	2	53	0	2	57	5	0	3	0	8	121
07:15 AM	1	49	2	0	52	4	1	3	0	8	4	72	0	1	77	1	1	4	4	10	147
07:30 AM	2	103	2	0	107	3	1	9	1	14	9	87	0	0	96	2	1	2	1	6	223
07:45 AM	2	141	1	4	148	3	2	10	2	17	8	113	4	4	129	0	2	1	0	3	297
Total	5	338	6	5	354	11	5	27	5	48	23	325	4	7	359	8	4	10	5	27	788
08:00 AM	2	108	1	2	113	2	7	10	2	21	11	116	4	0	131	3	1	2	6	12	277
08:15 AM	4	112	4	1	121	8	8	8	1	25	6	100	3	1	110	2	0	3	3	8	264
08:30 AM	6	128	4	2	140	6	2	6	0	14	7	93	4	0	104	7	0	3	2	12	270
08:45 AM	11	126	2	0	139	4	0	5	3	12	6	103	4	0	113	2	0	3	1	6	270
Total	23	474	11	5	513	20	17	29	6	72	30	412	15	1	458	14	1	11	12	38	1081
Grand Total	28	812	17	10	867	31	22	56	11	120	53	737	19	8	817	22	5	21	17	65	1869
Apprch %	3.2	93.7	2	1.2		25.8	18.3	46.7	9.2		6.5	90.2	2.3	1		33.8	7.7	32.3	26.2		
Total %	1.5	43.4	0.9	0.5	46.4	1.7	1.2	3	0.6	6.4	2.8	39.4	1	0.4	43.7	1.2	0.3	1.1	0.9	3.5	

Start Time	N. SAN MATEO DR Southbound					VILLA TERRACE Westbound					N. SAN MATEO DR Northbound					VILLA TERRACE Eastbound					Int. Total
	Right	Thru	Left	Peds	App. Total	Right	Thru	Left	Peds	App. Total	Right	Thru	Left	Peds	App. Total	Right	Thru	Left	Peds	App. Total	
07:45 AM	2	141	1		144	3	2	10		15	8	113	4		125	0	2	1		3	287
08:00 AM	2	108	1		111	2	7	10		19	11	116	4		131	3	1	2		6	267
08:15 AM	4	112	4		120	8	8	8		24	6	100	3		109	2	0	3		5	258
08:30 AM	6	128	4		138	6	2	6		14	7	93	4		104	7	0	3		10	266
Total Volume	14	489	10		513	19	19	34		72	32	422	15		469	12	3	9		24	1078
% App. Total	2.7	95.3	1.9			26.4	26.4	47.2			6.8	90	3.2			50	12.5	37.5			
PHF	.583	.867	.625		.891	.594	.594	.850		.750	.727	.909	.938		.895	.429	.375	.750		.600	.939

Peak Hour Analysis From 07:00 AM to 08:45 AM - Peak 1 of 1

Peak Hour for Entire Intersection Begins at 07:45 AM

Traffic Data Service

Campbell, CA

(408) 377-2988

tdsbay@cs.com

File Name : 36AM FINAL

Site Code : 00000036

Start Date : 6/4/2013

Page No : 2

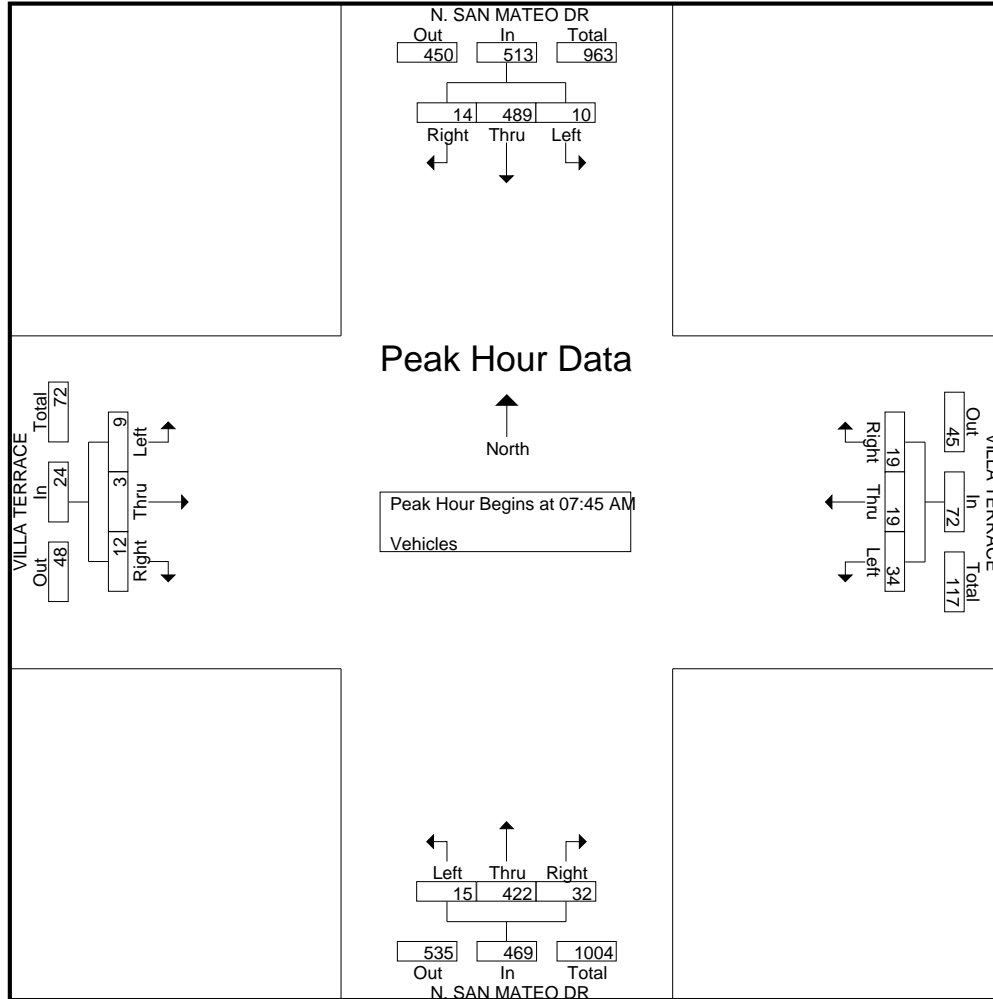

Traffic Data Service

Campbell, CA
 (408) 377-2988
 tdsbay@cs.com

File Name : 36AM FINAL
 Site Code : 00000036
 Start Date : 6/4/2013
 Page No : 1

Groups Printed- Bikes

Start Time	N. SAN MATEO DR Southbound					VILLA TERRACE Westbound					N. SAN MATEO DR Northbound					VILLA TERRACE Eastbound					Int. Total	
	Right	Thru	Left	Peds	App. Total	Right	Thru	Left	Peds	App. Total	Right	Thru	Left	Peds	App. Total	Right	Thru	Left	Peds	App. Total		
07:00 AM	0	2	0	0	2	0	0	0	0	0	0	0	0	0	0	0	0	0	0	0	0	2
07:15 AM	0	2	0	0	2	0	0	0	0	0	0	0	0	0	0	0	0	0	0	0	0	2
07:30 AM	0	0	0	0	0	0	0	0	0	0	0	3	0	0	3	0	0	0	0	0	0	3
07:45 AM	0	3	0	0	3	0	0	0	0	0	0	1	0	0	1	0	0	0	0	0	0	4
Total	0	7	0	0	7	0	0	0	0	0	0	4	0	0	4	0	0	0	0	0	0	11
08:00 AM	0	0	0	0	0	0	0	0	0	0	0	2	0	0	2	0	0	0	0	0	0	2
08:15 AM	0	0	0	0	0	0	0	0	0	0	0	1	0	0	1	0	0	0	0	0	0	1
08:30 AM	0	4	0	0	4	0	0	0	0	0	0	2	0	0	2	0	0	0	0	0	0	6
08:45 AM	0	2	0	0	2	0	0	0	0	0	0	2	0	0	2	0	0	0	0	0	0	4
Total	0	6	0	0	6	0	0	0	0	0	0	7	0	0	7	0	0	0	0	0	0	13
Grand Total	0	13	0	0	13	0	0	0	0	0	0	11	0	0	11	0	0	0	0	0	0	24
Apprch %	0	100	0	0		0	0	0	0		0	100	0	0		0	0	0	0			
Total %	0	54.2	0	0	54.2	0	0	0	0	0	0	45.8	0	0	45.8	0	0	0	0	0	0	

Start Time	N. SAN MATEO DR Southbound					VILLA TERRACE Westbound					N. SAN MATEO DR Northbound					VILLA TERRACE Eastbound					Int. Total	
	Right	Thru	Left	Peds	App. Total	Right	Thru	Left	Peds	App. Total	Right	Thru	Left	Peds	App. Total	Right	Thru	Left	Peds	App. Total		
07:45 AM	0	3	0	0	3	0	0	0	0	0	0	1	0	1	0	0	0	0	0	0	0	4
08:00 AM	0	0	0	0	0	0	0	0	0	0	0	2	0	2	0	0	0	0	0	0	0	2
08:15 AM	0	0	0	0	0	0	0	0	0	0	0	1	0	1	0	0	0	0	0	0	0	1
08:30 AM	0	4	0	0	4	0	0	0	0	0	0	2	0	2	0	0	0	0	0	0	0	6
Total Volume	0	7	0	0	7	0	0	0	0	0	0	6	0	6	0	0	0	0	0	0	0	13
% App. Total	0	100	0	0		0	0	0	0		0	100	0	0		0	0	0	0			
PHF	.000	.438	.000	.000	.438	.000	.000	.000	.000	.000	.000	.750	.000	.750	.000	.000	.000	.000	.000	.000	.000	.542

Peak Hour Analysis From 07:00 AM to 08:45 AM - Peak 1 of 1

Peak Hour for Entire Intersection Begins at 07:45 AM

Traffic Data Service

Campbell, CA

(408) 377-2988

tdsbay@cs.com

File Name : 36AM FINAL

Site Code : 00000036

Start Date : 6/4/2013

Page No : 2

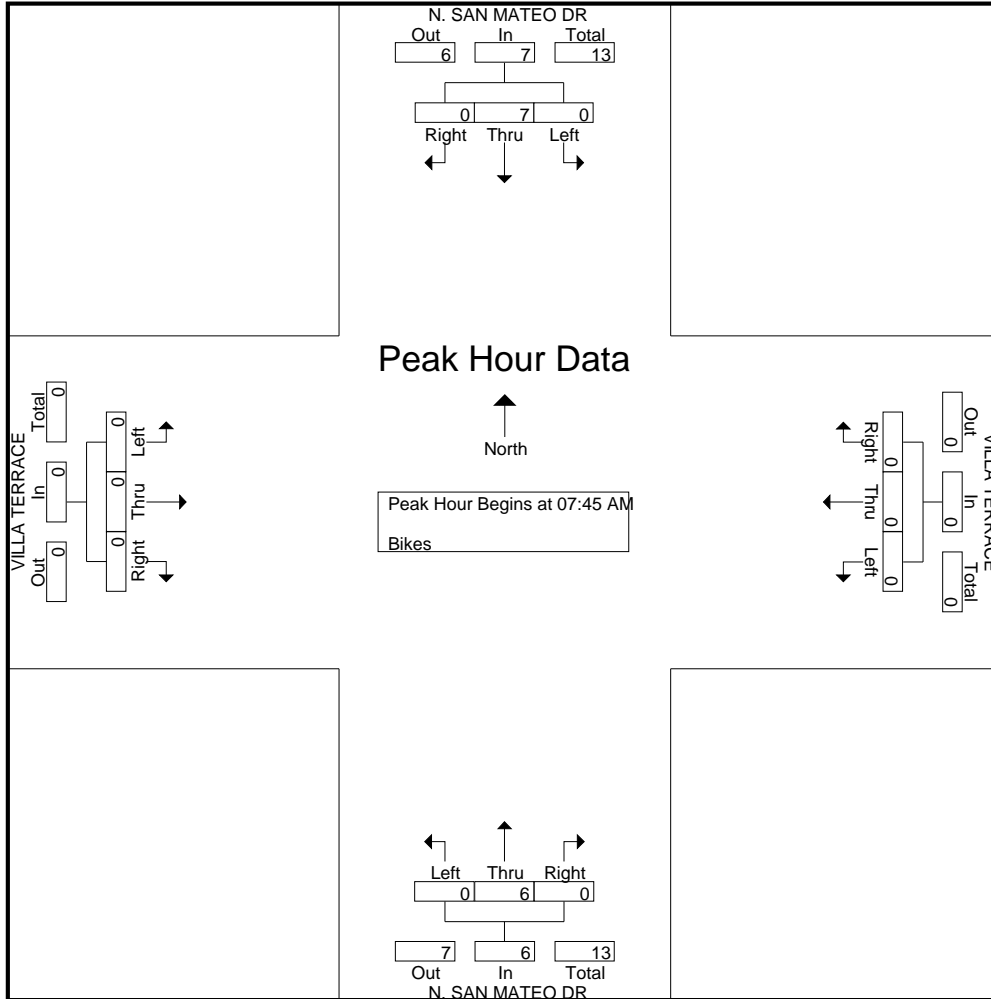

Traffic Data Service

Campbell, CA
 (408) 377-2988
 tdsbay@cs.com

File Name : 36PM FINAL
 Site Code : 00000036
 Start Date : 6/4/2013
 Page No : 1

Groups Printed- Bikes

Start Time	N. SAN MATEO DR Southbound					VILLA TERRACE Westbound					N. SAN MATEO DR Northbound					VILLA TERRACE Eastbound					Int. Total
	Right	Thru	Left	Peds	App. Total	Right	Thru	Left	Peds	App. Total	Right	Thru	Left	Peds	App. Total	Right	Thru	Left	Peds	App. Total	
04:00 PM	0	0	0	0	0	0	0	0	0	0	0	1	0	0	1	0	0	0	0	0	0
04:15 PM	0	0	0	0	0	0	0	0	0	0	0	1	0	0	1	0	0	0	0	0	0
04:30 PM	0	0	0	0	0	0	0	0	0	0	0	0	0	0	0	0	0	0	0	0	0
04:45 PM	0	0	0	0	0	0	0	0	0	0	0	3	0	0	3	0	0	0	0	0	0
Total	0	0	0	0	0	0	0	0	0	0	0	5	0	0	5	0	0	0	0	0	0
05:00 PM	0	1	0	0	1	0	0	0	0	0	0	3	0	0	3	0	0	0	0	0	0
05:15 PM	0	3	0	0	3	0	0	0	0	0	0	1	0	0	1	0	0	0	0	0	0
05:30 PM	0	5	0	0	5	0	0	0	0	0	0	1	0	0	1	0	0	0	0	0	0
05:45 PM	0	1	0	0	1	0	0	0	0	0	0	1	0	0	1	0	0	0	0	0	0
Total	0	10	0	0	10	0	0	0	0	0	0	6	0	0	6	0	0	0	0	0	0
Grand Total	0	10	0	0	10	0	0	0	0	0	0	11	0	0	11	0	0	0	0	0	0
Apprch %	0	100	0	0		0	0	0	0		0	100	0	0		0	0	0	0		
Total %	0	47.6	0	0	47.6	0	0	0	0	0	0	52.4	0	0	52.4	0	0	0	0	0	0

Start Time	N. SAN MATEO DR Southbound				VILLA TERRACE Westbound				N. SAN MATEO DR Northbound				VILLA TERRACE Eastbound				Int. Total
	Right	Thru	Left	App. Total	Right	Thru	Left	App. Total	Right	Thru	Left	App. Total	Right	Thru	Left	App. Total	
04:45 PM	0	0	0	0	0	0	0	0	0	3	0	3	0	0	0	0	3
05:00 PM	0	1	0	1	0	0	0	0	0	3	0	3	0	0	0	0	4
05:15 PM	0	3	0	3	0	0	0	0	0	1	0	1	0	0	0	0	4
05:30 PM	0	5	0	5	0	0	0	0	0	1	0	1	0	0	0	0	6
Total Volume	0	9	0	9	0	0	0	0	0	8	0	8	0	0	0	0	17
% App. Total	0	100	0		0	0	0		0	100	0		0	0	0		
PHF	.000	.450	.000	.450	.000	.000	.000	.000	.000	.667	.000	.667	.000	.000	.000	.000	.708

Peak Hour Analysis From 04:00 PM to 05:45 PM - Peak 1 of 1

Peak Hour for Entire Intersection Begins at 04:45 PM

Traffic Data Service

Campbell, CA

(408) 377-2988

tdsbay@cs.com

File Name : 36PM FINAL

Site Code : 00000036

Start Date : 6/4/2013

Page No : 2

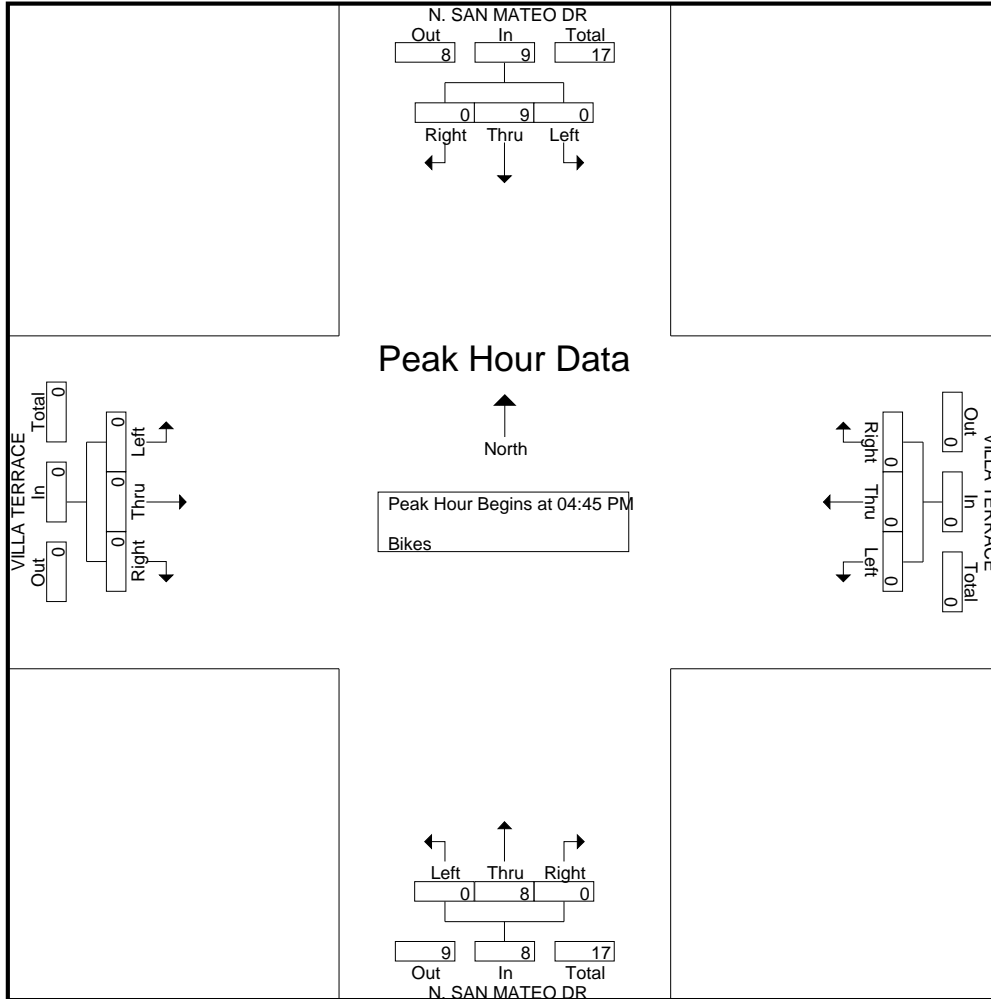

INTERSECTION CAR/PED/BIKE TRAFFIC COUNT RESULTS SUMMARY

CLIENT: FEHR & PEERS
 PROJECT: CALTRAIN TRAFFIC COUNTS
 DATE: WEDNESDAY MAY 22, 2013
 PERIOD: 7:00 AM TO 9:00 AM
 INTERSECTION: N/S RAILROAD AVENUE
 E/W 1ST AVENUE
 CITY: SAN MATEO

VEHICLE COUNTS													
15 MIN COUNTS	1	2	3	4	5	6	7	8	9	10	11	12	
PERIOD	SBRT	SBTH	SBLT	WBRT	WBTH	WBLT	NBRT	NBTH	NBLT	EBRT	EBTH	EBLT	TOTAL
700-715	1	13	1	3	17	2	3	15	5	2	8	1	71
715-730	5	16	3	5	20	4	4	17	11	7	12	0	104
730-745	2	21	1	3	26	3	2	20	8	2	10	1	99
745-800	4	33	4	1	22	3	5	22	14	5	6	1	120
800-815	2	27	2	0	29	3	5	19	8	5	10	1	111
815-830	2	19	2	0	29	3	3	13	9	3	15	2	100
830-845	1	22	1	2	26	3	3	12	6	4	13	3	96
845-900	3	12	0	2	29	2	2	17	9	11	7	1	95
HOUR TOTALS	1	2	3	4	5	6	7	8	9	10	11	12	
PERIOD	SBRT	SBTH	SBLT	WBRT	WBTH	WBLT	NBRT	NBTH	NBLT	EBRT	EBTH	EBLT	TOTAL
700-800	12	83	9	12	85	12	14	74	38	16	36	3	394
715-815	13	97	10	9	97	13	16	78	41	19	38	3	434
730-830	10	100	9	4	106	12	15	74	39	15	41	5	430
745-845	9	101	9	3	106	12	16	66	37	17	44	7	427
800-900	8	80	5	4	113	11	13	61	32	23	45	7	402

AM PEAK HOUR: 715-815

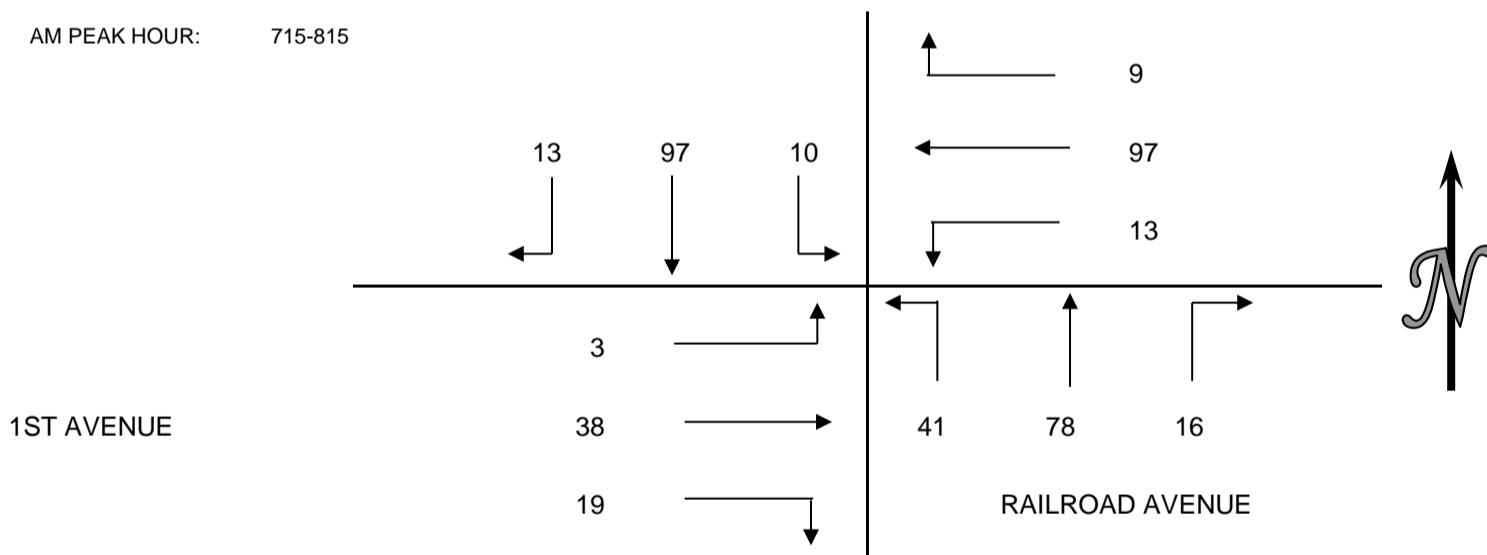

PEDESTRIAN COUNTS					
15 MIN COUNTS	NORTH LEG	EAST LEG	SOUTH LEG	WEST LEG	TOTAL
PERIOD	LEG	LEG	LEG	LEG	
700-715	6	0	2	2	10
715-730	7	2	3	1	13
730-745	15	0	5	3	23
745-800	12	1	7	4	24
800-815	9	0	1	5	15
815-830	7	1	1	3	12
830-845	9	0	2	3	14
845-900	12	1	2	12	27
HOUR TOTALS	NORTH LEG	EAST LEG	SOUTH LEG	WEST LEG	TOTAL
PERIOD	LEG	LEG	LEG	LEG	
700-800	40	3	17	10	70
715-815	43	3	16	13	75
730-830	43	2	14	15	74
745-845	37	2	11	15	65
800-900	37	2	6	23	68

BICYCLE COUNTS					
15 MIN COUNTS	NORTH LEG	EAST LEG	SOUTH LEG	WEST LEG	TOTAL
PERIOD	LEG	LEG	LEG	LEG	
700-715	1	0	1	2	4
715-730	2	1	0	3	6
730-745	1	0	2	3	6
745-800	2	1	0	4	7
800-815	5	0	1	4	10
815-830	5	1	1	1	8
830-845	3	0	4	4	11
845-900	0	1	0	2	3
HOUR TOTALS	NORTH LEG	EAST LEG	SOUTH LEG	WEST LEG	TOTAL
PERIOD	LEG	LEG	LEG	LEG	
700-800	6	2	3	12	23
715-815	10	2	3	14	29
730-830	13	2	4	12	31
745-845	15	2	6	13	36
800-900	13	2	6	11	32

Traffic Data Service

Campbell, CA
 (408) 377-2988
 tdsbay@cs.com

File Name : 36PM FINAL
 Site Code : 00000036
 Start Date : 6/4/2013
 Page No : 1

Groups Printed- Vehicles

Start Time	N. SAN MATEO DR Southbound					VILLA TERRACE Westbound					N. SAN MATEO DR Northbound					VILLA TERRACE Eastbound					Int. Total
	Right	Thru	Left	Peds	App. Total	Right	Thru	Left	Peds	App. Total	Right	Thru	Left	Peds	App. Total	Right	Thru	Left	Peds	App. Total	
04:00 PM	3	109	2	4	118	5	1	4	4	14	8	110	0	1	119	2	0	1	2	5	256
04:15 PM	4	116	6	1	127	4	1	9	5	19	8	96	3	0	107	1	0	1	2	4	257
04:30 PM	2	113	1	0	116	2	2	4	2	10	7	137	3	0	147	3	0	1	1	5	278
04:45 PM	5	106	4	5	120	3	2	11	6	22	4	103	0	2	109	3	1	1	1	6	257
Total	14	444	13	10	481	14	6	28	17	65	27	446	6	3	482	9	1	4	6	20	1048
05:00 PM	4	126	3	2	135	3	1	9	0	13	9	142	0	0	151	0	0	0	5	5	304
05:15 PM	2	119	3	2	126	7	1	10	1	19	14	140	2	0	156	5	0	2	6	13	314
05:30 PM	3	120	8	0	131	6	1	4	1	12	5	149	5	0	159	6	0	0	5	11	313
05:45 PM	5	121	3	4	133	3	2	5	1	11	7	136	1	3	147	2	0	1	5	8	299
Total	14	486	17	8	525	19	5	28	3	55	35	567	8	3	613	13	0	3	21	37	1230
Grand Total	28	930	30	18	1006	33	11	56	20	120	62	1013	14	6	1095	22	1	7	27	57	2278
Apprch %	2.8	92.4	3	1.8		27.5	9.2	46.7	16.7		5.7	92.5	1.3	0.5		38.6	1.8	12.3	47.4		
Total %	1.2	40.8	1.3	0.8	44.2	1.4	0.5	2.5	0.9	5.3	2.7	44.5	0.6	0.3	48.1	1	0	0.3	1.2	2.5	

Start Time	N. SAN MATEO DR Southbound				VILLA TERRACE Westbound				N. SAN MATEO DR Northbound				VILLA TERRACE Eastbound				Int. Total
	Right	Thru	Left	App. Total	Right	Thru	Left	App. Total	Right	Thru	Left	App. Total	Right	Thru	Left	App. Total	
Peak Hour Analysis From 04:00 PM to 05:45 PM - Peak 1 of 1																	
Peak Hour for Entire Intersection Begins at 05:00 PM																	
05:00 PM	4	126	3	133	3	1	9	13	9	142	0	151	0	0	0	0	297
05:15 PM	2	119	3	124	7	1	10	18	14	140	2	156	5	0	2	7	305
05:30 PM	3	120	8	131	6	1	4	11	5	149	5	159	6	0	0	6	307
05:45 PM	5	121	3	129	3	2	5	10	7	136	1	144	2	0	1	3	286
Total Volume	14	486	17	517	19	5	28	52	35	567	8	610	13	0	3	16	1195
% App. Total	2.7	94	3.3		36.5	9.6	53.8		5.7	93	1.3		81.2	0	18.8		
PHF	.700	.964	.531	.972	.679	.625	.700	.722	.625	.951	.400	.959	.542	.000	.375	.571	.973

Traffic Data Service

Campbell, CA
 (408) 377-2988
 tdsbay@cs.com

File Name : 36PM FINAL
 Site Code : 00000036
 Start Date : 6/4/2013
 Page No : 2

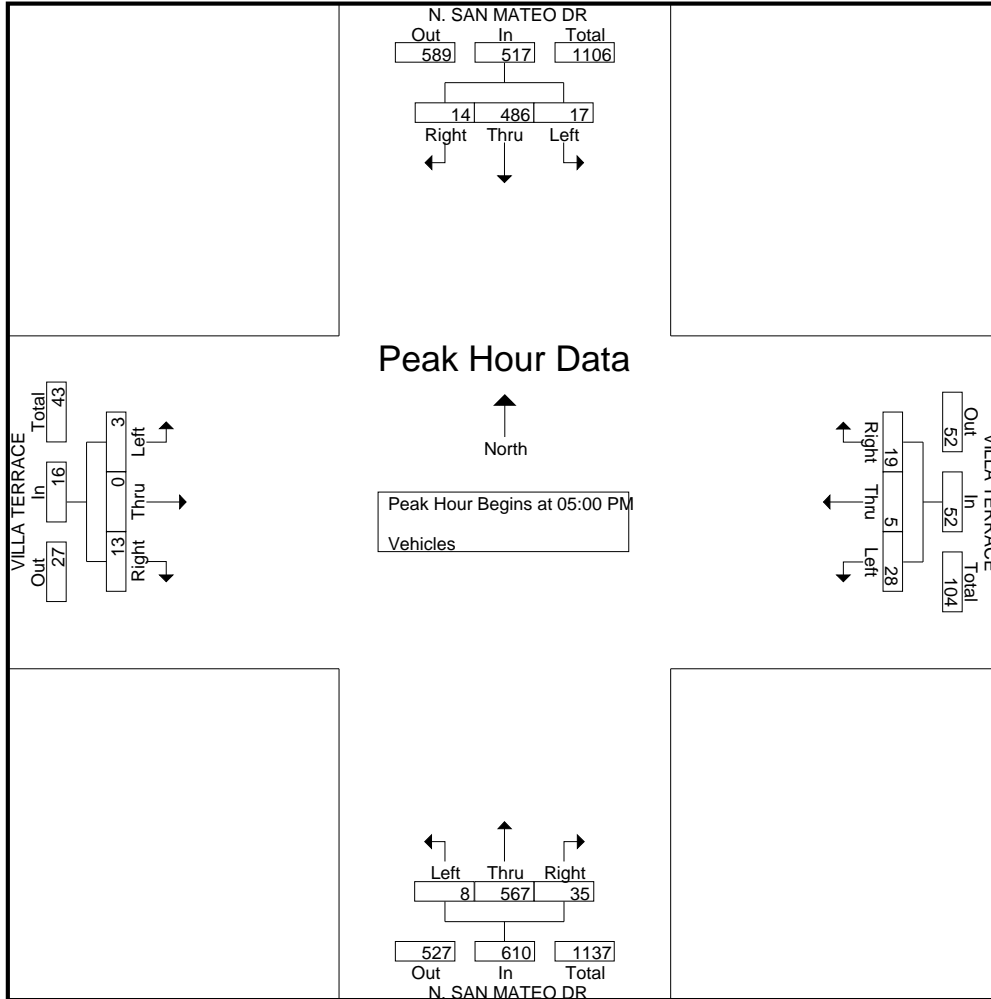

Traffic Data Service

Campbell, CA
 (408) 377-2988
 tdsbay@cs.com

File Name : 40PM FINAL
 Site Code : 00000040
 Start Date : 6/4/2013
 Page No : 1

Groups Printed- Vehicles

Start Time	S. B ST Southbound					1ST AVE Westbound					S. B ST Northbound					1ST AVE Eastbound					Int. Total
	Right	Thru	Left	Peds	App. Total	Right	Thru	Left	Peds	App. Total	Right	Thru	Left	Peds	App. Total	Right	Thru	Left	Peds	App. Total	
04:00 PM	7	36	17	21	81	13	18	4	36	71	12	48	10	26	96	12	11	2	37	62	310
04:15 PM	2	32	14	16	64	14	16	10	24	64	10	53	12	18	93	6	9	0	28	43	264
04:30 PM	1	38	16	29	84	12	11	5	47	75	11	49	9	26	95	7	8	3	41	59	313
04:45 PM	4	35	14	19	72	14	11	9	40	74	12	51	8	31	102	7	15	0	36	58	306
Total	14	141	61	85	301	53	56	28	147	284	45	201	39	101	386	32	43	5	142	222	1193
05:00 PM	4	44	19	17	84	15	13	5	48	81	8	46	6	43	103	10	18	2	44	74	342
05:15 PM	9	38	12	21	80	24	8	5	22	59	11	51	12	37	111	9	13	4	36	62	312
05:30 PM	7	29	13	51	100	17	14	3	27	61	12	42	6	22	82	7	14	1	40	62	305
05:45 PM	5	36	18	37	96	20	20	9	42	91	19	42	6	35	102	6	16	3	47	72	361
Total	25	147	62	126	360	76	55	22	139	292	50	181	30	137	398	32	61	10	167	270	1320
Grand Total	39	288	123	211	661	129	111	50	286	576	95	382	69	238	784	64	104	15	309	492	2513
Apprch %	5.9	43.6	18.6	31.9		22.4	19.3	8.7	49.7		12.1	48.7	8.8	30.4		13	21.1	3	62.8		
Total %	1.6	11.5	4.9	8.4	26.3	5.1	4.4	2	11.4	22.9	3.8	15.2	2.7	9.5	31.2	2.5	4.1	0.6	12.3	19.6	

Start Time	S. B ST Southbound				1ST AVE Westbound				S. B ST Northbound				1ST AVE Eastbound				Int. Total
	Right	Thru	Left	App. Total	Right	Thru	Left	App. Total	Right	Thru	Left	App. Total	Right	Thru	Left	App. Total	
Peak Hour Analysis From 04:00 PM to 05:45 PM - Peak 1 of 1																	
Peak Hour for Entire Intersection Begins at 05:00 PM																	
05:00 PM	4	44	19	67	15	13	5	33	8	46	6	60	10	18	2	30	190
05:15 PM	9	38	12	59	24	8	5	37	11	51	12	74	9	13	4	26	196
05:30 PM	7	29	13	49	17	14	3	34	12	42	6	60	7	14	1	22	165
05:45 PM	5	36	18	59	20	20	9	49	19	42	6	67	6	16	3	25	200
Total Volume	25	147	62	234	76	55	22	153	50	181	30	261	32	61	10	103	751
% App. Total	10.7	62.8	26.5		49.7	35.9	14.4		19.2	69.3	11.5		31.1	59.2	9.7		
PHF	.694	.835	.816	.873	.792	.688	.611	.781	.658	.887	.625	.882	.800	.847	.625	.858	.939

Traffic Data Service

Campbell, CA
(408) 377-2988
tdsbay@cs.com

File Name : 40PM FINAL
Site Code : 00000040
Start Date : 6/4/2013
Page No : 2

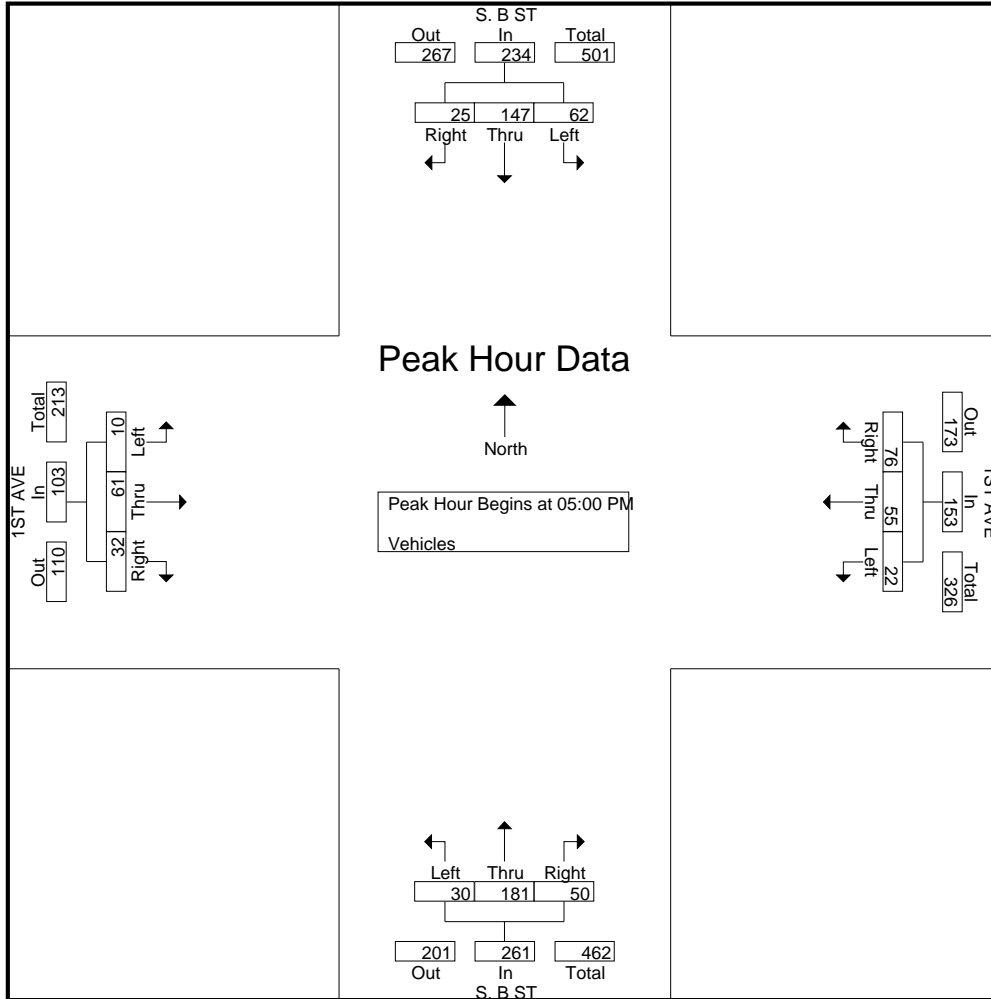

INTERSECTION CAR/PED/BIKE TRAFFIC COUNT RESULTS SUMMARY

CLIENT: FEHR & PEERS
 PROJECT: CALTRAIN TRAFFIC COUNTS
 DATE: WEDNESDAY MAY 22, 2013
 PERIOD: 4:00 PM TO 6:00 PM
 INTERSECTION: N/S RAILROAD AVENUE
 E/W 1ST AVENUE
 CITY: SAN MATEO

VEHICLE COUNTS													
15 MIN COUNTS	1	2	3	4	5	6	7	8	9	10	11	12	
PERIOD	SBRT	SBTH	SBLT	WBRT	WBTH	WBLT	NBRT	NBTH	NBLT	EBRT	EBTH	EBLT	TOTAL
400-415	2	9	2	2	20	3	2	24	8	0	0	0	72
415-430	5	9	1	5	15	2	2	25	11	13	27	0	115
430-445	2	16	0	2	21	5	4	27	5	11	30	1	124
445-500	3	10	2	4	20	7	3	31	10	23	18	0	131
500-515	1	12	2	2	19	7	3	39	6	15	25	0	131
515-530	1	19	1	1	19	5	4	22	11	18	20	1	122
530-545	2	10	3	8	26	3	5	25	14	17	30	2	145
545-600	5	13	2	7	21	1	3	23	14	14	25	1	129
HOUR TOTALS	1	2	3	4	5	6	7	8	9	10	11	12	
PERIOD	SBRT	SBTH	SBLT	WBRT	WBTH	WBLT	NBRT	NBTH	NBLT	EBRT	EBTH	EBLT	TOTAL
400-500	12	44	5	13	76	17	11	107	34	47	75	1	442
415-515	11	47	5	13	75	21	12	122	32	62	100	1	501
430-530	7	57	5	9	79	24	14	119	32	67	93	2	508
445-545	7	51	8	15	84	22	15	117	41	73	93	3	529
500-600	9	54	8	18	85	16	15	109	45	64	100	4	527

AM PEAK HOUR: 445-545

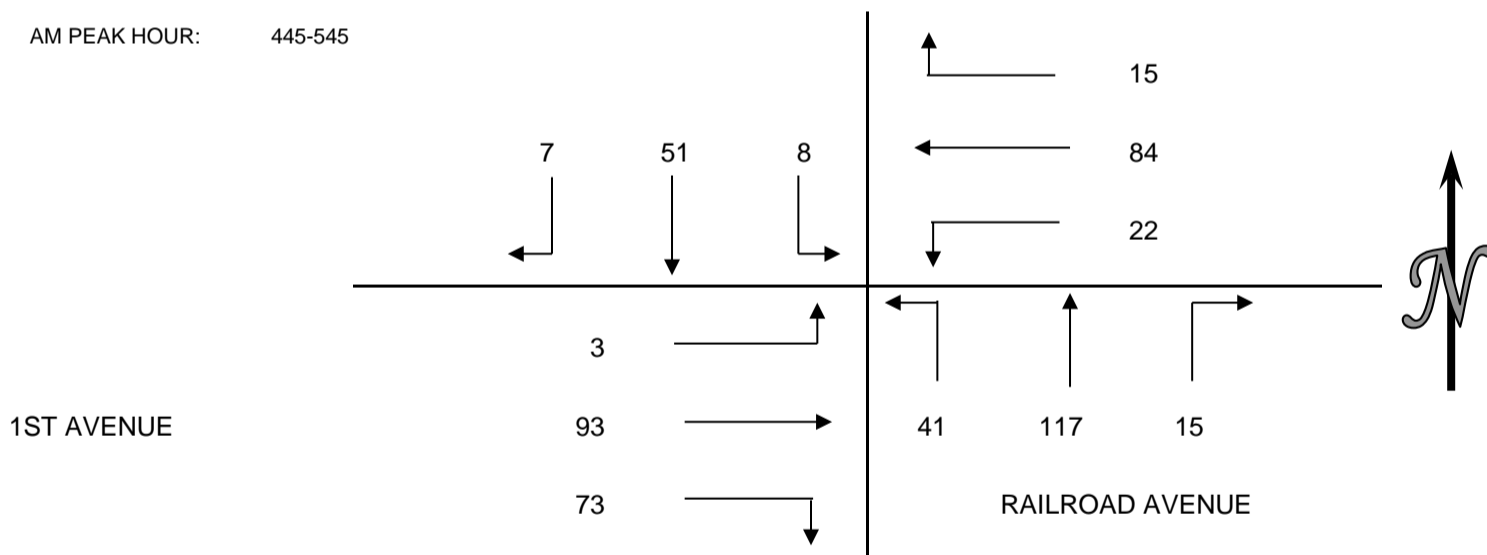

PEDESTRIAN COUNTS					
15 MIN COUNTS	NORTH LEG	EAST LEG	SOUTH LEG	WEST LEG	TOTAL
PERIOD	LEG	LEG	LEG	LEG	
400-415	2	2	3	4	11
415-430	3	1	3	2	9
430-445	5	4	2	3	14
445-500	3	5	3	2	13
500-515	9	1	5	3	18
515-530	4	5	1	1	11
530-545	12	4	3	4	23
545-600	19	8	4	8	39
HOUR TOTALS	NORTH LEG	EAST LEG	SOUTH LEG	WEST LEG	TOTAL
PERIOD	LEG	LEG	LEG	LEG	
400-500	13	12	11	11	47
415-515	20	11	13	10	54
430-530	21	15	11	9	56
445-545	28	15	12	10	65
500-600	44	18	13	16	91

BICYCLE COUNTS					
15 MIN COUNTS	NORTH LEG	EAST LEG	SOUTH LEG	WEST LEG	TOTAL
PERIOD	LEG	LEG	LEG	LEG	
400-415	0	0	1	1	2
415-430	1	2	1	0	4
430-445	1	0	0	1	2
445-500	0	0	2	2	4
500-515	0	1	0	1	2
515-530	2	2	0	0	4
530-545	0	1	6	2	9
545-600	5	2	3	1	11
HOUR TOTALS	NORTH LEG	EAST LEG	SOUTH LEG	WEST LEG	TOTAL
PERIOD	LEG	LEG	LEG	LEG	
400-500	2	2	4	4	12
415-515	2	3	3	4	12
430-530	3	3	2	4	12
445-545	2	4	8	5	19
500-600	7	6	9	4	26

Traffic Data Service

Campbell, CA
 (408) 377-2988
 tdsbay@cs.com

File Name : 40AM FINAL
 Site Code : 00000040
 Start Date : 6/4/2013
 Page No : 1

Groups Printed- Vehicles

Start Time	S. B ST Southbound					1ST AVE Westbound					S. B ST Northbound					1ST AVE Eastbound					Int. Total
	Right	Thru	Left	Peds	App. Total	Right	Thru	Left	Peds	App. Total	Right	Thru	Left	Peds	App. Total	Right	Thru	Left	Peds	App. Total	
07:00 AM	1	22	0	4	27	6	5	4	12	27	1	20	1	5	27	1	3	0	1	5	86
07:15 AM	2	10	4	10	26	11	4	2	8	25	2	20	3	0	25	1	2	0	6	9	85
07:30 AM	4	29	6	11	50	13	5	7	13	38	4	26	3	15	48	0	3	0	9	12	148
07:45 AM	2	22	7	9	40	16	13	3	13	45	1	45	7	5	58	4	4	0	7	15	158
Total	9	83	17	34	143	46	27	16	46	135	8	111	14	25	158	6	12	0	23	41	477
08:00 AM	1	33	8	14	56	11	9	1	9	30	2	21	3	9	35	6	7	2	7	22	143
08:15 AM	2	15	4	3	24	17	12	2	11	42	2	42	3	5	52	5	6	0	7	18	136
08:30 AM	2	40	4	22	68	17	9	4	23	53	8	27	6	13	54	3	3	0	22	28	203
08:45 AM	0	19	15	6	40	18	11	2	13	44	4	42	5	7	58	5	6	0	9	20	162
Total	5	107	31	45	188	63	41	9	56	169	16	132	17	34	199	19	22	2	45	88	644
Grand Total	14	190	48	79	331	109	68	25	102	304	24	243	31	59	357	25	34	2	68	129	1121
Apprch %	4.2	57.4	14.5	23.9		35.9	22.4	8.2	33.6		6.7	68.1	8.7	16.5		19.4	26.4	1.6	52.7		
Total %	1.2	16.9	4.3	7	29.5	9.7	6.1	2.2	9.1	27.1	2.1	21.7	2.8	5.3	31.8	2.2	3	0.2	6.1	11.5	

Start Time	S. B ST Southbound				1ST AVE Westbound				S. B ST Northbound				1ST AVE Eastbound				Int. Total
	Right	Thru	Left	App. Total	Right	Thru	Left	App. Total	Right	Thru	Left	App. Total	Right	Thru	Left	App. Total	
Peak Hour Analysis From 07:00 AM to 08:45 AM - Peak 1 of 1																	
Peak Hour for Entire Intersection Begins at 08:00 AM																	
08:00 AM	1	33	8	42	11	9	1	21	2	21	3	26	6	7	2	15	104
08:15 AM	2	15	4	21	17	12	2	31	2	42	3	47	5	6	0	11	110
08:30 AM	2	40	4	46	17	9	4	30	8	27	6	41	3	3	0	6	123
08:45 AM	0	19	15	34	18	11	2	31	4	42	5	51	5	6	0	11	127
Total Volume	5	107	31	143	63	41	9	113	16	132	17	165	19	22	2	43	464
% App. Total	3.5	74.8	21.7		55.8	36.3	8		9.7	80	10.3		44.2	51.2	4.7		
PHF	.625	.669	.517	.777	.875	.854	.563	.911	.500	.786	.708	.809	.792	.786	.250	.717	.913

Traffic Data Service

Campbell, CA
(408) 377-2988
tdsbay@cs.com

File Name : 40AM FINAL
Site Code : 00000040
Start Date : 6/4/2013
Page No : 2

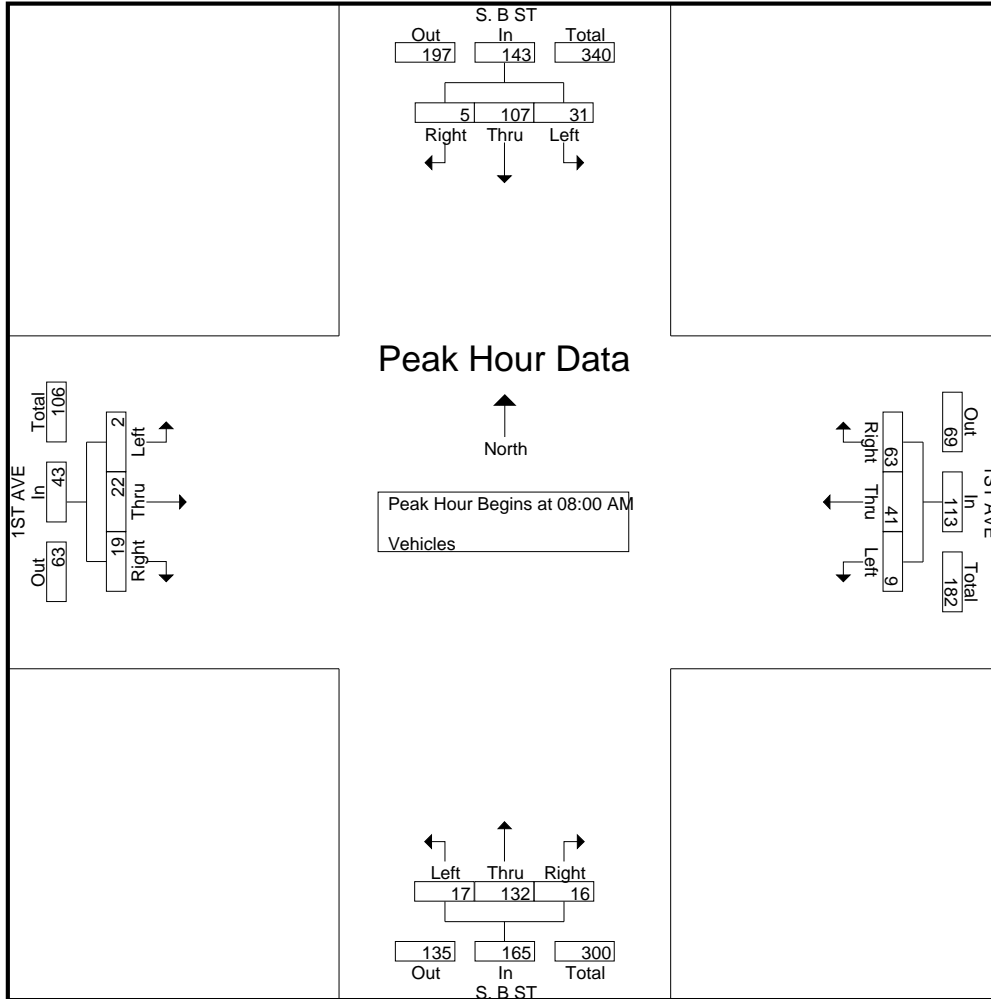

Traffic Data Service

Campbell, CA
 (408) 377-2988
 tdsbay@cs.com

File Name : 40PM FINAL
 Site Code : 00000040
 Start Date : 6/4/2013
 Page No : 1

Groups Printed- Bikes

Start Time	S. B ST Southbound					1ST AVE Westbound					S. B ST Northbound					1ST AVE Eastbound					Int. Total	
	Right	Thru	Left	Peds	App. Total	Right	Thru	Left	Peds	App. Total	Right	Thru	Left	Peds	App. Total	Right	Thru	Left	Peds	App. Total		
04:00 PM	0	0	0	0	0	0	0	0	0	0	0	1	0	0	1	0	0	0	0	0	0	1
04:15 PM	1	4	0	0	5	0	0	0	0	0	0	0	0	0	0	0	1	0	0	0	0	1
04:30 PM	0	2	0	0	2	0	0	1	0	1	0	0	0	0	0	0	0	0	0	0	0	0
04:45 PM	0	5	0	0	5	0	1	0	0	1	0	0	0	0	0	0	0	0	0	0	0	0
Total	1	11	0	0	12	0	1	1	0	2	0	1	0	0	1	0	1	0	0	1	1	16
05:00 PM	0	3	0	0	3	0	0	0	0	0	0	1	0	0	1	0	0	0	0	0	0	0
05:15 PM	0	0	0	0	0	0	0	0	0	0	0	1	0	0	1	0	0	0	0	0	0	0
05:30 PM	0	4	0	0	4	0	0	2	0	2	0	1	0	0	1	0	1	0	0	1	0	1
05:45 PM	0	5	0	0	5	0	1	0	0	1	1	0	0	0	1	0	1	0	0	1	0	1
Total	0	12	0	0	12	0	1	2	0	3	1	3	0	0	4	0	2	0	0	2	2	21
Grand Total	1	23	0	0	24	0	2	3	0	5	1	4	0	0	5	0	3	0	0	3	0	37
Apprch %	4.2	95.8	0	0		0	40	60	0		20	80	0	0		0	100	0	0		0	
Total %	2.7	62.2	0	0	64.9	0	5.4	8.1	0	13.5	2.7	10.8	0	0	13.5	0	8.1	0	0	8.1		

Start Time	S. B ST Southbound				1ST AVE Westbound				S. B ST Northbound				1ST AVE Eastbound				Int. Total
	Right	Thru	Left	App. Total	Right	Thru	Left	App. Total	Right	Thru	Left	App. Total	Right	Thru	Left	App. Total	
05:00 PM	0	3	0	3	0	0	0	0	0	1	0	1	0	0	0	0	4
05:15 PM	0	0	0	0	0	0	0	0	0	1	0	1	0	0	0	0	1
05:30 PM	0	4	0	4	0	0	2	2	0	1	0	1	0	1	0	1	8
05:45 PM	0	5	0	5	0	1	0	1	1	0	0	1	0	1	0	1	8
Total Volume	0	12	0	12	0	1	2	3	1	3	0	4	0	2	0	2	21
% App. Total	0	100	0		0	33.3	66.7		25	75	0		0	100	0		
PHF	.000	.600	.000	.600	.000	.250	.250	.375	.250	.750	.000	1.00	.000	.500	.000	.500	.656

Peak Hour Analysis From 04:00 PM to 05:45 PM - Peak 1 of 1

Peak Hour for Entire Intersection Begins at 05:00 PM

Traffic Data Service

Campbell, CA
(408) 377-2988
tdsbay@cs.com

File Name : 40PM FINAL
Site Code : 00000040
Start Date : 6/4/2013
Page No : 2

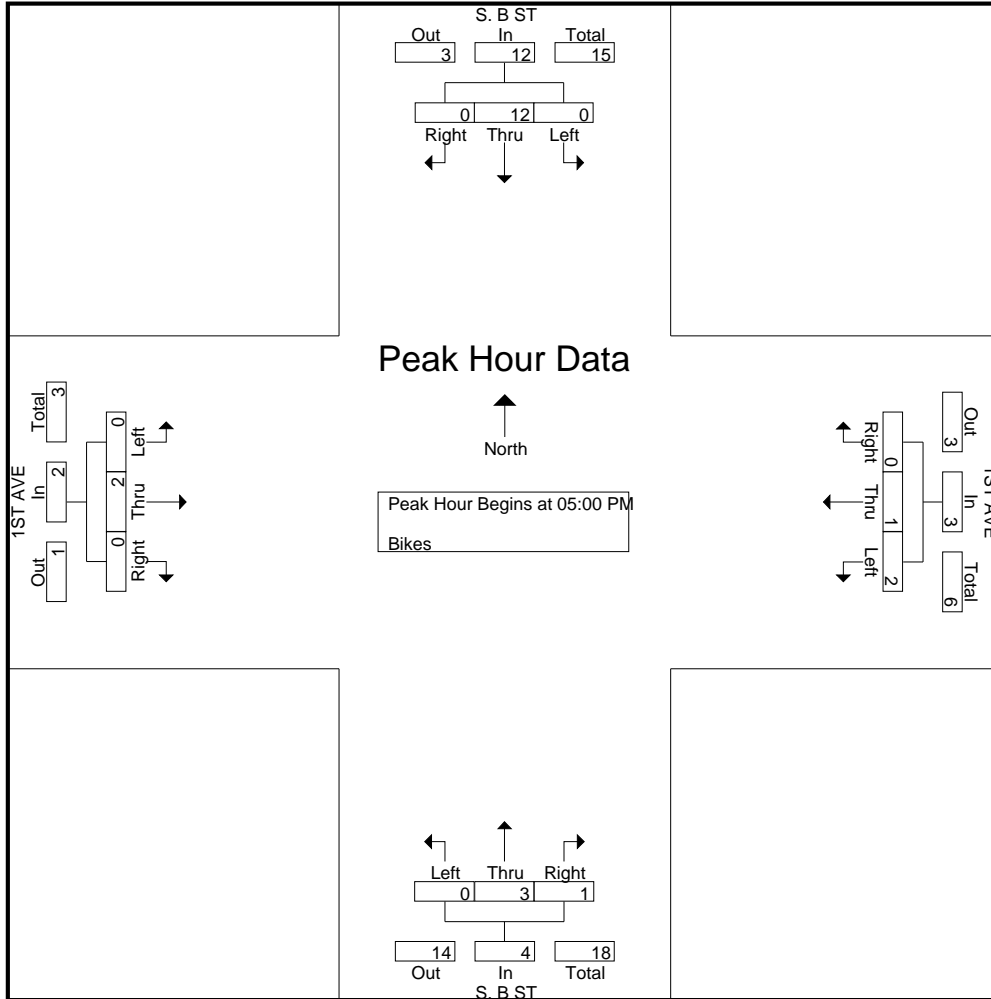

Traffic Data Service

Campbell, CA
 (408) 377-2988
 tdsbay@cs.com

File Name : 40AM FINAL
 Site Code : 00000040
 Start Date : 6/4/2013
 Page No : 1

Groups Printed- Bikes

Start Time	S. B ST Southbound					1ST AVE Westbound					S. B ST Northbound					1ST AVE Eastbound					Int. Total
	Right	Thru	Left	Peds	App. Total	Right	Thru	Left	Peds	App. Total	Right	Thru	Left	Peds	App. Total	Right	Thru	Left	Peds	App. Total	
07:00 AM	1	2	0	0	3	0	0	0	0	0	1	1	0	0	2	0	0	0	0	0	5
07:15 AM	0	2	0	0	2	0	1	0	0	1	2	0	0	0	2	0	0	0	0	0	5
07:30 AM	0	1	0	0	1	0	1	1	0	2	0	1	0	0	1	0	1	0	0	1	5
07:45 AM	0	0	0	0	0	1	0	0	0	1	1	1	1	0	3	0	0	0	0	0	4
Total	1	5	0	0	6	1	2	1	0	4	4	3	1	0	8	0	1	0	0	1	19
08:00 AM	0	0	0	0	0	0	1	1	0	2	1	2	0	0	3	0	0	0	0	0	5
08:15 AM	0	1	0	0	1	0	0	0	0	0	0	0	0	0	0	0	0	0	0	0	1
08:30 AM	0	1	0	0	1	0	0	2	0	2	0	1	0	0	1	0	0	0	0	0	4
08:45 AM	0	1	0	0	1	0	0	0	0	0	0	0	0	0	0	0	0	0	0	0	1
Total	0	3	0	0	3	0	1	3	0	4	1	3	0	0	4	0	0	0	0	0	11
Grand Total	1	8	0	0	9	1	3	4	0	8	5	6	1	0	12	0	1	0	0	1	30
Apprch %	11.1	88.9	0	0		12.5	37.5	50	0		41.7	50	8.3	0		0	100	0	0		
Total %	3.3	26.7	0	0	30	3.3	10	13.3	0	26.7	16.7	20	3.3	0	40	0	3.3	0	0	3.3	

Start Time	S. B ST Southbound				1ST AVE Westbound				S. B ST Northbound				1ST AVE Eastbound				Int. Total
	Right	Thru	Left	App. Total	Right	Thru	Left	App. Total	Right	Thru	Left	App. Total	Right	Thru	Left	App. Total	
Peak Hour Analysis From 07:00 AM to 08:45 AM - Peak 1 of 1																	
Peak Hour for Entire Intersection Begins at 07:00 AM																	
07:00 AM	1	2	0	3	0	0	0	0	1	1	0	2	0	0	0	0	5
07:15 AM	0	2	0	2	0	1	0	1	2	0	0	2	0	0	0	0	5
07:30 AM	0	1	0	1	0	1	1	2	0	1	0	1	0	1	0	1	5
07:45 AM	0	0	0	0	1	0	0	1	1	1	1	3	0	0	0	0	4
Total Volume	1	5	0	6	1	2	1	4	4	3	1	8	0	1	0	1	19
% App. Total	16.7	83.3	0		25	50	25		50	37.5	12.5		0	100	0		
PHF	.250	.625	.000	.500	.250	.500	.250	.500	.500	.750	.250	.667	.000	.250	.000	.250	.950

Traffic Data Service

Campbell, CA
 (408) 377-2988
 tdsbay@cs.com

File Name : 40AM FINAL
 Site Code : 00000040
 Start Date : 6/4/2013
 Page No : 2

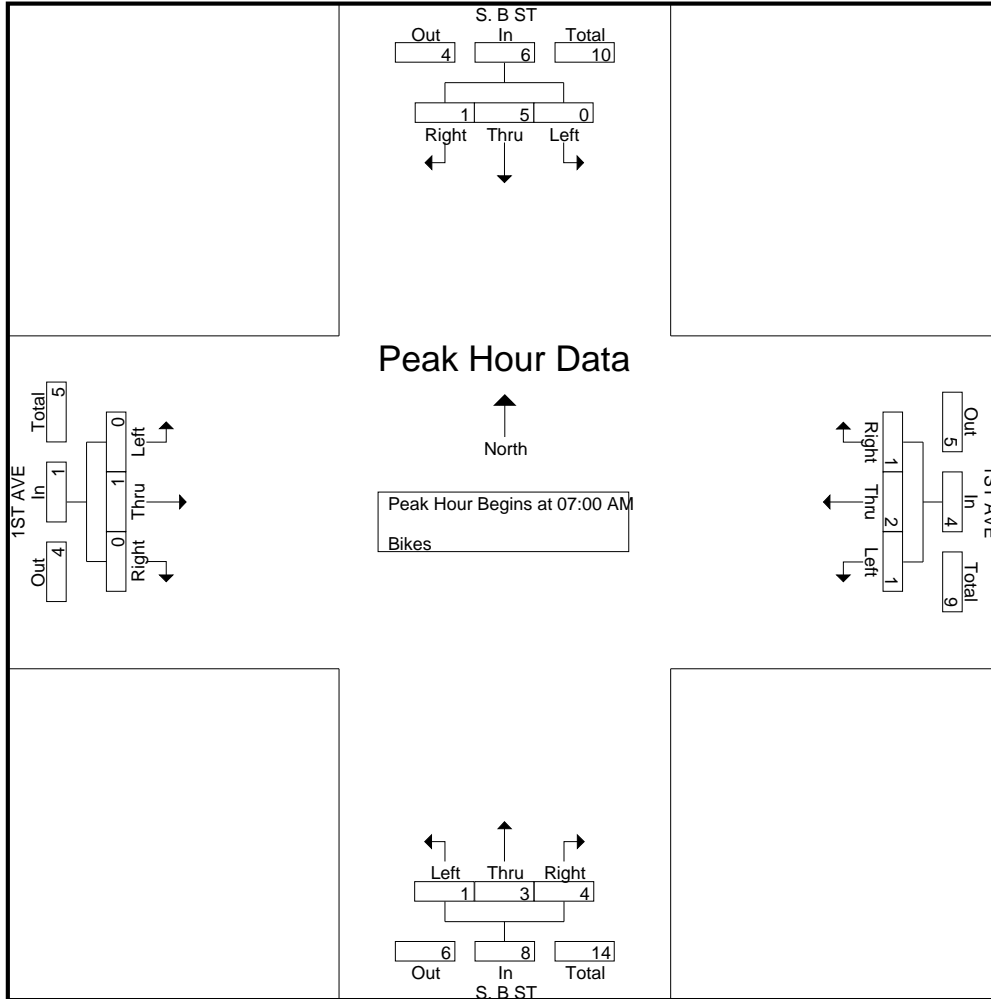

Traffic Data Service

Campbell, CA
 (408) 377-2988
 tdsbay@cs.com

File Name : 5AM FINAL
 Site Code : 00000005
 Start Date : 5/22/2013
 Page No : 1

Groups Printed- Vehicles

Start Time	S. RAILROAD AVE Southbound					9TH AVE Westbound					S. RAILROAD AVE Northbound					9TH AVE Eastbound					Int. Total
	Right	Thru	Left	Peds	App. Total	Right	Thru	Left	Peds	App. Total	Right	Thru	Left	Peds	App. Total	Right	Thru	Left	Peds	App. Total	
07:00 AM	0	0	1	4	5	0	33	5	0	38	2	0	2	6	10	3	36	0	1	40	93
07:15 AM	1	0	1	3	5	0	58	2	0	60	4	0	5	3	12	9	45	0	0	54	131
07:30 AM	1	3	1	2	7	0	130	0	0	130	3	0	6	3	12	8	55	0	0	63	212
07:45 AM	0	0	0	3	3	0	128	3	0	131	3	0	8	5	16	22	107	0	0	129	279
Total	2	3	3	12	20	0	349	10	0	359	12	0	21	17	50	42	243	0	1	286	715
08:00 AM	1	1	2	3	7	0	80	1	2	83	2	0	2	6	10	36	112	0	0	148	248
08:15 AM	1	1	0	5	7	0	104	2	2	108	4	0	8	9	21	12	92	0	0	104	240
08:30 AM	0	1	3	7	11	0	97	2	2	101	1	0	17	8	26	10	73	0	1	84	222
08:45 AM	7	1	1	5	14	0	93	1	1	95	5	0	6	5	16	10	56	0	0	66	191
Total	9	4	6	20	39	0	374	6	7	387	12	0	33	28	73	68	333	0	1	402	901
Grand Total	11	7	9	32	59	0	723	16	7	746	24	0	54	45	123	110	576	0	2	688	1616
Apprch %	18.6	11.9	15.3	54.2		0	96.9	2.1	0.9		19.5	0	43.9	36.6		16	83.7	0	0.3		
Total %	0.7	0.4	0.6	2	3.7	0	44.7	1	0.4	46.2	1.5	0	3.3	2.8	7.6	6.8	35.6	0	0.1	42.6	

Start Time	S. RAILROAD AVE Southbound				9TH AVE Westbound				S. RAILROAD AVE Northbound				9TH AVE Eastbound				Int. Total
	Right	Thru	Left	App. Total	Right	Thru	Left	App. Total	Right	Thru	Left	App. Total	Right	Thru	Left	App. Total	
Peak Hour Analysis From 07:00 AM to 08:45 AM - Peak 1 of 1																	
Peak Hour for Entire Intersection Begins at 07:30 AM																	
07:30 AM	1	3	1	5	0	130	0	130	3	0	6	9	8	55	0	63	207
07:45 AM	0	0	0	0	0	128	3	131	3	0	8	11	22	107	0	129	271
08:00 AM	1	1	2	4	0	80	1	81	2	0	2	4	36	112	0	148	237
08:15 AM	1	1	0	2	0	104	2	106	4	0	8	12	12	92	0	104	224
Total Volume	3	5	3	11	0	442	6	448	12	0	24	36	78	366	0	444	939
% App. Total	27.3	45.5	27.3		0	98.7	1.3		33.3	0	66.7		17.6	82.4	0		
PHF	.750	.417	.375	.550	.000	.850	.500	.855	.750	.000	.750	.750	.542	.817	.000	.750	.866

Traffic Data Service

Campbell, CA
 (408) 377-2988
 tdsbay@cs.com

File Name : 5AM FINAL
 Site Code : 00000005
 Start Date : 5/22/2013
 Page No : 2

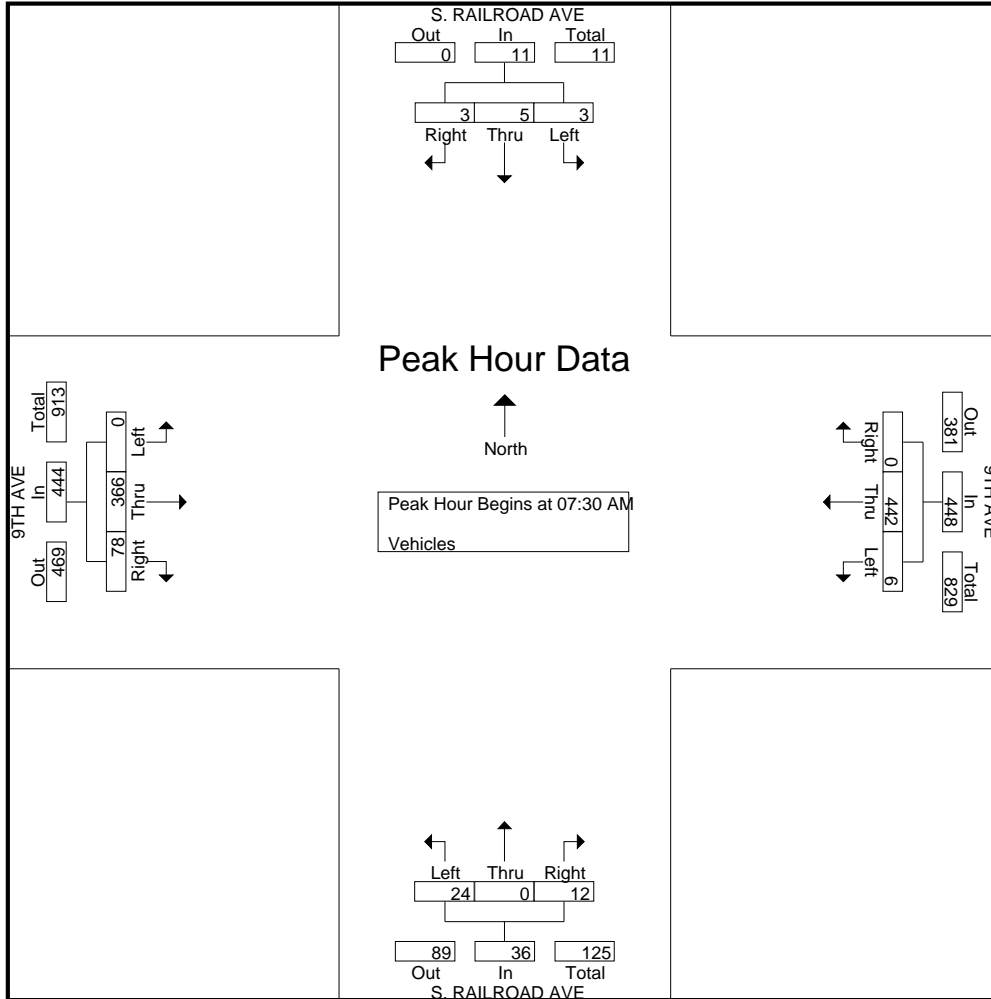

Traffic Data Service

Campbell, CA
 (408) 377-2988
 tdsbay@cs.com

File Name : 5AM FINAL
 Site Code : 00000005
 Start Date : 5/22/2013
 Page No : 1

Groups Printed- Bikes

Start Time	S. RAILROAD AVE Southbound					9TH AVE Westbound					S. RAILROAD AVE Northbound					9TH AVE Eastbound					Int. Total	
	Right	Thru	Left	Peds	App. Total	Right	Thru	Left	Peds	App. Total	Right	Thru	Left	Peds	App. Total	Right	Thru	Left	Peds	App. Total		
07:00 AM	1	0	0	0	1	0	1	0	0	1	0	0	0	0	0	0	0	0	0	0	0	2
07:15 AM	0	0	0	0	0	0	0	0	0	0	0	0	0	0	0	0	0	0	0	0	0	0
07:30 AM	0	0	0	0	0	0	0	0	0	0	0	0	0	0	0	0	0	0	0	0	0	0
07:45 AM	0	1	0	0	1	0	2	0	0	2	0	0	0	0	0	3	1	0	0	0	4	7
Total	1	1	0	0	2	0	3	0	0	3	0	0	0	0	0	3	1	0	0	0	4	9
08:00 AM	0	0	0	0	0	0	2	0	0	2	0	0	0	0	0	1	0	0	0	0	1	3
08:15 AM	0	0	0	0	0	0	0	0	0	0	0	0	0	0	0	0	0	0	0	0	0	0
08:30 AM	0	0	0	0	0	0	3	0	0	3	0	0	0	0	0	0	0	0	0	0	0	3
08:45 AM	0	0	0	0	0	0	0	0	0	0	0	0	1	0	1	0	0	0	0	0	0	1
Total	0	0	0	0	0	0	5	0	0	5	0	0	1	0	1	1	0	0	0	0	1	7
Grand Total	1	1	0	0	2	0	8	0	0	8	0	0	1	0	1	4	1	0	0	0	5	16
Apprch %	50	50	0	0		0	100	0	0		0	0	100	0		80	20	0	0			
Total %	6.2	6.2	0	0	12.5	0	50	0	0	50	0	0	6.2	0	6.2	25	6.2	0	0		31.2	

Start Time	S. RAILROAD AVE Southbound					9TH AVE Westbound					S. RAILROAD AVE Northbound					9TH AVE Eastbound					Int. Total	
	Right	Thru	Left	Peds	App. Total	Right	Thru	Left	Peds	App. Total	Right	Thru	Left	Peds	App. Total	Right	Thru	Left	Peds	App. Total		
07:45 AM	0	1	0	0	1	0	2	0	0	2	0	0	0	0	0	3	1	0	0	0	4	7
08:00 AM	0	0	0	0	0	0	2	0	0	2	0	0	0	0	0	1	0	0	0	0	1	3
08:15 AM	0	0	0	0	0	0	0	0	0	0	0	0	0	0	0	0	0	0	0	0	0	0
08:30 AM	0	0	0	0	0	0	3	0	0	3	0	0	0	0	0	0	0	0	0	0	0	3
Total Volume	0	1	0	0	1	0	7	0	0	7	0	0	0	0	0	4	1	0	0	0	5	13
% App. Total	0	100	0	0		0	100	0	0		0	0	0	0		80	20	0	0			
PHF	.000	.250	.000	.000	.250	.000	.583	.000	.000	.583	.000	.000	.000	.000	.000	.333	.250	.000	.000	.000	.313	.464

Peak Hour Analysis From 07:00 AM to 08:45 AM - Peak 1 of 1

Peak Hour for Entire Intersection Begins at 07:45 AM

Traffic Data Service

Campbell, CA

(408) 377-2988

tdsbay@cs.com

File Name : 5AM FINAL

Site Code : 00000005

Start Date : 5/22/2013

Page No : 2

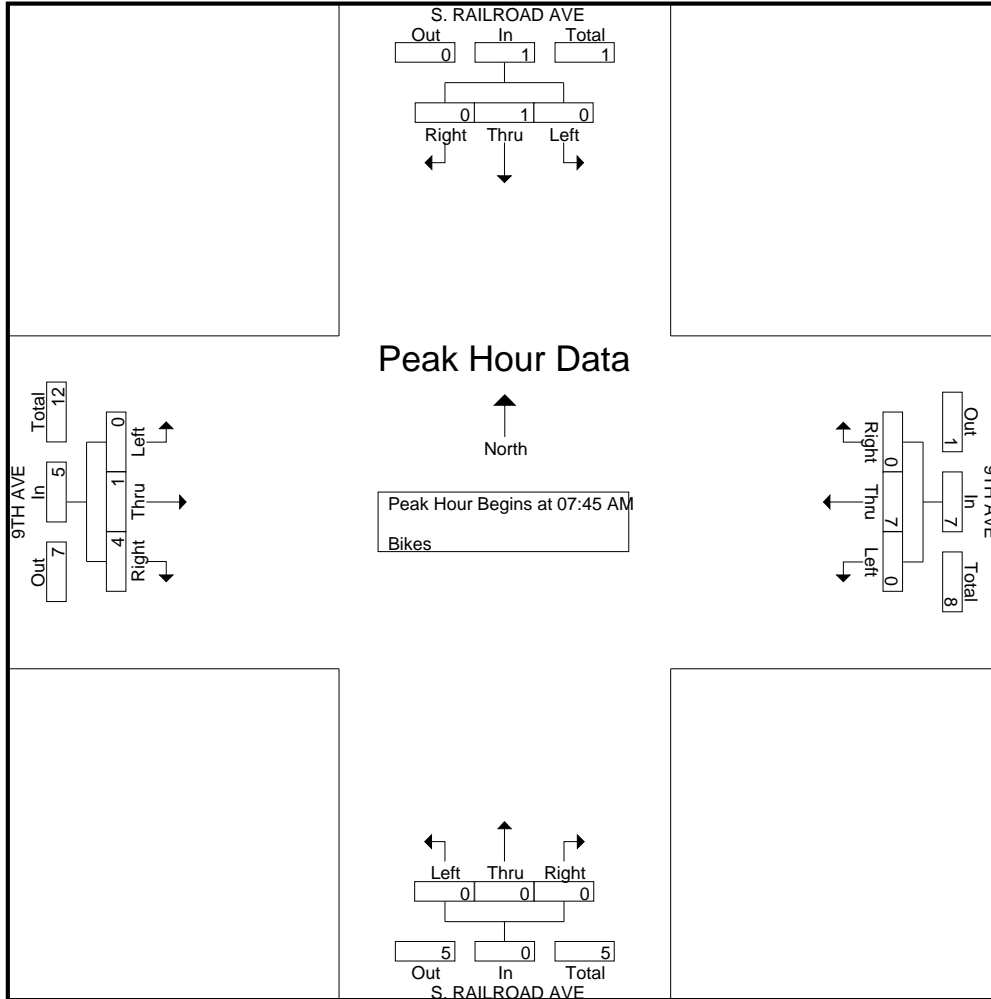

Traffic Data Service

Campbell, CA
 (408) 377-2988
 tdsbay@cs.com

File Name : 5PM FINAL
 Site Code : 00000005
 Start Date : 5/22/2013
 Page No : 1

Groups Printed- Vehicles

Start Time	S. RAILROAD AVE Southbound					9TH AVE Westbound					S. RAILROAD AVE Northbound					9TH AVE Eastbound					Int. Total
	Right	Thru	Left	Peds	App. Total	Right	Thru	Left	Peds	App. Total	Right	Thru	Left	Peds	App. Total	Right	Thru	Left	Peds	App. Total	
04:00 PM	4	1	2	5	12	0	91	0	2	93	3	0	9	8	20	12	97	0	0	109	234
04:15 PM	8	1	3	0	12	0	61	1	0	62	2	0	7	3	12	14	83	0	0	97	183
04:30 PM	5	2	4	8	19	0	88	2	0	90	0	0	8	1	9	10	104	0	0	114	232
04:45 PM	6	1	0	6	13	0	98	3	0	101	1	0	9	5	15	16	88	0	0	104	233
Total	23	5	9	19	56	0	338	6	2	346	6	0	33	17	56	52	372	0	0	424	882
05:00 PM	4	1	3	3	11	0	97	1	0	98	9	0	6	5	20	10	105	0	0	115	244
05:15 PM	3	0	2	13	18	0	79	2	0	81	3	0	9	2	14	13	124	0	0	137	250
05:30 PM	4	1	1	2	8	0	101	2	1	104	8	0	10	9	27	13	101	0	1	115	254
05:45 PM	4	0	4	6	14	0	86	2	0	88	3	0	11	2	16	11	93	0	0	104	222
Total	15	2	10	24	51	0	363	7	1	371	23	0	36	18	77	47	423	0	1	471	970
Grand Total	38	7	19	43	107	0	701	13	3	717	29	0	69	35	133	99	795	0	1	895	1852
Apprch %	35.5	6.5	17.8	40.2		0	97.8	1.8	0.4		21.8	0	51.9	26.3		11.1	88.8	0	0.1		
Total %	2.1	0.4	1	2.3	5.8	0	37.9	0.7	0.2	38.7	1.6	0	3.7	1.9	7.2	5.3	42.9	0	0.1	48.3	

Start Time	S. RAILROAD AVE Southbound				9TH AVE Westbound				S. RAILROAD AVE Northbound				9TH AVE Eastbound				Int. Total
	Right	Thru	Left	App. Total	Right	Thru	Left	App. Total	Right	Thru	Left	App. Total	Right	Thru	Left	App. Total	
Peak Hour Analysis From 04:00 PM to 05:45 PM - Peak 1 of 1																	
Peak Hour for Entire Intersection Begins at 04:45 PM																	
04:45 PM	6	1	0	7	0	98	3	101	1	0	9	10	16	88	0	104	222
05:00 PM	4	1	3	8	0	97	1	98	9	0	6	15	10	105	0	115	236
05:15 PM	3	0	2	5	0	79	2	81	3	0	9	12	13	124	0	137	235
05:30 PM	4	1	1	6	0	101	2	103	8	0	10	18	13	101	0	114	241
Total Volume	17	3	6	26	0	375	8	383	21	0	34	55	52	418	0	470	934
% App. Total	65.4	11.5	23.1		0	97.9	2.1		38.2	0	61.8		11.1	88.9	0		
PHF	.708	.750	.500	.813	.000	.928	.667	.930	.583	.000	.850	.764	.813	.843	.000	.858	.969

Traffic Data Service

Campbell, CA
 (408) 377-2988
 tdsbay@cs.com

File Name : 5PM FINAL
 Site Code : 00000005
 Start Date : 5/22/2013
 Page No : 2

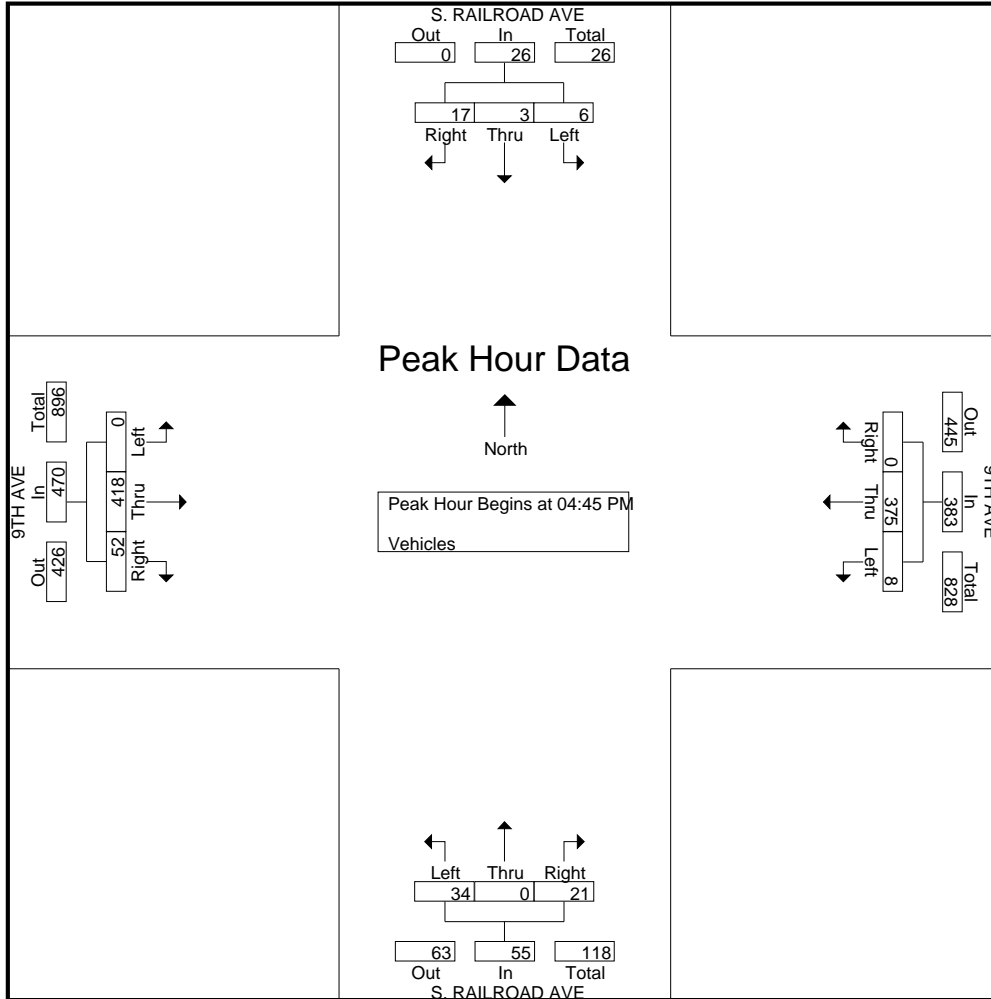

Traffic Data Service

Campbell, CA
 (408) 377-2988
 tdsbay@cs.com

File Name : 5PM FINAL
 Site Code : 00000005
 Start Date : 5/22/2013
 Page No : 1

Groups Printed- Bikes

Start Time	S. RAILROAD AVE Southbound					9TH AVE Westbound					S. RAILROAD AVE Northbound					9TH AVE Eastbound					Int. Total
	Right	Thru	Left	Peds	App. Total	Right	Thru	Left	Peds	App. Total	Right	Thru	Left	Peds	App. Total	Right	Thru	Left	Peds	App. Total	
04:00 PM	0	0	0	0	0	0	0	0	0	0	0	0	0	0	0	0	1	0	0	1	1
04:15 PM	0	0	0	0	0	0	0	0	0	0	1	0	0	0	1	0	2	0	0	2	3
04:30 PM	0	0	0	0	0	0	2	0	0	2	0	0	0	0	0	0	0	0	0	0	2
04:45 PM	0	0	0	0	0	0	1	0	0	1	0	0	0	0	0	0	1	0	0	1	2
Total	0	0	0	0	0	0	3	0	0	3	1	0	0	0	1	0	4	0	0	4	8
05:00 PM	0	0	0	0	0	0	0	0	0	0	0	0	0	0	0	0	1	0	0	1	1
05:15 PM	0	0	0	0	0	0	0	0	0	0	0	0	0	0	0	0	0	0	0	0	0
05:30 PM	0	0	0	0	0	0	0	0	0	0	0	0	0	0	0	0	0	0	0	0	0
05:45 PM	0	0	1	0	1	0	1	0	0	1	0	0	0	0	0	1	0	0	0	1	3
Total	0	0	1	0	1	0	1	0	0	1	0	0	0	0	0	1	1	0	0	2	4
Grand Total	0	0	1	0	1	0	4	0	0	4	1	0	0	0	1	1	5	0	0	6	12
Apprch %	0	0	100	0		0	100	0	0		100	0	0	0		16.7	83.3	0	0		
Total %	0	0	8.3	0	8.3	0	33.3	0	0	33.3	8.3	0	0	0	8.3	8.3	41.7	0	0	50	

Start Time	S. RAILROAD AVE Southbound					9TH AVE Westbound					S. RAILROAD AVE Northbound					9TH AVE Eastbound					Int. Total
	Right	Thru	Left	Peds	App. Total	Right	Thru	Left	Peds	App. Total	Right	Thru	Left	Peds	App. Total	Right	Thru	Left	Peds	App. Total	
04:00 PM	0	0	0	0	0	0	0	0	0	0	0	0	0	0	0	0	1	0	0	1	1
04:15 PM	0	0	0	0	0	0	0	0	0	0	1	0	0	0	1	0	2	0	0	2	3
04:30 PM	0	0	0	0	0	0	2	0	0	2	0	0	0	0	0	0	0	0	0	0	2
04:45 PM	0	0	0	0	0	0	1	0	0	1	0	0	0	0	0	0	1	0	0	1	2
Total Volume	0	0	0	0	0	0	3	0	0	3	1	0	0	0	1	0	4	0	0	4	8
% App. Total	0	0	0	0		0	100	0	0		100	0	0	0		0	100	0	0		
PHF	.000	.000	.000	.000	.000	.000	.375	.000	.000	.375	.250	.000	.000	.000	.250	.000	.500	.000	.000	.500	.667

Peak Hour Analysis From 04:00 PM to 05:45 PM - Peak 1 of 1

Peak Hour for Entire Intersection Begins at 04:00 PM

Traffic Data Service

Campbell, CA

(408) 377-2988

tdsbay@cs.com

File Name : 5PM FINAL

Site Code : 00000005

Start Date : 5/22/2013

Page No : 2

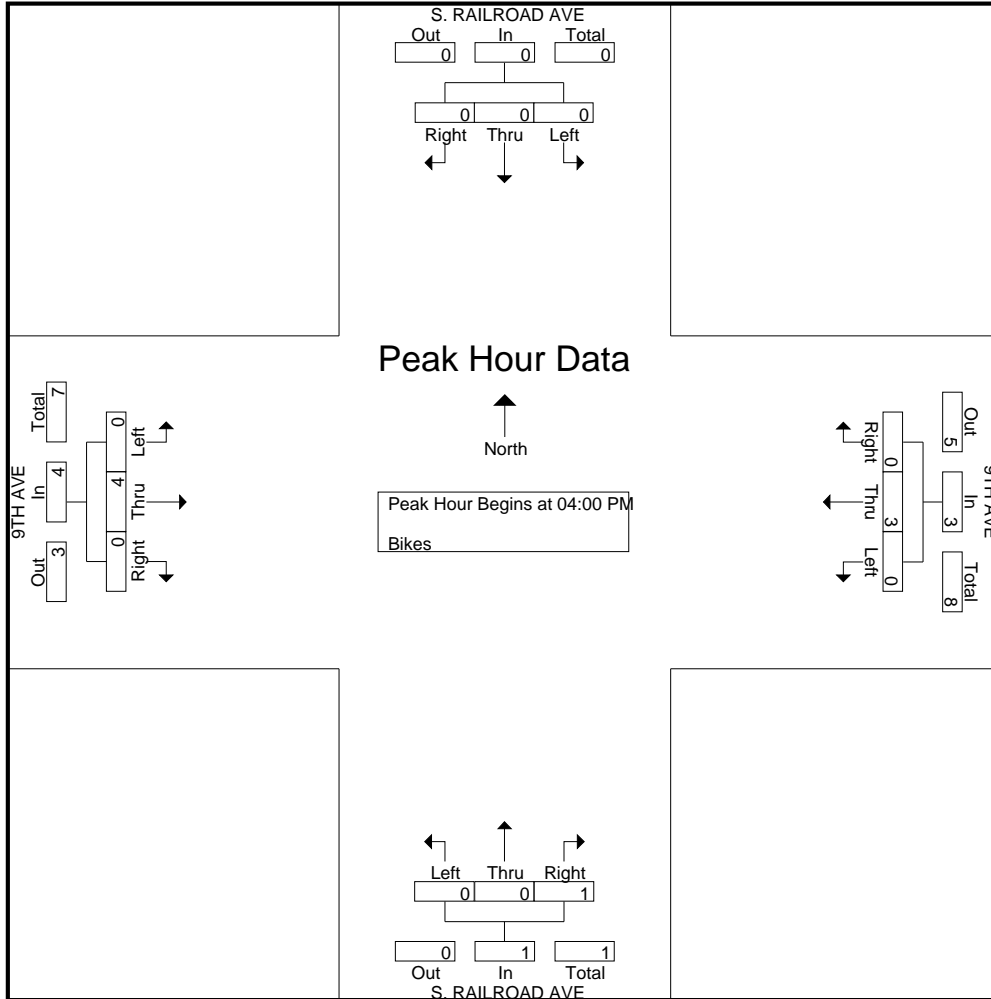

All Traffic Data

(916) 771-8700

City of San Mateo

File Name : 12-7153-013 South B-9th

Site Code : 00000000

Start Date : 4/18/2012

Page No : 1

Groups Printed- Unshifted

Start Time	South B Street Southbound				9th Avenue Westbound				South B Street Northbound				9th Avenue Eastbound				Int. Total
	Left	Thru	Right	App. Total	Left	Thru	Right	App. Total	Left	Thru	Right	App. Total	Left	Thru	Right	App. Total	
07:00	7	8	4	19	10	28	8	46	0	4	16	20	1	15	0	16	101
07:15	13	8	4	25	11	42	7	60	0	12	14	26	2	29	2	33	144
07:30	12	7	8	27	20	94	13	127	2	28	20	50	2	43	2	47	251
07:45	21	13	8	42	22	76	23	121	2	31	55	88	10	73	1	84	335
Total	53	36	24	113	63	240	51	354	4	75	105	184	15	160	5	180	831
08:00	18	19	14	51	32	50	20	102	1	28	49	78	11	55	0	66	297
08:15	22	10	9	41	20	50	20	90	4	19	30	53	8	42	1	51	235
08:30	26	13	8	47	26	54	18	98	2	15	31	48	10	42	4	56	249
08:45	14	11	11	36	17	49	19	85	0	13	18	31	6	44	2	52	204
Total	80	53	42	175	95	203	77	375	7	75	128	210	35	183	7	225	985
16:00	20	23	16	59	27	43	18	88	1	12	39	52	16	36	1	53	252
16:15	13	18	14	45	28	53	17	98	2	17	33	52	5	46	4	55	250
16:30	29	18	11	58	16	49	22	87	3	19	44	66	11	42	4	57	268
16:45	25	19	12	56	21	52	18	91	2	21	28	51	8	48	4	60	258
Total	87	78	53	218	92	197	75	364	8	69	144	221	40	172	13	225	1028
17:00	20	24	10	54	22	61	31	114	0	21	39	60	14	40	1	55	283
17:15	29	21	15	65	23	59	21	103	2	24	36	62	10	55	2	67	297
17:30	13	15	21	49	21	55	35	111	2	28	35	65	10	53	3	66	291
17:45	25	16	7	48	28	47	15	90	0	17	31	48	4	41	4	49	235
Total	87	76	53	216	94	222	102	418	4	90	141	235	38	189	10	237	1106
Grand Total	307	243	172	722	344	862	305	1511	23	309	518	850	128	704	35	867	3950
Apprch %	42.5	33.7	23.8		22.8	57	20.2		2.7	36.4	60.9		14.8	81.2	4		
Total %	7.8	6.2	4.4	18.3	8.7	21.8	7.7	38.3	0.6	7.8	13.1	21.5	3.2	17.8	0.9	21.9	

Start Time	South B Street Southbound				9th Avenue Westbound				South B Street Northbound				9th Avenue Eastbound				Int. Total
	Left	Thru	Right	App. Total	Left	Thru	Right	App. Total	Left	Thru	Right	App. Total	Left	Thru	Right	App. Total	
Peak Hour Analysis From 07:00 to 08:45 - Peak 1 of 1																	
Peak Hour for Entire Intersection Begins at 07:30																	
07:30	12	7	8	27	20	94	13	127	2	28	20	50	2	43	2	47	251
07:45	21	13	8	42	22	76	23	121	2	31	55	88	10	73	1	84	335
08:00	18	19	14	51	32	50	20	102	1	28	49	78	11	55	0	66	297
08:15	22	10	9	41	20	50	20	90	4	19	30	53	8	42	1	51	235
Total Volume	73	49	39	161	94	270	76	440	9	106	154	269	31	213	4	248	1118
% App. Total	45.3	30.4	24.2		21.4	61.4	17.3		3.3	39.4	57.2		12.5	85.9	1.6		

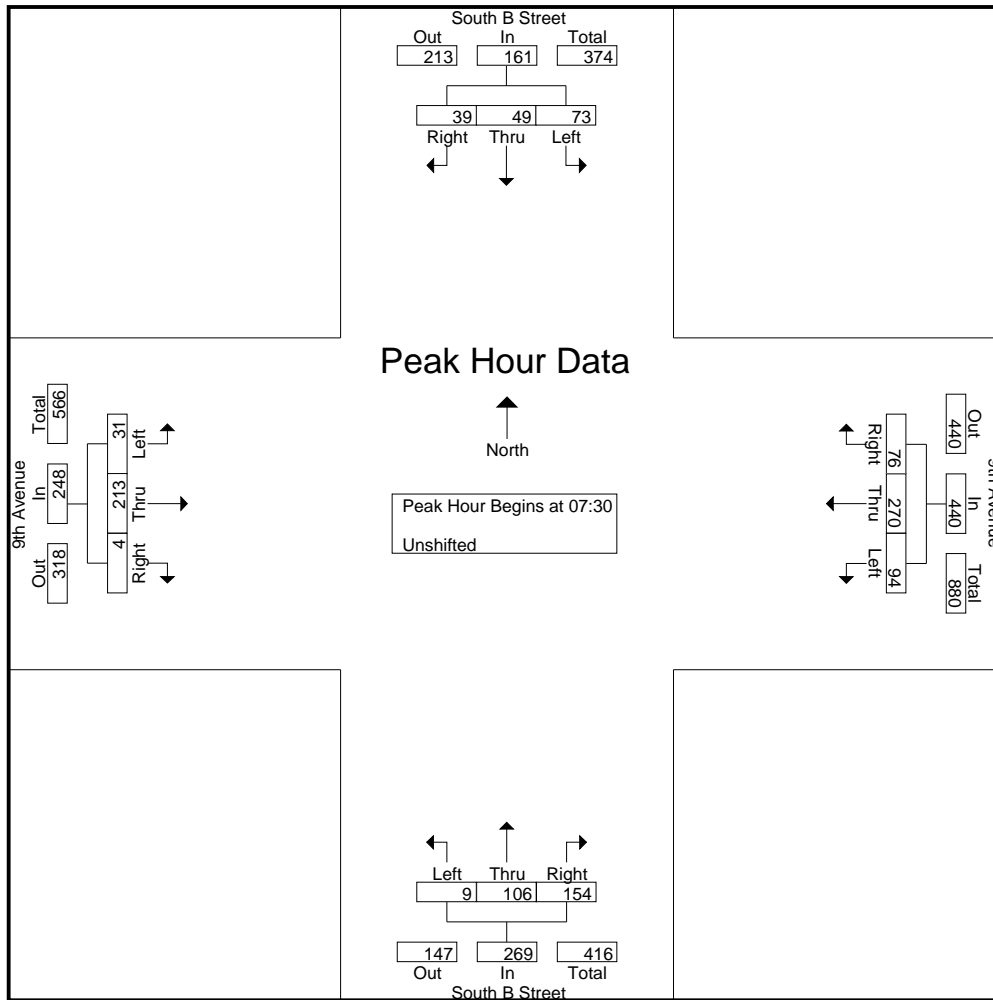

Peak Hour Analysis From 16:00 to 17:45 - Peak 1 of 1
Peak Hour for Entire Intersection Begins at 16:45

16:45	25	19	12	56	21	52	18	91	2	21	28	51	8	48	4	60	258
17:00	20	24	10	54	22	61	31	114	0	21	39	60	14	40	1	55	283
17:15	29	21	15	65	23	59	21	103	2	24	36	62	10	55	2	67	297
17:30	13	15	21	49	21	55	35	111	2	28	35	65	10	53	3	66	291
Total Volume	87	79	58	224	87	227	105	419	6	94	138	238	42	196	10	248	1129
% App. Total	38.8	35.3	25.9		20.8	54.2	25.1		2.5	39.5	58		16.9	79	4		
PHF	.750	.823	.690	.862	.946	.930	.750	.919	.750	.839	.885	.915	.750	.891	.625	.925	.950

All Traffic Data

(916) 771-8700

City of San Mateo

File Name : 12-7153-013 South B-9th

Site Code : 00000000

Start Date : 4/18/2012

Page No : 3

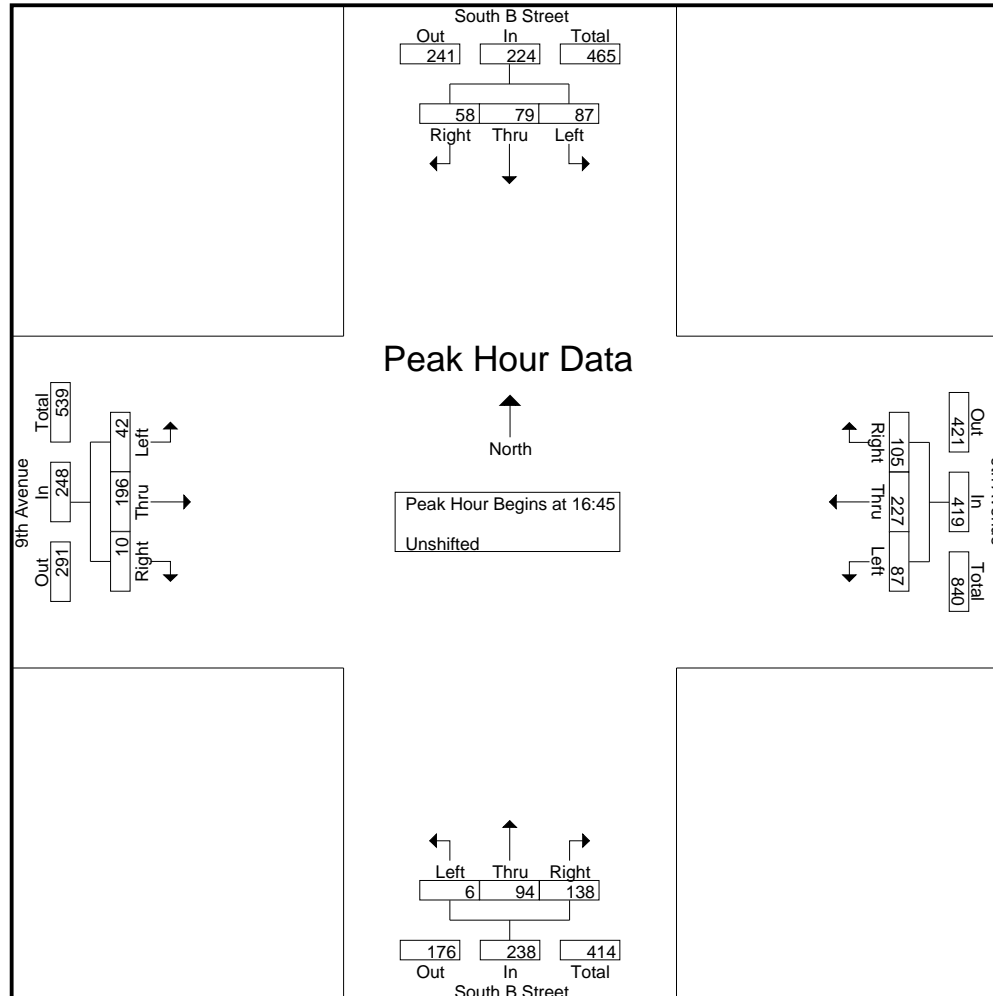

Traffic Data Service

Campbell, CA
 (408) 377-2988
 tdsbay@cs.com

File Name : 2AM FINAL
 Site Code : 00000002
 Start Date : 5/23/2013
 Page No : 1

Groups Printed- Bikes

Start Time	TRANSIT CENTER WAY Southbound					1ST AVE Westbound					PARKING GARAGE EXIT Northbound					1ST AVE Eastbound					Int. Total
	Right	Thru	Left	Peds	App. Total	Right	Thru	Left	Peds	App. Total	Right	Thru	Left	Peds	App. Total	Right	Thru	Left	Peds	App. Total	
07:00 AM	0	0	0	0	0	0	1	0	0	1	0	0	0	0	0	0	0	0	0	0	1
07:15 AM	0	0	0	0	0	0	0	0	0	0	0	0	0	0	0	0	2	0	0	0	2
07:30 AM	0	0	0	0	0	0	2	0	0	2	0	0	0	0	0	0	4	1	0	0	5
07:45 AM	0	0	0	0	0	0	1	0	0	1	0	0	0	0	0	0	1	0	0	0	2
Total	0	0	0	0	0	0	4	0	0	4	0	0	0	0	0	0	7	1	0	0	12
08:00 AM	0	0	0	0	0	0	2	0	0	2	0	0	0	0	0	0	0	0	0	0	2
08:15 AM	0	0	0	0	0	0	0	0	0	0	0	0	0	0	0	0	0	0	0	0	0
08:30 AM	0	0	0	0	0	1	4	0	0	5	0	0	0	0	0	0	0	0	0	0	5
08:45 AM	0	0	0	0	0	0	0	0	0	0	0	0	0	0	0	0	0	0	0	0	0
Total	0	0	0	0	0	1	6	0	0	7	0	0	0	0	0	0	0	0	0	0	7
Grand Total	0	0	0	0	0	1	10	0	0	11	0	0	0	0	0	0	7	1	0	0	19
Apprch %	0	0	0	0		9.1	90.9	0	0		0	0	0	0		0	87.5	12.5	0		
Total %	0	0	0	0		5.3	52.6	0	0	57.9	0	0	0	0		0	36.8	5.3	0	42.1	

Start Time	TRANSIT CENTER WAY Southbound				1ST AVE Westbound				PARKING GARAGE EXIT Northbound				1ST AVE Eastbound				Int. Total
	Right	Thru	Left	App. Total	Right	Thru	Left	App. Total	Right	Thru	Left	App. Total	Right	Thru	Left	App. Total	
07:15 AM	0	0	0	0	0	0	0	0	0	0	0	0	0	2	0	2	2
07:30 AM	0	0	0	0	0	2	0	2	0	0	0	0	0	4	1	5	7
07:45 AM	0	0	0	0	0	1	0	1	0	0	0	0	0	1	0	1	2
08:00 AM	0	0	0	0	0	2	0	2	0	0	0	0	0	0	0	0	2
Total Volume	0	0	0	0	0	5	0	5	0	0	0	0	0	7	1	8	13
% App. Total	0	0	0		0	100	0		0	0	0		0	87.5	12.5		
PHF	.000	.000	.000	.000	.000	.625	.000	.625	.000	.000	.000	.000	.000	.438	.250	.400	.464

Peak Hour Analysis From 07:00 AM to 08:45 AM - Peak 1 of 1

Peak Hour for Entire Intersection Begins at 07:15 AM

Traffic Data Service

Campbell, CA

(408) 377-2988

tdsbay@cs.com

File Name : 2AM FINAL

Site Code : 00000002

Start Date : 5/23/2013

Page No : 2

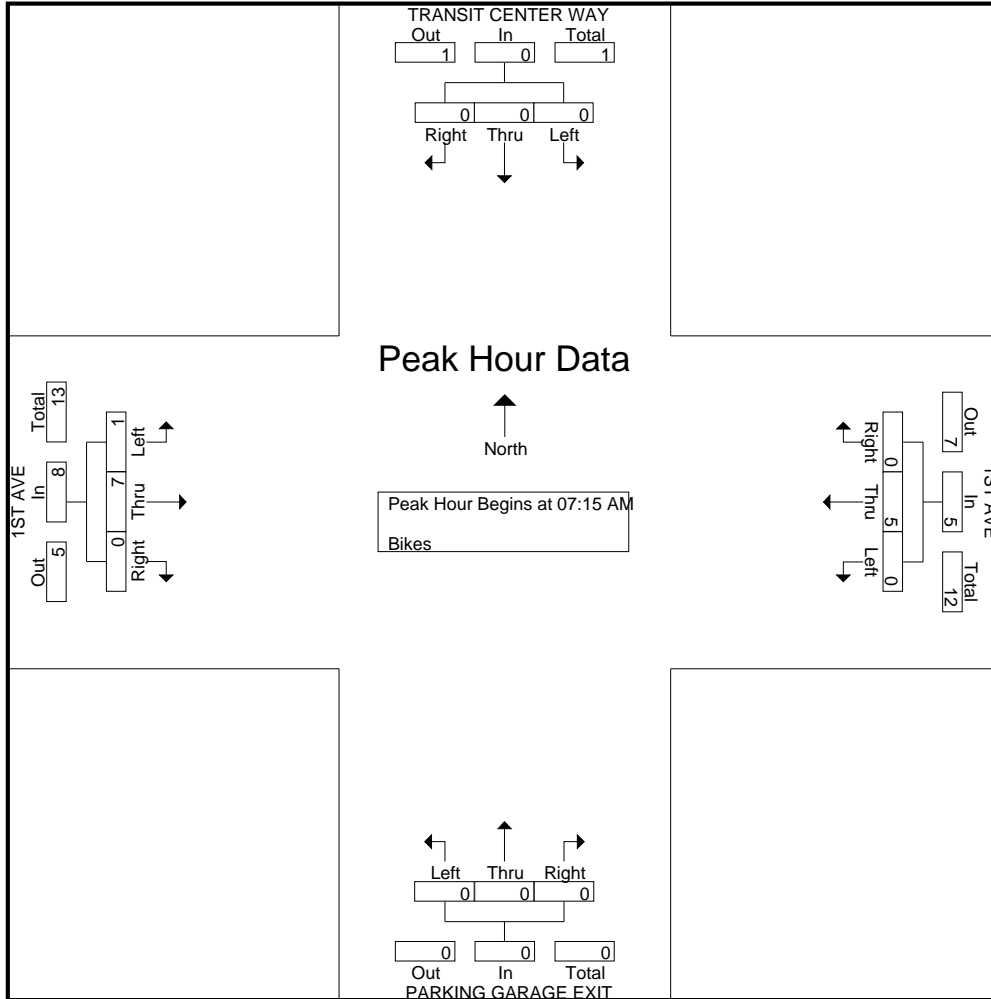

Traffic Data Service

Campbell, CA
 (408) 377-2988
 tdsbay@cs.com

File Name : 2PM FINAL
 Site Code : 00000002
 Start Date : 5/23/2013
 Page No : 1

Groups Printed- Vehicles

Start Time	TRANSIT CENTER WAY Southbound					1ST AVE Westbound					PARKING GARAGE EXIT Northbound					1ST AVE Eastbound					Int. Total
	Right	Thru	Left	Peds	App. Total	Right	Thru	Left	Peds	App. Total	Right	Thru	Left	Peds	App. Total	Right	Thru	Left	Peds	App. Total	
04:00 PM	0	0	0	24	24	3	26	0	4	33	13	1	12	9	35	0	27	10	7	44	136
04:15 PM	0	0	0	21	21	7	21	0	6	34	8	0	6	15	29	0	39	5	7	51	135
04:30 PM	0	0	0	32	32	4	18	0	5	27	5	0	8	12	25	1	37	2	7	47	131
04:45 PM	0	0	0	27	27	10	40	0	3	53	10	1	9	8	28	0	42	12	13	67	175
Total	0	0	0	104	104	24	105	0	18	147	36	2	35	44	117	1	145	29	34	209	577
05:00 PM	0	0	0	12	12	6	22	0	5	33	10	4	13	17	44	0	48	8	12	68	157
05:15 PM	0	0	0	22	22	6	24	0	5	35	9	1	6	17	33	0	37	6	12	55	145
05:30 PM	0	0	0	69	69	10	29	0	8	47	4	2	6	19	31	0	34	5	28	67	214
05:45 PM	0	0	0	38	38	6	23	0	0	29	17	1	5	11	34	0	51	10	19	80	181
Total	0	0	0	141	141	28	98	0	18	144	40	8	30	64	142	0	170	29	71	270	697
Grand Total	0	0	0	245	245	52	203	0	36	291	76	10	65	108	259	1	315	58	105	479	1274
Apprch %	0	0	0	100		17.9	69.8	0	12.4		29.3	3.9	25.1	41.7		0.2	65.8	12.1	21.9		
Total %	0	0	0	19.2	19.2	4.1	15.9	0	2.8	22.8	6	0.8	5.1	8.5	20.3	0.1	24.7	4.6	8.2	37.6	

Start Time	TRANSIT CENTER WAY Southbound				1ST AVE Westbound				PARKING GARAGE EXIT Northbound				1ST AVE Eastbound				Int. Total
	Right	Thru	Left	App. Total	Right	Thru	Left	App. Total	Right	Thru	Left	App. Total	Right	Thru	Left	App. Total	
04:45 PM	0	0	0	0	10	40	0	50	10	1	9	20	0	42	12	54	124
05:00 PM	0	0	0	0	6	22	0	28	10	4	13	27	0	48	8	56	111
05:15 PM	0	0	0	0	6	24	0	30	9	1	6	16	0	37	6	43	89
05:30 PM	0	0	0	0	10	29	0	39	4	2	6	12	0	34	5	39	90
Total Volume	0	0	0	0	32	115	0	147	33	8	34	75	0	161	31	192	414
% App. Total	0	0	0		21.8	78.2	0		44	10.7	45.3		0	83.9	16.1		
PHF	.000	.000	.000	.000	.800	.719	.000	.735	.825	.500	.654	.694	.000	.839	.646	.857	.835

Peak Hour Analysis From 04:00 PM to 05:45 PM - Peak 1 of 1

Peak Hour for Entire Intersection Begins at 04:45 PM

Traffic Data Service

Campbell, CA

(408) 377-2988

tdsbay@cs.com

File Name : 2PM FINAL

Site Code : 00000002

Start Date : 5/23/2013

Page No : 2

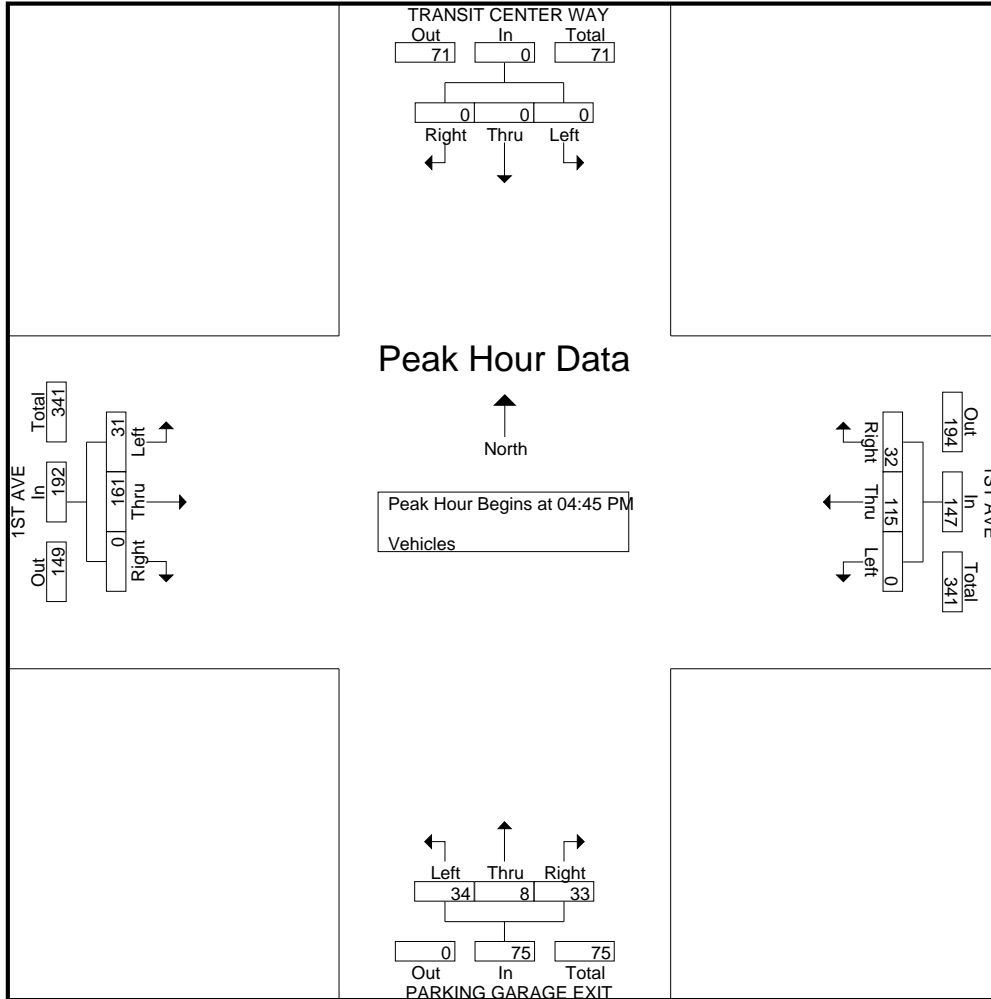

Traffic Data Service

Campbell, CA
 (408) 377-2988
 tdsbay@cs.com

File Name : 2PM FINAL
 Site Code : 00000002
 Start Date : 5/23/2013
 Page No : 1

Groups Printed- Bikes

Start Time	TRANSIT CENTER WAY Southbound					1ST AVE Westbound					PARKING GARAGE EXIT Northbound					1ST AVE Eastbound					Int. Total
	Right	Thru	Left	Peds	App. Total	Right	Thru	Left	Peds	App. Total	Right	Thru	Left	Peds	App. Total	Right	Thru	Left	Peds	App. Total	
04:00 PM	0	0	0	0	0	1	0	0	0	1	0	0	0	0	0	0	0	0	0	0	1
04:15 PM	0	0	0	0	0	0	0	0	0	0	0	0	0	0	0	0	0	0	0	0	0
04:30 PM	0	0	0	0	0	1	0	0	0	1	0	0	0	0	0	0	0	0	0	0	1
04:45 PM	0	0	0	0	0	1	0	0	0	1	0	0	0	0	0	0	0	0	0	0	1
Total	0	0	0	0	0	3	0	0	0	3	0	0	0	0	0	0	0	0	0	0	3
05:00 PM	0	0	0	0	0	0	0	0	0	0	0	0	0	0	0	0	0	0	0	0	0
05:15 PM	0	0	0	0	0	1	4	0	0	5	0	0	0	0	0	0	1	1	0	2	7
05:30 PM	0	0	0	0	0	0	1	0	0	1	0	0	0	0	0	0	1	2	0	3	4
05:45 PM	0	0	0	0	0	0	1	0	0	1	0	0	0	0	0	0	0	4	0	4	5
Total	0	0	0	0	0	1	6	0	0	7	0	0	0	0	0	0	2	7	0	9	16
Grand Total	0	0	0	0	0	4	6	0	0	10	0	0	0	0	0	0	2	7	0	9	19
Apprch %	0	0	0	0		40	60	0	0		0	0	0	0		0	22.2	77.8	0		
Total %	0	0	0	0	0	21.1	31.6	0	0	52.6	0	0	0	0	0	0	10.5	36.8	0	47.4	

Start Time	TRANSIT CENTER WAY Southbound				App. Total	1ST AVE Westbound				App. Total	PARKING GARAGE EXIT Northbound				App. Total	1ST AVE Eastbound				Int. Total
	Right	Thru	Left	Peds		Right	Thru	Left	Peds		Right	Thru	Left	Peds		Right	Thru	Left	Peds	
05:00 PM	0	0	0	0	0	0	0	0	0	0	0	0	0	0	0	0	0	0	0	
05:15 PM	0	0	0	0	0	1	4	0	5	5	0	0	0	0	0	0	1	1	2	
05:30 PM	0	0	0	0	0	0	1	0	1	1	0	0	0	0	0	0	1	2	3	
05:45 PM	0	0	0	0	0	0	1	0	1	1	0	0	0	0	0	0	0	4	4	
Total Volume	0	0	0	0	0	1	6	0	7	7	0	0	0	0	0	0	2	7	9	
% App. Total	0	0	0	0		14.3	85.7	0			0	0	0	0		0	22.2	77.8		
PHF	.000	.000	.000	.000	.000	.250	.375	.000	.350	.350	.000	.000	.000	.000	.000	.000	.500	.438	.563	

Peak Hour Analysis From 04:00 PM to 05:45 PM - Peak 1 of 1

Peak Hour for Entire Intersection Begins at 05:00 PM

Traffic Data Service

Campbell, CA

(408) 377-2988

tdsbay@cs.com

File Name : 2PM FINAL

Site Code : 00000002

Start Date : 5/23/2013

Page No : 2

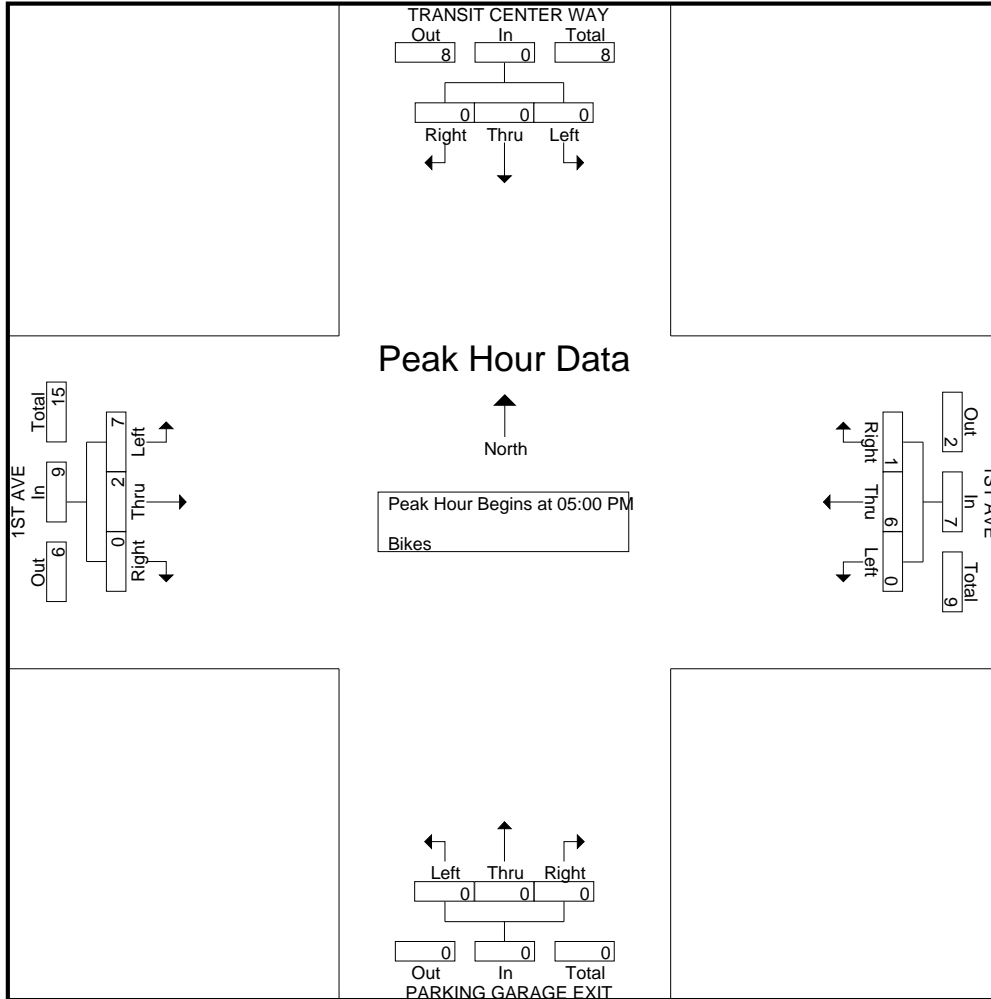

Traffic Data Service

Campbell, CA
 (408) 377-2988
 tdsbay@cs.com

File Name : 7AM FINAL
 Site Code : 00000007
 Start Date : 5/22/2013
 Page No : 1

Groups Printed- Vehicles

Start Time	DRIVEWAY Southbound					CONCAR DR Westbound					SR-92 WB RAMPS Northbound					CONCAR DR Eastbound					Int. Total
	Right	Thru	Left	Peds	App. Total	Right	Thru	Left	Peds	App. Total	Right	Thru	Left	Peds	App. Total	Right	Thru	Left	Peds	App. Total	
07:00 AM	0	1	0	4	5	2	3	64	0	69	121	6	13	0	140	1	2	0	0	3	217
07:15 AM	0	0	0	1	1	2	4	113	0	119	160	12	17	0	189	3	1	0	0	4	313
07:30 AM	0	3	0	3	6	2	5	203	0	210	156	14	5	0	175	5	6	0	0	11	402
07:45 AM	0	2	0	2	4	6	11	203	0	220	169	18	1	0	188	8	2	0	0	10	422
Total	0	6	0	10	16	12	23	583	0	618	606	50	36	0	692	17	11	0	0	28	1354
08:00 AM	1	0	0	22	23	3	5	143	0	151	221	10	9	0	240	6	5	0	0	11	425
08:15 AM	1	4	0	2	7	6	3	140	0	149	177	5	8	0	190	5	0	1	0	6	352
08:30 AM	0	8	1	3	12	8	2	128	0	138	153	15	19	0	187	5	5	1	0	11	348
08:45 AM	0	3	1	4	8	8	6	108	0	122	166	8	31	0	205	7	7	0	0	14	349
Total	2	15	2	31	50	25	16	519	0	560	717	38	67	0	822	23	17	2	0	42	1474
Grand Total	2	21	2	41	66	37	39	1102	0	1178	1323	88	103	0	1514	40	28	2	0	70	2828
Apprch %	3	31.8	3	62.1		3.1	3.3	93.5	0		87.4	5.8	6.8	0		57.1	40	2.9	0		
Total %	0.1	0.7	0.1	1.4	2.3	1.3	1.4	39	0	41.7	46.8	3.1	3.6	0	53.5	1.4	1	0.1	0	2.5	

Start Time	DRIVEWAY Southbound				CONCAR DR Westbound				SR-92 WB RAMPS Northbound				CONCAR DR Eastbound				Int. Total
	Right	Thru	Left	App. Total	Right	Thru	Left	App. Total	Right	Thru	Left	App. Total	Right	Thru	Left	App. Total	
Peak Hour Analysis From 07:00 AM to 08:45 AM - Peak 1 of 1																	
Peak Hour for Entire Intersection Begins at 07:30 AM																	
07:30 AM	0	3	0	3	2	5	203	210	156	14	5	175	5	6	0	11	399
07:45 AM	0	2	0	2	6	11	203	220	169	18	1	188	8	2	0	10	420
08:00 AM	1	0	0	1	3	5	143	151	221	10	9	240	6	5	0	11	403
08:15 AM	1	4	0	5	6	3	140	149	177	5	8	190	5	0	1	6	350
Total Volume	2	9	0	11	17	24	689	730	723	47	23	793	24	13	1	38	1572
% App. Total	18.2	81.8	0		2.3	3.3	94.4		91.2	5.9	2.9		63.2	34.2	2.6		
PHF	.500	.563	.000	.550	.708	.545	.849	.830	.818	.653	.639	.826	.750	.542	.250	.864	.936

Traffic Data Service

Campbell, CA

(408) 377-2988

tdsbay@cs.com

File Name : 7AM FINAL

Site Code : 00000007

Start Date : 5/22/2013

Page No : 2

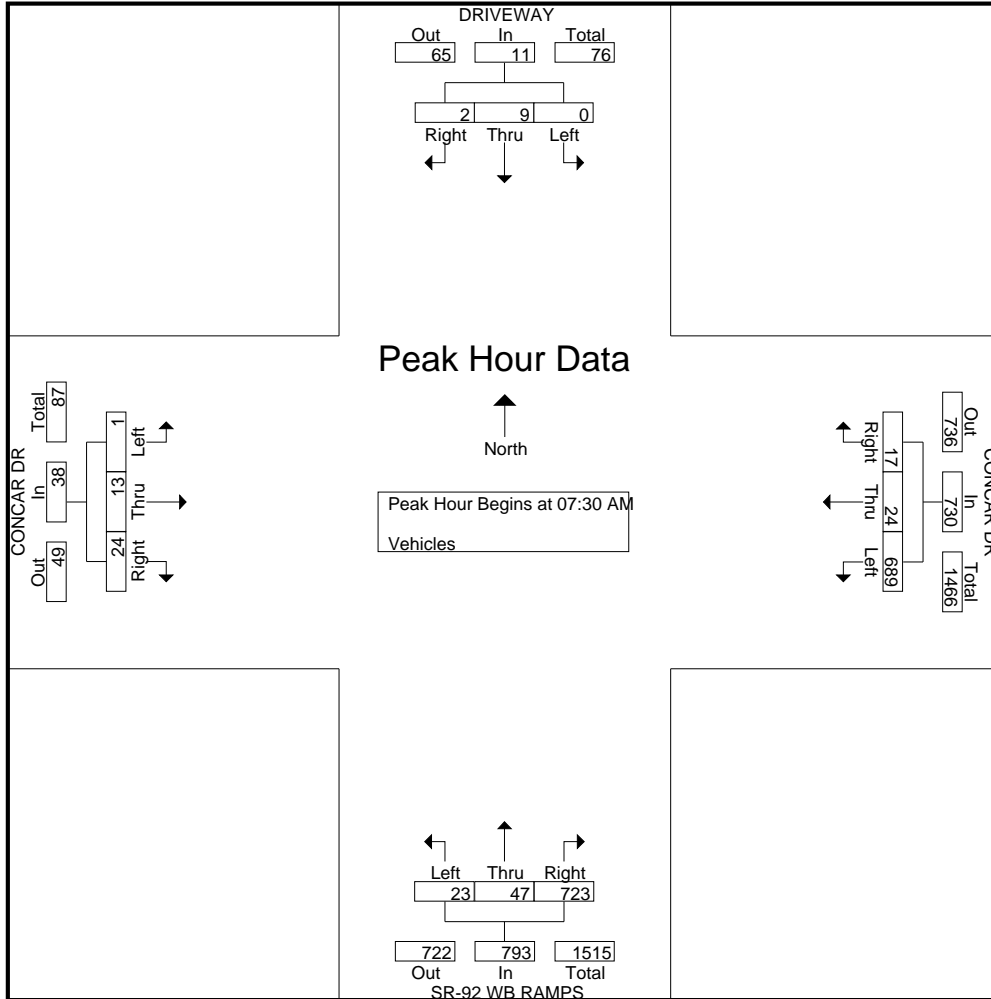

Traffic Data Service

Campbell, CA
 (408) 377-2988
 tdsbay@cs.com

File Name : 7AM FINAL
 Site Code : 00000007
 Start Date : 5/22/2013
 Page No : 1

Groups Printed- Bikes

Start Time	DRIVEWAY Southbound					CONCAR DR Westbound					SR-92 WB RAMPS Northbound					CONCAR DR Eastbound					Int. Total
	Right	Thru	Left	Peds	App. Total	Right	Thru	Left	Peds	App. Total	Right	Thru	Left	Peds	App. Total	Right	Thru	Left	Peds	App. Total	
07:00 AM	0	0	0	0	0	0	0	0	0	0	0	0	0	0	0	0	0	0	0	0	0
07:15 AM	0	0	0	0	0	0	1	0	0	1	0	0	0	0	0	0	0	0	0	0	0
07:30 AM	0	0	0	0	0	0	1	0	0	1	0	0	0	0	0	0	2	0	0	0	2
07:45 AM	0	0	0	0	0	0	2	0	0	2	0	0	0	0	0	0	0	0	0	0	0
Total	0	0	0	0	0	0	4	0	0	4	0	0	0	0	0	0	2	0	0	0	2
08:00 AM	0	0	0	0	0	0	0	0	0	0	0	0	0	0	0	0	0	0	0	0	0
08:15 AM	0	0	0	0	0	0	0	0	0	0	0	0	0	0	0	0	2	0	0	0	2
08:30 AM	0	0	0	0	0	0	0	0	0	0	0	0	0	0	0	0	0	0	0	0	0
08:45 AM	0	0	0	0	0	0	1	0	0	1	0	0	0	0	0	0	2	0	0	0	2
Total	0	0	0	0	0	0	1	0	0	1	0	0	0	0	0	0	4	0	0	0	4
Grand Total	0	0	0	0	0	0	5	0	0	5	0	0	0	0	0	0	6	0	0	0	6
Apprch %	0	0	0	0	0	0	100	0	0	0	0	0	0	0	0	0	100	0	0	0	0
Total %	0	0	0	0	0	0	45.5	0	0	45.5	0	0	0	0	0	0	54.5	0	0	54.5	11

Start Time	DRIVEWAY Southbound				CONCAR DR Westbound				SR-92 WB RAMPS Northbound				CONCAR DR Eastbound				Int. Total
	Right	Thru	Left	App. Total	Right	Thru	Left	App. Total	Right	Thru	Left	App. Total	Right	Thru	Left	App. Total	
07:30 AM	0	0	0	0	0	1	0	1	0	0	0	0	0	2	0	2	3
07:45 AM	0	0	0	0	0	2	0	2	0	0	0	0	0	0	0	0	2
08:00 AM	0	0	0	0	0	0	0	0	0	0	0	0	0	0	0	0	0
08:15 AM	0	0	0	0	0	0	0	0	0	0	0	0	0	2	0	2	2
Total Volume	0	0	0	0	0	3	0	3	0	0	0	0	0	4	0	4	7
% App. Total	0	0	0	0	0	100	0	0	0	0	0	0	0	100	0	0	0
PHF	.000	.000	.000	.000	.000	.375	.000	.375	.000	.000	.000	.000	.000	.500	.000	.500	.583

Peak Hour Analysis From 07:00 AM to 08:45 AM - Peak 1 of 1

Peak Hour for Entire Intersection Begins at 07:30 AM

Traffic Data Service

Campbell, CA

(408) 377-2988

tdsbay@cs.com

File Name : 7AM FINAL

Site Code : 00000007

Start Date : 5/22/2013

Page No : 2

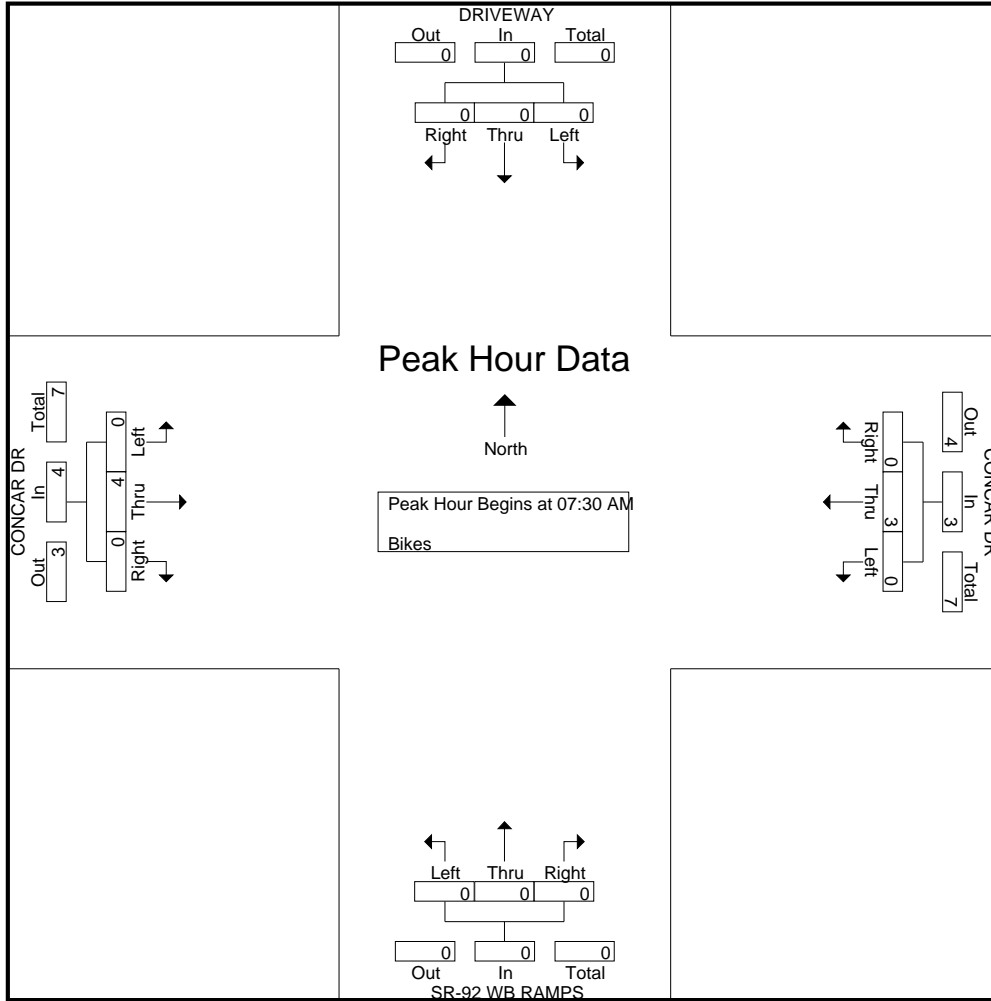

Traffic Data Service

Campbell, CA
 (408) 377-2988
 tdsbay@cs.com

File Name : 7PM FINAL
 Site Code : 00000007
 Start Date : 5/22/2013
 Page No : 1

Groups Printed- Vehicles

Start Time	DRIVEWAY Southbound					CONCAR DR Westbound					SR-92 WB RAMPS Northbound					CONCAR DR Eastbound					Int. Total
	Right	Thru	Left	Peds	App. Total	Right	Thru	Left	Peds	App. Total	Right	Thru	Left	Peds	App. Total	Right	Thru	Left	Peds	App. Total	
04:00 PM	1	8	8	1	18	13	4	149	0	166	105	14	7	0	126	8	6	1	0	15	325
04:15 PM	0	12	2	3	17	9	1	145	0	155	97	5	1	0	103	7	2	1	0	10	285
04:30 PM	1	13	1	5	20	8	7	160	0	175	129	8	5	0	142	6	3	0	0	9	346
04:45 PM	1	10	6	3	20	13	7	137	0	157	131	9	5	0	145	9	14	0	0	23	345
Total	3	43	17	12	75	43	19	591	0	653	462	36	18	0	516	30	25	2	0	57	1301
05:00 PM	2	12	6	1	21	13	9	179	0	201	127	13	2	0	142	16	6	1	0	23	387
05:15 PM	1	10	4	5	20	9	6	153	0	168	138	9	4	0	151	7	6	0	0	13	352
05:30 PM	0	12	4	7	23	6	4	159	0	169	130	9	3	0	142	10	7	0	0	17	351
05:45 PM	0	9	8	10	27	10	5	141	0	156	129	10	7	0	146	12	10	0	0	22	351
Total	3	43	22	23	91	38	24	632	0	694	524	41	16	0	581	45	29	1	0	75	1441
Grand Total	6	86	39	35	166	81	43	1223	0	1347	986	77	34	0	1097	75	54	3	0	132	2742
Apprch %	3.6	51.8	23.5	21.1		6	3.2	90.8	0		89.9	7	3.1	0		56.8	40.9	2.3	0		
Total %	0.2	3.1	1.4	1.3	6.1	3	1.6	44.6	0	49.1	36	2.8	1.2	0	40	2.7	2	0.1	0	4.8	

Start Time	DRIVEWAY Southbound					CONCAR DR Westbound					SR-92 WB RAMPS Northbound					CONCAR DR Eastbound					Int. Total
	Right	Thru	Left	Peds	App. Total	Right	Thru	Left	Peds	App. Total	Right	Thru	Left	Peds	App. Total	Right	Thru	Left	Peds	App. Total	
04:45 PM	1	10	6		17	13	7	137		157	131	9	5		145	9	14	0		23	342
05:00 PM	2	12	6		20	13	9	179		201	127	13	2		142	16	6	1		23	386
05:15 PM	1	10	4		15	9	6	153		168	138	9	4		151	7	6	0		13	347
05:30 PM	0	12	4		16	6	4	159		169	130	9	3		142	10	7	0		17	344
Total Volume	4	44	20		68	41	26	628		695	526	40	14		580	42	33	1		76	1419
% App. Total	5.9	64.7	29.4			5.9	3.7	90.4			90.7	6.9	2.4			55.3	43.4	1.3			
PHF	.500	.917	.833		.850	.788	.722	.877		.864	.953	.769	.700		.960	.656	.589	.250		.826	.919

Peak Hour Analysis From 04:00 PM to 05:45 PM - Peak 1 of 1

Peak Hour for Entire Intersection Begins at 04:45 PM

Traffic Data Service

Campbell, CA

(408) 377-2988

tdsbay@cs.com

File Name : 7PM FINAL

Site Code : 00000007

Start Date : 5/22/2013

Page No : 2

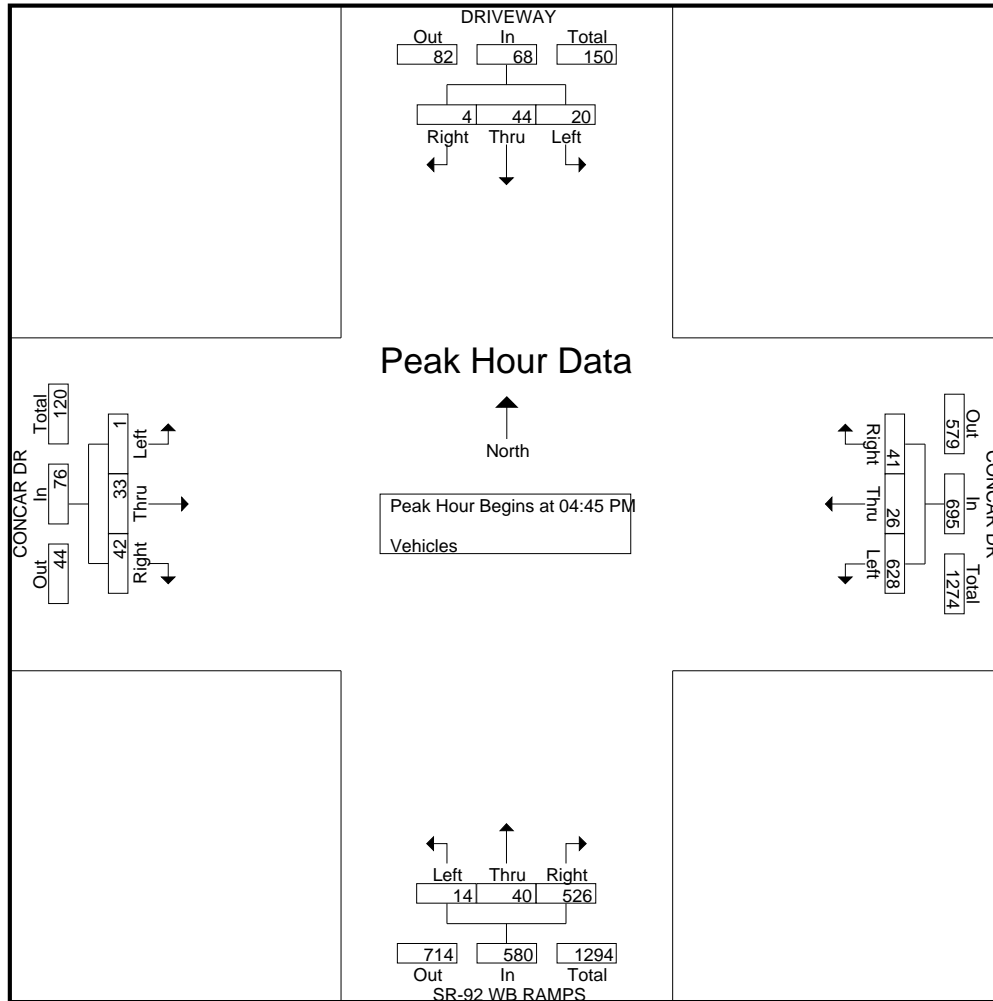

Traffic Data Service

Campbell, CA
 (408) 377-2988
 tdsbay@cs.com

File Name : 7PM FINAL
 Site Code : 00000007
 Start Date : 5/22/2013
 Page No : 1

Groups Printed- Bikes

Start Time	DRIVEWAY Southbound					CONCAR DR Westbound					SR-92 WB RAMPS Northbound					CONCAR DR Eastbound					Int. Total
	Right	Thru	Left	Peds	App. Total	Right	Thru	Left	Peds	App. Total	Right	Thru	Left	Peds	App. Total	Right	Thru	Left	Peds	App. Total	
04:00 PM	0	0	0	0	0	0	0	0	0	0	0	0	0	0	0	0	0	0	0	0	0
04:15 PM	0	0	0	0	0	0	0	0	0	0	0	0	0	0	0	0	0	0	0	0	0
04:30 PM	0	0	0	0	0	0	0	0	0	0	0	0	0	0	0	0	0	0	0	0	0
04:45 PM	0	0	0	0	0	0	0	0	0	0	0	0	0	0	0	0	0	0	0	0	0
Total	0	0	0	0	0	0	0	0	0	0	0	0	0	0	0	0	0	0	0	0	0
05:00 PM	0	0	0	0	0	0	0	0	0	0	0	0	0	0	0	0	0	0	0	0	0
05:15 PM	0	0	0	0	0	0	1	0	0	1	0	0	0	0	0	0	0	0	0	0	1
05:30 PM	0	0	0	0	0	0	3	0	0	3	0	0	0	0	0	0	1	0	0	1	4
05:45 PM	0	0	0	0	0	0	1	0	0	1	1	0	0	0	1	0	1	0	0	1	3
Total	0	0	0	0	0	0	5	0	0	5	1	0	0	0	1	0	2	0	0	2	8
Grand Total	0	0	0	0	0	0	5	0	0	5	1	0	0	0	1	0	2	0	0	2	8
Apprch %	0	0	0	0	0	0	100	0	0	100	100	0	0	0	100	0	100	0	0	100	
Total %	0	0	0	0	0	0	62.5	0	0	62.5	12.5	0	0	0	12.5	0	25	0	0	25	

Start Time	DRIVEWAY Southbound				CONCAR DR Westbound				SR-92 WB RAMPS Northbound				CONCAR DR Eastbound				Int. Total
	Right	Thru	Left	App. Total	Right	Thru	Left	App. Total	Right	Thru	Left	App. Total	Right	Thru	Left	App. Total	
05:00 PM	0	0	0	0	0	0	0	0	0	0	0	0	0	0	0	0	
05:15 PM	0	0	0	0	0	1	0	1	0	0	0	0	0	0	0	0	
05:30 PM	0	0	0	0	0	3	0	3	0	0	0	0	0	1	0	1	
05:45 PM	0	0	0	0	0	1	0	1	1	0	0	1	0	1	0	1	
Total Volume	0	0	0	0	0	5	0	5	1	0	0	1	0	2	0	2	
% App. Total	0	0	0	0	0	100	0	100	100	0	0	100	0	100	0	100	
PHF	.000	.000	.000	.000	.000	.417	.000	.417	.250	.000	.000	.250	.000	.500	.000	.500	

Peak Hour Analysis From 04:00 PM to 05:45 PM - Peak 1 of 1

Peak Hour for Entire Intersection Begins at 05:00 PM

Traffic Data Service

Campbell, CA

(408) 377-2988

tdsbay@cs.com

File Name : 7PM FINAL

Site Code : 00000007

Start Date : 5/22/2013

Page No : 2

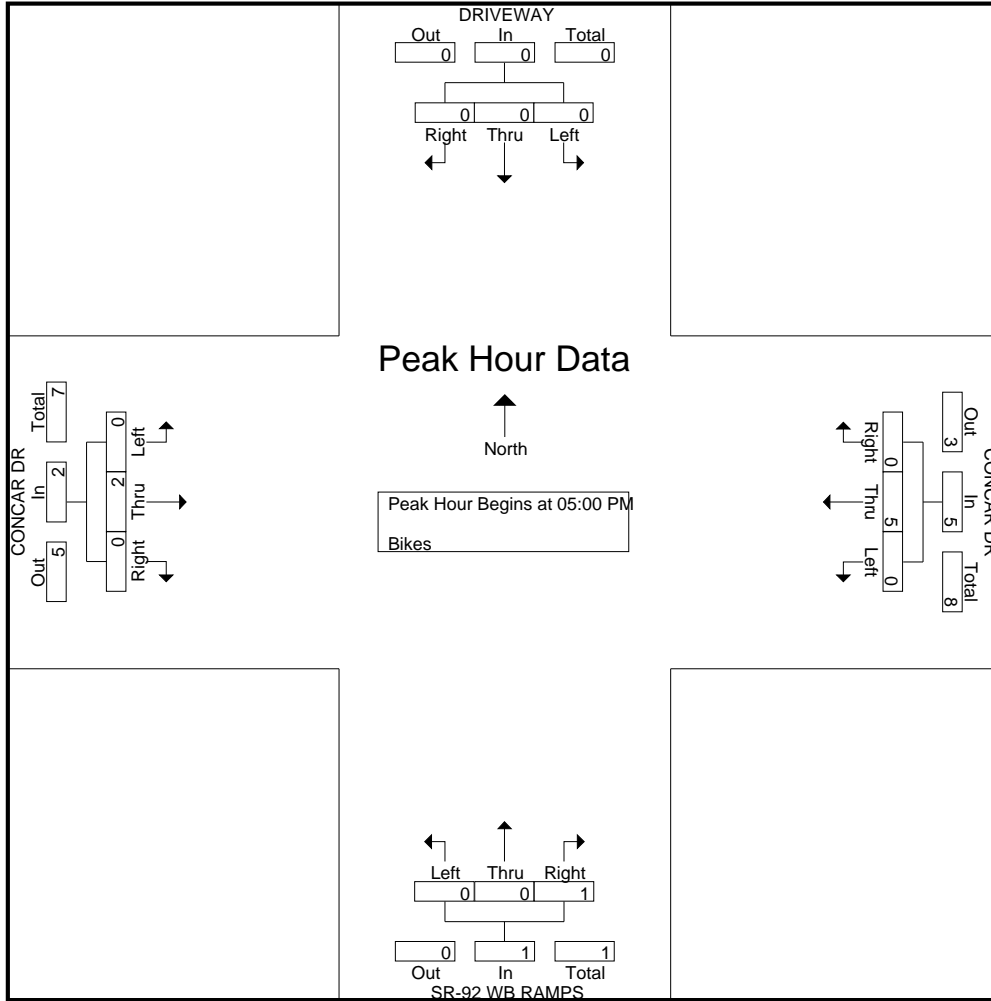

Traffic Data Service

Campbell, CA
 (408) 377-2988
 tdsbay@cs.com

File Name : 54AM FINAL
 Site Code : 00000054
 Start Date : 6/4/2013
 Page No : 1

Groups Printed- Vehicles

Start Time	S. DELAWARE ST Southbound					Westbound					S. DELAWARE ST Northbound					E. 25TH AVE Eastbound					Int. Total
	Right	Thru	Left	Peds	App. Total	Right	Thru	Left	Peds	App. Total	Right	Thru	Left	Peds	App. Total	Right	Thru	Left	Peds	App. Total	
07:00 AM	40	15	0	2	57	0	0	0	0	0	0	2	0	1	3	0	0	34	0	34	94
07:15 AM	50	4	0	0	54	0	0	0	0	0	0	4	0	0	4	0	0	33	1	34	92
07:30 AM	93	2	0	0	95	0	0	0	0	0	0	3	2	1	6	1	0	61	0	62	163
07:45 AM	139	9	1	3	152	0	0	0	0	0	0	2	3	0	5	5	0	98	1	104	261
Total	322	30	1	5	358	0	0	0	0	0	0	11	5	2	18	6	0	226	2	234	610
08:00 AM	111	6	0	0	117	0	0	0	0	0	0	2	1	1	4	8	0	141	1	150	271
08:15 AM	121	7	0	0	128	0	0	0	0	0	0	2	2	0	4	13	0	113	1	127	259
08:30 AM	98	5	1	0	104	0	0	0	0	0	0	4	0	0	4	6	0	80	0	86	194
08:45 AM	99	7	0	1	107	0	0	0	0	0	0	4	2	0	6	3	0	90	0	93	206
Total	429	25	1	1	456	0	0	0	0	0	0	12	5	1	18	30	0	424	2	456	930
Grand Total	751	55	2	6	814	0	0	0	0	0	0	23	10	3	36	36	0	650	4	690	1540
Apprch %	92.3	6.8	0.2	0.7		0	0	0	0	0	0	63.9	27.8	8.3		5.2	0	94.2	0.6		
Total %	48.8	3.6	0.1	0.4	52.9	0	0	0	0	0	0	1.5	0.6	0.2	2.3	2.3	0	42.2	0.3	44.8	

Start Time	S. DELAWARE ST Southbound					Westbound					S. DELAWARE ST Northbound					E. 25TH AVE Eastbound					Int. Total
	Right	Thru	Left	Peds	App. Total	Right	Thru	Left	Peds	App. Total	Right	Thru	Left	Peds	App. Total	Right	Thru	Left	Peds	App. Total	
07:45 AM	139	9	1	3	149	0	0	0	0	0	0	2	3	5	5	0	98	1	103	257	
08:00 AM	111	6	0	0	117	0	0	0	0	0	0	2	1	3	8	0	141	1	149	269	
08:15 AM	121	7	0	0	128	0	0	0	0	0	0	2	2	4	13	0	113	1	126	258	
08:30 AM	98	5	1	0	104	0	0	0	0	0	0	4	0	4	6	0	80	0	86	194	
Total Volume	469	27	2	3	498	0	0	0	0	0	0	10	6	16	32	0	432	2	464	978	
% App. Total	94.2	5.4	0.4	0.6		0	0	0	0	0	0	62.5	37.5	10.0	6.9	0	93.1	0.6			
PHF	.844	.750	.500	.836		.000	.000	.000	.000	.000	.000	.625	.500	.800	.615	.000	.766	.779		.909	

Peak Hour Analysis From 07:00 AM to 08:45 AM - Peak 1 of 1

Peak Hour for Entire Intersection Begins at 07:45 AM

Traffic Data Service

Campbell, CA
 (408) 377-2988
 tdsbay@cs.com

File Name : 54AM FINAL
 Site Code : 00000054
 Start Date : 6/4/2013
 Page No : 2

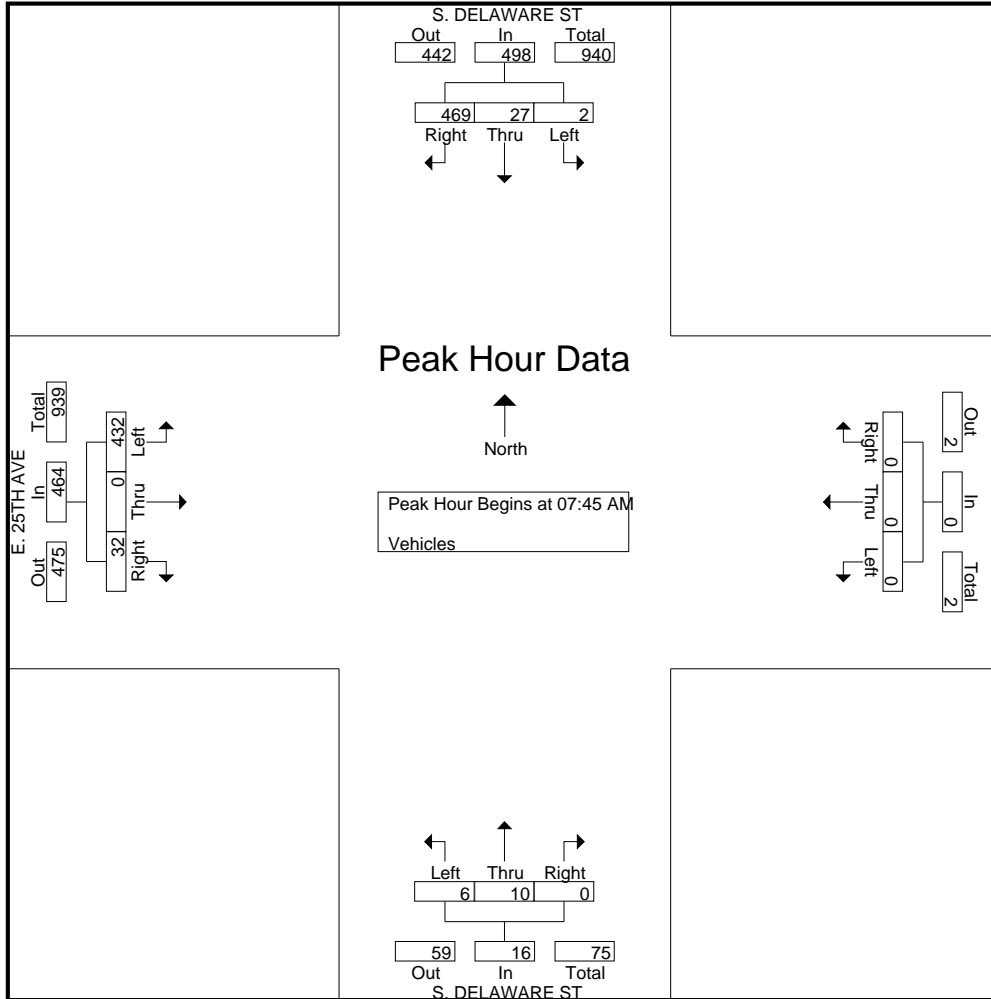

Traffic Data Service

Campbell, CA
 (408) 377-2988
 tdsbay@cs.com

File Name : 54AM FINAL
 Site Code : 00000054
 Start Date : 6/4/2013
 Page No : 1

Groups Printed- Bikes

Start Time	S. DELAWARE ST Southbound					Westbound					S. DELAWARE ST Northbound					E. 25TH AVE Eastbound					Int. Total
	Right	Thru	Left	Peds	App. Total	Right	Thru	Left	Peds	App. Total	Right	Thru	Left	Peds	App. Total	Right	Thru	Left	Peds	App. Total	
07:00 AM	0	0	0	0	0	0	0	0	0	0	0	2	1	0	3	1	0	0	0	1	4
07:15 AM	0	2	0	0	2	0	0	0	0	0	0	0	0	0	0	1	0	0	0	1	3
07:30 AM	0	0	0	0	0	0	0	0	0	0	0	2	0	0	2	2	0	1	0	3	5
07:45 AM	0	0	0	0	0	0	0	0	0	0	0	1	3	0	4	1	0	0	0	1	5
Total	0	2	0	0	2	0	0	0	0	0	0	5	4	0	9	5	0	1	0	6	17
08:00 AM	0	4	0	0	4	0	0	0	0	0	0	3	0	0	3	0	0	0	0	0	7
08:15 AM	2	0	0	0	2	0	0	0	0	0	0	6	3	0	9	0	0	1	0	1	12
08:30 AM	1	2	0	0	3	0	0	0	0	0	0	9	2	0	11	1	0	2	0	3	17
08:45 AM	0	4	0	0	4	0	0	0	0	0	0	2	2	0	4	0	0	0	0	0	8
Total	3	10	0	0	13	0	0	0	0	0	0	20	7	0	27	1	0	3	0	4	44
Grand Total	3	12	0	0	15	0	0	0	0	0	0	25	11	0	36	6	0	4	0	10	61
Apprch %	20	80	0	0		0	0	0	0		0	69.4	30.6	0		60	0	40	0		
Total %	4.9	19.7	0	0	24.6	0	0	0	0	0	0	41	18	0	59	9.8	0	6.6	0	16.4	

Start Time	S. DELAWARE ST Southbound				Westbound				S. DELAWARE ST Northbound				E. 25TH AVE Eastbound				Int. Total
	Right	Thru	Left	App. Total	Right	Thru	Left	App. Total	Right	Thru	Left	App. Total	Right	Thru	Left	App. Total	
Peak Hour Analysis From 07:00 AM to 08:45 AM - Peak 1 of 1																	
Peak Hour for Entire Intersection Begins at 08:00 AM																	
08:00 AM	0	4	0	4	0	0	0	0	0	3	0	3	0	0	0	0	7
08:15 AM	2	0	0	2	0	0	0	0	0	6	3	9	0	0	1	1	12
08:30 AM	1	2	0	3	0	0	0	0	0	9	2	11	1	0	2	3	17
08:45 AM	0	4	0	4	0	0	0	0	0	2	2	4	0	0	0	0	8
Total Volume	3	10	0	13	0	0	0	0	0	20	7	27	1	0	3	4	44
% App. Total	23.1	76.9	0		0	0	0		0	74.1	25.9		25	0	75		
PHF	.375	.625	.000	.813	.000	.000	.000	.000	.000	.556	.583	.614	.250	.000	.375	.333	.647

Traffic Data Service

Campbell, CA
(408) 377-2988
tdsbay@cs.com

File Name : 54AM FINAL
Site Code : 00000054
Start Date : 6/4/2013
Page No : 2

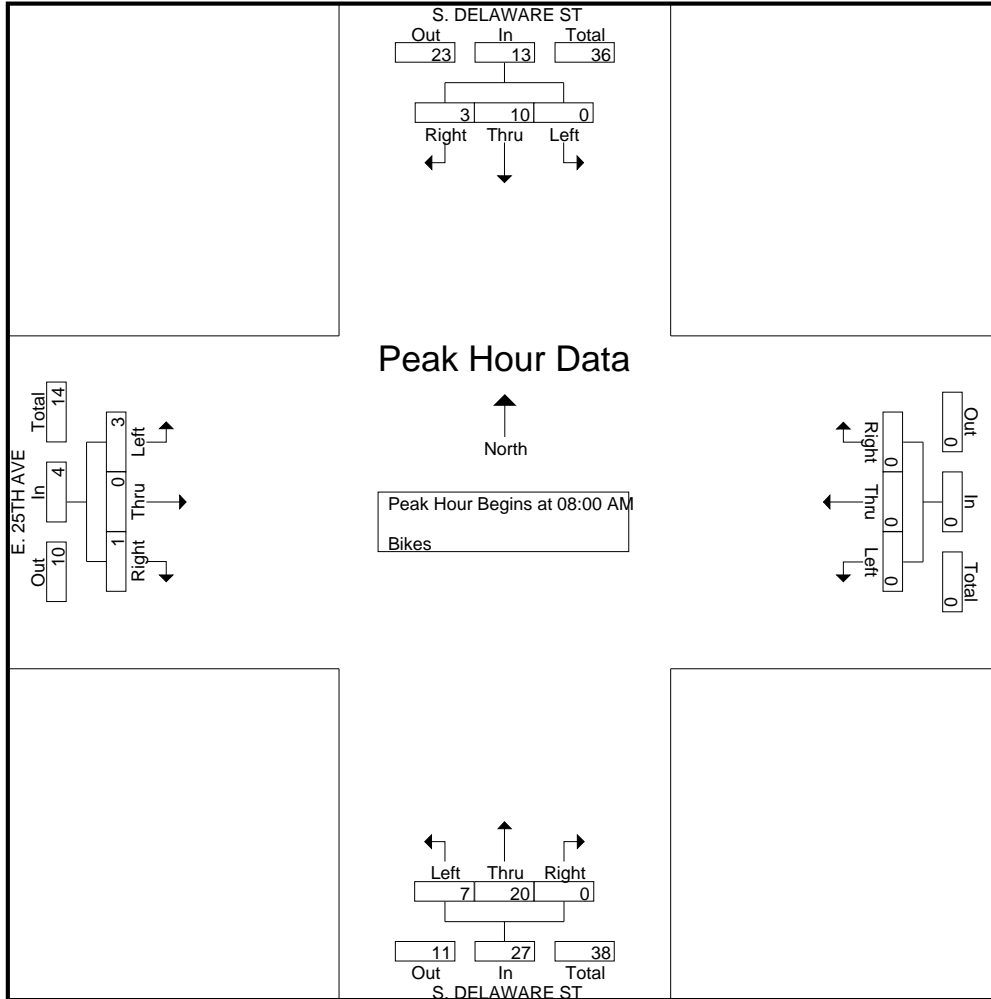

Traffic Data Service

Campbell, CA
 (408) 377-2988
 tdsbay@cs.com

File Name : 54PM FINAL
 Site Code : 00000054
 Start Date : 6/4/2013
 Page No : 1

Groups Printed- Vehicles

Start Time	S. DELAWARE ST Southbound					Westbound					S. DELAWARE ST Northbound					E. 25TH AVE Eastbound					Int. Total
	Right	Thru	Left	Peds	App. Total	Right	Thru	Left	Peds	App. Total	Right	Thru	Left	Peds	App. Total	Right	Thru	Left	Peds	App. Total	
04:00 PM	128	1	0	3	132	0	0	0	0	0	0	2	4	3	9	4	0	101	0	105	246
04:15 PM	108	0	0	0	108	0	0	0	0	0	0	2	0	13	15	2	0	125	0	127	250
04:30 PM	121	1	0	4	126	0	0	0	0	0	0	3	1	1	5	4	0	125	0	129	260
04:45 PM	122	1	0	1	124	0	0	0	0	0	0	1	2	11	14	1	0	135	0	136	274
Total	479	3	0	8	490	0	0	0	0	0	0	8	7	28	43	11	0	486	0	497	1030
05:00 PM	145	1	0	3	149	0	0	0	0	0	0	3	3	1	7	4	0	136	0	140	296
05:15 PM	147	4	0	2	153	0	0	0	0	0	0	1	3	6	10	5	0	126	0	131	294
05:30 PM	119	3	0	4	126	0	0	0	0	0	0	3	0	6	9	5	0	123	0	128	263
05:45 PM	142	2	0	10	154	0	0	0	0	0	0	1	3	1	5	4	0	103	1	108	267
Total	553	10	0	19	582	0	0	0	0	0	0	8	9	14	31	18	0	488	1	507	1120
Grand Total	1032	13	0	27	1072	0	0	0	0	0	0	16	16	42	74	29	0	974	1	1004	2150
Apprch %	96.3	1.2	0	2.5		0	0	0	0	0	0	21.6	21.6	56.8		2.9	0	97	0.1		
Total %	48	0.6	0	1.3	49.9	0	0	0	0	0	0	0.7	0.7	2	3.4	1.3	0	45.3	0	46.7	

Start Time	S. DELAWARE ST Southbound					Westbound					S. DELAWARE ST Northbound					E. 25TH AVE Eastbound					Int. Total
	Right	Thru	Left	Peds	App. Total	Right	Thru	Left	Peds	App. Total	Right	Thru	Left	Peds	App. Total	Right	Thru	Left	Peds	App. Total	
Peak Hour Analysis From 04:00 PM to 05:45 PM - Peak 1 of 1																					
Peak Hour for Entire Intersection Begins at 04:30 PM																					
04:30 PM	121	1	0	0	122	0	0	0	0	0	0	3	1	4	4	0	125	0	129	255	
04:45 PM	122	1	0	0	123	0	0	0	0	0	0	1	2	3	1	0	135	0	136	262	
05:00 PM	145	1	0	0	146	0	0	0	0	0	0	3	3	6	4	0	136	0	140	292	
05:15 PM	147	4	0	0	151	0	0	0	0	0	0	1	3	4	5	0	126	0	131	286	
Total Volume	535	7	0	0	542	0	0	0	0	0	0	8	9	17	14	0	522	0	536	1095	
% App. Total	98.7	1.3	0	0		0	0	0	0	0	0	47.1	52.9		2.6	0	97.4	0			
PHF	.910	.438	.000	.000	.897	.000	.000	.000	.000	.000	.000	.667	.750	.708	.700	.000	.960	.000	.957	.938	

Traffic Data Service

Campbell, CA
(408) 377-2988
tdsbay@cs.com

File Name : 54PM FINAL
Site Code : 00000054
Start Date : 6/4/2013
Page No : 2

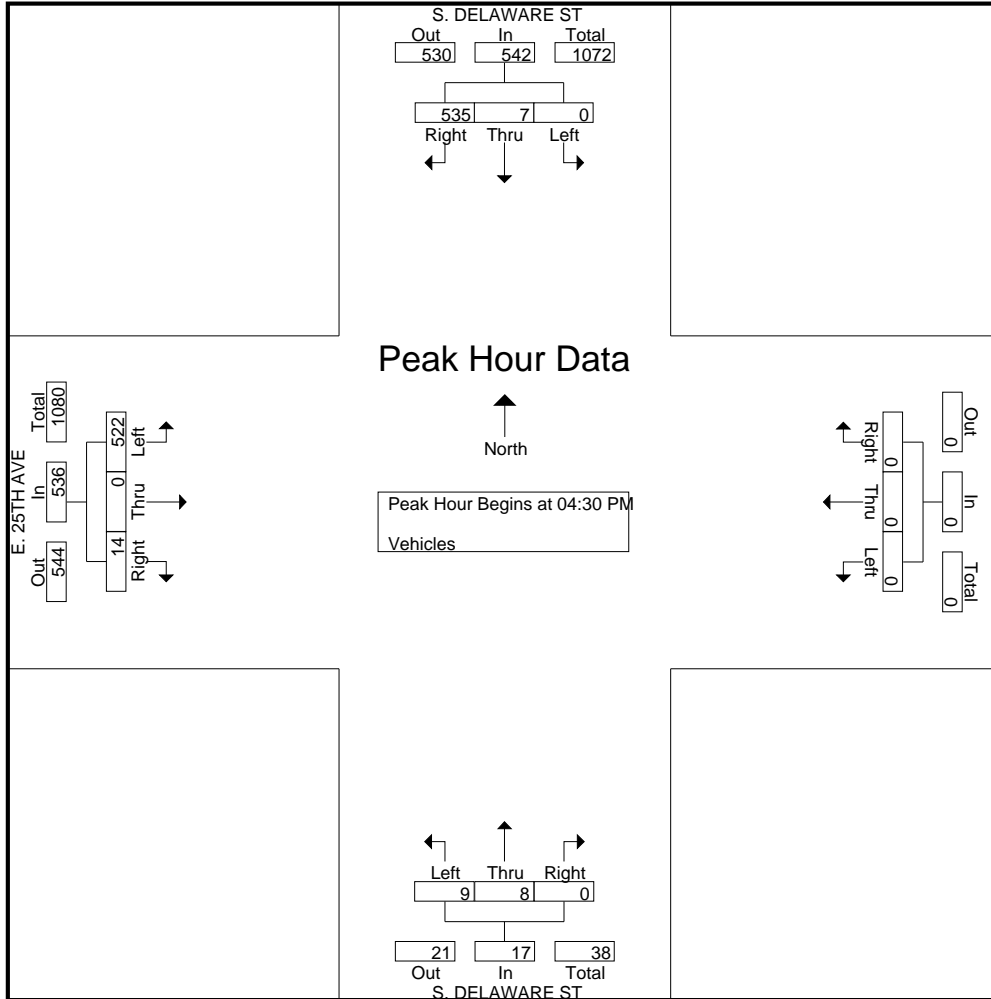

Traffic Data Service

Campbell, CA
 (408) 377-2988
 tdsbay@cs.com

File Name : 54PM FINAL
 Site Code : 00000054
 Start Date : 6/4/2013
 Page No : 1

Groups Printed- Bikes

Start Time	S. DELAWARE ST Southbound					Westbound					S. DELAWARE ST Northbound					E. 25TH AVE Eastbound					Int. Total
	Right	Thru	Left	Peds	App. Total	Right	Thru	Left	Peds	App. Total	Right	Thru	Left	Peds	App. Total	Right	Thru	Left	Peds	App. Total	
04:00 PM	0	0	0	0	0	0	0	0	0	0	0	0	0	0	0	0	0	1	0	1	1
04:15 PM	1	4	0	0	5	0	0	0	0	0	0	0	0	0	0	0	0	0	0	0	5
04:30 PM	0	0	0	0	0	0	0	0	0	0	0	1	1	0	2	0	0	0	0	0	2
04:45 PM	0	1	0	0	1	0	0	0	0	0	0	1	0	0	1	0	0	1	0	1	3
Total	1	5	0	0	6	0	0	0	0	0	0	2	1	0	3	0	0	2	0	2	11
05:00 PM	0	9	0	0	9	0	0	0	0	0	0	3	1	0	4	3	0	1	0	4	17
05:15 PM	0	2	0	0	2	0	0	0	0	0	0	2	0	0	2	1	0	0	0	1	5
05:30 PM	1	1	0	0	2	0	0	0	0	0	0	1	1	0	2	1	0	1	0	2	6
05:45 PM	3	7	0	0	10	0	0	0	0	0	0	1	1	0	2	1	0	0	0	1	13
Total	4	19	0	0	23	0	0	0	0	0	0	7	3	0	10	6	0	2	0	8	41
Grand Total	5	24	0	0	29	0	0	0	0	0	0	9	4	0	13	6	0	4	0	10	52
Apprch %	17.2	82.8	0	0		0	0	0	0		0	69.2	30.8	0		60	0	40	0		
Total %	9.6	46.2	0	0	55.8	0	0	0	0	0	0	17.3	7.7	0	25	11.5	0	7.7	0	19.2	

Start Time	S. DELAWARE ST Southbound					Westbound					S. DELAWARE ST Northbound					E. 25TH AVE Eastbound					Int. Total
	Right	Thru	Left	Peds	App. Total	Right	Thru	Left	Peds	App. Total	Right	Thru	Left	Peds	App. Total	Right	Thru	Left	Peds	App. Total	
05:00 PM	0	9	0	0	9	0	0	0	0	0	0	3	1	0	4	3	0	1	0	4	17
05:15 PM	0	2	0	0	2	0	0	0	0	0	0	2	0	0	2	1	0	0	0	1	5
05:30 PM	1	1	0	0	2	0	0	0	0	0	0	1	1	0	2	1	0	1	0	2	6
05:45 PM	3	7	0	0	10	0	0	0	0	0	0	1	1	0	2	1	0	0	0	1	13
Total Volume	4	19	0	0	23	0	0	0	0	0	0	7	3	0	10	6	0	2	0	8	41
% App. Total	17.4	82.6	0	0		0	0	0	0		0	70	30	0		75	0	25	0		
PHF	.333	.528	.000	.000	.575	.000	.000	.000	.000	.000	.000	.583	.750	.625	.625	.500	.000	.500	.500	.500	.603

Peak Hour Analysis From 04:00 PM to 05:45 PM - Peak 1 of 1

Peak Hour for Entire Intersection Begins at 05:00 PM

Traffic Data Service

Campbell, CA
 (408) 377-2988
 tdsbay@cs.com

File Name : 54PM FINAL
 Site Code : 00000054
 Start Date : 6/4/2013
 Page No : 2

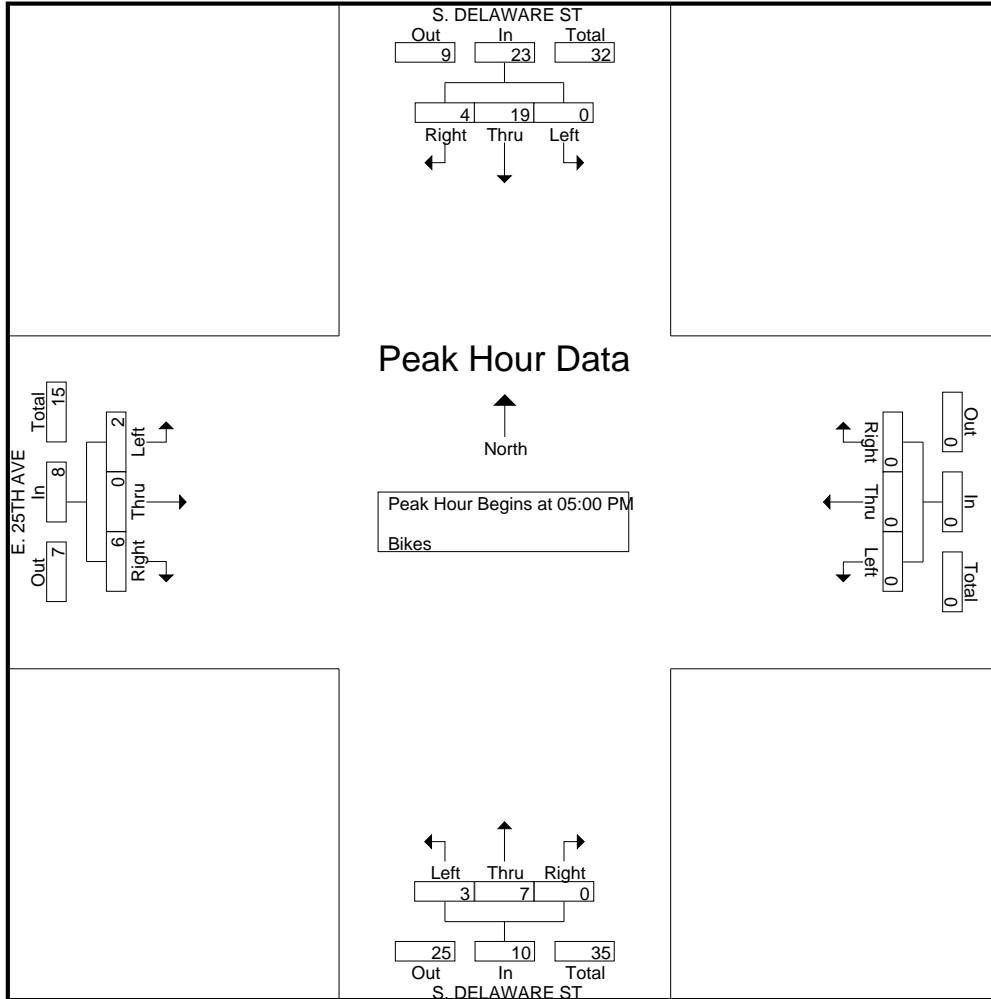

Traffic Data Service

Campbell, CA
 (408) 377-2988
 tdsbay@cs.com

File Name : 55AM FINAL
 Site Code : 00000055
 Start Date : 6/4/2013
 Page No : 1

Groups Printed- Vehicles

Start Time	EL CAMINO REAL Southbound					E. 25TH AVE Westbound					EL CAMINO REAL Northbound					W. 25TH AVE Eastbound					Int. Total
	Right	Thru	Left	Peds	App. Total	Right	Thru	Left	Peds	App. Total	Right	Thru	Left	Peds	App. Total	Right	Thru	Left	Peds	App. Total	
07:00 AM	6	146	5	4	161	8	2	33	0	43	17	93	4	0	114	4	13	21	1	39	357
07:15 AM	6	175	14	2	197	3	14	36	1	54	18	139	2	0	159	1	9	17	2	29	439
07:30 AM	6	225	16	6	253	11	26	61	1	99	39	208	5	0	252	3	13	36	5	57	661
07:45 AM	17	270	18	2	307	17	30	96	5	148	83	287	9	0	379	3	37	39	2	81	915
Total	35	816	53	14	918	39	72	226	7	344	157	727	20	0	904	11	72	113	10	206	2372
08:00 AM	12	282	23	2	319	18	26	93	2	139	96	256	10	0	362	10	46	35	4	95	915
08:15 AM	13	261	12	3	289	10	37	103	2	152	94	258	8	0	360	9	39	35	2	85	886
08:30 AM	13	253	19	3	288	16	23	72	0	111	51	211	10	0	272	14	39	39	2	94	765
08:45 AM	26	267	21	4	318	22	24	72	3	121	63	253	18	0	334	8	29	22	6	65	838
Total	64	1063	75	12	1214	66	110	340	7	523	304	978	46	0	1328	41	153	131	14	339	3404
Grand Total	99	1879	128	26	2132	105	182	566	14	867	461	1705	66	0	2232	52	225	244	24	545	5776
Apprch %	4.6	88.1	6	1.2		12.1	21	65.3	1.6		20.7	76.4	3	0		9.5	41.3	44.8	4.4		
Total %	1.7	32.5	2.2	0.5	36.9	1.8	3.2	9.8	0.2	15	8	29.5	1.1	0	38.6	0.9	3.9	4.2	0.4	9.4	

Start Time	EL CAMINO REAL Southbound				E. 25TH AVE Westbound				EL CAMINO REAL Northbound				W. 25TH AVE Eastbound				Int. Total
	Right	Thru	Left	App. Total	Right	Thru	Left	App. Total	Right	Thru	Left	App. Total	Right	Thru	Left	App. Total	
07:45 AM	17	270	18	305	17	30	96	143	83	287	9	379	3	37	39	79	906
08:00 AM	12	282	23	317	18	26	93	137	96	256	10	362	10	46	35	91	907
08:15 AM	13	261	12	286	10	37	103	150	94	258	8	360	9	39	35	83	879
08:30 AM	13	253	19	285	16	23	72	111	51	211	10	272	14	39	39	92	760
Total Volume	55	1066	72	1193	61	116	364	541	324	1012	37	1373	36	161	148	345	3452
% App. Total	4.6	89.4	6		11.3	21.4	67.3		23.6	73.7	2.7		10.4	46.7	42.9		
PHF	.809	.945	.783	.941	.847	.784	.883	.902	.844	.882	.925	.906	.643	.875	.949	.938	.951

Peak Hour Analysis From 07:00 AM to 08:45 AM - Peak 1 of 1

Peak Hour for Entire Intersection Begins at 07:45 AM

Traffic Data Service

Campbell, CA
(408) 377-2988
tdsbay@cs.com

File Name : 55AM FINAL
Site Code : 00000055
Start Date : 6/4/2013
Page No : 2

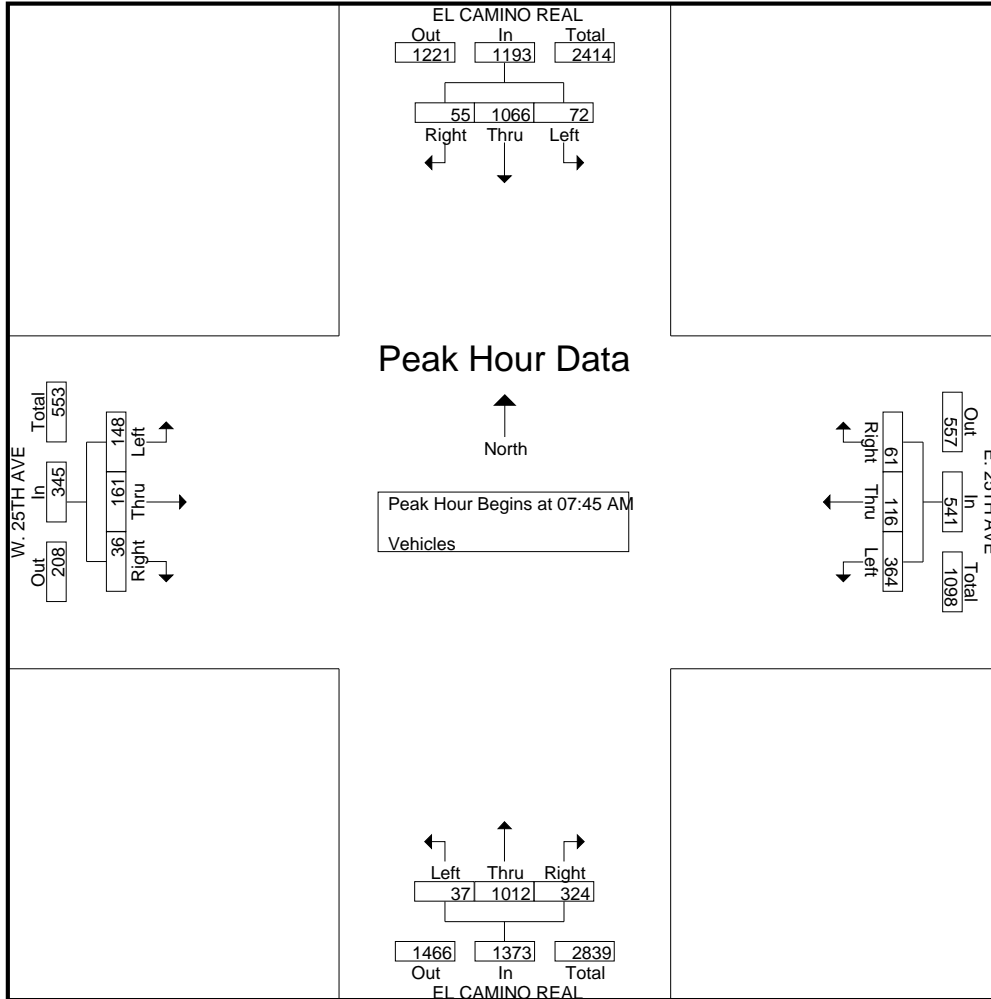

Traffic Data Service

Campbell, CA
 (408) 377-2988
 tdsbay@cs.com

File Name : 55AM FINAL
 Site Code : 00000055
 Start Date : 6/4/2013
 Page No : 1

Groups Printed- Bikes

Start Time	EL CAMINO REAL Southbound					E. 25TH AVE Westbound					EL CAMINO REAL Northbound					W. 25TH AVE Eastbound					Int. Total
	Right	Thru	Left	Peds	App. Total	Right	Thru	Left	Peds	App. Total	Right	Thru	Left	Peds	App. Total	Right	Thru	Left	Peds	App. Total	
07:00 AM	0	1	0	0	1	0	0	0	0	0	0	0	0	0	0	0	0	0	0	0	0
07:15 AM	0	0	0	0	0	0	1	0	0	1	0	0	0	0	0	0	1	0	0	0	1
07:30 AM	0	1	0	0	1	0	0	0	0	0	0	1	0	0	1	0	1	0	0	0	1
07:45 AM	0	0	0	0	0	0	0	0	0	0	0	0	0	0	0	0	0	0	0	0	0
Total	0	2	0	0	2	0	1	0	0	1	0	1	0	0	1	0	2	0	0	0	2
08:00 AM	0	0	0	0	0	0	1	0	0	1	0	0	0	0	0	0	0	0	0	0	0
08:15 AM	0	0	0	0	0	0	1	1	0	2	0	0	0	0	0	0	1	0	0	0	1
08:30 AM	0	0	0	0	0	0	1	1	0	2	1	0	0	0	1	1	0	0	0	0	1
08:45 AM	0	0	0	0	0	0	0	0	0	0	0	0	0	0	0	0	0	0	0	0	0
Total	0	0	0	0	0	0	3	2	0	5	1	0	0	0	1	1	1	0	0	0	2
Grand Total	0	2	0	0	2	0	4	2	0	6	1	1	0	0	2	1	3	0	0	0	4
Apprch %	0	100	0	0		0	66.7	33.3	0		50	50	0	0		25	75	0	0		
Total %	0	14.3	0	0	14.3	0	28.6	14.3	0	42.9	7.1	7.1	0	0	14.3	7.1	21.4	0	0	28.6	

Start Time	EL CAMINO REAL Southbound					E. 25TH AVE Westbound					EL CAMINO REAL Northbound					W. 25TH AVE Eastbound					Int. Total
	Right	Thru	Left	Peds	App. Total	Right	Thru	Left	Peds	App. Total	Right	Thru	Left	Peds	App. Total	Right	Thru	Left	Peds	App. Total	
07:45 AM	0	0	0	0	0	0	0	0	0	0	0	0	0	0	0	0	0	0	0	0	0
08:00 AM	0	0	0	0	0	0	1	0	0	1	0	0	0	0	0	0	0	0	0	0	0
08:15 AM	0	0	0	0	0	0	1	1	0	2	0	0	0	0	0	0	1	0	0	0	1
08:30 AM	0	0	0	0	0	0	1	1	0	2	1	0	0	0	1	1	0	0	0	0	1
Total Volume	0	0	0	0	0	0	3	2	0	5	1	0	0	0	1	1	1	0	0	0	2
% App. Total	0	0	0	0		0	60	40	0		100	0	0	0		50	50	0	0		
PHF	.000	.000	.000	.000	.000	.000	.750	.500	.625		.250	.000	.000	.250		.250	.250	.000	.500		.500

Peak Hour Analysis From 07:00 AM to 08:45 AM - Peak 1 of 1

Peak Hour for Entire Intersection Begins at 07:45 AM

Traffic Data Service

Campbell, CA
 (408) 377-2988
 tdsbay@cs.com

File Name : 55AM FINAL
 Site Code : 00000055
 Start Date : 6/4/2013
 Page No : 2

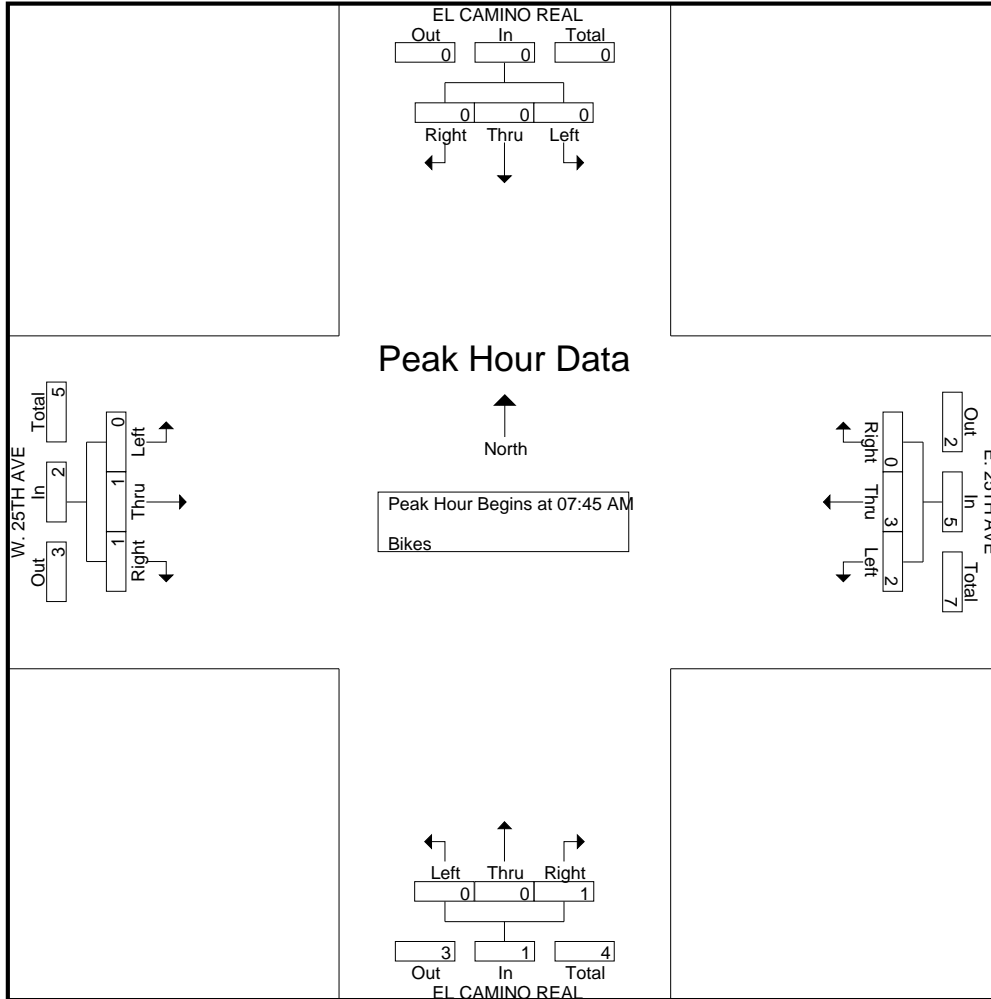

Traffic Data Service

Campbell, CA
 (408) 377-2988
 tdsbay@cs.com

File Name : 55PM FINAL
 Site Code : 00000055
 Start Date : 6/4/2013
 Page No : 1

Groups Printed- Vehicles

Start Time	EL CAMINO REAL Southbound					E. 25TH AVE Westbound					EL CAMINO REAL Northbound					W. 25TH AVE Eastbound					Int. Total
	Right	Thru	Left	Peds	App. Total	Right	Thru	Left	Peds	App. Total	Right	Thru	Left	Peds	App. Total	Right	Thru	Left	Peds	App. Total	
04:00 PM	39	295	22	8	364	24	41	80	4	149	77	330	20	0	427	13	28	33	6	80	1020
04:15 PM	32	282	31	11	356	20	39	67	8	134	84	312	24	0	420	15	34	45	10	104	1014
04:30 PM	30	273	24	9	336	20	34	74	2	130	86	318	20	0	424	12	24	34	7	77	967
04:45 PM	22	272	30	6	330	26	29	80	1	136	86	308	25	0	419	18	24	51	7	100	985
Total	123	1122	107	34	1386	90	143	301	15	549	333	1268	89	0	1690	58	110	163	30	361	3986
05:00 PM	25	325	34	10	394	27	38	95	0	160	80	351	24	0	455	13	24	59	10	106	1115
05:15 PM	30	326	38	10	404	31	54	95	0	180	80	433	21	0	534	11	30	52	3	96	1214
05:30 PM	39	317	21	12	389	28	38	85	0	151	79	396	29	0	504	16	33	56	3	108	1152
05:45 PM	23	313	33	23	392	23	53	99	1	176	74	321	21	0	416	11	32	47	0	90	1074
Total	117	1281	126	55	1579	109	183	374	1	667	313	1501	95	0	1909	51	119	214	16	400	4555
Grand Total	240	2403	233	89	2965	199	326	675	16	1216	646	2769	184	0	3599	109	229	377	46	761	8541
Apprch %	8.1	81	7.9	3		16.4	26.8	55.5	1.3		17.9	76.9	5.1	0		14.3	30.1	49.5	6		
Total %	2.8	28.1	2.7	1	34.7	2.3	3.8	7.9	0.2	14.2	7.6	32.4	2.2	0	42.1	1.3	2.7	4.4	0.5	8.9	

Start Time	EL CAMINO REAL Southbound				E. 25TH AVE Westbound				EL CAMINO REAL Northbound				W. 25TH AVE Eastbound				Int. Total
	Right	Thru	Left	App. Total	Right	Thru	Left	App. Total	Right	Thru	Left	App. Total	Right	Thru	Left	App. Total	
Peak Hour Analysis From 04:00 PM to 05:45 PM - Peak 1 of 1																	
Peak Hour for Entire Intersection Begins at 05:00 PM																	
05:00 PM	25	325	34	384	27	38	95	160	80	351	24	455	13	24	59	96	1095
05:15 PM	30	326	38	394	31	54	95	180	80	433	21	534	11	30	52	93	1201
05:30 PM	39	317	21	377	28	38	85	151	79	396	29	504	16	33	56	105	1137
05:45 PM	23	313	33	369	23	53	99	175	74	321	21	416	11	32	47	90	1050
Total Volume	117	1281	126	1524	109	183	374	666	313	1501	95	1909	51	119	214	384	4483
% App. Total	7.7	84.1	8.3		16.4	27.5	56.2		16.4	78.6	5		13.3	31	55.7		
PHF	.750	.982	.829	.967	.879	.847	.944	.925	.978	.867	.819	.894	.797	.902	.907	.914	.933

Traffic Data Service

Campbell, CA
 (408) 377-2988
 tdsbay@cs.com

File Name : 55PM FINAL
 Site Code : 00000055
 Start Date : 6/4/2013
 Page No : 2

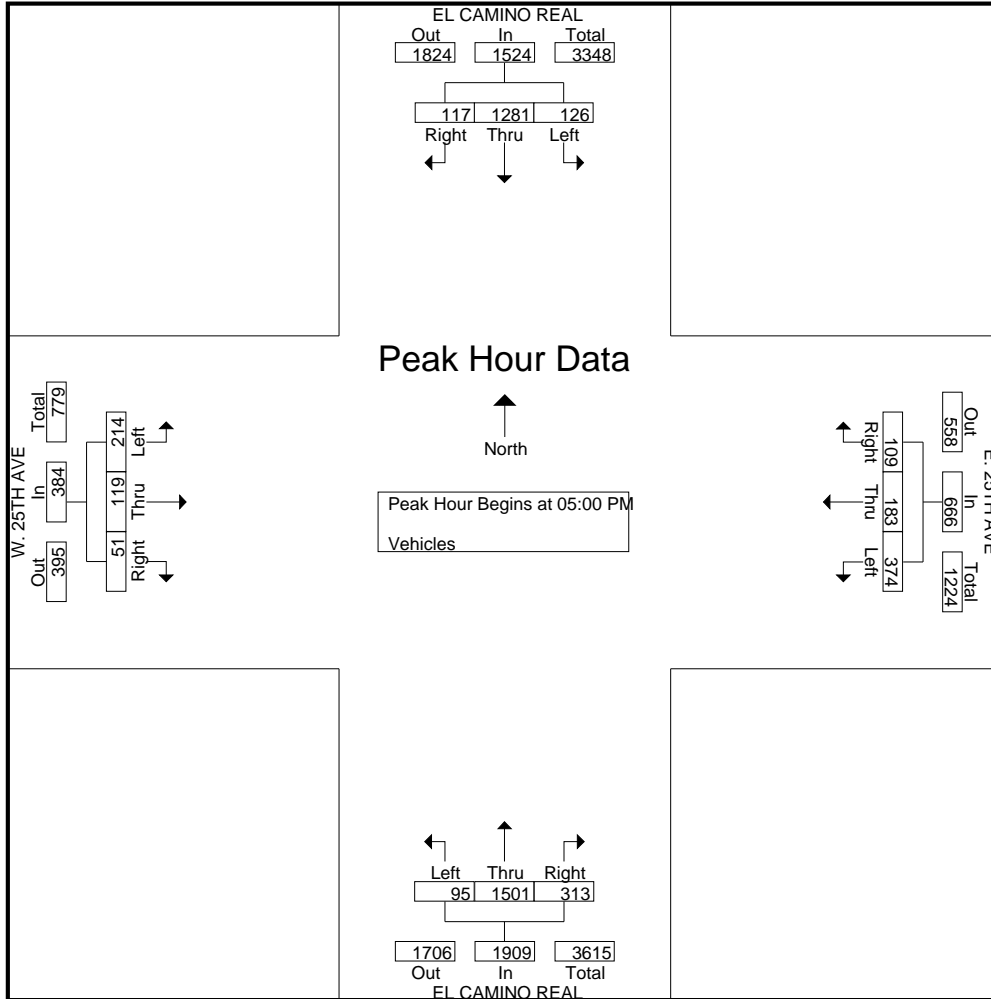

Traffic Data Service

Campbell, CA
 (408) 377-2988
 tdsbay@cs.com

File Name : 55PM FINAL
 Site Code : 00000055
 Start Date : 6/4/2013
 Page No : 1

Groups Printed- Bikes

Start Time	EL CAMINO REAL Southbound					E. 25TH AVE Westbound					EL CAMINO REAL Northbound					W. 25TH AVE Eastbound					Int. Total
	Right	Thru	Left	Peds	App. Total	Right	Thru	Left	Peds	App. Total	Right	Thru	Left	Peds	App. Total	Right	Thru	Left	Peds	App. Total	
04:00 PM	0	0	0	0	0	0	0	0	0	0	0	0	0	0	0	0	0	0	0	0	0
04:15 PM	0	0	0	0	0	0	0	0	0	0	0	0	0	0	0	0	2	0	0	0	2
04:30 PM	0	0	0	0	0	0	0	0	0	0	0	0	0	0	0	0	2	0	0	0	2
04:45 PM	0	0	0	0	0	0	0	0	0	0	0	0	0	0	0	0	0	0	0	0	0
Total	0	0	0	0	0	0	0	0	0	0	0	0	0	0	0	0	4	0	0	0	4
05:00 PM	0	0	1	0	1	0	1	0	0	1	0	0	0	0	0	0	3	0	0	0	3
05:15 PM	0	0	0	0	0	0	0	0	0	0	0	2	0	0	2	0	0	0	0	0	0
05:30 PM	0	0	0	0	0	0	1	0	0	1	0	0	0	0	0	0	2	0	0	0	2
05:45 PM	0	2	0	0	2	0	1	0	0	1	2	0	0	0	2	0	0	0	0	0	0
Total	0	2	1	0	3	0	3	0	0	3	2	2	0	0	4	0	5	0	0	0	5
Grand Total	0	2	1	0	3	0	3	0	0	3	2	2	0	0	4	0	9	0	0	0	9
Apprch %	0	66.7	33.3	0		0	100	0	0		50	50	0	0		0	100	0	0		
Total %	0	10.5	5.3	0	15.8	0	15.8	0	0	15.8	10.5	10.5	0	0	21.1	0	47.4	0	0	47.4	

Start Time	EL CAMINO REAL Southbound				E. 25TH AVE Westbound				EL CAMINO REAL Northbound				W. 25TH AVE Eastbound				Int. Total
	Right	Thru	Left	App. Total	Right	Thru	Left	App. Total	Right	Thru	Left	App. Total	Right	Thru	Left	App. Total	
05:00 PM	0	0	1	1	0	1	0	1	0	0	0	0	0	3	0	3	
05:15 PM	0	0	0	0	0	0	0	0	0	2	0	2	0	0	0	0	
05:30 PM	0	0	0	0	0	1	0	1	0	0	0	0	0	2	0	2	
05:45 PM	0	2	0	2	0	1	0	1	2	0	0	2	0	0	0	0	
Total Volume	0	2	1	3	0	3	0	3	2	2	0	4	0	5	0	5	
% App. Total	0	66.7	33.3		0	100	0		50	50	0		0	100	0		
PHF	.000	.250	.250	.375	.000	.750	.000	.750	.250	.250	.000	.500	.000	.417	.000	.417	

Peak Hour Analysis From 04:00 PM to 05:45 PM - Peak 1 of 1

Peak Hour for Entire Intersection Begins at 05:00 PM

Traffic Data Service

Campbell, CA
(408) 377-2988
tdsbay@cs.com

File Name : 55PM FINAL
Site Code : 00000055
Start Date : 6/4/2013
Page No : 2

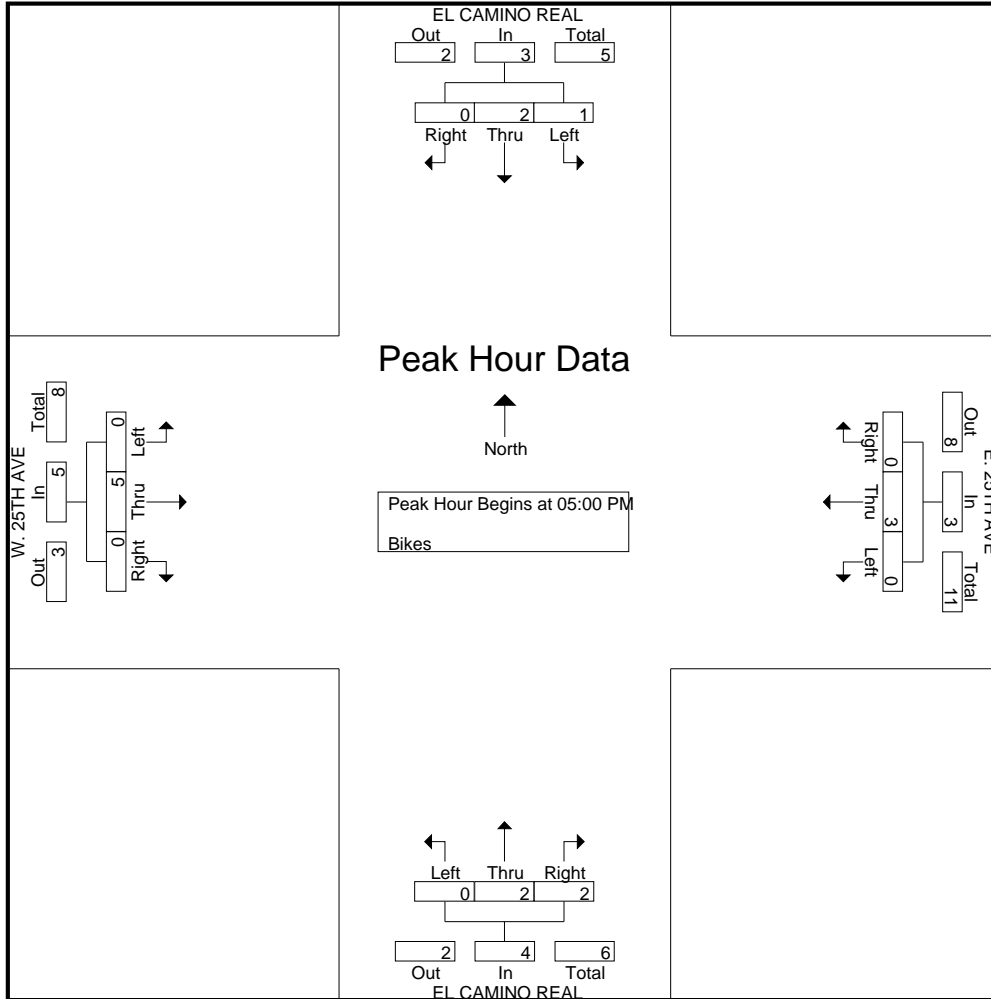

Traffic Data Service

Campbell, CA
 (408) 377-2988
 tdsbay@cs.com

File Name : 9AM FINAL
 Site Code : 00000009
 Start Date : 5/23/2013
 Page No : 1

Groups Printed- Vehicles

Start Time	EL CAMINO REAL Southbound					DRIVEWAY Westbound					EL CAMINO REAL Northbound					31ST AVE Eastbound					Int. Total
	Right	Thru	Left	Peds	App. Total	Right	Thru	Left	Peds	App. Total	Right	Thru	Left	Peds	App. Total	Right	Thru	Left	Peds	App. Total	
07:00 AM	13	127	10	2	152	3	11	8	2	24	38	128	2	6	174	15	9	15	1	40	390
07:15 AM	31	222	8	3	264	4	24	4	3	35	18	155	6	3	182	27	6	10	1	44	525
07:30 AM	34	255	12	9	310	15	38	13	5	71	14	240	8	4	266	74	19	27	1	121	768
07:45 AM	33	317	13	5	368	26	24	5	6	61	7	287	11	7	312	41	12	30	0	83	824
Total	111	921	43	19	1094	48	97	30	16	191	77	810	27	20	934	157	46	82	3	288	2507
08:00 AM	19	303	11	5	338	15	17	4	0	36	39	295	7	6	347	36	18	35	1	90	811
08:15 AM	31	303	19	3	356	6	10	2	0	18	28	311	12	10	361	47	4	23	3	77	812
08:30 AM	31	299	12	7	349	9	8	6	4	27	37	270	13	3	323	40	11	26	2	79	778
08:45 AM	35	294	9	5	343	3	6	3	0	12	17	265	8	9	299	23	3	17	0	43	697
Total	116	1199	51	20	1386	33	41	15	4	93	121	1141	40	28	1330	146	36	101	6	289	3098
Grand Total	227	2120	94	39	2480	81	138	45	20	284	198	1951	67	48	2264	303	82	183	9	577	5605
Apprch %	9.2	85.5	3.8	1.6		28.5	48.6	15.8	7		8.7	86.2	3	2.1		52.5	14.2	31.7	1.6		
Total %	4	37.8	1.7	0.7	44.2	1.4	2.5	0.8	0.4	5.1	3.5	34.8	1.2	0.9	40.4	5.4	1.5	3.3	0.2	10.3	

Start Time	EL CAMINO REAL Southbound				DRIVEWAY Westbound				EL CAMINO REAL Northbound				31ST AVE Eastbound				Int. Total
	Right	Thru	Left	App. Total	Right	Thru	Left	App. Total	Right	Thru	Left	App. Total	Right	Thru	Left	App. Total	
07:45 AM	33	317	13	363	26	24	5	55	7	287	11	305	41	12	30	83	806
08:00 AM	19	303	11	333	15	17	4	36	39	295	7	341	36	18	35	89	799
08:15 AM	31	303	19	353	6	10	2	18	28	311	12	351	47	4	23	74	796
08:30 AM	31	299	12	342	9	8	6	23	37	270	13	320	40	11	26	77	762
Total Volume	114	1222	55	1391	56	59	17	132	111	1163	43	1317	164	45	114	323	3163
% App. Total	8.2	87.9	4		42.4	44.7	12.9		8.4	88.3	3.3		50.8	13.9	35.3		
PHF	.864	.964	.724	.958	.538	.615	.708	.600	.712	.935	.827	.938	.872	.625	.814	.907	.981

Peak Hour Analysis From 07:00 AM to 08:45 AM - Peak 1 of 1

Peak Hour for Entire Intersection Begins at 07:45 AM

Traffic Data Service

Campbell, CA
(408) 377-2988
tdsbay@cs.com

File Name : 9AM FINAL
Site Code : 00000009
Start Date : 5/23/2013
Page No : 2

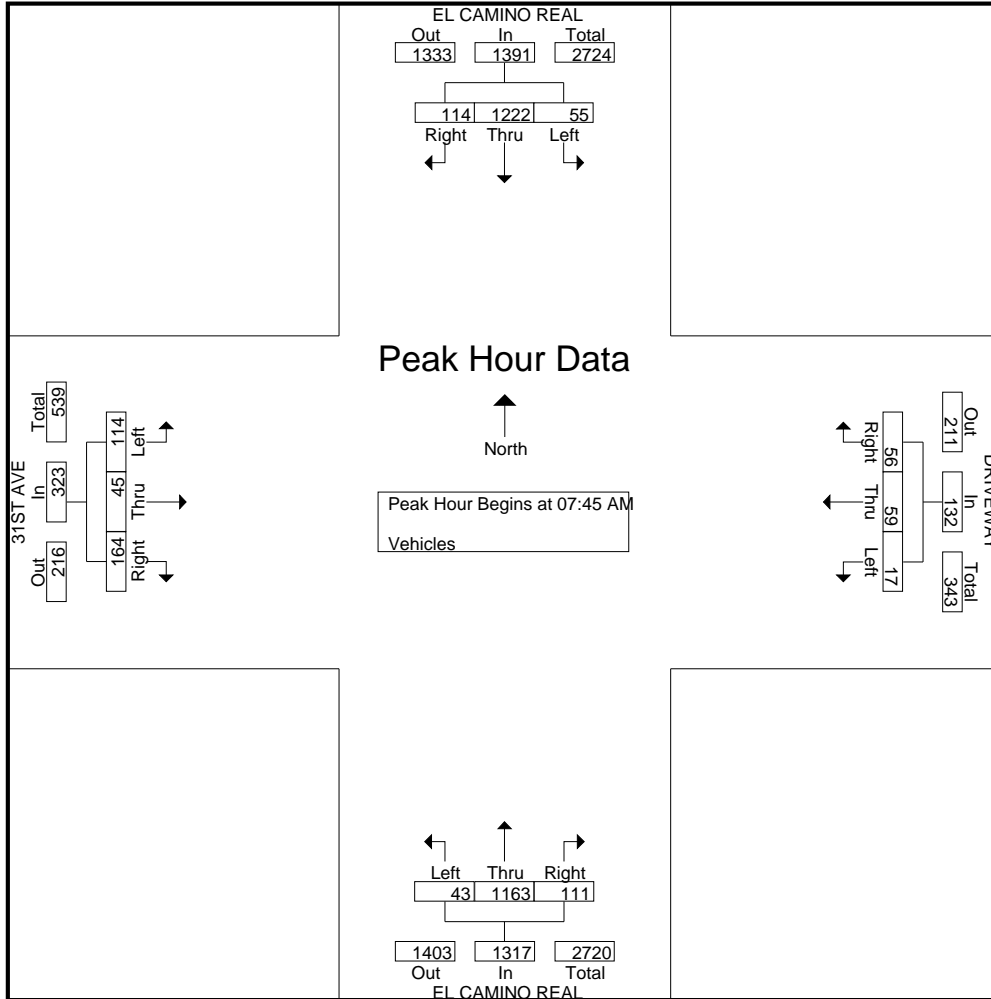

Traffic Data Service

Campbell, CA
 (408) 377-2988
 tdsbay@cs.com

File Name : 9AM FINAL
 Site Code : 00000009
 Start Date : 5/23/2013
 Page No : 1

Groups Printed- Bikes

Start Time	EL CAMINO REAL Southbound					DRIVEWAY Westbound					EL CAMINO REAL Northbound					31ST AVE Eastbound					Int. Total
	Right	Thru	Left	Peds	App. Total	Right	Thru	Left	Peds	App. Total	Right	Thru	Left	Peds	App. Total	Right	Thru	Left	Peds	App. Total	
07:00 AM	0	0	0	0	0	0	0	0	0	0	0	0	0	0	0	0	2	0	0	2	2
07:15 AM	2	0	0	0	2	0	1	0	0	1	0	0	0	0	0	2	4	0	0	6	9
07:30 AM	0	0	0	0	0	0	4	0	0	4	0	3	0	0	3	0	2	0	0	2	9
07:45 AM	0	1	0	0	1	0	1	0	0	1	0	1	0	0	1	0	1	0	0	1	4
Total	2	1	0	0	3	0	6	0	0	6	0	4	0	0	4	2	9	0	0	11	24
08:00 AM	0	0	0	0	0	0	0	1	0	1	1	0	0	0	1	0	1	0	0	1	3
08:15 AM	0	0	0	0	0	0	1	0	0	1	0	1	0	0	1	0	0	0	0	0	2
08:30 AM	0	0	0	0	0	0	0	0	0	0	0	2	0	0	2	0	1	0	0	1	3
08:45 AM	0	0	0	0	0	0	3	0	0	3	0	0	0	0	0	1	1	0	0	2	5
Total	0	0	0	0	0	0	4	1	0	5	1	3	0	0	4	1	3	0	0	4	13
Grand Total	2	1	0	0	3	0	10	1	0	11	1	7	0	0	8	3	12	0	0	15	37
Apprch %	66.7	33.3	0	0		0	90.9	9.1	0		12.5	87.5	0	0		20	80	0	0		
Total %	5.4	2.7	0	0	8.1	0	27	2.7	0	29.7	2.7	18.9	0	0	21.6	8.1	32.4	0	0	40.5	

Start Time	EL CAMINO REAL Southbound					DRIVEWAY Westbound					EL CAMINO REAL Northbound					31ST AVE Eastbound					Int. Total
	Right	Thru	Left	Peds	App. Total	Right	Thru	Left	Peds	App. Total	Right	Thru	Left	Peds	App. Total	Right	Thru	Left	Peds	App. Total	
07:15 AM	2	0	0	0	2	0	1	0	0	1	0	0	0	0	0	2	4	0	0	6	9
07:30 AM	0	0	0	0	0	0	4	0	0	4	0	3	0	0	3	0	2	0	0	2	9
07:45 AM	0	1	0	0	1	0	1	0	0	1	0	1	0	0	1	0	1	0	0	1	4
08:00 AM	0	0	0	0	0	0	0	0	1	1	1	0	0	0	1	0	1	0	0	1	3
Total Volume	2	1	0	0	3	0	6	1	0	7	1	4	0	0	5	2	8	0	0	10	25
% App. Total	66.7	33.3	0	0		0	85.7	14.3	0		20	80	0	0		20	80	0	0		
PHF	.250	.250	.000	.000	.375	.000	.375	.250	.438		.250	.333	.000	.417		.250	.500	.000	.417		.694

Peak Hour Analysis From 07:00 AM to 08:45 AM - Peak 1 of 1

Peak Hour for Entire Intersection Begins at 07:15 AM

Traffic Data Service

Campbell, CA
 (408) 377-2988
 tdsbay@cs.com

File Name : 9AM FINAL
 Site Code : 00000009
 Start Date : 5/23/2013
 Page No : 2

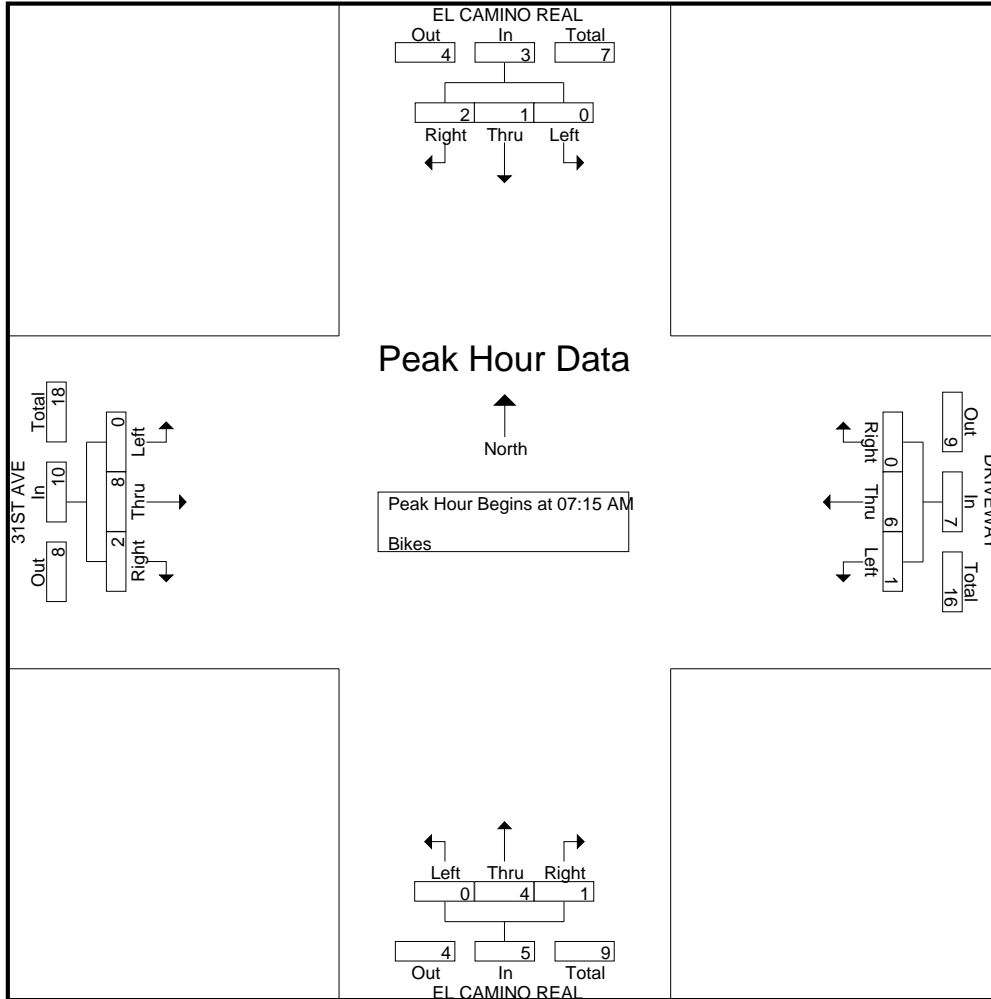

Traffic Data Service

Campbell, CA
 (408) 377-2988
 tdsbay@cs.com

File Name : 3PM FINAL
 Site Code : 00000003
 Start Date : 4/25/2013
 Page No : 1

Groups Printed- Vehicles

Start Time	EL CAMINO REAL Southbound					DVWY Westbound					EL CAMINO REAL Northbound					31ST AVE Eastbound					Int. Total
	Right	Thru	Left	Peds	App. Total	Right	Thru	Left	Peds	App. Total	Right	Thru	Left	Peds	App. Total	Right	Thru	Left	Peds	App. Total	
04:00 PM	60	281	15	5	361	6	19	4	1	30	2	295	31	8	336	32	2	47	0	81	808
04:15 PM	51	291	20	1	363	2	13	2	4	21	2	301	31	11	345	31	2	57	2	92	821
04:30 PM	44	279	16	1	340	5	29	14	0	48	2	347	43	6	398	32	0	54	10	96	882
04:45 PM	58	273	14	3	348	3	18	8	1	30	2	344	36	4	386	48	0	63	1	112	876
Total	213	1124	65	10	1412	16	79	28	6	129	8	1287	141	29	1465	143	4	221	13	381	3387
05:00 PM	73	311	15	4	403	5	4	11	0	20	4	344	24	7	379	47	11	66	4	128	930
05:15 PM	39	324	13	7	383	5	18	25	2	50	0	342	35	8	385	28	5	63	0	96	914
05:30 PM	57	331	16	3	407	0	4	24	2	30	0	334	38	6	378	33	9	58	2	102	917
05:45 PM	71	352	19	1	443	3	1	14	0	18	2	346	36	5	389	43	1	66	0	110	960
Total	240	1318	63	15	1636	13	27	74	4	118	6	1366	133	26	1531	151	26	253	6	436	3721
Grand Total	453	2442	128	25	3048	29	106	102	10	247	14	2653	274	55	2996	294	30	474	19	817	7108
Apprch %	14.9	80.1	4.2	0.8		11.7	42.9	41.3	4		0.5	88.6	9.1	1.8		36	3.7	58	2.3		
Total %	6.4	34.4	1.8	0.4	42.9	0.4	1.5	1.4	0.1	3.5	0.2	37.3	3.9	0.8	42.1	4.1	0.4	6.7	0.3	11.5	

Start Time	EL CAMINO REAL Southbound				DVWY Westbound				EL CAMINO REAL Northbound				31ST AVE Eastbound				Int. Total
	Right	Thru	Left	App. Total	Right	Thru	Left	App. Total	Right	Thru	Left	App. Total	Right	Thru	Left	App. Total	
Peak Hour Analysis From 04:00 PM to 05:45 PM - Peak 1 of 1																	
Peak Hour for Entire Intersection Begins at 05:00 PM																	
05:00 PM	73	311	15	399	5	4	11	20	4	344	24	372	47	11	66	124	915
05:15 PM	39	324	13	376	5	18	25	48	0	342	35	377	28	5	63	96	897
05:30 PM	57	331	16	404	0	4	24	28	0	334	38	372	33	9	58	100	904
05:45 PM	71	352	19	442	3	1	14	18	2	346	36	384	43	1	66	110	954
Total Volume	240	1318	63	1621	13	27	74	114	6	1366	133	1505	151	26	253	430	3670
% App. Total	14.8	81.3	3.9		11.4	23.7	64.9		0.4	90.8	8.8		35.1	6	58.8		
PHF	.822	.936	.829	.917	.650	.375	.740	.594	.375	.987	.875	.980	.803	.591	.958	.867	.962

Traffic Data Service

Campbell, CA
 (408) 377-2988
 tdsbay@cs.com

File Name : 3PM FINAL
 Site Code : 00000003
 Start Date : 4/25/2013
 Page No : 2

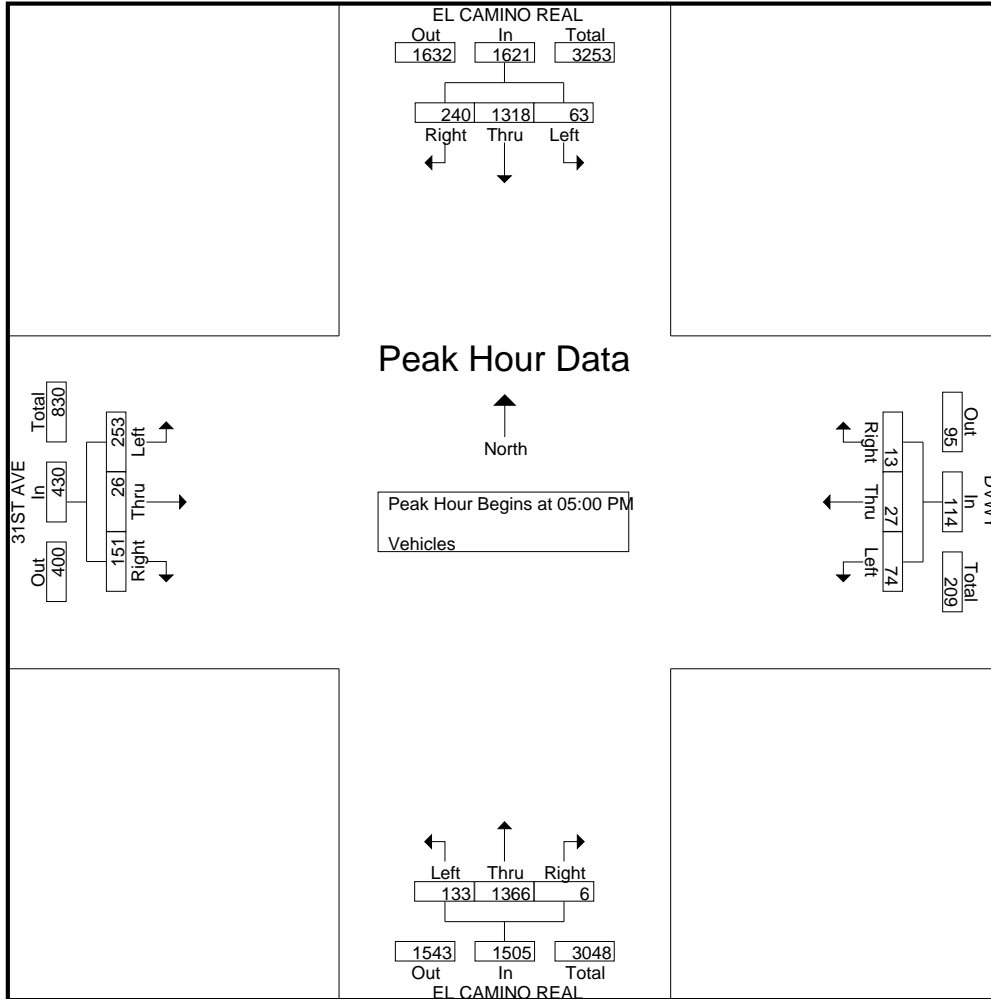

Traffic Data Service

Campbell, CA
 (408) 377-2988
 tdsbay@cs.com

File Name : 10AM FINAL
 Site Code : 00000010
 Start Date : 5/23/2013
 Page No : 1

Groups Printed- Vehicles

Start Time	EL CAMINO REAL Southbound					E. HILLSDALE BLVD Westbound					EL CAMINO REAL Northbound					W. HILLSDALE BLVD Eastbound					Int. Total
	Right	Thru	Left	Peds	App. Total	Right	Thru	Left	Peds	App. Total	Right	Thru	Left	Peds	App. Total	Right	Thru	Left	Peds	App. Total	
07:00 AM	4	102	36	17	159	38	89	43	0	170	69	99	5	5	178	8	49	17	2	76	583
07:15 AM	2	184	32	8	226	81	139	48	0	268	65	129	5	4	203	7	46	8	6	67	764
07:30 AM	14	222	95	15	346	121	181	63	0	365	84	224	6	5	319	7	104	15	1	127	1157
07:45 AM	15	259	88	20	382	136	194	70	0	400	86	236	8	11	341	11	97	10	5	123	1246
Total	35	767	251	60	1113	376	603	224	0	1203	304	688	24	25	1041	33	296	50	14	393	3750
08:00 AM	20	236	81	19	356	109	173	61	0	343	87	217	11	6	321	15	116	17	5	153	1173
08:15 AM	7	267	76	21	371	100	167	59	0	326	104	219	8	7	338	13	119	21	2	155	1190
08:30 AM	15	251	87	17	370	98	153	57	0	308	78	211	7	8	304	21	109	17	5	152	1134
08:45 AM	16	237	48	28	329	69	150	55	0	274	100	205	18	5	328	24	76	8	3	111	1042
Total	58	991	292	85	1426	376	643	232	0	1251	369	852	44	26	1291	73	420	63	15	571	4539
Grand Total	93	1758	543	145	2539	752	1246	456	0	2454	673	1540	68	51	2332	106	716	113	29	964	8289
Apprch %	3.7	69.2	21.4	5.7		30.6	50.8	18.6	0		28.9	66	2.9	2.2		11	74.3	11.7	3		
Total %	1.1	21.2	6.6	1.7	30.6	9.1	15	5.5	0	29.6	8.1	18.6	0.8	0.6	28.1	1.3	8.6	1.4	0.3	11.6	

Start Time	EL CAMINO REAL Southbound				E. HILLSDALE BLVD Westbound				EL CAMINO REAL Northbound				W. HILLSDALE BLVD Eastbound				Int. Total
	Right	Thru	Left	App. Total	Right	Thru	Left	App. Total	Right	Thru	Left	App. Total	Right	Thru	Left	App. Total	
Peak Hour Analysis From 07:00 AM to 08:45 AM - Peak 1 of 1																	
Peak Hour for Entire Intersection Begins at 07:30 AM																	
07:30 AM	14	222	95	331	121	181	63	365	84	224	6	314	7	104	15	126	1136
07:45 AM	15	259	88	362	136	194	70	400	86	236	8	330	11	97	10	118	1210
08:00 AM	20	236	81	337	109	173	61	343	87	217	11	315	15	116	17	148	1143
08:15 AM	7	267	76	350	100	167	59	326	104	219	8	331	13	119	21	153	1160
Total Volume	56	984	340	1380	466	715	253	1434	361	896	33	1290	46	436	63	545	4649
% App. Total	4.1	71.3	24.6		32.5	49.9	17.6		28	69.5	2.6		8.4	80	11.6		
PHF	.700	.921	.895	.953	.857	.921	.904	.896	.868	.949	.750	.974	.767	.916	.750	.891	.961

Traffic Data Service

Campbell, CA
 (408) 377-2988
 tdsbay@cs.com

File Name : 10AM FINAL
 Site Code : 00000010
 Start Date : 5/23/2013
 Page No : 2

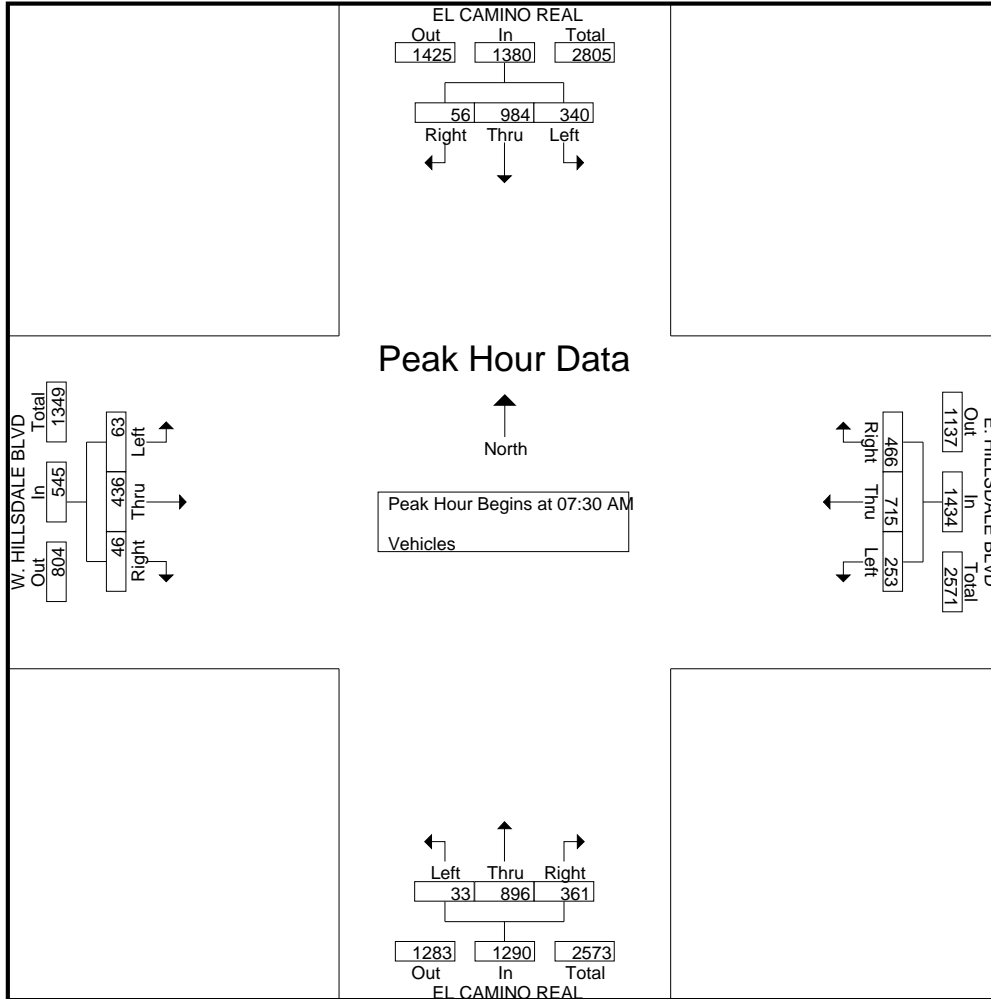

Traffic Data Service

Campbell, CA
 (408) 377-2988
 tdsbay@cs.com

File Name : 10AM FINAL
 Site Code : 00000010
 Start Date : 5/23/2013
 Page No : 1

Groups Printed- Vehicles

Start Time	EL CAMINO REAL Southbound					E. HILLSDALE BLVD Westbound					EL CAMINO REAL Northbound					W. HILLSDALE BLVD Eastbound					Int. Total
	Right	Thru	Left	Peds	App. Total	Right	Thru	Left	Peds	App. Total	Right	Thru	Left	Peds	App. Total	Right	Thru	Left	Peds	App. Total	
07:00 AM	4	102	36	17	159	38	89	43	0	170	69	99	5	5	178	8	49	17	2	76	583
07:15 AM	2	184	32	8	226	81	139	48	0	268	65	129	5	4	203	7	46	8	6	67	764
07:30 AM	14	222	95	15	346	121	181	63	0	365	84	224	6	5	319	7	104	15	1	127	1157
07:45 AM	15	259	88	20	382	136	194	70	0	400	86	236	8	11	341	11	97	10	5	123	1246
Total	35	767	251	60	1113	376	603	224	0	1203	304	688	24	25	1041	33	296	50	14	393	3750
08:00 AM	20	236	81	19	356	109	173	61	0	343	87	217	11	6	321	15	116	17	5	153	1173
08:15 AM	7	267	76	21	371	100	167	59	0	326	104	219	8	7	338	13	119	21	2	155	1190
08:30 AM	15	251	87	17	370	98	153	57	0	308	78	211	7	8	304	21	109	17	5	152	1134
08:45 AM	16	237	48	28	329	69	150	55	0	274	100	205	18	5	328	24	76	8	3	111	1042
Total	58	991	292	85	1426	376	643	232	0	1251	369	852	44	26	1291	73	420	63	15	571	4539
Grand Total	93	1758	543	145	2539	752	1246	456	0	2454	673	1540	68	51	2332	106	716	113	29	964	8289
Apprch %	3.7	69.2	21.4	5.7		30.6	50.8	18.6	0		28.9	66	2.9	2.2		11	74.3	11.7	3		
Total %	1.1	21.2	6.6	1.7	30.6	9.1	15	5.5	0	29.6	8.1	18.6	0.8	0.6	28.1	1.3	8.6	1.4	0.3	11.6	

Start Time	EL CAMINO REAL Southbound				E. HILLSDALE BLVD Westbound				EL CAMINO REAL Northbound				W. HILLSDALE BLVD Eastbound				Int. Total
	Right	Thru	Left	App. Total	Right	Thru	Left	App. Total	Right	Thru	Left	App. Total	Right	Thru	Left	App. Total	
Peak Hour Analysis From 07:00 AM to 08:45 AM - Peak 1 of 1																	
Peak Hour for Entire Intersection Begins at 07:30 AM																	
07:30 AM	14	222	95	331	121	181	63	365	84	224	6	314	7	104	15	126	1136
07:45 AM	15	259	88	362	136	194	70	400	86	236	8	330	11	97	10	118	1210
08:00 AM	20	236	81	337	109	173	61	343	87	217	11	315	15	116	17	148	1143
08:15 AM	7	267	76	350	100	167	59	326	104	219	8	331	13	119	21	153	1160
Total Volume	56	984	340	1380	466	715	253	1434	361	896	33	1290	46	436	63	545	4649
% App. Total	4.1	71.3	24.6		32.5	49.9	17.6		28	69.5	2.6		8.4	80	11.6		
PHF	.700	.921	.895	.953	.857	.921	.904	.896	.868	.949	.750	.974	.767	.916	.750	.891	.961

Traffic Data Service

Campbell, CA
 (408) 377-2988
 tdsbay@cs.com

File Name : 10AM FINAL
 Site Code : 00000010
 Start Date : 5/23/2013
 Page No : 2

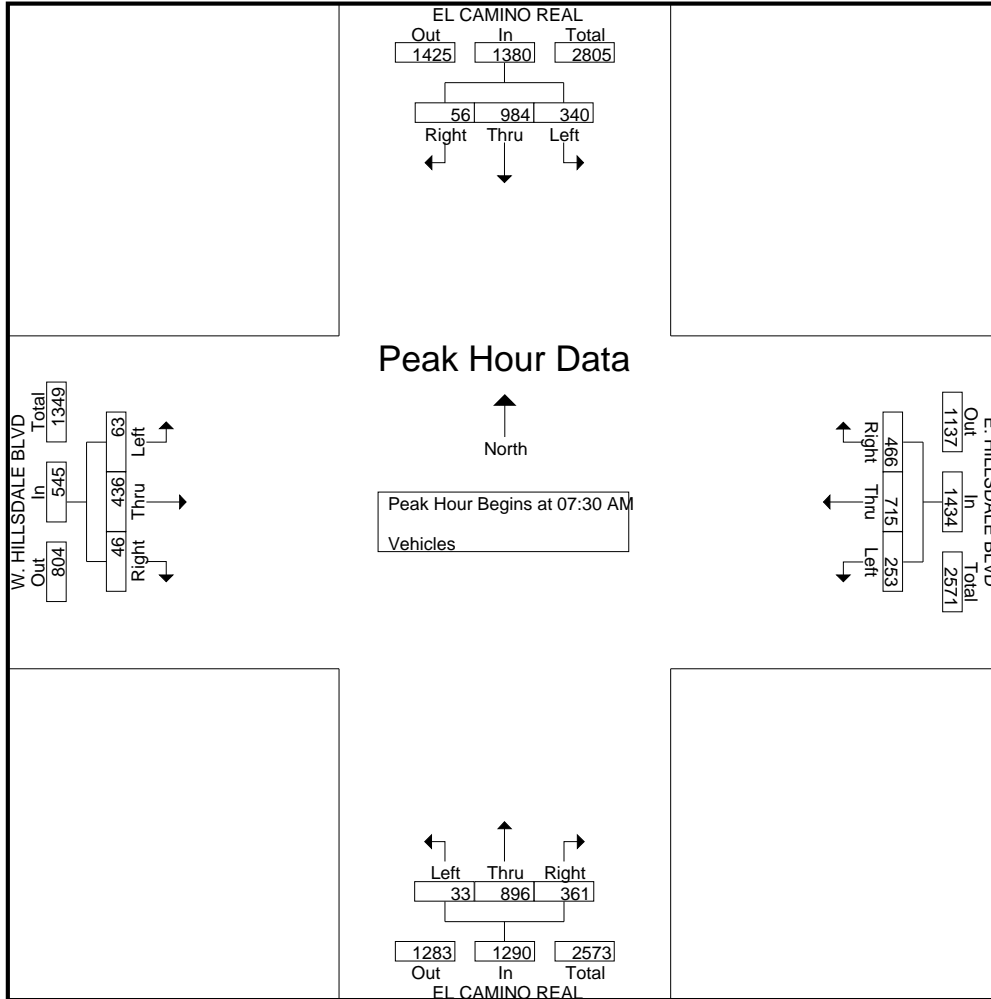

Traffic Data Service

Campbell, CA
 (408) 377-2988
 tdsbay@cs.com

File Name : 4PM FINAL
 Site Code : 00000004
 Start Date : 5/2/2013
 Page No : 1

Groups Printed- Vehicles

Start Time	EL CAMINO REAL Southbound					E. HILLSDALE BLVD Westbound					EL CAMINO REAL Northbound					W. HILLSDALE BLVD Eastbound					Int. Total
	Right	Thru	Left	Peds	App. Total	Right	Thru	Left	Peds	App. Total	Right	Thru	Left	Peds	App. Total	Right	Thru	Left	Peds	App. Total	
04:00 PM	37	179	79	11	306	79	176	85	0	340	82	225	34	8	349	35	126	32	4	197	1192
04:15 PM	13	193	89	15	310	80	178	77	0	335	79	260	31	6	376	35	143	27	16	221	1242
04:30 PM	36	201	96	20	353	70	193	65	0	328	87	244	26	5	362	25	114	28	4	171	1214
04:45 PM	27	219	71	19	336	99	173	85	0	357	72	268	34	8	382	32	147	35	8	222	1297
Total	113	792	335	65	1305	328	720	312	0	1360	320	997	125	27	1469	127	530	122	32	811	4945
05:00 PM	22	244	96	11	373	105	210	73	0	388	103	307	36	10	456	37	122	22	2	183	1400
05:15 PM	25	232	96	15	368	96	176	79	0	351	81	278	39	15	413	38	153	31	5	227	1359
05:30 PM	27	263	104	27	421	87	223	77	0	387	91	267	43	10	411	28	137	34	12	211	1430
05:45 PM	29	239	94	21	383	105	226	91	0	422	73	273	43	17	406	22	141	34	5	202	1413
Total	103	978	390	74	1545	393	835	320	0	1548	348	1125	161	52	1686	125	553	121	24	823	5602
Grand Total	216	1770	725	139	2850	721	1555	632	0	2908	668	2122	286	79	3155	252	1083	243	56	1634	10547
Apprch %	7.6	62.1	25.4	4.9		24.8	53.5	21.7	0		21.2	67.3	9.1	2.5		15.4	66.3	14.9	3.4		
Total %	2	16.8	6.9	1.3	27	6.8	14.7	6	0	27.6	6.3	20.1	2.7	0.7	29.9	2.4	10.3	2.3	0.5	15.5	

Start Time	EL CAMINO REAL Southbound				E. HILLSDALE BLVD Westbound				EL CAMINO REAL Northbound				W. HILLSDALE BLVD Eastbound				Int. Total
	Right	Thru	Left	App. Total	Right	Thru	Left	App. Total	Right	Thru	Left	App. Total	Right	Thru	Left	App. Total	
Peak Hour Analysis From 04:00 PM to 05:45 PM - Peak 1 of 1																	
Peak Hour for Entire Intersection Begins at 05:00 PM																	
05:00 PM	22	244	96	362	105	210	73	388	103	307	36	446	37	122	22	181	1377
05:15 PM	25	232	96	353	96	176	79	351	81	278	39	398	38	153	31	222	1324
05:30 PM	27	263	104	394	87	223	77	387	91	267	43	401	28	137	34	199	1381
05:45 PM	29	239	94	362	105	226	91	422	73	273	43	389	22	141	34	197	1370
Total Volume	103	978	390	1471	393	835	320	1548	348	1125	161	1634	125	553	121	799	5452
% App. Total	7	66.5	26.5		25.4	53.9	20.7		21.3	68.8	9.9		15.6	69.2	15.1		
PHF	.888	.930	.938	.933	.936	.924	.879	.917	.845	.916	.936	.916	.822	.904	.890	.900	.987

Traffic Data Service

Campbell, CA
 (408) 377-2988
 tdsbay@cs.com

File Name : 4PM FINAL
 Site Code : 00000004
 Start Date : 5/2/2013
 Page No : 2

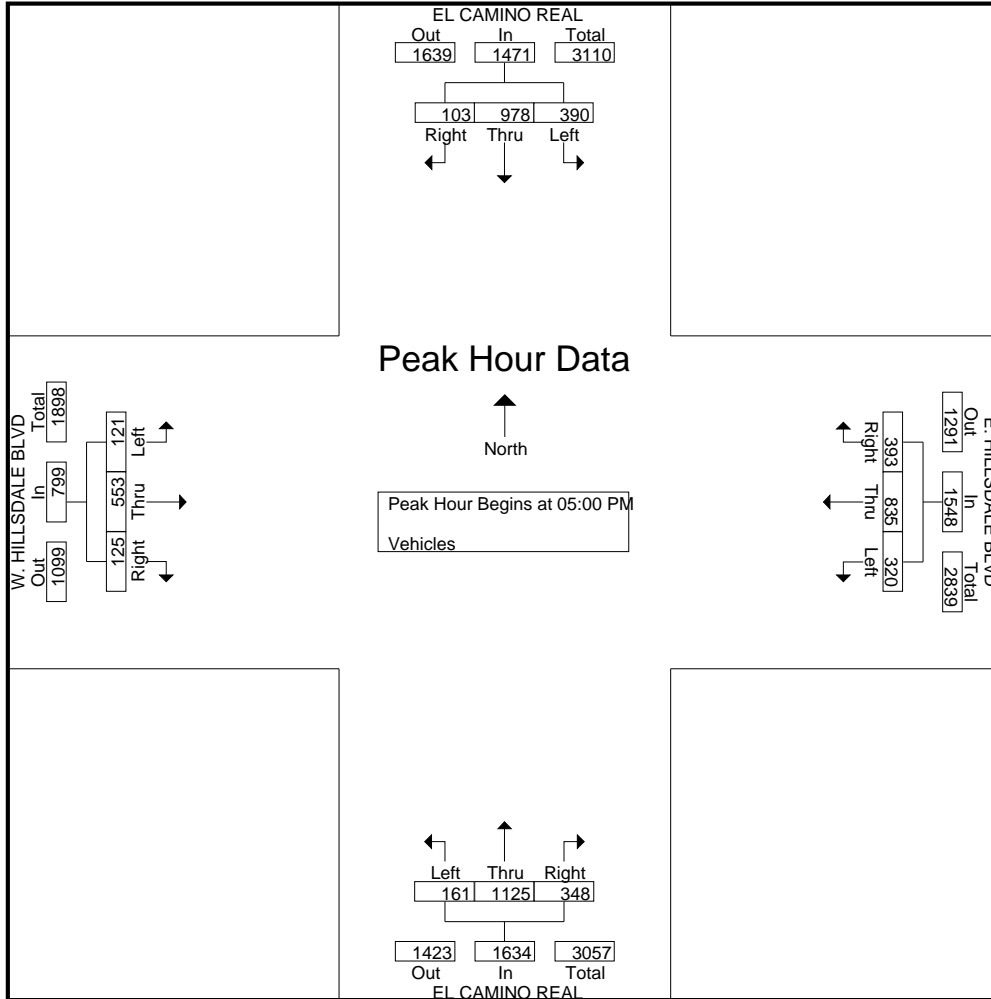

Traffic Data Service

Campbell, CA
 (408) 377-2988
 tdsbay@cs.com

File Name : 4PM FINAL
 Site Code : 00000004
 Start Date : 5/2/2013
 Page No : 1

Groups Printed- Bikes

Start Time	EL CAMINO REAL Southbound					E. HILLSDALE BLVD Westbound					EL CAMINO REAL Northbound					W. HILLSDALE BLVD Eastbound					Int. Total
	Right	Thru	Left	Peds	App. Total	Right	Thru	Left	Peds	App. Total	Right	Thru	Left	Peds	App. Total	Right	Thru	Left	Peds	App. Total	
04:00 PM	0	0	0	0	0	1	0	0	0	1	0	0	0	0	0	0	0	0	0	0	1
04:15 PM	0	0	0	0	0	0	0	0	0	0	0	0	0	0	0	0	0	0	0	0	0
04:30 PM	0	0	0	0	0	0	1	0	0	1	0	0	0	0	0	0	1	0	0	1	2
04:45 PM	0	1	0	0	1	0	0	0	0	0	0	0	0	0	0	0	0	0	0	0	1
Total	0	1	0	0	1	1	1	0	0	2	0	0	0	0	0	0	1	0	0	1	4
05:00 PM	2	0	0	0	2	0	0	0	0	0	0	0	0	0	0	0	0	0	0	0	2
05:15 PM	0	0	0	0	0	0	0	0	0	0	0	0	0	0	0	0	0	0	0	0	0
05:30 PM	0	1	0	0	1	0	0	0	0	0	0	0	1	0	1	0	0	0	0	0	2
05:45 PM	0	0	0	0	0	0	0	0	0	0	0	0	0	0	0	0	2	2	0	4	4
Total	2	1	0	0	3	0	0	0	0	0	0	0	1	0	1	0	2	2	0	4	8
Grand Total	2	2	0	0	4	1	1	0	0	2	0	0	1	0	1	0	3	2	0	5	12
Apprch %	50	50	0	0		50	50	0	0		0	0	100	0		0	60	40	0		
Total %	16.7	16.7	0	0	33.3	8.3	8.3	0	0	16.7	0	0	8.3	0	8.3	0	25	16.7	0	41.7	

Start Time	EL CAMINO REAL Southbound				E. HILLSDALE BLVD Westbound				EL CAMINO REAL Northbound				W. HILLSDALE BLVD Eastbound				Int. Total
	Right	Thru	Left	App. Total	Right	Thru	Left	App. Total	Right	Thru	Left	App. Total	Right	Thru	Left	App. Total	
Peak Hour Analysis From 04:00 PM to 05:45 PM - Peak 1 of 1																	
Peak Hour for Entire Intersection Begins at 05:00 PM																	
05:00 PM	2	0	0	2	0	0	0	0	0	0	0	0	0	0	0	0	2
05:15 PM	0	0	0	0	0	0	0	0	0	0	0	0	0	0	0	0	0
05:30 PM	0	1	0	1	0	0	0	0	0	0	1	1	0	0	0	0	2
05:45 PM	0	0	0	0	0	0	0	0	0	0	0	0	0	2	2	4	4
Total Volume	2	1	0	3	0	0	0	0	0	0	1	1	0	2	2	4	8
% App. Total	66.7	33.3	0		0	0	0		0	0	100		0	50	50		
PHF	.250	.250	.000	.375	.000	.000	.000	.000	.000	.000	.250	.250	.000	.250	.250	.250	.500

Traffic Data Service

Campbell, CA

(408) 377-2988

tdsbay@cs.com

File Name : 4PM FINAL

Site Code : 00000004

Start Date : 5/2/2013

Page No : 2

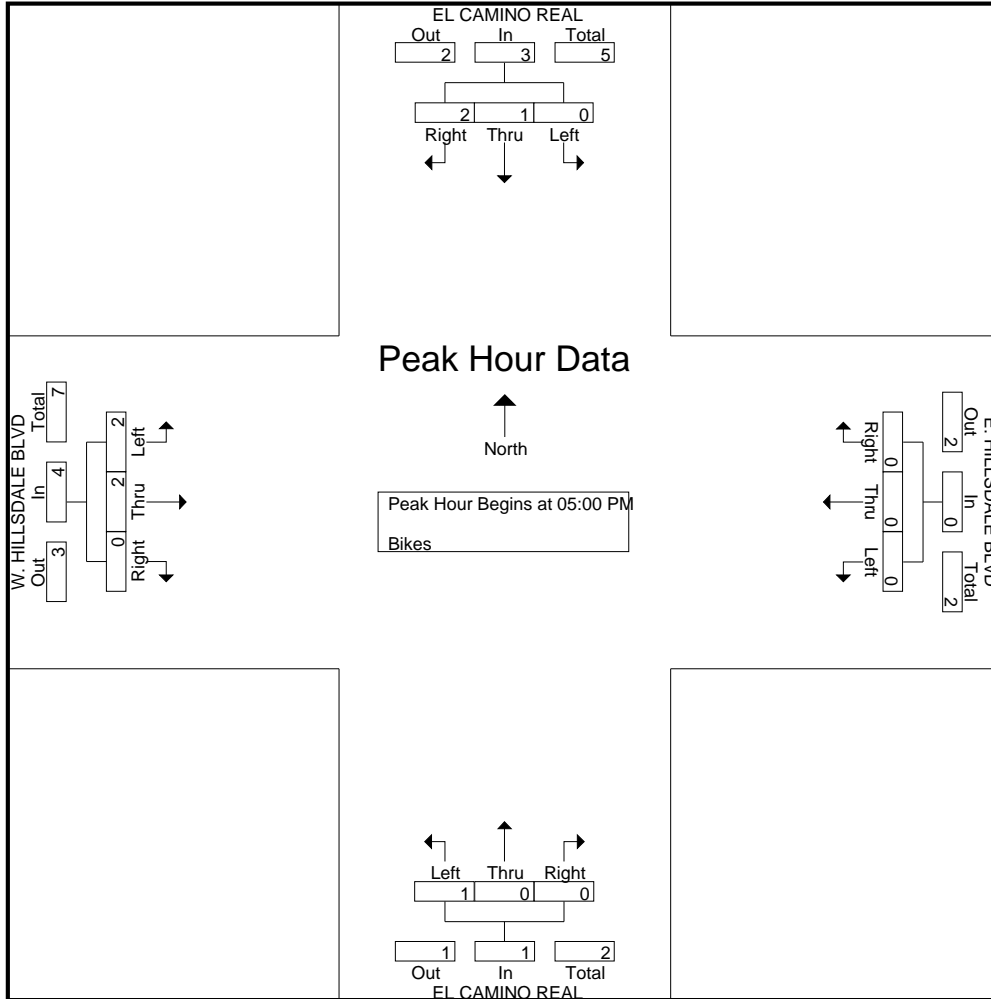

Traffic Data Service

Campbell, CA
 (408) 377-2988
 tdsbay@cs.com

File Name : 58AM FINAL
 Site Code : 00000058
 Start Date : 6/4/2013
 Page No : 1

Groups Printed- Vehicles

Start Time	CURTISS ST Southbound					E. HILLSDALE BLVD Westbound					CURTISS ST Northbound					E. HILLSDALE BLVD Eastbound					Int. Total
	Right	Thru	Left	Peds	App. Total	Right	Thru	Left	Peds	App. Total	Right	Thru	Left	Peds	App. Total	Right	Thru	Left	Peds	App. Total	
07:00 AM	2	0	9	5	16	3	137	4	5	149	12	1	7	1	21	1	170	1	0	172	358
07:15 AM	1	2	3	2	8	3	119	2	0	124	16	2	6	2	26	4	177	0	1	182	340
07:30 AM	2	1	8	3	14	6	116	1	1	124	26	0	17	2	45	9	218	2	11	240	423
07:45 AM	5	6	9	4	24	7	181	13	2	203	30	5	36	1	72	30	269	1	9	309	608
Total	10	9	29	14	62	19	553	20	8	600	84	8	66	6	164	44	834	4	21	903	1729
08:00 AM	6	0	12	2	20	4	213	1	4	222	53	1	21	1	76	15	281	2	0	298	616
08:15 AM	1	0	6	1	8	2	209	5	0	216	23	1	17	2	43	13	294	0	4	311	578
08:30 AM	6	1	3	4	14	8	205	3	1	217	17	1	15	5	38	8	302	3	1	314	583
08:45 AM	3	0	5	1	9	4	169	3	1	177	19	1	4	2	26	5	247	6	1	259	471
Total	16	1	26	8	51	18	796	12	6	832	112	4	57	10	183	41	1124	11	6	1182	2248
Grand Total	26	10	55	22	113	37	1349	32	14	1432	196	12	123	16	347	85	1958	15	27	2085	3977
Apprch %	23	8.8	48.7	19.5		2.6	94.2	2.2	1		56.5	3.5	35.4	4.6		4.1	93.9	0.7	1.3		
Total %	0.7	0.3	1.4	0.6	2.8	0.9	33.9	0.8	0.4	36	4.9	0.3	3.1	0.4	8.7	2.1	49.2	0.4	0.7	52.4	

Start Time	CURTISS ST Southbound				E. HILLSDALE BLVD Westbound				CURTISS ST Northbound				E. HILLSDALE BLVD Eastbound				Int. Total
	Right	Thru	Left	App. Total	Right	Thru	Left	App. Total	Right	Thru	Left	App. Total	Right	Thru	Left	App. Total	
07:45 AM	5	6	9	20	7	181	13	201	30	5	36	71	30	269	1	300	592
08:00 AM	6	0	12	18	4	213	1	218	53	1	21	75	15	281	2	298	609
08:15 AM	1	0	6	7	2	209	5	216	23	1	17	41	13	294	0	307	571
08:30 AM	6	1	3	10	8	205	3	216	17	1	15	33	8	302	3	313	572
Total Volume	18	7	30	55	21	808	22	851	123	8	89	220	66	1146	6	1218	2344
% App. Total	32.7	12.7	54.5		2.5	94.9	2.6		55.9	3.6	40.5		5.4	94.1	0.5		
PHF	.750	.292	.625	.688	.656	.948	.423	.976	.580	.400	.618	.733	.550	.949	.500	.973	.962

Peak Hour Analysis From 07:00 AM to 08:45 AM - Peak 1 of 1

Peak Hour for Entire Intersection Begins at 07:45 AM

Traffic Data Service

Campbell, CA
(408) 377-2988
tdsbay@cs.com

File Name : 58AM FINAL
Site Code : 00000058
Start Date : 6/4/2013
Page No : 2

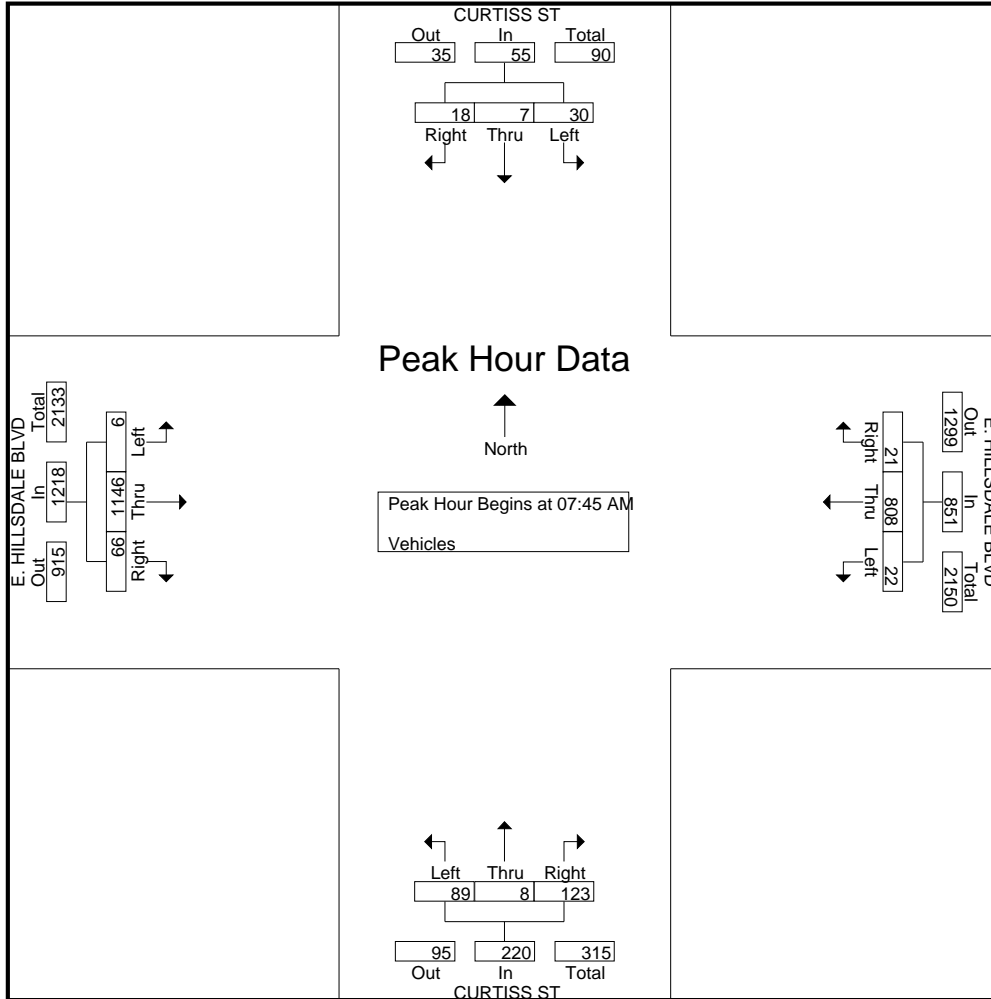

Traffic Data Service

Campbell, CA
 (408) 377-2988
 tdsbay@cs.com

File Name : 58PM FINAL
 Site Code : 00000058
 Start Date : 6/4/2013
 Page No : 1

Groups Printed- Vehicles

Start Time	CURTISS ST Southbound					E. HILLSDALE BLVD Westbound					CURTISS ST Northbound					E. HILLSDALE BLVD Eastbound					Int. Total
	Right	Thru	Left	Peds	App. Total	Right	Thru	Left	Peds	App. Total	Right	Thru	Left	Peds	App. Total	Right	Thru	Left	Peds	App. Total	
04:00 PM	4	0	5	9	18	6	227	1	0	234	9	3	7	5	24	12	274	0	1	287	563
04:15 PM	5	1	7	1	14	10	266	1	1	278	11	6	4	1	22	14	300	0	1	315	629
04:30 PM	4	1	4	4	13	7	273	1	0	281	17	5	9	5	36	16	285	0	0	301	631
04:45 PM	0	2	13	7	22	15	251	4	1	271	17	4	12	1	34	9	252	1	0	262	589
Total	13	4	29	21	67	38	1017	7	2	1064	54	18	32	12	116	51	1111	1	2	1165	2412
05:00 PM	1	2	8	12	23	8	285	2	1	296	15	4	7	2	28	11	338	0	0	349	696
05:15 PM	0	2	9	5	16	8	312	1	4	325	14	6	13	1	34	15	321	0	5	341	716
05:30 PM	3	1	5	5	14	7	325	1	5	338	18	4	13	2	37	10	308	0	3	321	710
05:45 PM	3	2	10	3	18	12	325	1	1	339	9	6	7	2	24	13	327	0	3	343	724
Total	7	7	32	25	71	35	1247	5	11	1298	56	20	40	7	123	49	1294	0	11	1354	2846
Grand Total	20	11	61	46	138	73	2264	12	13	2362	110	38	72	19	239	100	2405	1	13	2519	5258
Apprch %	14.5	8	44.2	33.3		3.1	95.9	0.5	0.6		46	15.9	30.1	7.9		4	95.5	0	0.5		
Total %	0.4	0.2	1.2	0.9	2.6	1.4	43.1	0.2	0.2	44.9	2.1	0.7	1.4	0.4	4.5	1.9	45.7	0	0.2	47.9	

Start Time	CURTISS ST Southbound				E. HILLSDALE BLVD Westbound				CURTISS ST Northbound				E. HILLSDALE BLVD Eastbound				Int. Total
	Right	Thru	Left	App. Total	Right	Thru	Left	App. Total	Right	Thru	Left	App. Total	Right	Thru	Left	App. Total	
Peak Hour Analysis From 04:00 PM to 05:45 PM - Peak 1 of 1																	
Peak Hour for Entire Intersection Begins at 05:00 PM																	
05:00 PM	1	2	8	11	8	285	2	295	15	4	7	26	11	338	0	349	681
05:15 PM	0	2	9	11	8	312	1	321	14	6	13	33	15	321	0	336	701
05:30 PM	3	1	5	9	7	325	1	333	18	4	13	35	10	308	0	318	695
05:45 PM	3	2	10	15	12	325	1	338	9	6	7	22	13	327	0	340	715
Total Volume	7	7	32	46	35	1247	5	1287	56	20	40	116	49	1294	0	1343	2792
% App. Total	15.2	15.2	69.6		2.7	96.9	0.4		48.3	17.2	34.5		3.6	96.4	0		
PHF	.583	.875	.800	.767	.729	.959	.625	.952	.778	.833	.769	.829	.817	.957	.000	.962	.976

Traffic Data Service

Campbell, CA
 (408) 377-2988
 tdsbay@cs.com

File Name : 58PM FINAL
 Site Code : 00000058
 Start Date : 6/4/2013
 Page No : 2

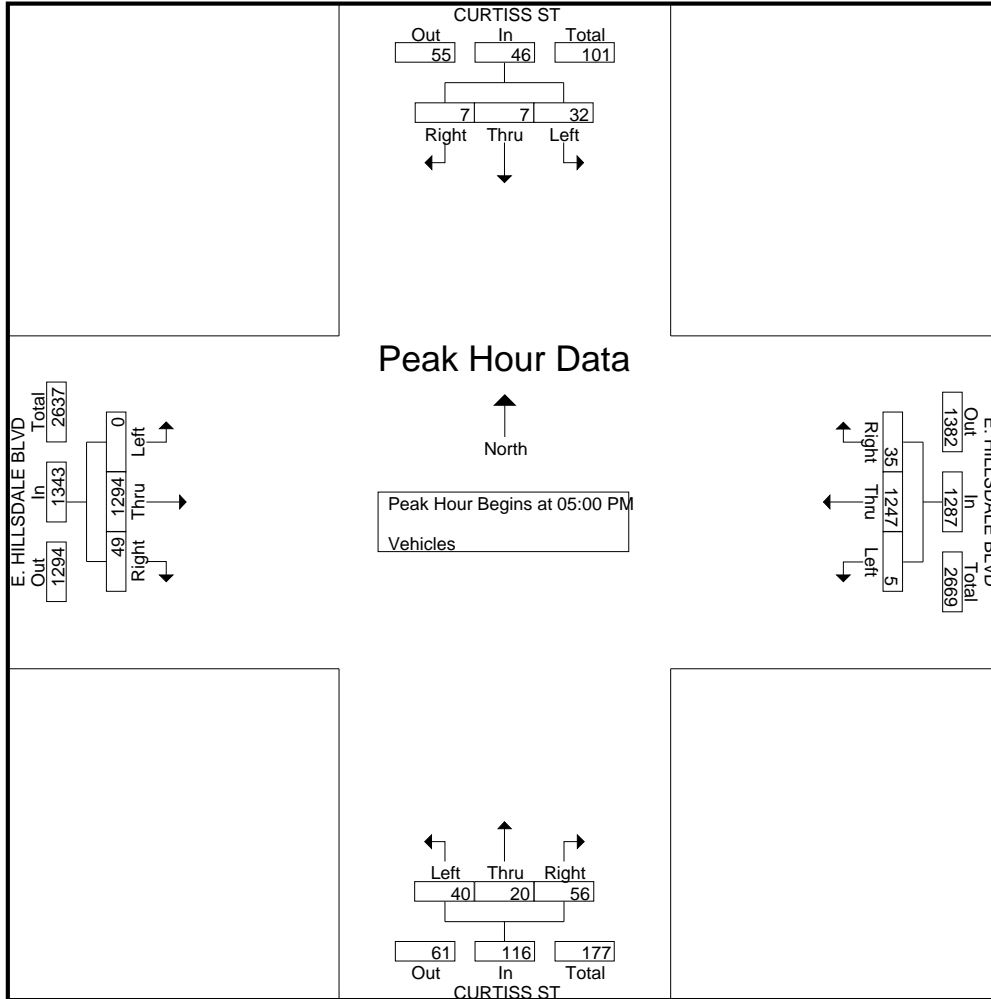

Traffic Data Service

Campbell, CA
 (408) 377-2988
 tdsbay@cs.com

File Name : 58PM FINAL
 Site Code : 00000058
 Start Date : 6/4/2013
 Page No : 1

Groups Printed- Bikes

Start Time	CURTISS ST Southbound					E. HILLSDALE BLVD Westbound					CURTISS ST Northbound					E. HILLSDALE BLVD Eastbound					Int. Total
	Right	Thru	Left	Peds	App. Total	Right	Thru	Left	Peds	App. Total	Right	Thru	Left	Peds	App. Total	Right	Thru	Left	Peds	App. Total	
04:00 PM	0	0	0	0	0	0	0	0	0	0	1	0	0	0	1	0	0	0	0	0	1
04:15 PM	0	1	0	0	1	0	1	0	0	1	0	0	0	0	0	0	2	0	0	0	2
04:30 PM	0	0	0	0	0	0	0	0	0	0	0	0	0	0	0	0	0	0	0	0	0
04:45 PM	0	0	0	0	0	0	0	0	0	0	0	0	0	0	0	0	1	0	0	0	1
Total	0	1	0	0	1	0	1	0	0	1	1	0	0	0	1	0	3	0	0	0	3
05:00 PM	0	0	0	0	0	0	2	0	0	2	0	0	0	0	0	0	0	0	0	0	0
05:15 PM	0	1	0	0	1	1	1	0	0	2	0	0	0	0	0	0	1	0	0	0	1
05:30 PM	0	0	0	0	0	0	0	0	0	0	0	0	0	0	0	0	1	0	0	0	1
05:45 PM	0	0	0	0	0	0	0	0	0	0	0	0	0	0	0	0	1	0	0	0	1
Total	0	1	0	0	1	1	3	0	0	4	0	0	0	0	0	0	3	0	0	0	3
Grand Total	0	2	0	0	2	1	4	0	0	5	1	0	0	0	1	0	6	0	0	0	6
Apprch %	0	100	0	0		20	80	0	0		100	0	0	0		0	100	0	0		
Total %	0	14.3	0	0	14.3	7.1	28.6	0	0	35.7	7.1	0	0	0	7.1	0	42.9	0	0	42.9	

Start Time	CURTISS ST Southbound				E. HILLSDALE BLVD Westbound				CURTISS ST Northbound				E. HILLSDALE BLVD Eastbound				Int. Total
	Right	Thru	Left	App. Total	Right	Thru	Left	App. Total	Right	Thru	Left	App. Total	Right	Thru	Left	App. Total	
04:45 PM	0	0	0	0	0	0	0	0	0	0	0	0	0	1	0	1	
05:00 PM	0	0	0	0	0	2	0	2	0	0	0	0	0	0	0	0	
05:15 PM	0	1	0	1	1	1	0	2	0	0	0	0	0	1	0	1	
05:30 PM	0	0	0	0	0	0	0	0	0	0	0	0	0	1	0	1	
Total Volume	0	1	0	1	1	3	0	4	0	0	0	0	0	3	0	3	
% App. Total	0	100	0		25	75	0		0	0	0		0	100	0		
PHF	.000	.250	.000	.250	.250	.375	.000	.500	.000	.000	.000	.000	.000	.750	.000	.750	

Peak Hour Analysis From 04:00 PM to 05:45 PM - Peak 1 of 1

Peak Hour for Entire Intersection Begins at 04:45 PM

Traffic Data Service

Campbell, CA
(408) 377-2988
tdsbay@cs.com

File Name : 58PM FINAL
Site Code : 00000058
Start Date : 6/4/2013
Page No : 2

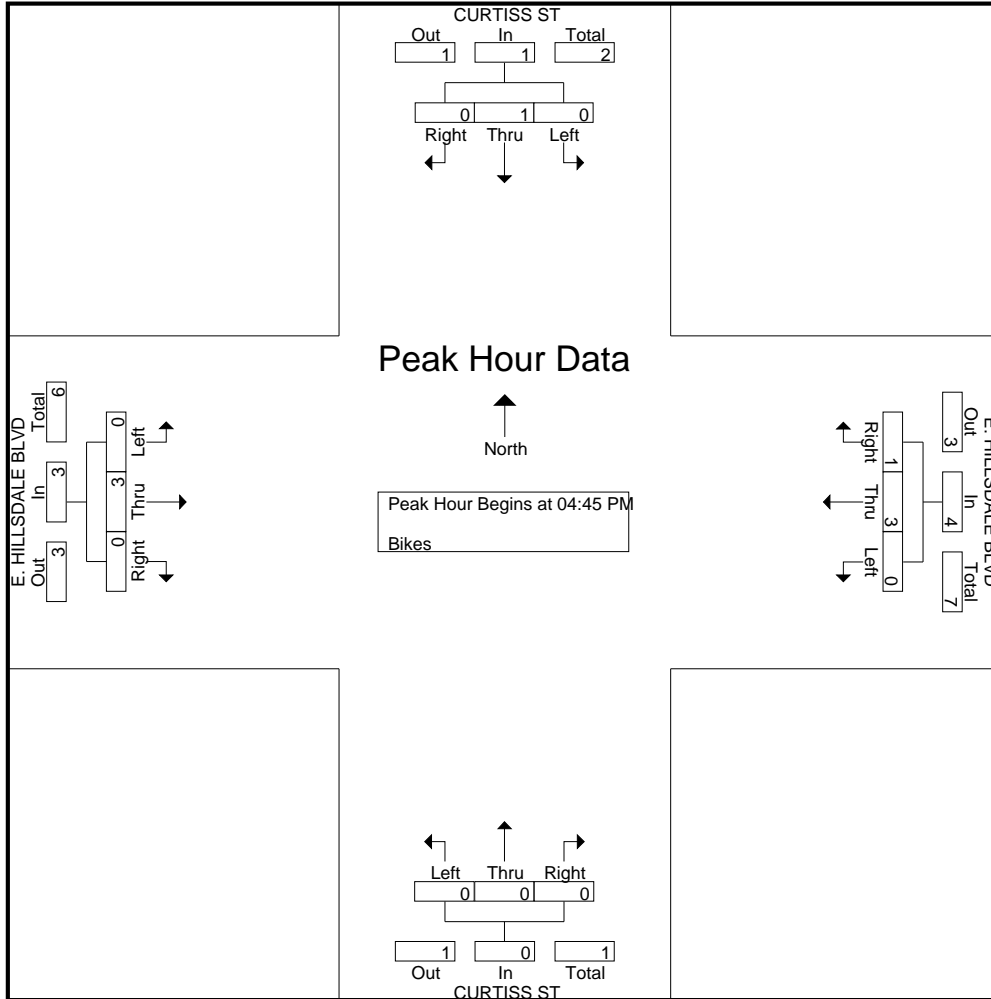

Traffic Data Service

Campbell, CA
 (408) 377-2988
 tdsbay@cs.com

File Name : 58AM FINAL
 Site Code : 00000058
 Start Date : 6/4/2013
 Page No : 1

Groups Printed- Bikes

Start Time	CURTISS ST Southbound					E. HILLSDALE BLVD Westbound					CURTISS ST Northbound					E. HILLSDALE BLVD Eastbound					Int. Total
	Right	Thru	Left	Peds	App. Total	Right	Thru	Left	Peds	App. Total	Right	Thru	Left	Peds	App. Total	Right	Thru	Left	Peds	App. Total	
07:00 AM	0	0	0	0	0	0	0	0	0	0	0	0	0	0	0	0	1	0	0	1	1
07:15 AM	0	0	0	0	0	0	0	0	0	0	0	0	0	0	0	0	0	0	0	0	0
07:30 AM	0	0	0	0	0	0	0	0	0	0	0	0	0	0	0	0	3	0	0	3	3
07:45 AM	0	0	0	0	0	0	0	0	0	0	0	0	0	0	0	0	1	0	0	1	1
Total	0	0	0	0	0	0	0	0	0	0	0	0	0	0	0	0	5	0	0	5	5
08:00 AM	0	0	0	0	0	0	0	0	0	0	1	0	0	0	1	0	0	0	0	0	1
08:15 AM	0	0	0	0	0	0	1	0	0	1	0	0	0	0	0	0	1	0	0	1	2
08:30 AM	0	0	0	0	0	0	0	0	0	0	0	1	0	0	1	0	0	0	0	0	1
08:45 AM	0	0	0	0	0	1	2	0	0	3	1	0	0	0	1	0	0	0	0	0	4
Total	0	0	0	0	0	1	3	0	0	4	2	1	0	0	3	0	1	0	0	1	8
Grand Total	0	0	0	0	0	1	3	0	0	4	2	1	0	0	3	0	6	0	0	6	13
Apprch %	0	0	0	0		25	75	0	0		66.7	33.3	0	0		0	100	0	0		
Total %	0	0	0	0		7.7	23.1	0	0	30.8	15.4	7.7	0	0	23.1	0	46.2	0	0	46.2	

Start Time	CURTISS ST Southbound				E. HILLSDALE BLVD Westbound				CURTISS ST Northbound				E. HILLSDALE BLVD Eastbound				Int. Total
	Right	Thru	Left	App. Total	Right	Thru	Left	App. Total	Right	Thru	Left	App. Total	Right	Thru	Left	App. Total	
08:00 AM	0	0	0	0	0	0	0	0	1	0	0	1	0	0	0	0	1
08:15 AM	0	0	0	0	0	1	0	1	0	0	0	0	0	1	0	1	2
08:30 AM	0	0	0	0	0	0	0	0	0	1	0	1	0	0	0	0	1
08:45 AM	0	0	0	0	1	2	0	3	1	0	0	1	0	0	0	0	4
Total Volume	0	0	0	0	1	3	0	4	2	1	0	3	0	1	0	1	8
% App. Total	0	0	0		25	75	0		66.7	33.3	0		0	100	0		
PHF	.000	.000	.000	.000	.250	.375	.000	.333	.500	.250	.000	.750	.000	.250	.000	.250	.500

Peak Hour Analysis From 07:00 AM to 08:45 AM - Peak 1 of 1

Peak Hour for Entire Intersection Begins at 08:00 AM

Traffic Data Service

Campbell, CA
(408) 377-2988
tdsbay@cs.com

File Name : 58AM FINAL
Site Code : 00000058
Start Date : 6/4/2013
Page No : 2

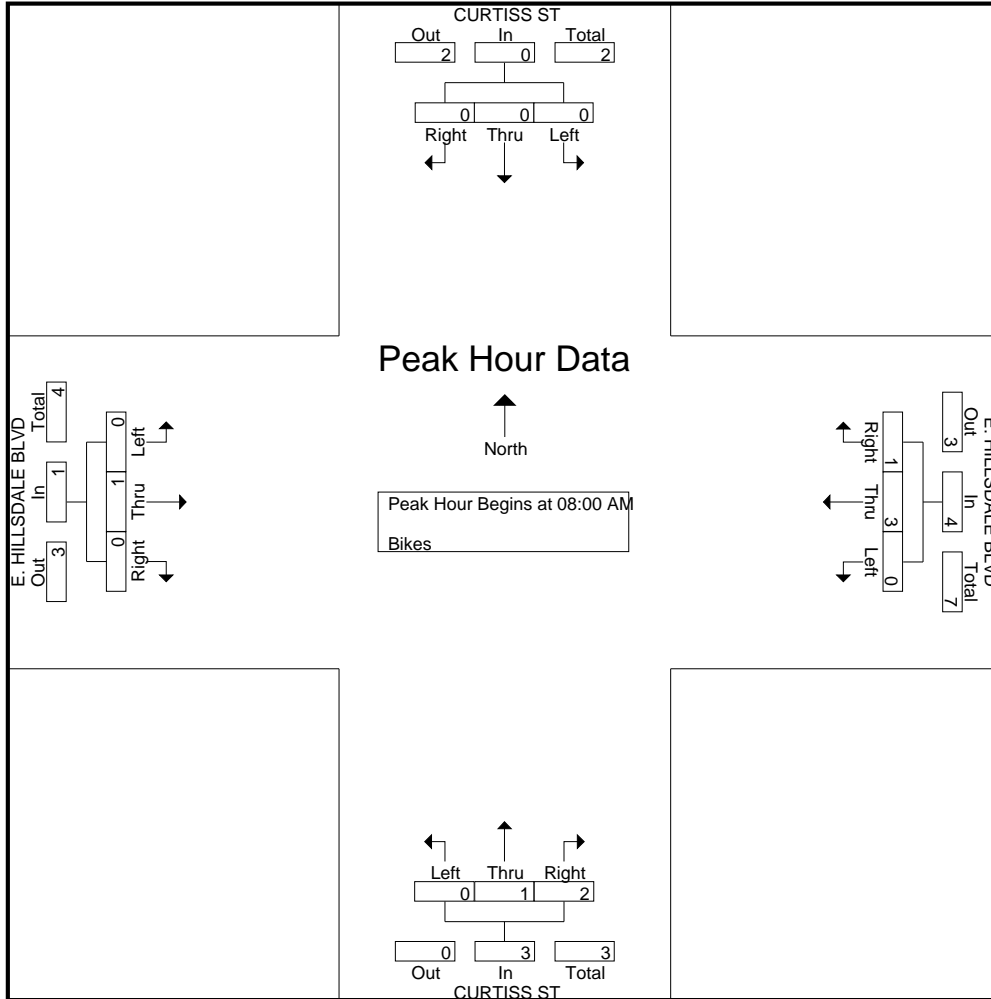

Traffic Data Service

Campbell, CA
 (408) 377-2988
 tdsbay@cs.com

File Name : 11PM FINAL
 Site Code : 00000011
 Start Date : 5/22/2013
 Page No : 1

Groups Printed- Vehicles

Start Time	EL CAMINO REAL Southbound					RALSTON AVE Westbound					EL CAMINO REAL Northbound					RALSTON AVE Eastbound					Int. Total
	Right	Thru	Left	Peds	App. Total	Right	Thru	Left	Peds	App. Total	Right	Thru	Left	Peds	App. Total	Right	Thru	Left	Peds	App. Total	
04:00 PM	23	163	43	9	238	89	152	51	0	292	44	164	26	2	236	16	143	50	7	216	982
04:15 PM	42	186	57	11	296	60	148	48	0	256	58	236	33	7	334	14	136	47	8	205	1091
04:30 PM	28	184	49	11	272	91	162	61	4	318	47	212	21	9	289	19	125	60	6	210	1089
04:45 PM	33	202	60	6	301	74	162	61	1	298	56	254	38	11	359	11	148	42	6	207	1165
Total	126	735	209	37	1107	314	624	221	5	1164	205	866	118	29	1218	60	552	199	27	838	4327
05:00 PM	21	209	50	11	291	74	180	70	0	324	41	221	31	11	304	20	143	59	9	231	1150
05:15 PM	33	229	61	11	334	88	154	62	4	308	56	246	29	13	344	11	132	57	8	208	1194
05:30 PM	28	200	56	17	301	91	178	65	2	336	54	224	19	9	306	22	140	53	7	222	1165
05:45 PM	43	250	62	24	379	99	156	62	1	318	49	263	19	10	341	25	127	54	5	211	1249
Total	125	888	229	63	1305	352	668	259	7	1286	200	954	98	43	1295	78	542	223	29	872	4758
Grand Total	251	1623	438	100	2412	666	1292	480	12	2450	405	1820	216	72	2513	138	1094	422	56	1710	9085
Apprch %	10.4	67.3	18.2	4.1		27.2	52.7	19.6	0.5		16.1	72.4	8.6	2.9		8.1	64	24.7	3.3		
Total %	2.8	17.9	4.8	1.1	26.5	7.3	14.2	5.3	0.1	27	4.5	20	2.4	0.8	27.7	1.5	12	4.6	0.6	18.8	

Start Time	EL CAMINO REAL Southbound				RALSTON AVE Westbound				EL CAMINO REAL Northbound				RALSTON AVE Eastbound				Int. Total
	Right	Thru	Left	App. Total	Right	Thru	Left	App. Total	Right	Thru	Left	App. Total	Right	Thru	Left	App. Total	
Peak Hour Analysis From 04:00 PM to 05:45 PM - Peak 1 of 1																	
Peak Hour for Entire Intersection Begins at 05:00 PM																	
05:00 PM	21	209	50	280	74	180	70	324	41	221	31	293	20	143	59	222	1119
05:15 PM	33	229	61	323	88	154	62	304	56	246	29	331	11	132	57	200	1158
05:30 PM	28	200	56	284	91	178	65	334	54	224	19	297	22	140	53	215	1130
05:45 PM	43	250	62	355	99	156	62	317	49	263	19	331	25	127	54	206	1209
Total Volume	125	888	229	1242	352	668	259	1279	200	954	98	1252	78	542	223	843	4616
% App. Total	10.1	71.5	18.4		27.5	52.2	20.3		16	76.2	7.8		9.3	64.3	26.5		
PHF	.727	.888	.923	.875	.889	.928	.925	.957	.893	.907	.790	.946	.780	.948	.945	.949	.955

Traffic Data Service

Campbell, CA
(408) 377-2988
tdsbay@cs.com

File Name : 11PM FINAL
Site Code : 00000011
Start Date : 5/22/2013
Page No : 2

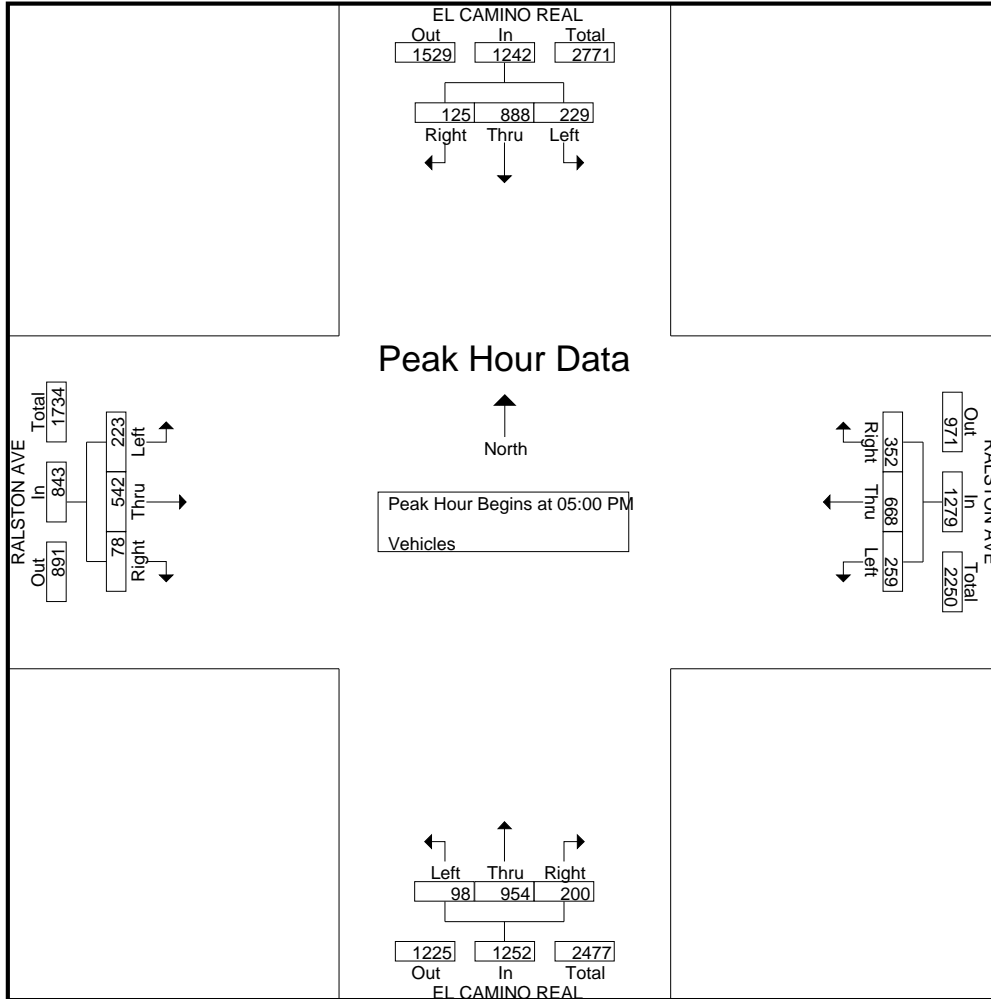

Traffic Data Service

Campbell, CA
 (408) 377-2988
 tdsbay@cs.com

File Name : 11AM FINAL
 Site Code : 0000011
 Start Date : 5/22/2013
 Page No : 1

Groups Printed- Vehicles

Start Time	EL CAMINO REAL Southbound					RALSTON AVE Westbound					EL CAMINO REAL Northbound					RALSTON AVE Eastbound					Int. Total
	Right	Thru	Left	Peds	App. Total	Right	Thru	Left	Peds	App. Total	Right	Thru	Left	Peds	App. Total	Right	Thru	Left	Peds	App. Total	
07:00 AM	7	118	52	10	187	26	75	43	2	146	20	53	5	6	84	7	133	27	0	167	584
07:15 AM	16	179	59	1	255	27	87	22	0	136	29	101	15	0	145	7	175	18	1	201	737
07:30 AM	26	170	67	4	267	34	113	48	3	198	24	136	10	5	175	10	201	45	4	260	900
07:45 AM	10	261	85	8	364	33	126	41	3	203	40	179	20	12	251	15	179	50	9	253	1071
Total	59	728	263	23	1073	120	401	154	8	683	113	469	50	23	655	39	688	140	14	881	3292
08:00 AM	20	206	76	13	315	49	121	33	1	204	49	116	21	13	199	9	179	49	3	240	958
08:15 AM	20	256	87	7	370	38	123	43	2	206	37	166	23	3	229	6	191	28	7	232	1037
08:30 AM	25	199	68	6	298	45	160	39	2	246	47	109	24	3	183	13	211	32	6	262	989
08:45 AM	23	232	70	11	336	45	113	36	2	196	52	162	17	12	243	19	192	33	7	251	1026
Total	88	893	301	37	1319	177	517	151	7	852	185	553	85	31	854	47	773	142	23	985	4010
Grand Total	147	1621	564	60	2392	297	918	305	15	1535	298	1022	135	54	1509	86	1461	282	37	1866	7302
Apprch %	6.1	67.8	23.6	2.5		19.3	59.8	19.9	1		19.7	67.7	8.9	3.6		4.6	78.3	15.1	2		
Total %	2	22.2	7.7	0.8	32.8	4.1	12.6	4.2	0.2	21	4.1	14	1.8	0.7	20.7	1.2	20	3.9	0.5	25.6	

Start Time	EL CAMINO REAL Southbound					RALSTON AVE Westbound					EL CAMINO REAL Northbound					RALSTON AVE Eastbound					Int. Total
	Right	Thru	Left	Peds	App. Total	Right	Thru	Left	Peds	App. Total	Right	Thru	Left	Peds	App. Total	Right	Thru	Left	Peds	App. Total	
Peak Hour Analysis From 07:00 AM to 08:45 AM - Peak 1 of 1																					
Peak Hour for Entire Intersection Begins at 07:45 AM																					
07:45 AM	10	261	85	356		33	126	41	200		40	179	20	239		15	179	50	244	1039	
08:00 AM	20	206	76	302		49	121	33	203		49	116	21	186		9	179	49	237	928	
08:15 AM	20	256	87	363		38	123	43	204		37	166	23	226		6	191	28	225	1018	
08:30 AM	25	199	68	292		45	160	39	244		47	109	24	180		13	211	32	256	972	
Total Volume	75	922	316	1313		165	530	156	851		173	570	88	831		43	760	159	962	3957	
% App. Total	5.7	70.2	24.1			19.4	62.3	18.3			20.8	68.6	10.6			4.5	79	16.5			
PHF	.750	.883	.908	.904		.842	.828	.907	.872		.883	.796	.917	.869		.717	.900	.795	.939	.952	

Traffic Data Service

Campbell, CA
 (408) 377-2988
 tdsbay@cs.com

File Name : 11AM FINAL
 Site Code : 00000011
 Start Date : 5/22/2013
 Page No : 2

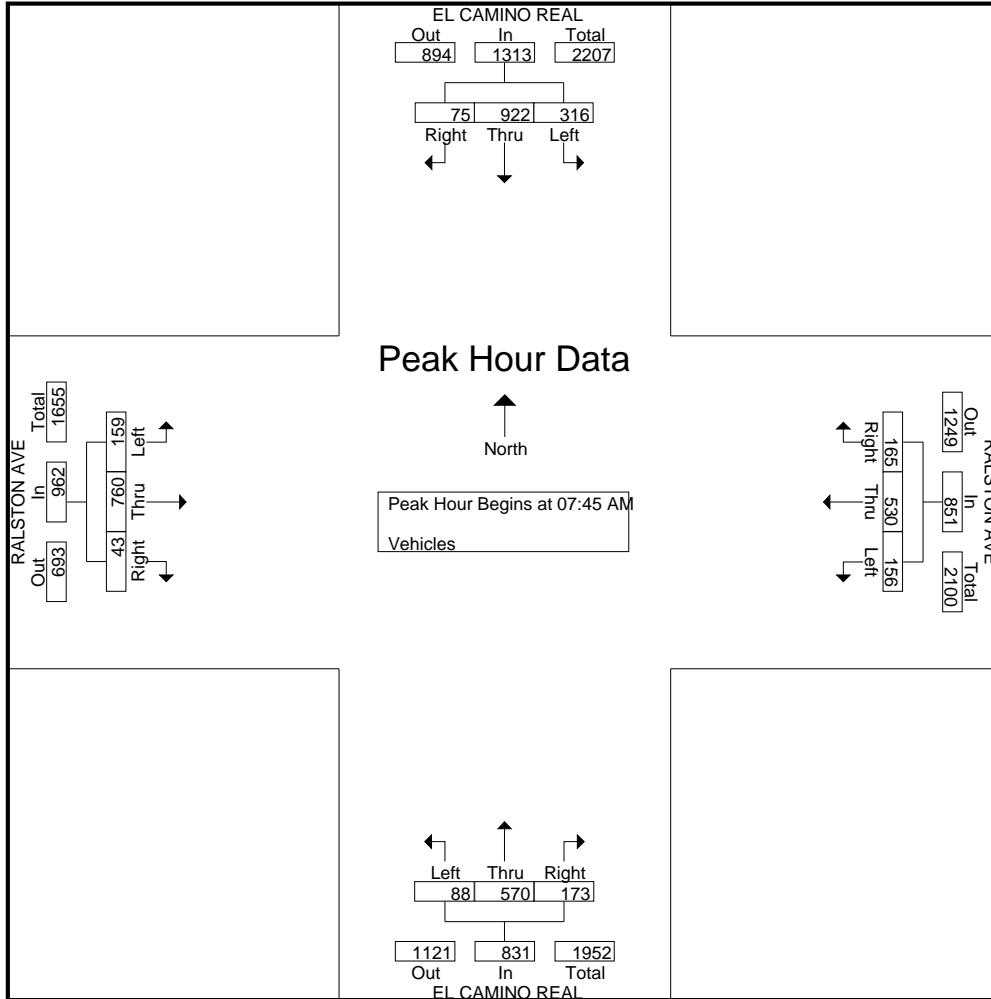

Traffic Data Service

Campbell, CA
 (408) 377-2988
 tdsbay@cs.com

File Name : 11AM FINAL
 Site Code : 00000011
 Start Date : 5/22/2013
 Page No : 1

Groups Printed- Bikes

Start Time	EL CAMINO REAL Southbound					RALSTON AVE Westbound					EL CAMINO REAL Northbound					RALSTON AVE Eastbound					Int. Total					
	Right	Thru	Left	Peds	App. Total	Right	Thru	Left	Peds	App. Total	Right	Thru	Left	Peds	App. Total	Right	Thru	Left	Peds	App. Total						
07:00 AM	0	1	0	0	1	0	0	0	0	0	0	1	0	0	1	0	0	0	0	0	0	0	0	0	0	2
07:15 AM	0	0	0	0	0	0	0	0	0	0	0	0	0	0	0	0	0	0	0	0	0	0	0	0	0	0
07:30 AM	0	0	0	0	0	0	0	0	0	0	0	0	0	0	0	0	2	0	0	0	0	2	0	0	2	2
07:45 AM	1	0	0	0	1	0	0	0	0	0	0	0	0	0	0	0	1	0	0	0	0	1	0	0	1	2
Total	1	1	0	0	2	0	0	0	0	0	0	1	0	0	1	0	3	0	0	0	0	3	0	0	6	
08:00 AM	0	0	0	0	0	0	0	0	0	0	0	0	0	0	0	1	0	0	0	0	1	0	0	0	1	1
08:15 AM	0	1	0	0	1	1	0	0	0	1	0	0	0	0	0	2	0	0	0	0	2	0	0	0	4	4
08:30 AM	0	1	0	0	1	0	3	0	0	3	0	0	0	0	0	1	0	0	0	0	1	0	0	0	5	5
08:45 AM	0	0	0	0	0	0	0	0	0	0	0	0	0	0	0	0	3	2	0	0	0	5	2	0	5	5
Total	0	2	0	0	2	1	3	0	0	4	0	0	0	0	0	4	3	2	0	0	9	15				
Grand Total	1	3	0	0	4	1	3	0	0	4	0	1	0	0	1	4	6	2	0	12					21	
Apprch %	25	75	0	0		25	75	0	0		0	100	0	0		33.3	50	16.7	0							
Total %	4.8	14.3	0	0	19	4.8	14.3	0	0	19	0	4.8	0	0	4.8	19	28.6	9.5	0	57.1						

Start Time	EL CAMINO REAL Southbound				RALSTON AVE Westbound				EL CAMINO REAL Northbound				RALSTON AVE Eastbound				Int. Total
	Right	Thru	Left	App. Total	Right	Thru	Left	App. Total	Right	Thru	Left	App. Total	Right	Thru	Left	App. Total	
Peak Hour Analysis From 07:00 AM to 08:45 AM - Peak 1 of 1																	
Peak Hour for Entire Intersection Begins at 08:00 AM																	
08:00 AM	0	0	0	0	0	0	0	0	0	0	0	0	1	0	0	1	1
08:15 AM	0	1	0	1	1	0	0	1	0	0	0	0	2	0	0	2	4
08:30 AM	0	1	0	1	0	3	0	3	0	0	0	0	1	0	0	1	5
08:45 AM	0	0	0	0	0	0	0	0	0	0	0	0	0	3	2	5	5
Total Volume	0	2	0	2	1	3	0	4	0	0	0	0	4	3	2	9	15
% App. Total	0	100	0		25	75	0		0	0	0		44.4	33.3	22.2		
PHF	.000	.500	.000	.500	.250	.250	.000	.333	.000	.000	.000	.000	.500	.250	.250	.450	.750

Traffic Data Service

Campbell, CA
(408) 377-2988
tdsbay@cs.com

File Name : 11AM FINAL
Site Code : 00000011
Start Date : 5/22/2013
Page No : 2

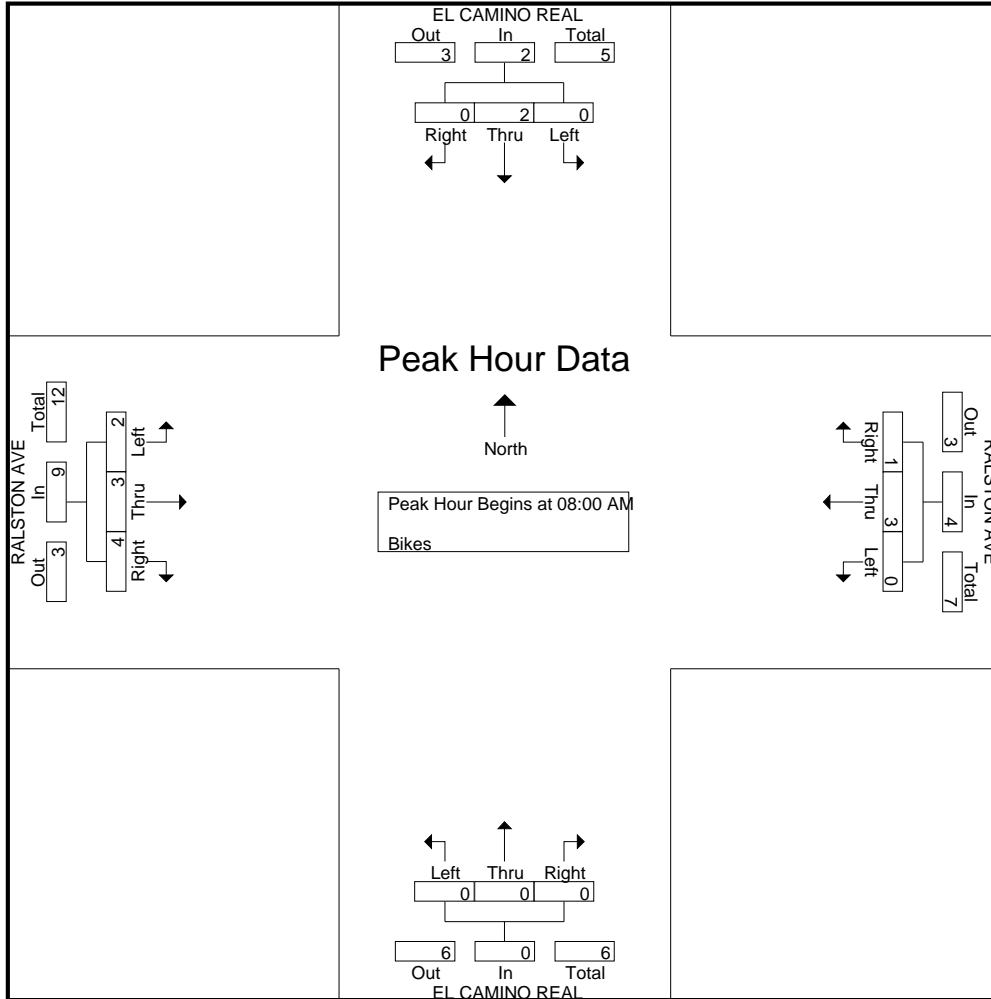

Traffic Data Service

Campbell, CA
 (408) 377-2988
 tdsbay@cs.com

File Name : 11PM FINAL
 Site Code : 00000011
 Start Date : 5/22/2013
 Page No : 1

Groups Printed- Bikes

Start Time	EL CAMINO REAL Southbound					RALSTON AVE Westbound					EL CAMINO REAL Northbound					RALSTON AVE Eastbound					Int. Total
	Right	Thru	Left	Peds	App. Total	Right	Thru	Left	Peds	App. Total	Right	Thru	Left	Peds	App. Total	Right	Thru	Left	Peds	App. Total	
04:00 PM	0	0	0	0	0	0	1	0	0	1	0	0	0	0	0	0	0	0	0	0	1
04:15 PM	0	0	0	0	0	0	0	0	0	0	0	1	0	0	1	0	1	0	0	1	2
04:30 PM	1	0	0	0	1	0	1	0	0	1	0	0	0	0	0	0	0	0	0	0	2
04:45 PM	0	1	0	0	1	0	0	0	0	0	0	0	0	0	0	0	0	0	0	0	1
Total	1	1	0	0	2	0	2	0	0	2	0	1	0	0	1	0	1	0	0	1	6
05:00 PM	0	0	0	0	0	0	2	0	0	2	0	0	0	0	0	0	0	0	0	0	2
05:15 PM	1	0	0	0	1	1	0	0	0	1	0	0	0	0	0	0	0	0	0	0	2
05:30 PM	0	0	0	0	0	0	3	0	0	3	0	0	0	0	0	0	0	0	0	0	3
05:45 PM	0	0	0	0	0	0	1	0	0	1	0	0	0	0	0	0	0	0	0	0	1
Total	1	0	0	0	1	1	6	0	0	7	0	0	0	0	0	0	0	0	0	0	8
Grand Total	2	1	0	0	3	1	8	0	0	9	0	1	0	0	1	0	1	0	0	1	14
Apprch %	66.7	33.3	0	0		11.1	88.9	0	0		0	100	0	0		0	100	0	0		
Total %	14.3	7.1	0	0	21.4	7.1	57.1	0	0	64.3	0	7.1	0	0	7.1	0	7.1	0	0	7.1	

Start Time	EL CAMINO REAL Southbound					RALSTON AVE Westbound					EL CAMINO REAL Northbound					RALSTON AVE Eastbound					Int. Total
	Right	Thru	Left	Peds	App. Total	Right	Thru	Left	Peds	App. Total	Right	Thru	Left	Peds	App. Total	Right	Thru	Left	Peds	App. Total	
04:45 PM	0	1	0	0	1	0	0	0	0	0	0	0	0	0	0	0	0	0	0	0	1
05:00 PM	0	0	0	0	0	0	2	0	0	2	0	0	0	0	0	0	0	0	0	0	2
05:15 PM	1	0	0	0	1	1	0	0	0	1	0	0	0	0	0	0	0	0	0	0	2
05:30 PM	0	0	0	0	0	0	3	0	0	3	0	0	0	0	0	0	0	0	0	0	3
Total Volume	1	1	0	0	2	1	5	0	0	6	0	0	0	0	0	0	0	0	0	0	8
% App. Total	50	50	0	0		16.7	83.3	0	0		0	0	0	0		0	0	0	0		
PHF	.250	.250	.000	.000	.500	.250	.417	.000	.000	.500	.000	.000	.000	.000	.000	.000	.000	.000	.000	.000	.667

Peak Hour Analysis From 04:00 PM to 05:45 PM - Peak 1 of 1

Peak Hour for Entire Intersection Begins at 04:45 PM

Traffic Data Service

Campbell, CA

(408) 377-2988

tdsbay@cs.com

File Name : 11PM FINAL

Site Code : 00000011

Start Date : 5/22/2013

Page No : 2

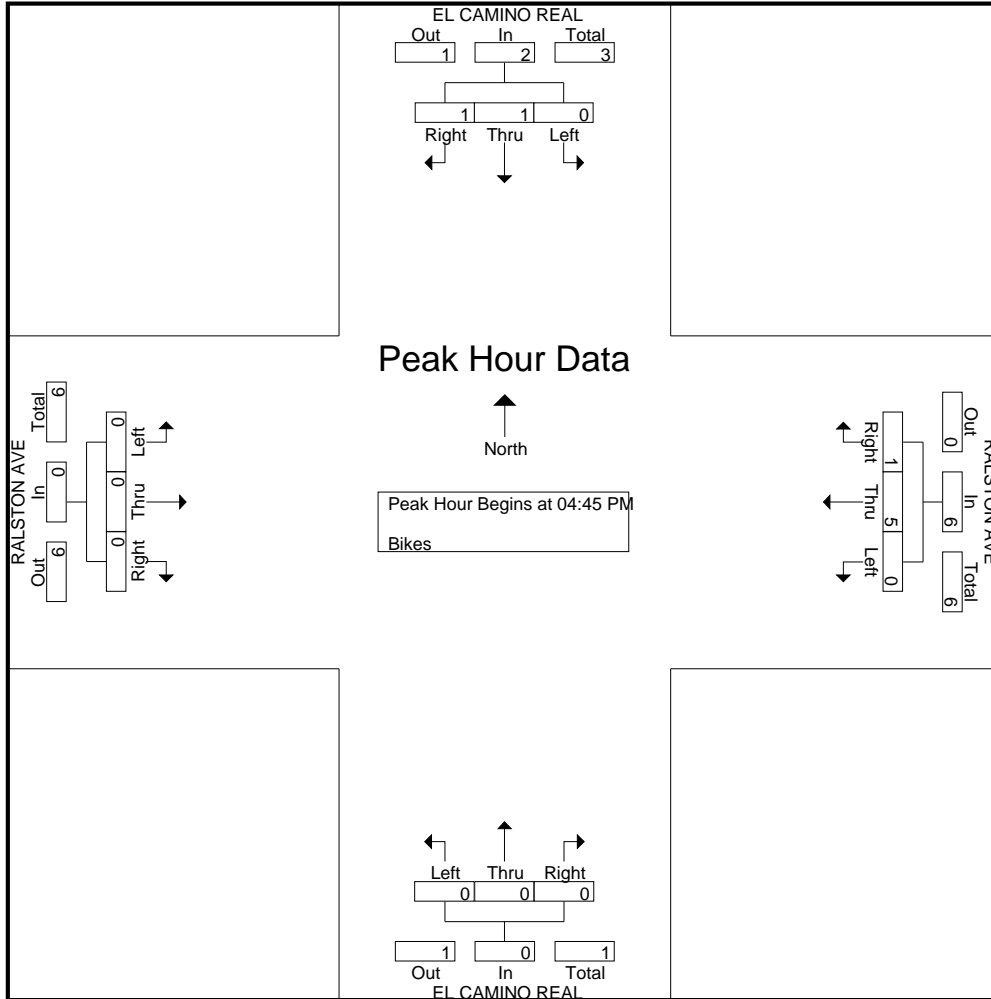

All Traffic Data

(916) 771-8700

City of Burlingame

File Name : 12-7153-008 Arundel-Peninsula

Site Code : 00000000

Start Date : 4/18/2012

Page No : 1

Groups Printed- Unshifted

Start Time	Arundel Road Southbound				Peninsula Avenue Westbound				Arundel Road Northbound				Peninsula Avenue Eastbound				Int. Total
	Left	Thru	Right	App. Total	Left	Thru	Right	App. Total	Left	Thru	Right	App. Total	Left	Thru	Right	App. Total	
07:00	3	0	0	3	9	66	2	77	2	0	10	12	0	100	4	104	196
07:15	3	1	1	5	2	82	5	89	3	1	17	21	0	88	2	90	205
07:30	2	0	1	3	5	97	2	104	8	0	13	21	0	127	10	137	265
07:45	2	5	3	10	8	137	6	151	8	1	17	26	2	139	8	149	336
Total	10	6	5	21	24	382	15	421	21	2	57	80	2	454	24	480	1002
08:00	4	1	1	6	14	145	10	169	7	0	18	25	3	139	9	151	351
08:15	4	1	0	5	4	154	4	162	7	6	7	20	2	136	8	146	333
08:30	4	2	2	8	7	115	2	124	2	1	8	11	1	140	10	151	294
08:45	7	1	1	9	19	149	5	173	8	1	21	30	1	116	21	138	350
Total	19	5	4	28	44	563	21	628	24	8	54	86	7	531	48	586	1328
16:00	4	4	2	10	16	132	5	153	6	2	13	21	3	133	14	150	334
16:15	1	1	3	5	13	129	2	144	2	2	10	14	1	127	6	134	297
16:30	1	3	1	5	14	138	6	158	8	2	5	15	1	121	14	136	314
16:45	1	1	1	3	11	158	5	174	5	0	9	14	1	109	10	120	311
Total	7	9	7	23	54	557	18	629	21	6	37	64	6	490	44	540	1256
17:00	4	2	0	6	19	141	4	164	3	1	11	15	0	148	12	160	345
17:15	2	1	0	3	10	159	7	176	10	3	10	23	5	149	11	165	367
17:30	2	2	3	7	13	162	4	179	8	3	17	28	1	148	11	160	374
17:45	3	2	7	12	12	172	6	190	1	0	8	9	1	117	9	127	338
Total	11	7	10	28	54	634	21	709	22	7	46	75	7	562	43	612	1424
Grand Total	47	27	26	100	176	2136	75	2387	88	23	194	305	22	2037	159	2218	5010
Apprch %	47	27	26		7.4	89.5	3.1		28.9	7.5	63.6		1	91.8	7.2		
Total %	0.9	0.5	0.5	2	3.5	42.6	1.5	47.6	1.8	0.5	3.9	6.1	0.4	40.7	3.2	44.3	

Start Time	Arundel Road Southbound				Peninsula Avenue Westbound				Arundel Road Northbound				Peninsula Avenue Eastbound				Int. Total
	Left	Thru	Right	App. Total	Left	Thru	Right	App. Total	Left	Thru	Right	App. Total	Left	Thru	Right	App. Total	
Peak Hour Analysis From 07:00 to 08:45 - Peak 1 of 1																	
Peak Hour for Entire Intersection Begins at 08:00																	
08:00	4	1	1	6	14	145	10	169	7	0	18	25	3	139	9	151	351
08:15	4	1	0	5	4	154	4	162	7	6	7	20	2	136	8	146	333
08:30	4	2	2	8	7	115	2	124	2	1	8	11	1	140	10	151	294
08:45	7	1	1	9	19	149	5	173	8	1	21	30	1	116	21	138	350
Total Volume	19	5	4	28	44	563	21	628	24	8	54	86	7	531	48	586	1328
% App. Total	67.9	17.9	14.3		7	89.6	3.3		27.9	9.3	62.8		1.2	90.6	8.2		

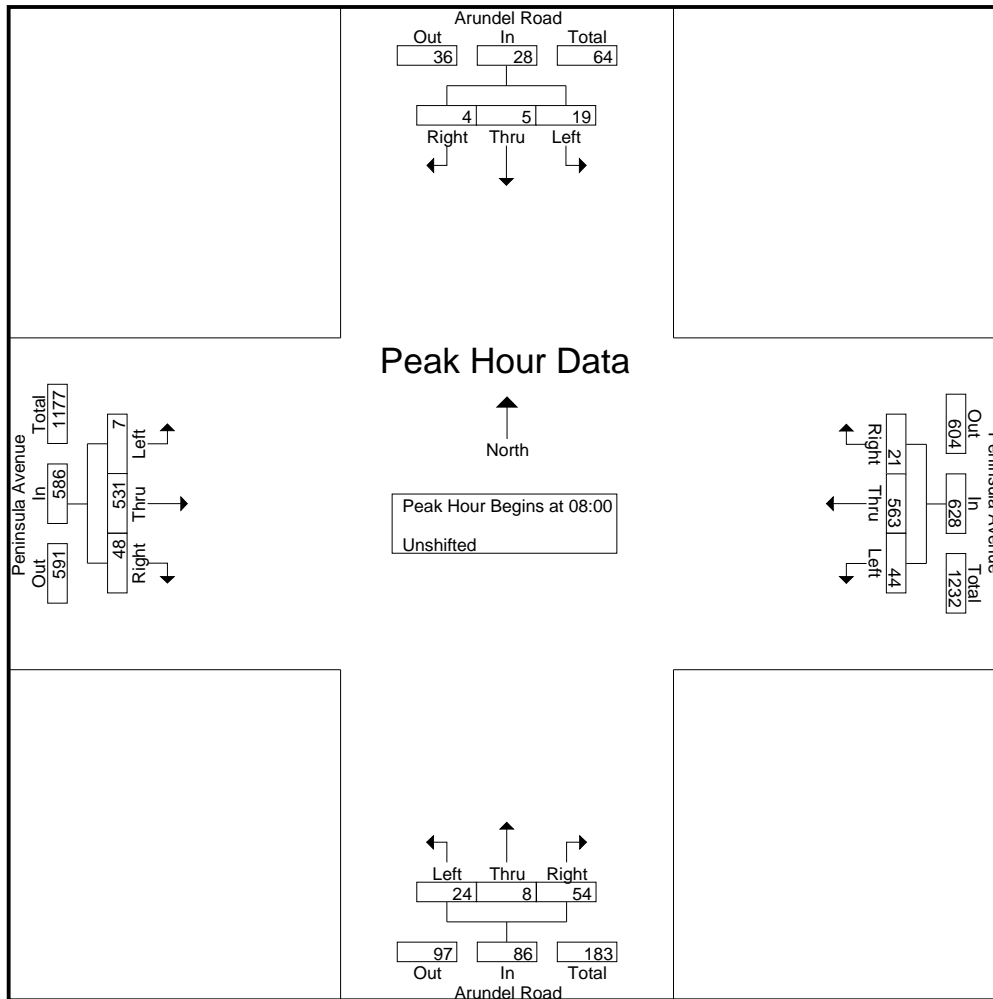

Peak Hour Analysis From 16:00 to 17:45 - Peak 1 of 1
 Peak Hour for Entire Intersection Begins at 17:00

17:00	4	2	0	6	19	141	4	164	3	1	11	15	0	148	12	160	345
17:15	2	1	0	3	10	159	7	176	10	3	10	23	5	149	11	165	367
17:30	2	2	3	7	13	162	4	179	8	3	17	28	1	148	11	160	374
17:45	3	2	7	12	12	172	6	190	1	0	8	9	1	117	9	127	338
Total Volume	11	7	10	28	54	634	21	709	22	7	46	75	7	562	43	612	1424
% App. Total	39.3	25	35.7		7.6	89.4	3		29.3	9.3	61.3		1.1	91.8	7		
PHF	.688	.875	.357	.583	.711	.922	.750	.933	.550	.583	.676	.670	.350	.943	.896	.927	.952

All Traffic Data

(916) 771-8700

City of Burlingame

File Name : 12-7153-008 Arundel-Peninsula

Site Code : 00000000

Start Date : 4/18/2012

Page No : 3

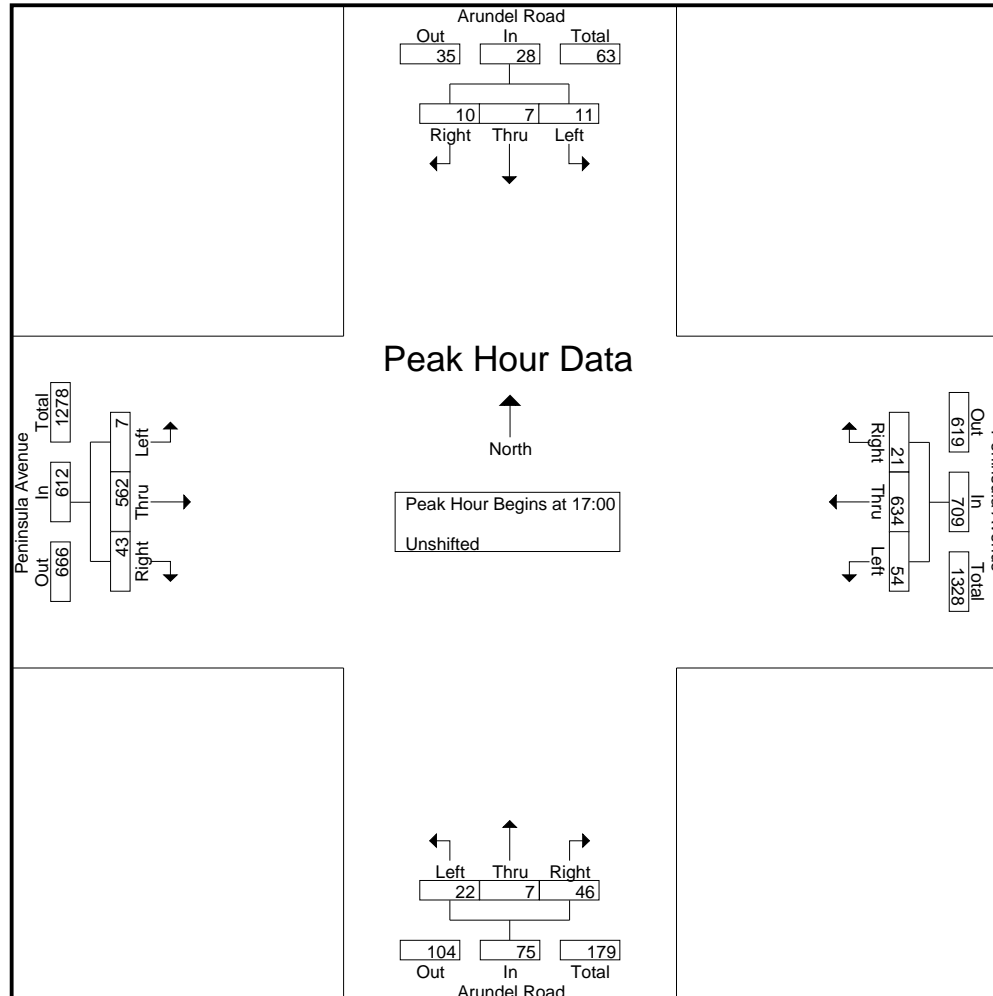

Traffic Data Service

Campbell, CA
 (408) 377-2988
 tdsbay@cs.com

File Name : 12AM FINAL
 Site Code : 00000012
 Start Date : 5/22/2013
 Page No : 1

Groups Printed- Vehicles

Start Time	EL CAMINO REAL Southbound					DRIVEWAY Westbound					EL CAMINO REAL Northbound					SAN CARLOS AVE Eastbound					Int. Total
	Right	Thru	Left	Peds	App. Total	Right	Thru	Left	Peds	App. Total	Right	Thru	Left	Peds	App. Total	Right	Thru	Left	Peds	App. Total	
07:00 AM	35	103	12	0	150	6	4	7	1	18	5	72	8	26	111	29	17	93	3	142	421
07:15 AM	38	183	3	0	224	6	3	5	6	20	2	106	7	41	156	34	3	73	4	114	514
07:30 AM	60	172	15	0	247	6	5	1	3	15	4	149	11	25	189	44	7	94	2	147	598
07:45 AM	71	227	9	0	307	9	4	5	4	22	2	151	15	28	196	55	7	99	2	163	688
Total	204	685	39	0	928	27	16	18	14	75	13	478	41	120	652	162	34	359	11	566	2221
08:00 AM	81	213	4	0	298	6	5	2	2	15	2	150	13	29	194	48	18	120	4	190	697
08:15 AM	68	221	1	0	290	3	4	3	5	15	4	178	19	30	231	57	7	104	2	170	706
08:30 AM	65	195	10	0	270	5	2	4	2	13	0	148	26	19	193	57	7	139	0	203	679
08:45 AM	62	238	7	0	307	2	1	2	3	8	4	167	26	26	223	56	7	134	3	200	738
Total	276	867	22	0	1165	16	12	11	12	51	10	643	84	104	841	218	39	497	9	763	2820
Grand Total	480	1552	61	0	2093	43	28	29	26	126	23	1121	125	224	1493	380	73	856	20	1329	5041
Apprch %	22.9	74.2	2.9	0		34.1	22.2	23	20.6		1.5	75.1	8.4	15		28.6	5.5	64.4	1.5		
Total %	9.5	30.8	1.2	0	41.5	0.9	0.6	0.6	0.5	2.5	0.5	22.2	2.5	4.4	29.6	7.5	1.4	17	0.4	26.4	

Start Time	EL CAMINO REAL Southbound				DRIVEWAY Westbound				EL CAMINO REAL Northbound				SAN CARLOS AVE Eastbound				Int. Total
	Right	Thru	Left	App. Total	Right	Thru	Left	App. Total	Right	Thru	Left	App. Total	Right	Thru	Left	App. Total	
08:00 AM	81	213	4	298	6	5	2	13	2	150	13	165	48	18	120	186	662
08:15 AM	68	221	1	290	3	4	3	10	4	178	19	201	57	7	104	168	669
08:30 AM	65	195	10	270	5	2	4	11	0	148	26	174	57	7	139	203	658
08:45 AM	62	238	7	307	2	1	2	5	4	167	26	197	56	7	134	197	706
Total Volume	276	867	22	1165	16	12	11	39	10	643	84	737	218	39	497	754	2695
% App. Total	23.7	74.4	1.9		41	30.8	28.2		1.4	87.2	11.4		28.9	5.2	65.9		
PHF	.852	.911	.550	.949	.667	.600	.688	.750	.625	.903	.808	.917	.956	.542	.894	.929	.954

Peak Hour Analysis From 07:00 AM to 08:45 AM - Peak 1 of 1

Peak Hour for Entire Intersection Begins at 08:00 AM

Traffic Data Service

Campbell, CA
 (408) 377-2988
 tdsbay@cs.com

File Name : 12AM FINAL
 Site Code : 00000012
 Start Date : 5/22/2013
 Page No : 2

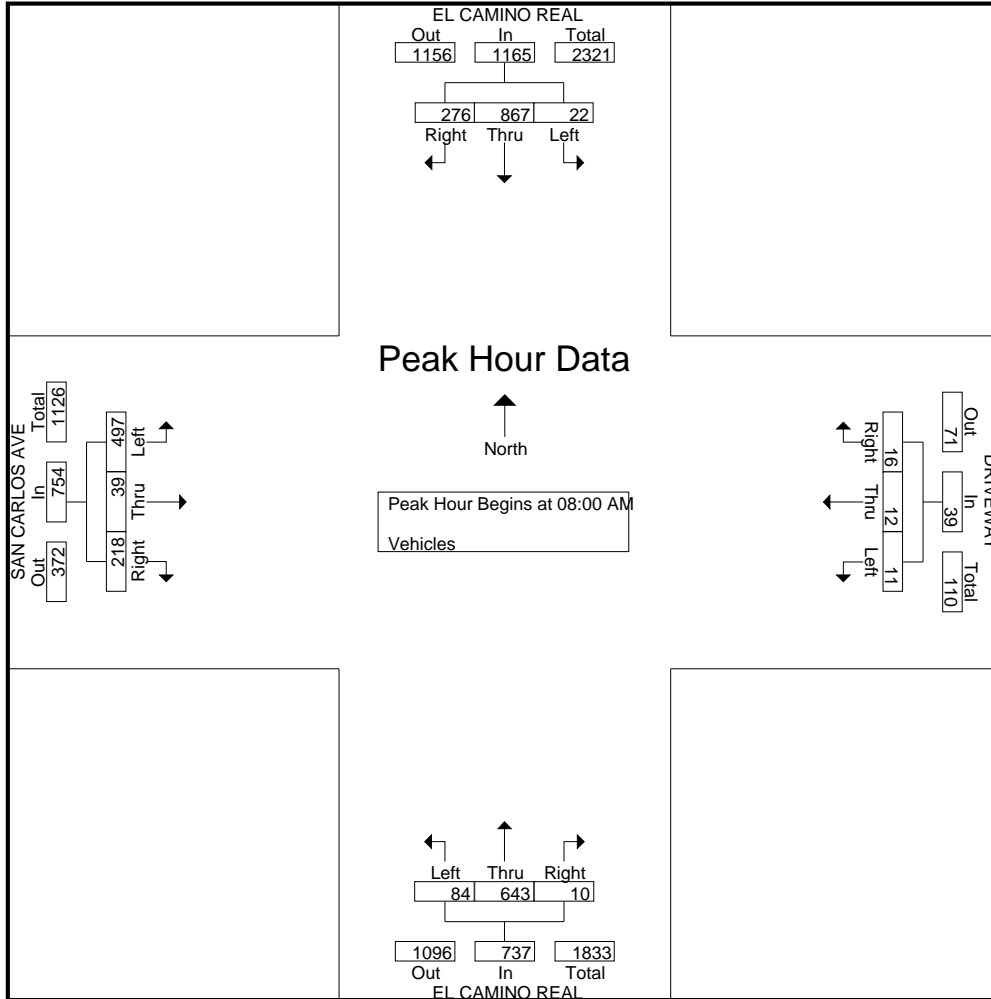

Traffic Data Service

Campbell, CA
 (408) 377-2988
 tdsbay@cs.com

File Name : 12AM FINAL
 Site Code : 00000012
 Start Date : 5/22/2013
 Page No : 1

Groups Printed- Bikes

Start Time	EL CAMINO REAL Southbound					DRIVEWAY Westbound					EL CAMINO REAL Northbound					SAN CARLOS AVE Eastbound					Int. Total
	Right	Thru	Left	Peds	App. Total	Right	Thru	Left	Peds	App. Total	Right	Thru	Left	Peds	App. Total	Right	Thru	Left	Peds	App. Total	
07:00 AM	0	0	0	0	0	0	0	0	0	0	0	0	0	0	0	0	2	0	0	2	2
07:15 AM	0	0	0	0	0	0	1	0	0	1	0	0	0	0	0	0	3	0	0	3	4
07:30 AM	0	0	0	0	0	0	0	0	0	0	0	0	0	0	0	0	1	0	0	1	1
07:45 AM	0	0	0	0	0	0	0	0	0	0	0	0	0	0	0	0	2	0	0	2	2
Total	0	0	0	0	0	0	1	0	0	1	0	0	0	0	0	0	8	0	0	8	9
08:00 AM	0	0	0	0	0	0	0	0	0	0	0	0	0	0	0	0	5	2	0	7	7
08:15 AM	0	1	0	0	1	0	0	0	0	0	0	0	0	0	0	0	4	0	0	4	5
08:30 AM	0	0	0	0	0	0	0	0	0	0	0	0	0	0	0	0	1	0	0	1	1
08:45 AM	0	0	0	0	0	0	0	0	0	0	0	1	0	0	1	0	1	0	0	1	2
Total	0	1	0	0	1	0	0	0	0	0	0	1	0	0	1	0	11	2	0	13	15
Grand Total	0	1	0	0	1	0	1	0	0	1	0	1	0	0	1	0	19	2	0	21	24
Apprch %	0	100	0	0		0	100	0	0		0	100	0	0		0	90.5	9.5	0		
Total %	0	4.2	0	0	4.2	0	4.2	0	0	4.2	0	4.2	0	0	4.2	0	79.2	8.3	0	87.5	

Start Time	EL CAMINO REAL Southbound					DRIVEWAY Westbound					EL CAMINO REAL Northbound					SAN CARLOS AVE Eastbound					Int. Total
	Right	Thru	Left	Peds	App. Total	Right	Thru	Left	Peds	App. Total	Right	Thru	Left	Peds	App. Total	Right	Thru	Left	Peds	App. Total	
07:30 AM	0	0	0	0	0	0	0	0	0	0	0	0	0	0	0	0	1	0	0	1	1
07:45 AM	0	0	0	0	0	0	0	0	0	0	0	0	0	0	0	0	2	0	0	2	2
08:00 AM	0	0	0	0	0	0	0	0	0	0	0	0	0	0	0	0	5	2	0	7	7
08:15 AM	0	1	0	0	1	0	0	0	0	0	0	0	0	0	0	0	4	0	0	4	5
Total Volume	0	1	0	0	1	0	0	0	0	0	0	0	0	0	0	0	12	2	0	14	15
% App. Total	0	100	0	0		0	0	0	0		0	0	0	0		0	85.7	14.3	0		
PHF	.000	.250	.000	.000	.250	.000	.000	.000	.000	.000	.000	.000	.000	.000	.000	.000	.600	.250	.500	.536	

Peak Hour Analysis From 07:00 AM to 08:45 AM - Peak 1 of 1

Peak Hour for Entire Intersection Begins at 07:30 AM

Traffic Data Service

Campbell, CA

(408) 377-2988

tdsbay@cs.com

File Name : 12AM FINAL

Site Code : 00000012

Start Date : 5/22/2013

Page No : 2

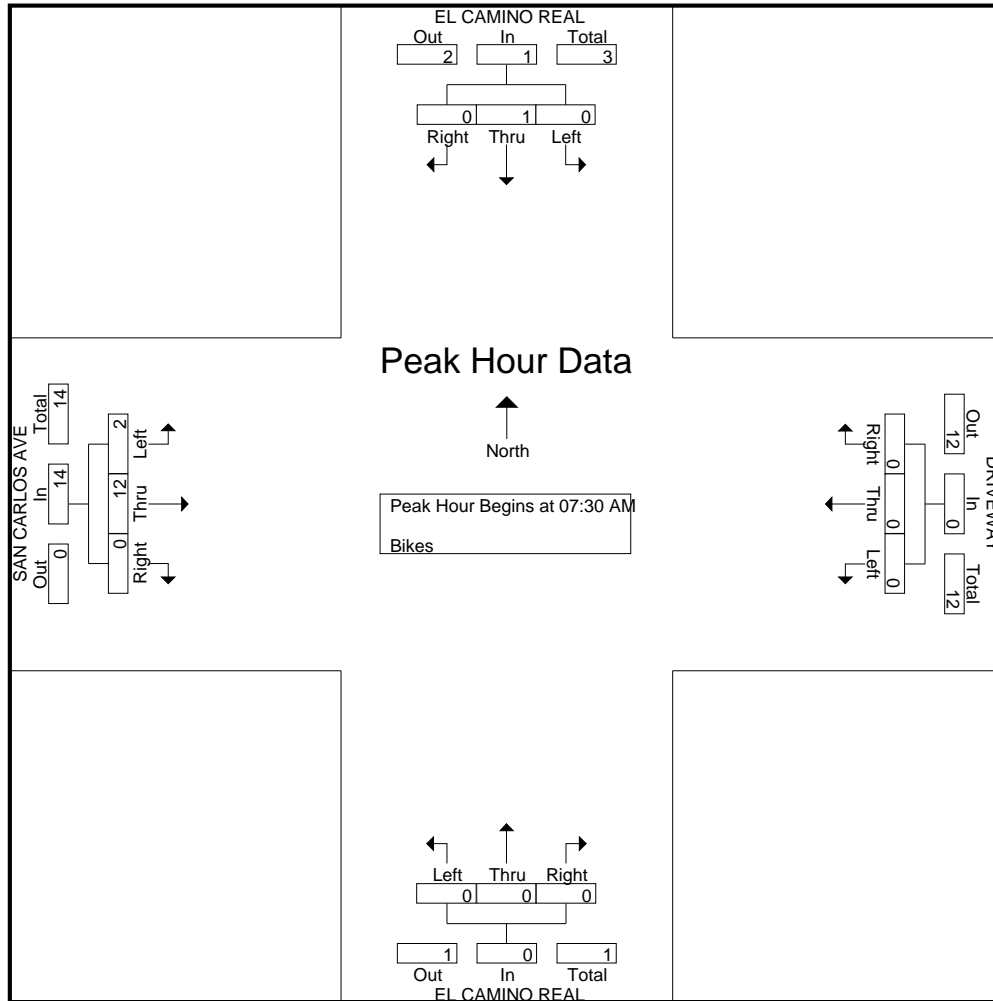

Traffic Data Service

Campbell, CA
 (408) 377-2988
 tdsbay@cs.com

File Name : 12PM FINAL
 Site Code : 00000012
 Start Date : 5/22/2013
 Page No : 1

Groups Printed- Vehicles

Start Time	EL CAMINO REAL Southbound					DRIVEWAY Westbound					EL CAMINO REAL Northbound					SAN CARLOS AVE Eastbound					Int. Total
	Right	Thru	Left	Peds	App. Total	Right	Thru	Left	Peds	App. Total	Right	Thru	Left	Peds	App. Total	Right	Thru	Left	Peds	App. Total	
04:00 PM	84	238	2	0	324	3	3	3	2	11	2	201	38	15	256	44	6	93	6	149	740
04:15 PM	66	225	7	1	299	4	4	3	4	15	1	238	54	31	324	35	1	89	0	125	763
04:30 PM	70	205	7	1	283	11	6	6	1	24	1	233	43	31	308	40	3	91	5	139	754
04:45 PM	76	243	3	0	322	4	4	7	2	17	1	241	54	19	315	34	5	94	0	133	787
Total	296	911	19	2	1228	22	17	19	9	67	5	913	189	96	1203	153	15	367	11	546	3044
05:00 PM	90	218	4	0	312	6	3	3	4	16	1	218	47	31	297	50	2	114	4	170	795
05:15 PM	93	244	3	0	340	3	3	1	3	10	0	293	48	21	362	30	3	77	2	112	824
05:30 PM	107	222	5	0	334	12	9	3	1	25	1	270	54	32	357	41	2	102	1	146	862
05:45 PM	112	248	2	0	362	6	9	6	0	21	3	270	69	50	392	46	5	88	0	139	914
Total	402	932	14	0	1348	27	24	13	8	72	5	1051	218	134	1408	167	12	381	7	567	3395
Grand Total	698	1843	33	2	2576	49	41	32	17	139	10	1964	407	230	2611	320	27	748	18	1113	6439
Apprch %	27.1	71.5	1.3	0.1		35.3	29.5	23	12.2		0.4	75.2	15.6	8.8		28.8	2.4	67.2	1.6		
Total %	10.8	28.6	0.5	0	40	0.8	0.6	0.5	0.3	2.2	0.2	30.5	6.3	3.6	40.5	5	0.4	11.6	0.3	17.3	

Start Time	EL CAMINO REAL Southbound				DRIVEWAY Westbound				EL CAMINO REAL Northbound				SAN CARLOS AVE Eastbound				Int. Total
	Right	Thru	Left	App. Total	Right	Thru	Left	App. Total	Right	Thru	Left	App. Total	Right	Thru	Left	App. Total	
Peak Hour Analysis From 04:00 PM to 05:45 PM - Peak 1 of 1																	
Peak Hour for Entire Intersection Begins at 05:00 PM																	
05:00 PM	90	218	4	312	6	3	3	12	1	218	47	266	50	2	114	166	756
05:15 PM	93	244	3	340	3	3	1	7	0	293	48	341	30	3	77	110	798
05:30 PM	107	222	5	334	12	9	3	24	1	270	54	325	41	2	102	145	828
05:45 PM	112	248	2	362	6	9	6	21	3	270	69	342	46	5	88	139	864
Total Volume	402	932	14	1348	27	24	13	64	5	1051	218	1274	167	12	381	560	3246
% App. Total	29.8	69.1	1		42.2	37.5	20.3		0.4	82.5	17.1		29.8	2.1	68		
PHF	.897	.940	.700	.931	.563	.667	.542	.667	.417	.897	.790	.931	.835	.600	.836	.843	.939

Traffic Data Service

Campbell, CA
 (408) 377-2988
 tdsbay@cs.com

File Name : 12PM FINAL
 Site Code : 00000012
 Start Date : 5/22/2013
 Page No : 2

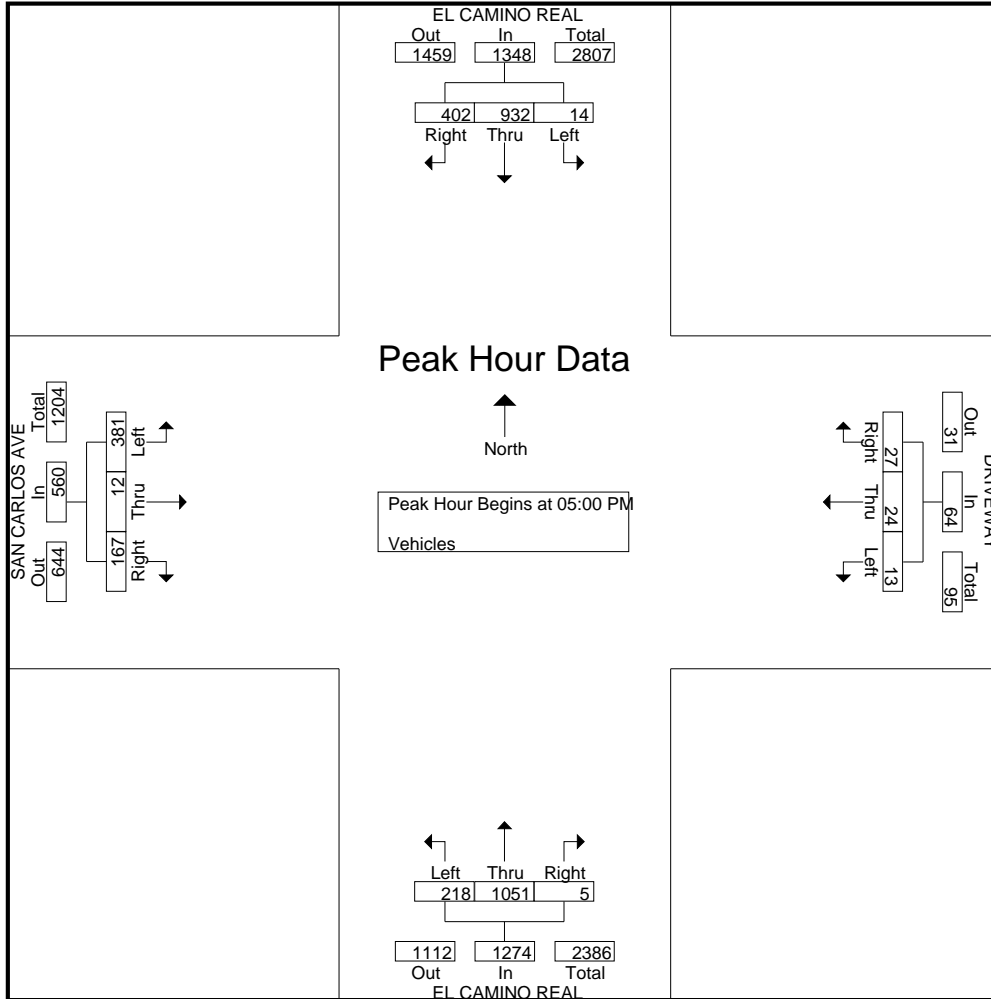

Traffic Data Service

Campbell, CA
(408) 377-2988
tdsbay@cs.com

File Name : 12PM FINAL
Site Code : 00000012
Start Date : 5/22/2013
Page No : 1

Groups Printed- Bikes

Start Time	EL CAMINO REAL Southbound					DRIVEWAY Westbound					EL CAMINO REAL Northbound					SAN CARLOS AVE Eastbound					Int. Total
	Right	Thru	Left	Peds	App. Total	Right	Thru	Left	Peds	App. Total	Right	Thru	Left	Peds	App. Total	Right	Thru	Left	Peds	App. Total	
04:00 PM	0	1	0	0	1	0	0	0	0	0	0	0	0	0	0	0	2	0	0	2	3
04:15 PM	0	0	0	0	0	0	1	2	0	3	0	0	0	0	0	0	0	0	0	0	3
04:30 PM	0	1	0	0	1	0	0	0	0	0	0	0	0	0	0	0	1	0	0	1	2
04:45 PM	0	1	0	0	1	0	0	0	0	0	0	0	0	0	0	0	0	0	0	0	1
Total	0	3	0	0	3	0	1	2	0	3	0	0	0	0	0	0	3	0	0	3	9
05:00 PM	0	0	0	0	0	0	0	0	0	0	0	0	0	0	0	0	0	1	0	1	1
05:15 PM	0	0	0	0	0	0	1	0	0	1	0	0	0	0	0	0	1	0	0	1	2
05:30 PM	0	0	0	0	0	0	2	0	0	2	0	0	0	0	0	0	0	0	0	0	2
05:45 PM	0	0	0	0	0	0	0	0	0	0	0	1	0	0	1	0	0	0	0	0	1
Total	0	0	0	0	0	0	3	0	0	3	0	1	0	0	1	0	1	1	0	2	6
Grand Total	0	3	0	0	3	0	4	2	0	6	0	1	0	0	1	0	4	1	0	5	15
Apprch %	0	100	0	0		0	66.7	33.3	0		0	100	0	0		0	80	20	0		
Total %	0	20	0	0	20	0	26.7	13.3	0	40	0	6.7	0	0	6.7	0	26.7	6.7	0	33.3	

Start Time	EL CAMINO REAL Southbound				DRIVEWAY Westbound				EL CAMINO REAL Northbound				SAN CARLOS AVE Eastbound				Int. Total
	Right	Thru	Left	App. Total	Right	Thru	Left	App. Total	Right	Thru	Left	App. Total	Right	Thru	Left	App. Total	
Peak Hour Analysis From 04:00 PM to 05:45 PM - Peak 1 of 1																	
Peak Hour for Entire Intersection Begins at 04:00 PM																	
04:00 PM	0	1	0	1	0	0	0	0	0	0	0	0	0	2	0	2	3
04:15 PM	0	0	0	0	0	1	2	3	0	0	0	0	0	0	0	0	3
04:30 PM	0	1	0	1	0	0	0	0	0	0	0	0	0	1	0	1	2
04:45 PM	0	1	0	1	0	0	0	0	0	0	0	0	0	0	0	0	1
Total Volume	0	3	0	3	0	1	2	3	0	0	0	0	0	3	0	3	9
% App. Total	0	100	0		0	33.3	66.7		0	0	0		0	100	0		
PHF	.000	.750	.000	.750	.000	.250	.250	.250	.000	.000	.000	.000	.000	.375	.000	.375	.750

Traffic Data Service

Campbell, CA
(408) 377-2988
tdsbay@cs.com

File Name : 12PM FINAL
Site Code : 00000012
Start Date : 5/22/2013
Page No : 2

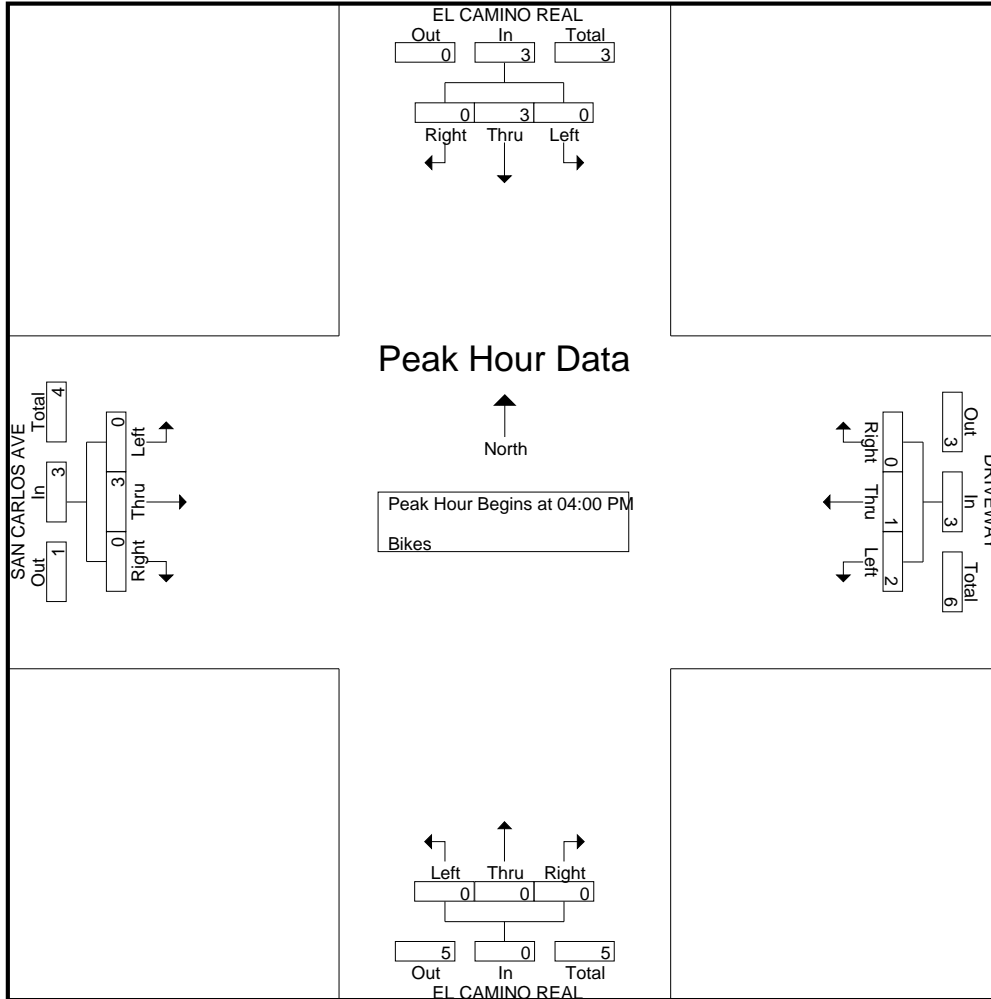

All Traffic Data

(916) 771-8700

City of Redwood City

File Name : 12-7153-020 Main-Maple

Site Code : 00000000

Start Date : 4/17/2012

Page No : 1

Groups Printed- Unshifted

Start Time	Main Street Southbound				Maple Street Westbound				Main Street Northbound				Maple Street Eastbound				Int. Total
	Left	Thru	Right	App. Total	Left	Thru	Right	App. Total	Left	Thru	Right	App. Total	Left	Thru	Right	App. Total	
07:00	0	17	13	30	0	0	0	0	0	26	0	26	24	0	7	31	87
07:15	0	18	12	30	0	0	0	0	0	34	0	34	25	0	4	29	93
07:30	0	27	17	44	1	0	0	1	0	34	0	34	39	0	2	41	120
07:45	0	28	15	43	0	0	1	1	0	62	0	62	40	0	1	41	147
Total	0	90	57	147	1	0	1	2	0	156	0	156	128	0	14	142	447
08:00	0	26	14	40	0	0	2	2	0	53	0	53	48	0	4	52	147
08:15	0	19	18	37	0	0	1	1	0	50	0	50	36	0	3	39	127
08:30	0	23	16	39	2	0	2	4	0	50	0	50	47	0	7	54	147
08:45	0	17	27	44	0	0	3	3	0	59	0	59	38	0	2	40	146
Total	0	85	75	160	2	0	8	10	0	212	0	212	169	0	16	185	567
16:00	0	42	54	96	0	0	2	2	0	49	0	49	35	0	6	41	188
16:15	0	44	37	81	1	0	3	4	0	33	0	33	28	0	3	31	149
16:30	0	60	37	97	1	0	2	3	0	46	0	46	41	0	9	50	196
16:45	0	49	46	95	0	0	1	1	0	51	0	51	37	0	7	44	191
Total	0	195	174	369	2	0	8	10	0	179	0	179	141	0	25	166	724
17:00	0	42	54	96	0	0	2	2	0	57	0	57	30	0	2	32	187
17:15	0	61	54	115	0	0	1	1	0	69	0	69	38	0	2	40	225
17:30	0	61	51	112	0	0	1	1	0	50	0	50	31	0	4	35	198
17:45	0	50	41	91	1	0	0	1	0	56	0	56	34	0	3	37	185
Total	0	214	200	414	1	0	4	5	0	232	0	232	133	0	11	144	795
Grand Total	0	584	506	1090	6	0	21	27	0	779	0	779	571	0	66	637	2533
Apprch %	0	53.6	46.4		22.2	0	77.8		0	100	0		89.6	0	10.4		
Total %	0	23.1	20	43	0.2	0	0.8	1.1	0	30.8	0	30.8	22.5	0	2.6	25.1	

Start Time	Main Street Southbound				Maple Street Westbound				Main Street Northbound				Maple Street Eastbound				Int. Total
	Left	Thru	Right	App. Total	Left	Thru	Right	App. Total	Left	Thru	Right	App. Total	Left	Thru	Right	App. Total	
Peak Hour Analysis From 07:00 to 08:45 - Peak 1 of 1																	
Peak Hour for Entire Intersection Begins at 07:45																	
07:45	0	28	15	43	0	0	1	1	0	62	0	62	40	0	1	41	147
08:00	0	26	14	40	0	0	2	2	0	53	0	53	48	0	4	52	147
08:15	0	19	18	37	0	0	1	1	0	50	0	50	36	0	3	39	127
08:30	0	23	16	39	2	0	2	4	0	50	0	50	47	0	7	54	147
Total Volume	0	96	63	159	2	0	6	8	0	215	0	215	171	0	15	186	568
% App. Total	0	60.4	39.6		25	0	75		0	100	0		91.9	0	8.1		

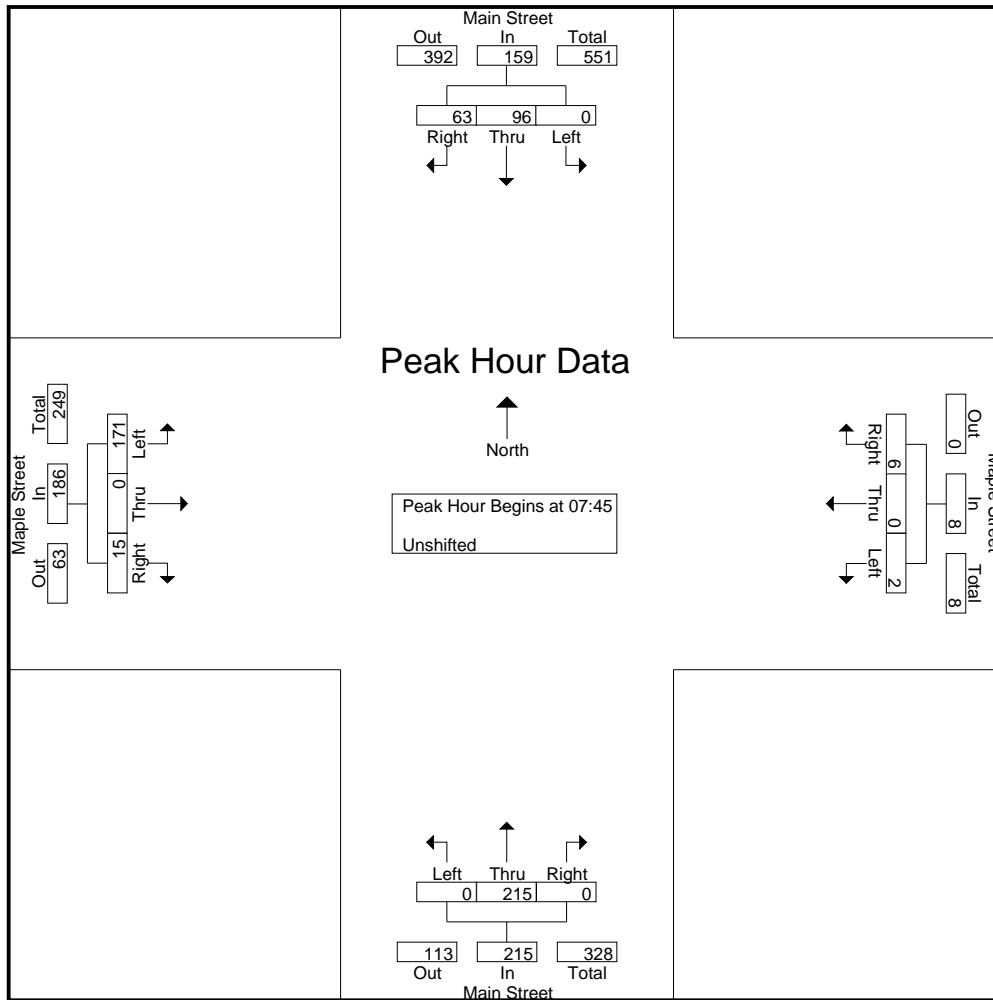

Peak Hour Analysis From 16:00 to 17:45 - Peak 1 of 1
 Peak Hour for Entire Intersection Begins at 16:45

16:45	0	49	46	95	0	0	1	1	0	51	0	51	37	0	7	44	191
17:00	0	42	54	96	0	0	2	2	0	57	0	57	30	0	2	32	187
17:15	0	61	54	115	0	0	1	1	0	69	0	69	38	0	2	40	225
17:30	0	61	51	112	0	0	1	1	0	50	0	50	31	0	4	35	198
Total Volume	0	213	205	418	0	0	5	5	0	227	0	227	136	0	15	151	801
% App. Total	0	51	49		0	0	100		0	100	0		90.1	0	9.9		
PHF	.000	.873	.949	.909	.000	.000	.625	.625	.000	.822	.000	.822	.895	.000	.536	.858	.890

All Traffic Data

(916) 771-8700

City of Redwood City

File Name : 12-7153-020 Main-Maple

Site Code : 00000000

Start Date : 4/17/2012

Page No : 3

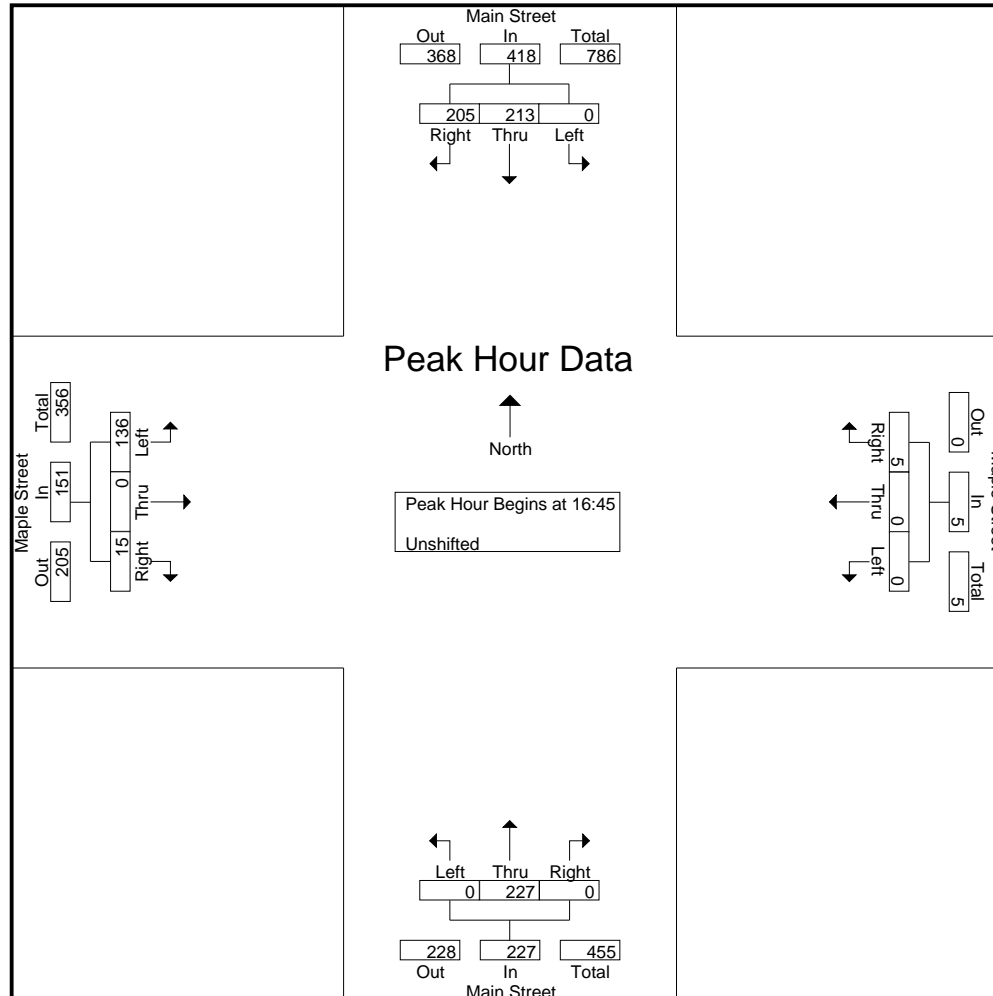

All Traffic Data

(916) 771-8700

City of Redwood City

File Name : 12-7153-018 Main-Beech

Site Code : 00000000

Start Date : 4/17/2012

Page No : 1

Groups Printed- Unshifted

Start Time	Main Street Southbound				Beech Street Westbound				Main Street Northbound				Beech Street Eastbound				Int. Total
	Left	Thru	Right	App. Total	Left	Thru	Right	App. Total	Left	Thru	Right	App. Total	Left	Thru	Right	App. Total	
07:00	0	17	3	20	0	0	0	0	12	28	0	40	2	0	8	10	70
07:15	0	26	1	27	0	0	0	0	12	40	0	52	4	0	13	17	96
07:30	0	34	2	36	0	0	0	0	18	36	0	54	6	0	16	22	112
07:45	0	32	3	35	0	0	0	0	21	72	0	93	4	0	18	22	150
Total	0	109	9	118	0	0	0	0	63	176	0	239	16	0	55	71	428
08:00	0	37	1	38	0	0	0	0	20	59	0	79	2	0	11	13	130
08:15	0	24	5	29	0	0	0	0	16	62	0	78	10	0	17	27	134
08:30	0	29	1	30	0	0	0	0	12	59	0	71	5	0	13	18	119
08:45	0	22	3	25	0	0	0	0	7	65	0	72	6	0	7	13	110
Total	0	112	10	122	0	0	0	0	55	245	0	300	23	0	48	71	493
16:00	0	56	1	57	0	0	0	0	10	57	0	67	5	0	14	19	143
16:15	1	45	1	47	1	0	0	1	11	47	0	58	7	0	12	19	125
16:30	0	61	2	63	0	0	0	0	15	46	0	61	5	1	16	22	146
16:45	0	62	1	63	0	0	0	0	22	70	0	92	7	0	9	16	171
Total	1	224	5	230	1	0	0	1	58	220	0	278	24	1	51	76	585
17:00	0	63	0	63	0	1	0	1	11	73	1	85	4	0	13	17	166
17:15	0	73	5	78	0	0	0	0	17	78	0	95	2	0	13	15	188
17:30	0	80	2	82	0	0	0	0	12	57	0	69	3	0	14	17	168
17:45	1	59	2	62	1	0	2	3	17	58	0	75	6	0	5	11	151
Total	1	275	9	285	1	1	2	4	57	266	1	324	15	0	45	60	673
Grand Total	2	720	33	755	2	1	2	5	233	907	1	1141	78	1	199	278	2179
Apprch %	0.3	95.4	4.4		40	20	40		20.4	79.5	0.1		28.1	0.4	71.6		
Total %	0.1	33	1.5	34.6	0.1	0	0.1	0.2	10.7	41.6	0	52.4	3.6	0	9.1	12.8	

Start Time	Main Street Southbound				Beech Street Westbound				Main Street Northbound				Beech Street Eastbound				Int. Total
	Left	Thru	Right	App. Total	Left	Thru	Right	App. Total	Left	Thru	Right	App. Total	Left	Thru	Right	App. Total	
Peak Hour Analysis From 07:00 to 08:45 - Peak 1 of 1																	
Peak Hour for Entire Intersection Begins at 07:45																	
07:45	0	32	3	35	0	0	0	0	21	72	0	93	4	0	18	22	150
08:00	0	37	1	38	0	0	0	0	20	59	0	79	2	0	11	13	130
08:15	0	24	5	29	0	0	0	0	16	62	0	78	10	0	17	27	134
08:30	0	29	1	30	0	0	0	0	12	59	0	71	5	0	13	18	119
Total Volume	0	122	10	132	0	0	0	0	69	252	0	321	21	0	59	80	533
% App. Total	0	92.4	7.6		0	0	0		21.5	78.5	0		26.2	0	73.8		

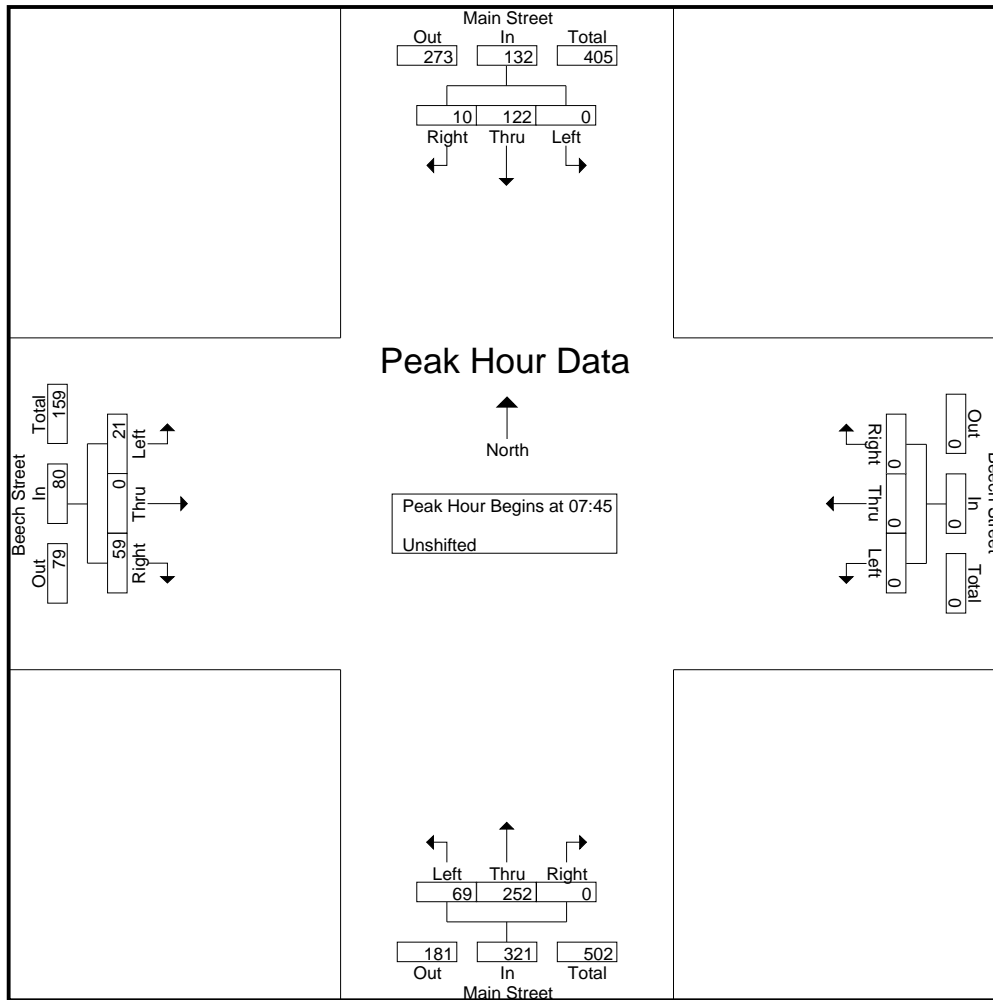

Peak Hour Analysis From 16:00 to 17:45 - Peak 1 of 1
 Peak Hour for Entire Intersection Begins at 16:45

16:45	0	62	1	63	0	0	0	0	22	70	0	92	7	0	9	16	171
17:00	0	63	0	63	0	1	0	1	11	73	1	85	4	0	13	17	166
17:15	0	73	5	78	0	0	0	0	17	78	0	95	2	0	13	15	188
17:30	0	80	2	82	0	0	0	0	12	57	0	69	3	0	14	17	168
Total Volume	0	278	8	286	0	1	0	1	62	278	1	341	16	0	49	65	693
% App. Total	0	97.2	2.8		0	100	0		18.2	81.5	0.3		24.6	0	75.4		
PHF	.000	.869	.400	.872	.000	.250	.000	.250	.705	.891	.250	.897	.571	.000	.875	.956	.922

All Traffic Data

(916) 771-8700

City of Redwood City

File Name : 12-7153-018 Main-Beech

Site Code : 00000000

Start Date : 4/17/2012

Page No : 3

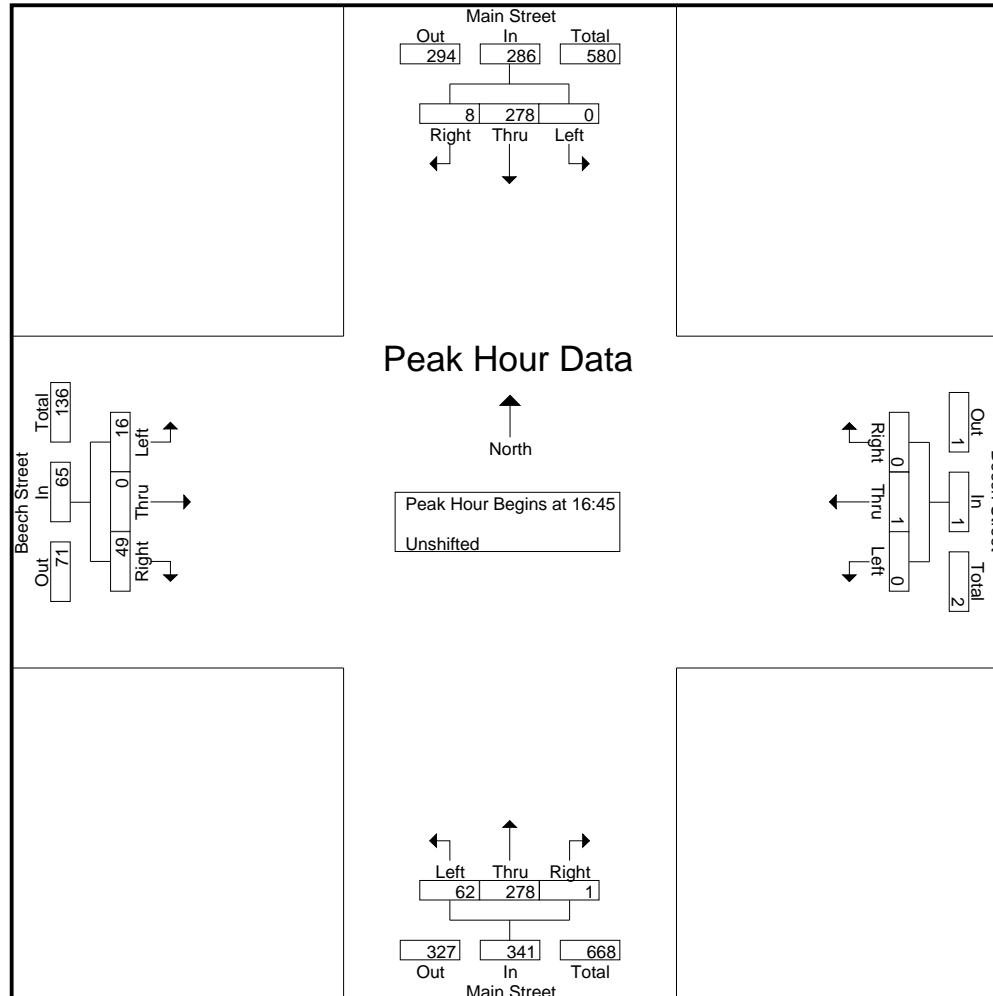

Traffic Data Service

Campbell, CA
 (408) 377-2988
 tdsbay@cs.com

File Name : 3AM FINAL
 Site Code : 00000003
 Start Date : 9/24/2013
 Page No : 1

Groups Printed- Vehicles

Start Time	PALMER LN Southbound					MIDDLEFIELD RD Westbound					FAIR OAKS LN Northbound					MIDDLEFIELD RD Eastbound					Int. Total
	Right	Thru	Left	Peds	App. Total	Right	Thru	Left	Peds	App. Total	Right	Thru	Left	Peds	App. Total	Right	Thru	Left	Peds	App. Total	
07:00 AM	2	2	2	2	8	1	57	32	0	90	12	0	0	0	12	11	84	1	0	96	206
07:15 AM	2	3	1	0	6	0	59	50	0	109	25	0	1	1	27	17	118	1	0	136	278
07:30 AM	9	16	1	1	27	0	79	54	1	134	43	0	0	0	43	20	159	0	0	179	383
07:45 AM	19	26	3	6	54	1	80	44	0	125	40	1	5	0	46	52	136	1	3	192	417
Total	32	47	7	9	95	2	275	180	1	458	120	1	6	1	128	100	497	3	3	603	1284
08:00 AM	13	15	1	2	31	0	106	53	1	160	39	2	5	0	46	18	112	1	0	131	368
08:15 AM	7	9	0	2	18	1	66	43	0	110	52	2	3	0	57	11	133	1	0	145	330
08:30 AM	5	8	2	4	19	1	102	39	0	142	39	3	3	0	45	13	151	1	0	165	371
08:45 AM	4	7	4	4	19	1	96	36	0	133	37	1	4	0	42	14	127	3	1	145	339
Total	29	39	7	12	87	3	370	171	1	545	167	8	15	0	190	56	523	6	1	586	1408
Grand Total	61	86	14	21	182	5	645	351	2	1003	287	9	21	1	318	156	1020	9	4	1189	2692
Apprch %	33.5	47.3	7.7	11.5		0.5	64.3	35	0.2		90.3	2.8	6.6	0.3		13.1	85.8	0.8	0.3		
Total %	2.3	3.2	0.5	0.8	6.8	0.2	24	13	0.1	37.3	10.7	0.3	0.8	0	11.8	5.8	37.9	0.3	0.1	44.2	

Start Time	PALMER LN Southbound				MIDDLEFIELD RD Westbound				FAIR OAKS LN Northbound				MIDDLEFIELD RD Eastbound				Int. Total
	Right	Thru	Left	App. Total	Right	Thru	Left	App. Total	Right	Thru	Left	App. Total	Right	Thru	Left	App. Total	
Peak Hour Analysis From 07:00 AM to 08:45 AM - Peak 1 of 1																	
Peak Hour for Entire Intersection Begins at 07:30 AM																	
07:30 AM	9	16	1	26	0	79	54	133	43	0	0	43	20	159	0	179	381
07:45 AM	19	26	3	48	1	80	44	125	40	1	5	46	52	136	1	189	408
08:00 AM	13	15	1	29	0	106	53	159	39	2	5	46	18	112	1	131	365
08:15 AM	7	9	0	16	1	66	43	110	52	2	3	57	11	133	1	145	328
Total Volume	48	66	5	119	2	331	194	527	174	5	13	192	101	540	3	644	1482
% App. Total	40.3	55.5	4.2		0.4	62.8	36.8		90.6	2.6	6.8		15.7	83.9	0.5		
PHF	.632	.635	.417	.620	.500	.781	.898	.829	.837	.625	.650	.842	.486	.849	.750	.852	.908

Traffic Data Service

Campbell, CA
 (408) 377-2988
 tdsbay@cs.com

File Name : 3AM FINAL
 Site Code : 00000003
 Start Date : 9/24/2013
 Page No : 2

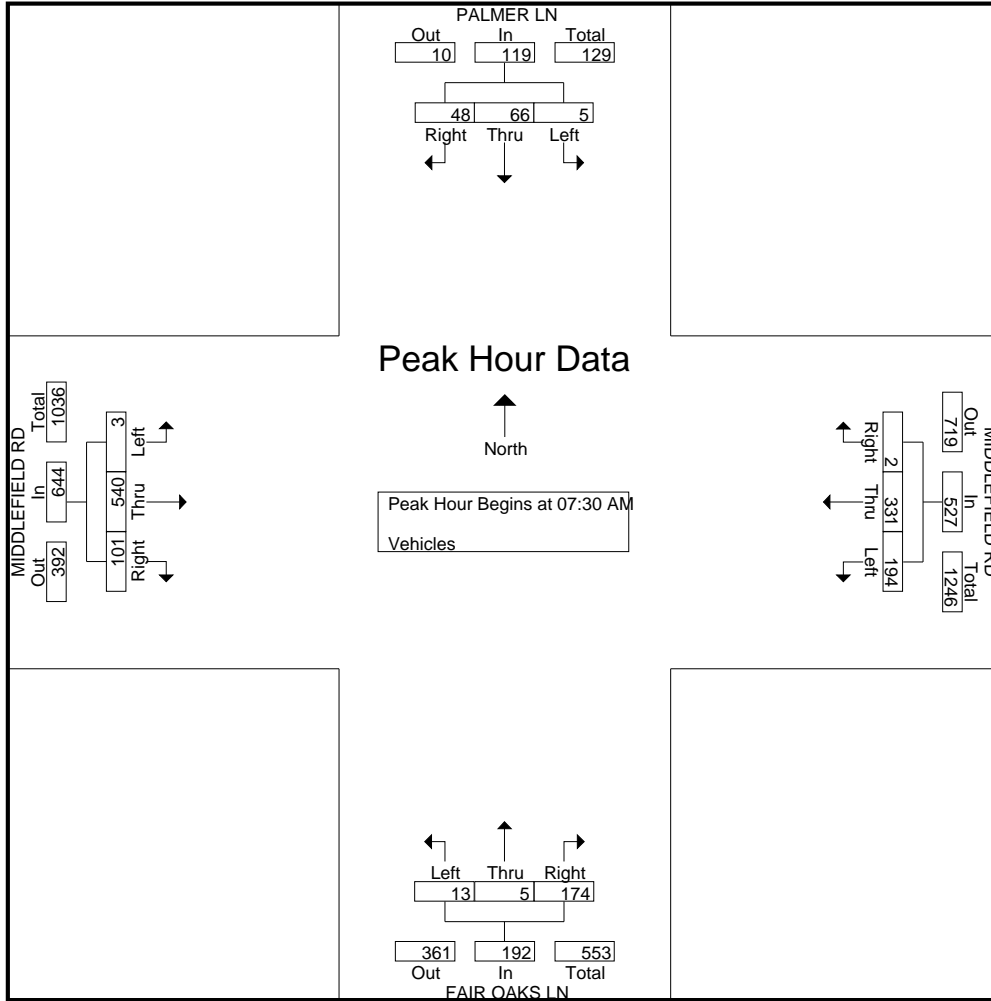

Traffic Data Service

Campbell, CA
 (408) 377-2988
 tdsbay@cs.com

File Name : 3AM FINAL
 Site Code : 00000003
 Start Date : 9/24/2013
 Page No : 1

Groups Printed- Bikes

Start Time	PALMER LN Southbound					MIDDLEFIELD RD Westbound					FAIR OAKS LN Northbound					MIDDLEFIELD RD Eastbound					Int. Total	
	Right	Thru	Left	Peds	App. Total	Right	Thru	Left	Peds	App. Total	Right	Thru	Left	Peds	App. Total	Right	Thru	Left	Peds	App. Total		
07:00 AM	1	0	0	0	1	0	1	0	0	1	0	0	0	0	0	0	5	0	0	0	5	7
07:15 AM	0	0	2	0	2	0	2	0	0	2	0	0	0	0	0	0	5	0	0	0	5	9
07:30 AM	0	0	1	0	1	0	3	0	0	3	1	0	0	0	1	0	4	0	0	0	4	9
07:45 AM	0	0	1	1	2	0	2	0	0	2	0	2	0	0	2	2	5	0	0	0	7	13
Total	1	0	4	1	6	0	8	0	0	8	1	2	0	0	3	2	19	0	0	0	21	38
08:00 AM	2	0	0	0	2	0	1	0	0	1	0	0	1	0	1	0	2	0	0	0	2	6
08:15 AM	0	0	0	0	0	0	0	0	0	0	1	0	0	0	1	0	12	0	0	0	12	13
08:30 AM	0	0	0	0	0	0	1	0	0	1	1	0	0	0	1	0	8	0	0	0	8	10
08:45 AM	0	0	1	0	1	2	4	0	0	6	1	0	0	0	1	0	3	0	0	0	3	11
Total	2	0	1	0	3	2	6	0	0	8	3	0	1	0	4	0	25	0	0	0	25	40
Grand Total	3	0	5	1	9	2	14	0	0	16	4	2	1	0	7	2	44	0	0	0	46	78
Apprch %	33.3	0	55.6	11.1		12.5	87.5	0	0		57.1	28.6	14.3	0		4.3	95.7	0	0	0		
Total %	3.8	0	6.4	1.3	11.5	2.6	17.9	0	0	20.5	5.1	2.6	1.3	0	9	2.6	56.4	0	0	0	59	

Start Time	PALMER LN Southbound				MIDDLEFIELD RD Westbound				FAIR OAKS LN Northbound				MIDDLEFIELD RD Eastbound				Int. Total
	Right	Thru	Left	App. Total	Right	Thru	Left	App. Total	Right	Thru	Left	App. Total	Right	Thru	Left	App. Total	
07:45 AM	0	0	1	1	0	2	0	2	0	2	0	2	2	5	0	7	12
08:00 AM	2	0	0	2	0	1	0	1	0	0	1	1	0	2	0	2	6
08:15 AM	0	0	0	0	0	0	0	0	1	0	0	1	0	12	0	12	13
08:30 AM	0	0	0	0	0	1	0	1	1	0	0	1	0	8	0	8	10
Total Volume	2	0	1	3	0	4	0	4	2	2	1	5	2	27	0	29	41
% App. Total	66.7	0	33.3		0	100	0		40	40	20		6.9	93.1	0		
PHF	.250	.000	.250	.375	.000	.500	.000	.500	.500	.250	.250	.625	.250	.563	.000	.604	.788

Peak Hour Analysis From 07:00 AM to 08:45 AM - Peak 1 of 1

Peak Hour for Entire Intersection Begins at 07:45 AM

Traffic Data Service

Campbell, CA
(408) 377-2988
tdsbay@cs.com

File Name : 3AM FINAL
Site Code : 00000003
Start Date : 9/24/2013
Page No : 2

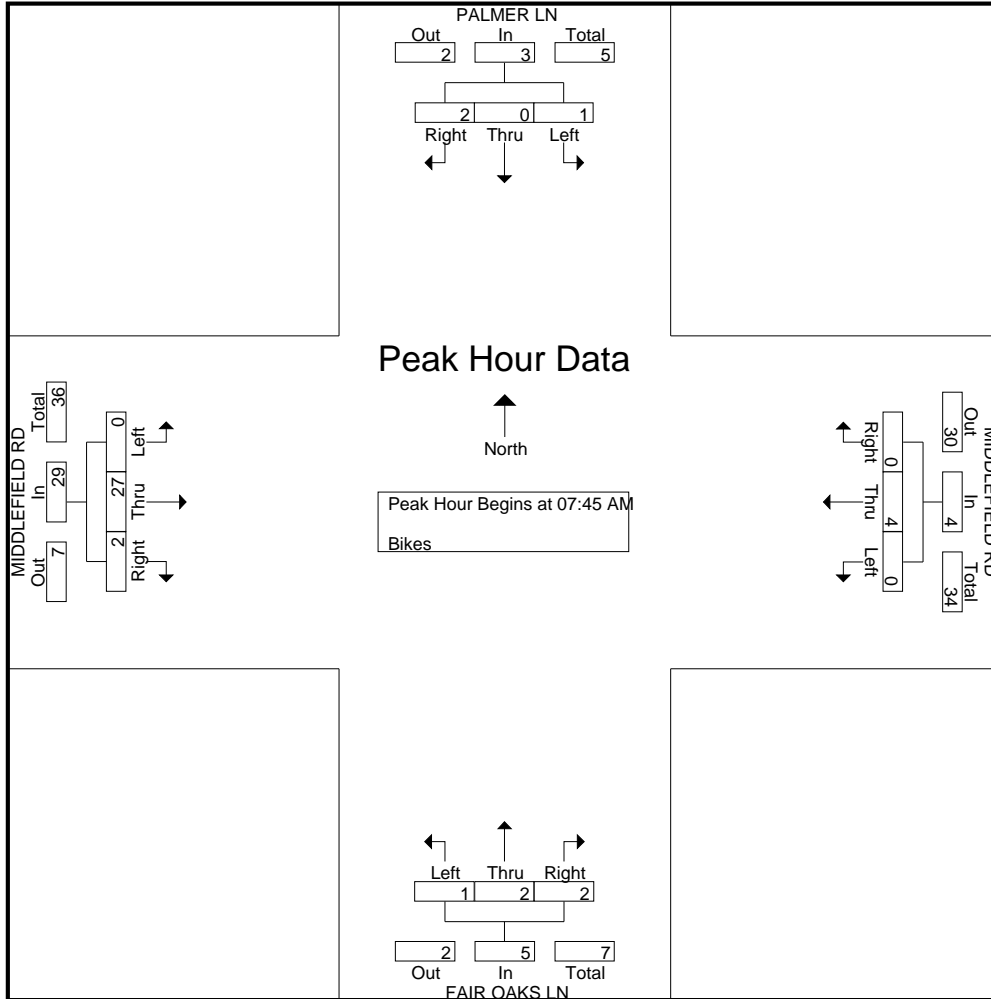

Traffic Data Service

Campbell, CA
 (408) 377-2988
 tdsbay@cs.com

File Name : 3PM FINAL
 Site Code : 00000003
 Start Date : 9/24/2013
 Page No : 1

Groups Printed- Vehicles

Start Time	PALMER LN Southbound					MIDDLEFIELD RD Westbound					FAIR OAKS LN Northbound					MIDDLEFIELD RD Eastbound					Int. Total
	Right	Thru	Left	Peds	App. Total	Right	Thru	Left	Peds	App. Total	Right	Thru	Left	Peds	App. Total	Right	Thru	Left	Peds	App. Total	
04:00 PM	5	0	1	1	7	3	161	32	0	196	52	6	10	0	68	7	93	5	0	105	376
04:15 PM	3	0	3	1	7	3	170	30	0	203	47	6	2	1	56	8	123	2	0	133	399
04:30 PM	1	0	0	1	2	1	151	32	0	184	43	3	9	1	56	6	130	4	0	140	382
04:45 PM	5	1	0	2	8	4	178	41	0	223	38	5	9	0	52	4	137	2	0	143	426
Total	14	1	4	5	24	11	660	135	0	806	180	20	30	2	232	25	483	13	0	521	1583
05:00 PM	2	3	0	1	6	4	163	51	0	218	30	2	10	0	42	12	154	3	0	169	435
05:15 PM	3	2	0	0	5	3	180	37	0	220	23	1	4	0	28	9	119	0	0	128	381
05:30 PM	4	1	0	0	5	3	182	51	0	236	31	5	5	0	41	9	128	5	0	142	424
05:45 PM	0	0	0	0	0	4	156	35	0	195	32	2	5	1	40	4	126	7	0	137	372
Total	9	6	0	1	16	14	681	174	0	869	116	10	24	1	151	34	527	15	0	576	1612
Grand Total	23	7	4	6	40	25	1341	309	0	1675	296	30	54	3	383	59	1010	28	0	1097	3195
Apprch %	57.5	17.5	10	15		1.5	80.1	18.4	0		77.3	7.8	14.1	0.8		5.4	92.1	2.6	0		
Total %	0.7	0.2	0.1	0.2	1.3	0.8	42	9.7	0	52.4	9.3	0.9	1.7	0.1	12	1.8	31.6	0.9	0	34.3	

Start Time	PALMER LN Southbound					MIDDLEFIELD RD Westbound					FAIR OAKS LN Northbound					MIDDLEFIELD RD Eastbound					Int. Total
	Right	Thru	Left	Peds	App. Total	Right	Thru	Left	Peds	App. Total	Right	Thru	Left	Peds	App. Total	Right	Thru	Left	Peds	App. Total	
04:45 PM	5	1	0	0	6	4	178	41	0	223	38	5	9	0	52	4	137	2	0	143	424
05:00 PM	2	3	0	0	5	4	163	51	0	218	30	2	10	0	42	12	154	3	0	169	434
05:15 PM	3	2	0	0	5	3	180	37	0	220	23	1	4	0	28	9	119	0	0	128	381
05:30 PM	4	1	0	0	5	3	182	51	0	236	31	5	5	0	41	9	128	5	0	142	424
Total Volume	14	7	0	0	21	14	703	180	0	897	122	13	28	0	163	34	538	10	0	582	1663
% App. Total	66.7	33.3	0	0		1.6	78.4	20.1	0		74.8	8	17.2	0		5.8	92.4	1.7	0		
PHF	.700	.583	.000	.000	.875	.875	.966	.882	.950		.803	.650	.700	.784		.708	.873	.500	.861		.958

Peak Hour Analysis From 04:00 PM to 05:45 PM - Peak 1 of 1

Peak Hour for Entire Intersection Begins at 04:45 PM

Traffic Data Service

Campbell, CA
 (408) 377-2988
 tdsbay@cs.com

File Name : 3PM FINAL
 Site Code : 00000003
 Start Date : 9/24/2013
 Page No : 2

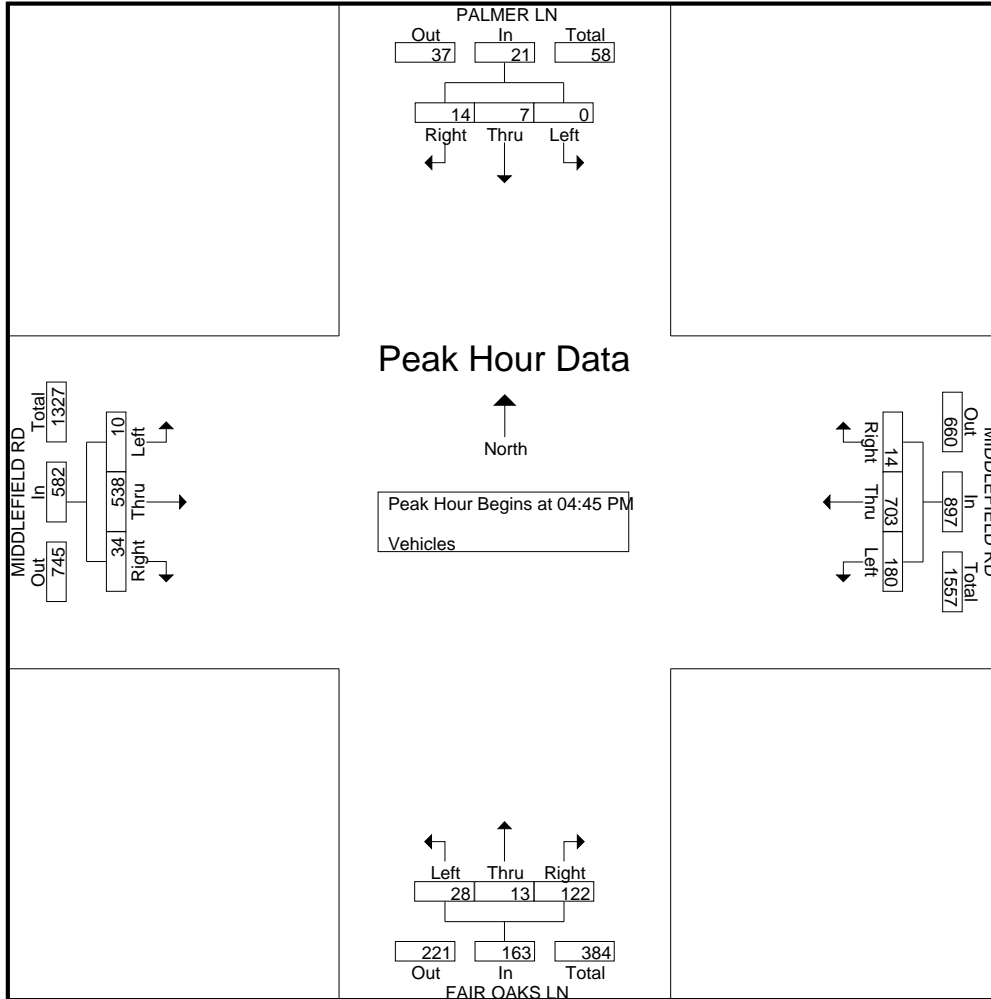

Traffic Data Service

Campbell, CA
 (408) 377-2988
 tdsbay@cs.com

File Name : 3PM FINAL
 Site Code : 00000003
 Start Date : 9/24/2013
 Page No : 1

Groups Printed- Bikes

Start Time	PALMER LN Southbound					MIDDLEFIELD RD Westbound					FAIR OAKS LN Northbound					MIDDLEFIELD RD Eastbound					Int. Total
	Right	Thru	Left	Peds	App. Total	Right	Thru	Left	Peds	App. Total	Right	Thru	Left	Peds	App. Total	Right	Thru	Left	Peds	App. Total	
04:00 PM	0	0	0	0	0	0	2	1	0	3	0	0	0	0	0	0	0	0	0	0	3
04:15 PM	0	0	0	0	0	0	1	0	0	1	0	0	0	0	0	0	2	0	0	0	3
04:30 PM	0	0	0	0	0	1	1	0	0	2	0	0	0	0	0	0	4	0	0	0	6
04:45 PM	0	0	0	0	0	2	0	0	0	2	0	0	0	0	0	2	0	0	0	0	4
Total	0	0	0	0	0	3	4	1	0	8	0	0	0	0	0	2	6	0	0	0	16
05:00 PM	0	0	0	0	0	0	0	0	0	0	0	0	0	0	0	0	1	0	0	1	1
05:15 PM	0	2	0	0	2	0	0	2	0	2	0	0	0	0	0	0	1	0	0	1	5
05:30 PM	0	1	0	0	1	0	0	0	0	0	0	0	1	0	1	1	2	0	0	3	5
05:45 PM	0	1	0	0	1	0	0	1	0	1	0	0	0	0	0	2	5	0	0	7	9
Total	0	4	0	0	4	0	0	3	0	3	0	0	1	0	1	3	9	0	0	12	20
Grand Total	0	4	0	0	4	3	4	4	0	11	0	0	1	0	1	5	15	0	0	20	36
Apprch %	0	100	0	0		27.3	36.4	36.4	0		0	0	100	0		25	75	0	0		
Total %	0	11.1	0	0	11.1	8.3	11.1	11.1	0	30.6	0	0	2.8	0	2.8	13.9	41.7	0	0	55.6	

Start Time	PALMER LN Southbound				MIDDLEFIELD RD Westbound				FAIR OAKS LN Northbound				MIDDLEFIELD RD Eastbound				Int. Total
	Right	Thru	Left	App. Total	Right	Thru	Left	App. Total	Right	Thru	Left	App. Total	Right	Thru	Left	App. Total	
05:00 PM	0	0	0	0	0	0	0	0	0	0	0	0	0	1	0	1	1
05:15 PM	0	2	0	2	0	0	2	2	0	0	0	0	0	1	0	1	5
05:30 PM	0	1	0	1	0	0	0	0	0	0	1	1	1	2	0	3	5
05:45 PM	0	1	0	1	0	0	1	1	0	0	0	0	2	5	0	7	9
Total Volume	0	4	0	4	0	0	3	3	0	0	1	1	3	9	0	12	20
% App. Total	0	100	0		0	0	100		0	0	100		25	75	0		
PHF	.000	.500	.000	.500	.000	.000	.375	.375	.000	.000	.250	.250	.375	.450	.000	.429	.556

Peak Hour Analysis From 04:00 PM to 05:45 PM - Peak 1 of 1

Peak Hour for Entire Intersection Begins at 05:00 PM

Traffic Data Service

Campbell, CA

(408) 377-2988

tdsbay@cs.com

File Name : 3PM FINAL

Site Code : 00000003

Start Date : 9/24/2013

Page No : 2

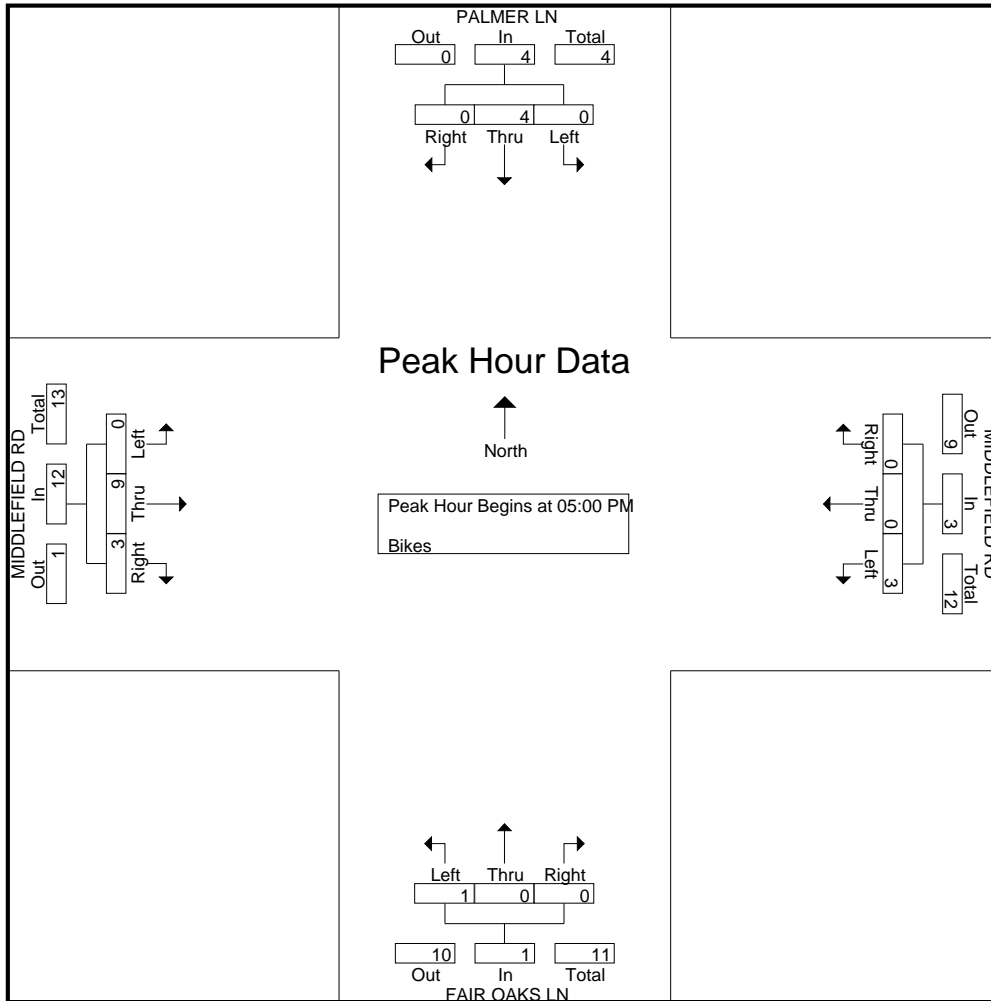

Traffic Data Service

Campbell, CA
 (408) 377-2988
 tdsbay@cs.com

File Name : 13AM FINAL
 Site Code : 00000013
 Start Date : 5/22/2013
 Page No : 1

Groups Printed- Vehicles

Start Time	PERRY ST Southbound					BROADWAY Westbound					CALIFORNIA ST Northbound					BROADWAY Eastbound					Int. Total
	Right	Thru	Left	Peds	App. Total	Right	Thru	Left	Peds	App. Total	Right	Thru	Left	Peds	App. Total	Right	Thru	Left	Peds	App. Total	
07:00 AM	2	3	1	8	14	3	13	9	3	28	3	5	1	17	26	7	26	7	16	56	124
07:15 AM	0	3	1	5	9	3	16	10	0	29	7	4	0	22	33	11	44	2	25	82	153
07:30 AM	7	3	0	4	14	2	23	8	1	34	7	4	0	13	24	4	45	3	16	68	140
07:45 AM	1	4	2	15	22	5	35	17	3	60	6	2	1	18	27	7	57	0	24	88	197
Total	10	13	4	32	59	13	87	44	7	151	23	15	2	70	110	29	172	12	81	294	614
08:00 AM	1	1	4	10	16	3	16	18	4	41	16	4	1	49	70	13	91	9	40	153	280
08:15 AM	3	4	5	7	19	8	41	10	4	63	12	6	1	54	73	12	79	5	38	134	289
08:30 AM	4	3	5	28	40	6	36	7	2	51	18	5	1	34	58	8	79	9	44	140	289
08:45 AM	2	4	5	14	25	4	26	7	1	38	10	2	1	22	35	14	67	4	24	109	207
Total	10	12	19	59	100	21	119	42	11	193	56	17	4	159	236	47	316	27	146	536	1065
Grand Total	20	25	23	91	159	34	206	86	18	344	79	32	6	229	346	76	488	39	227	830	1679
Apprch %	12.6	15.7	14.5	57.2		9.9	59.9	25	5.2		22.8	9.2	1.7	66.2		9.2	58.8	4.7	27.3		
Total %	1.2	1.5	1.4	5.4	9.5	2	12.3	5.1	1.1	20.5	4.7	1.9	0.4	13.6	20.6	4.5	29.1	2.3	13.5	49.4	

Start Time	PERRY ST Southbound				BROADWAY Westbound				CALIFORNIA ST Northbound				BROADWAY Eastbound				Int. Total
	Right	Thru	Left	App. Total	Right	Thru	Left	App. Total	Right	Thru	Left	App. Total	Right	Thru	Left	App. Total	
08:00 AM	1	1	4	6	3	16	18	37	16	4	1	21	13	91	9	113	177
08:15 AM	3	4	5	12	8	41	10	59	12	6	1	19	12	79	5	96	186
08:30 AM	4	3	5	12	6	36	7	49	18	5	1	24	8	79	9	96	181
08:45 AM	2	4	5	11	4	26	7	37	10	2	1	13	14	67	4	85	146
Total Volume	10	12	19	41	21	119	42	182	56	17	4	77	47	316	27	390	690
% App. Total	24.4	29.3	46.3		11.5	65.4	23.1		72.7	22.1	5.2		12.1	81	6.9		
PHF	.625	.750	.950	.854	.656	.726	.583	.771	.778	.708	1.00	.802	.839	.868	.750	.863	.927

Peak Hour Analysis From 07:00 AM to 08:45 AM - Peak 1 of 1

Peak Hour for Entire Intersection Begins at 08:00 AM

Traffic Data Service

Campbell, CA
(408) 377-2988
tdsbay@cs.com

File Name : 13AM FINAL
Site Code : 00000013
Start Date : 5/22/2013
Page No : 2

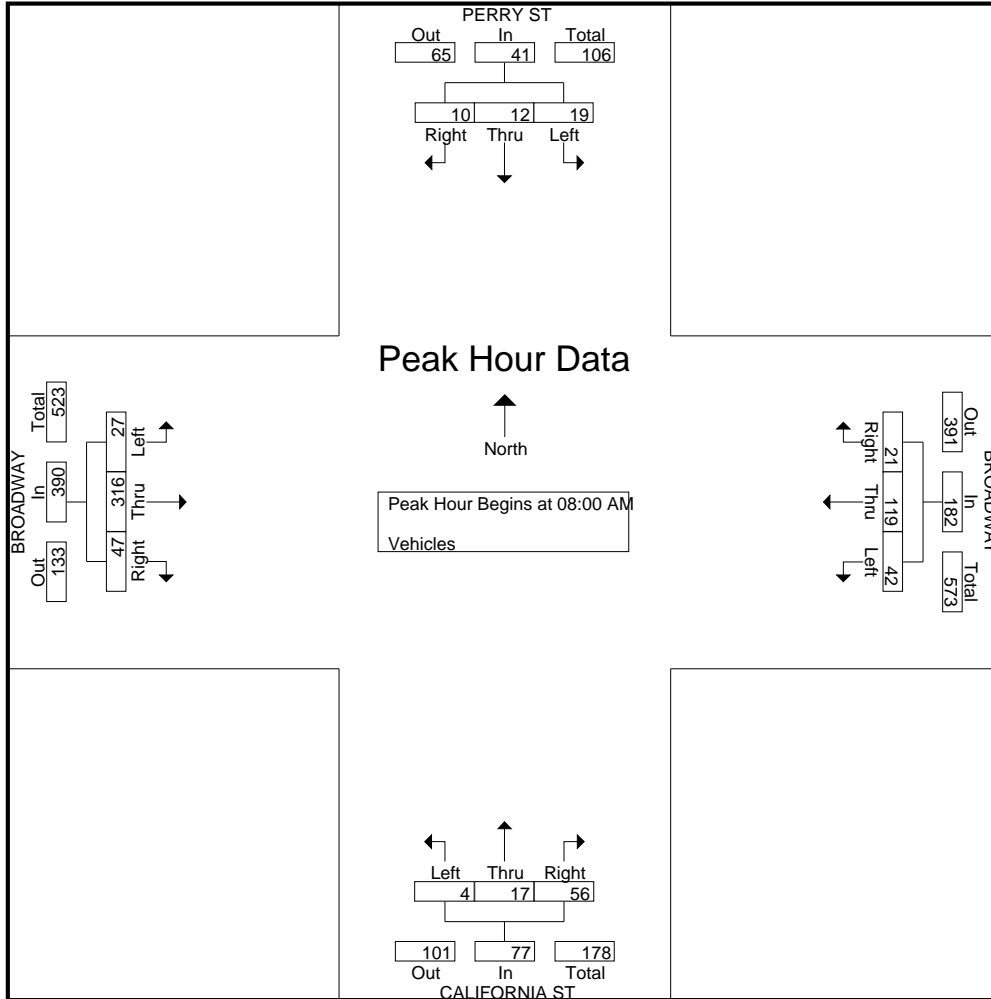

Traffic Data Service

Campbell, CA
 (408) 377-2988
 tdsbay@cs.com

File Name : 13AM FINAL
 Site Code : 00000013
 Start Date : 5/22/2013
 Page No : 1

Groups Printed- Bikes

Start Time	PERRY ST Southbound					BROADWAY Westbound					CALIFORNIA ST Northbound					BROADWAY Eastbound					Int. Total
	Right	Thru	Left	Peds	App. Total	Right	Thru	Left	Peds	App. Total	Right	Thru	Left	Peds	App. Total	Right	Thru	Left	Peds	App. Total	
07:00 AM	0	0	0	0	0	1	0	0	0	1	1	0	0	0	1	0	3	1	0	4	6
07:15 AM	0	0	2	0	2	1	0	0	0	1	0	0	0	0	0	0	1	0	0	1	4
07:30 AM	0	0	1	0	1	0	0	0	0	0	1	0	0	0	1	0	4	0	0	4	6
07:45 AM	0	0	1	0	1	0	1	1	0	2	0	1	0	0	1	0	1	0	0	1	5
Total	0	0	4	0	4	2	1	1	0	4	2	1	0	0	3	0	9	1	0	10	21
08:00 AM	0	1	0	0	1	1	0	0	0	1	0	0	0	0	0	0	2	0	0	2	4
08:15 AM	0	0	0	0	0	0	1	0	0	1	0	0	0	0	0	0	3	0	0	3	4
08:30 AM	0	0	3	0	3	0	0	0	0	0	0	0	0	0	0	0	4	0	0	4	7
08:45 AM	0	0	0	0	0	0	0	0	0	0	0	0	0	0	0	0	1	0	0	1	1
Total	0	1	3	0	4	1	1	0	0	2	0	0	0	0	0	0	10	0	0	10	16
Grand Total	0	1	7	0	8	3	2	1	0	6	2	1	0	0	3	0	19	1	0	20	37
Apprch %	0	12.5	87.5	0		50	33.3	16.7	0		66.7	33.3	0	0		0	95	5	0		
Total %	0	2.7	18.9	0	21.6	8.1	5.4	2.7	0	16.2	5.4	2.7	0	0	8.1	0	51.4	2.7	0	54.1	

Start Time	PERRY ST Southbound				BROADWAY Westbound				CALIFORNIA ST Northbound				BROADWAY Eastbound				Int. Total
	Right	Thru	Left	App. Total	Right	Thru	Left	App. Total	Right	Thru	Left	App. Total	Right	Thru	Left	App. Total	
07:00 AM	0	0	0	0	1	0	0	1	1	0	0	1	0	3	1	4	6
07:15 AM	0	0	2	2	1	0	0	1	0	0	0	0	0	1	0	1	4
07:30 AM	0	0	1	1	0	0	0	0	1	0	0	1	0	4	0	4	6
07:45 AM	0	0	1	1	0	1	1	2	0	1	0	1	0	1	0	1	5
Total Volume	0	0	4	4	2	1	1	4	2	1	0	3	0	9	1	10	21
% App. Total	0	0	100		50	25	25		66.7	33.3	0		0	90	10		
PHF	.000	.000	.500	.500	.500	.250	.250	.500	.500	.250	.000	.750	.000	.563	.250	.625	.875

Peak Hour Analysis From 07:00 AM to 08:45 AM - Peak 1 of 1

Peak Hour for Entire Intersection Begins at 07:00 AM

Traffic Data Service

Campbell, CA
(408) 377-2988
tdsbay@cs.com

File Name : 13AM FINAL
Site Code : 00000013
Start Date : 5/22/2013
Page No : 2

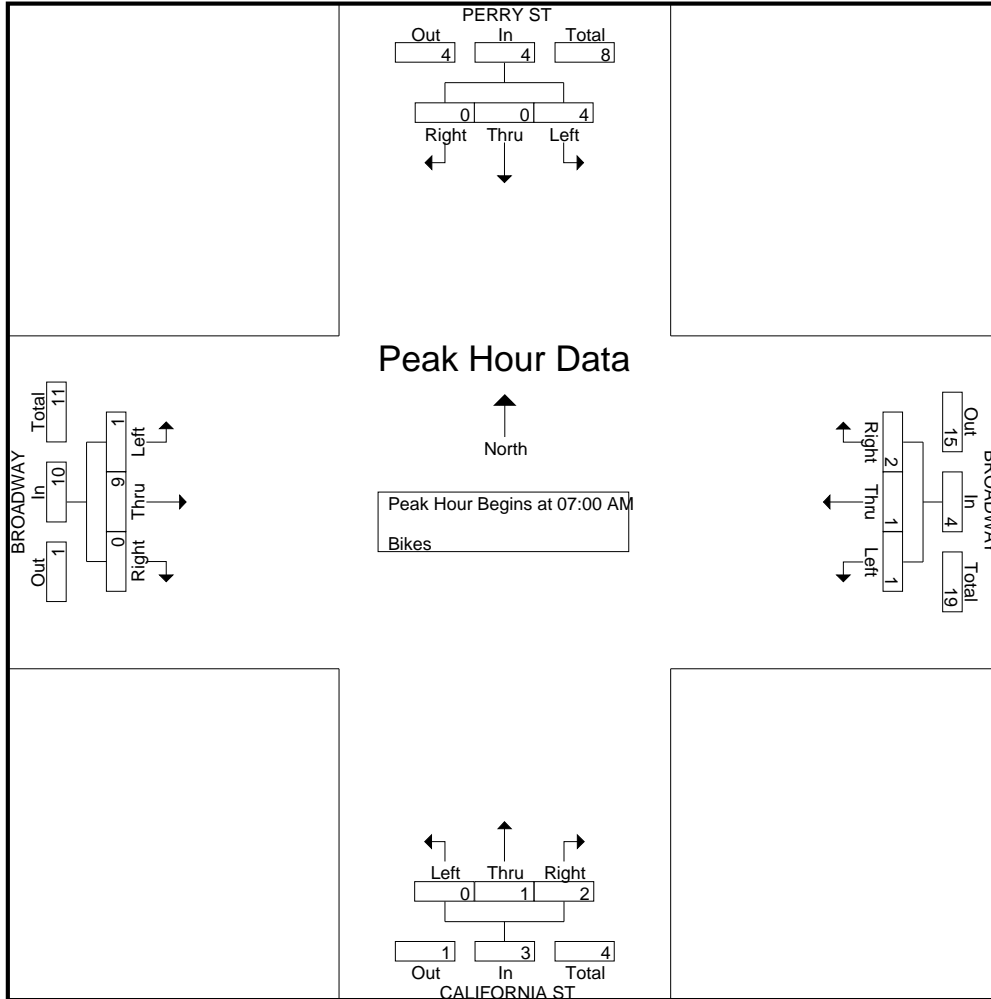

Traffic Data Service

Campbell, CA
 (408) 377-2988
 tdsbay@cs.com

File Name : 13PM FINAL
 Site Code : 00000013
 Start Date : 5/22/2013
 Page No : 1

Groups Printed- Vehicles

Start Time	PERRY ST Southbound					BROADWAY Westbound					CALIFORNIA ST Northbound					BROADWAY Eastbound					Int. Total
	Right	Thru	Left	Peds	App. Total	Right	Thru	Left	Peds	App. Total	Right	Thru	Left	Peds	App. Total	Right	Thru	Left	Peds	App. Total	
04:00 PM	8	4	6	11	29	4	52	13	3	72	15	5	3	35	58	8	58	11	24	101	260
04:15 PM	10	2	4	2	18	3	75	13	5	96	11	6	4	21	42	9	48	5	19	81	237
04:30 PM	16	8	3	6	33	6	74	21	1	102	18	2	3	23	46	9	35	9	21	74	255
04:45 PM	10	5	8	5	28	15	74	22	3	114	15	6	4	33	58	15	38	6	40	99	299
Total	44	19	21	24	108	28	275	69	12	384	59	19	14	112	204	41	179	31	104	355	1051
05:00 PM	13	5	5	10	33	8	93	25	3	129	17	6	2	36	61	6	38	2	32	78	301
05:15 PM	12	4	5	6	27	7	78	28	0	113	15	3	5	44	67	11	32	9	36	88	295
05:30 PM	20	4	6	11	41	16	71	21	7	115	14	6	2	47	69	12	44	5	32	93	318
05:45 PM	9	15	5	10	39	8	69	20	3	100	13	8	3	18	42	15	42	12	20	89	270
Total	54	28	21	37	140	39	311	94	13	457	59	23	12	145	239	44	156	28	120	348	1184
Grand Total	98	47	42	61	248	67	586	163	25	841	118	42	26	257	443	85	335	59	224	703	2235
Apprch %	39.5	19	16.9	24.6		8	69.7	19.4	3		26.6	9.5	5.9	58		12.1	47.7	8.4	31.9		
Total %	4.4	2.1	1.9	2.7	11.1	3	26.2	7.3	1.1	37.6	5.3	1.9	1.2	11.5	19.8	3.8	15	2.6	10	31.5	

Start Time	PERRY ST Southbound				BROADWAY Westbound				CALIFORNIA ST Northbound				BROADWAY Eastbound				Int. Total
	Right	Thru	Left	App. Total	Right	Thru	Left	App. Total	Right	Thru	Left	App. Total	Right	Thru	Left	App. Total	
Peak Hour Analysis From 04:00 PM to 05:45 PM - Peak 1 of 1																	
Peak Hour for Entire Intersection Begins at 05:00 PM																	
05:00 PM	13	5	5	23	8	93	25	126	17	6	2	25	6	38	2	46	220
05:15 PM	12	4	5	21	7	78	28	113	15	3	5	23	11	32	9	52	209
05:30 PM	20	4	6	30	16	71	21	108	14	6	2	22	12	44	5	61	221
05:45 PM	9	15	5	29	8	69	20	97	13	8	3	24	15	42	12	69	219
Total Volume	54	28	21	103	39	311	94	444	59	23	12	94	44	156	28	228	869
% App. Total	52.4	27.2	20.4		8.8	70	21.2		62.8	24.5	12.8		19.3	68.4	12.3		
PHF	.675	.467	.875	.858	.609	.836	.839	.881	.868	.719	.600	.940	.733	.886	.583	.826	.983

Traffic Data Service

Campbell, CA
(408) 377-2988
tdsbay@cs.com

File Name : 13PM FINAL
Site Code : 00000013
Start Date : 5/22/2013
Page No : 2

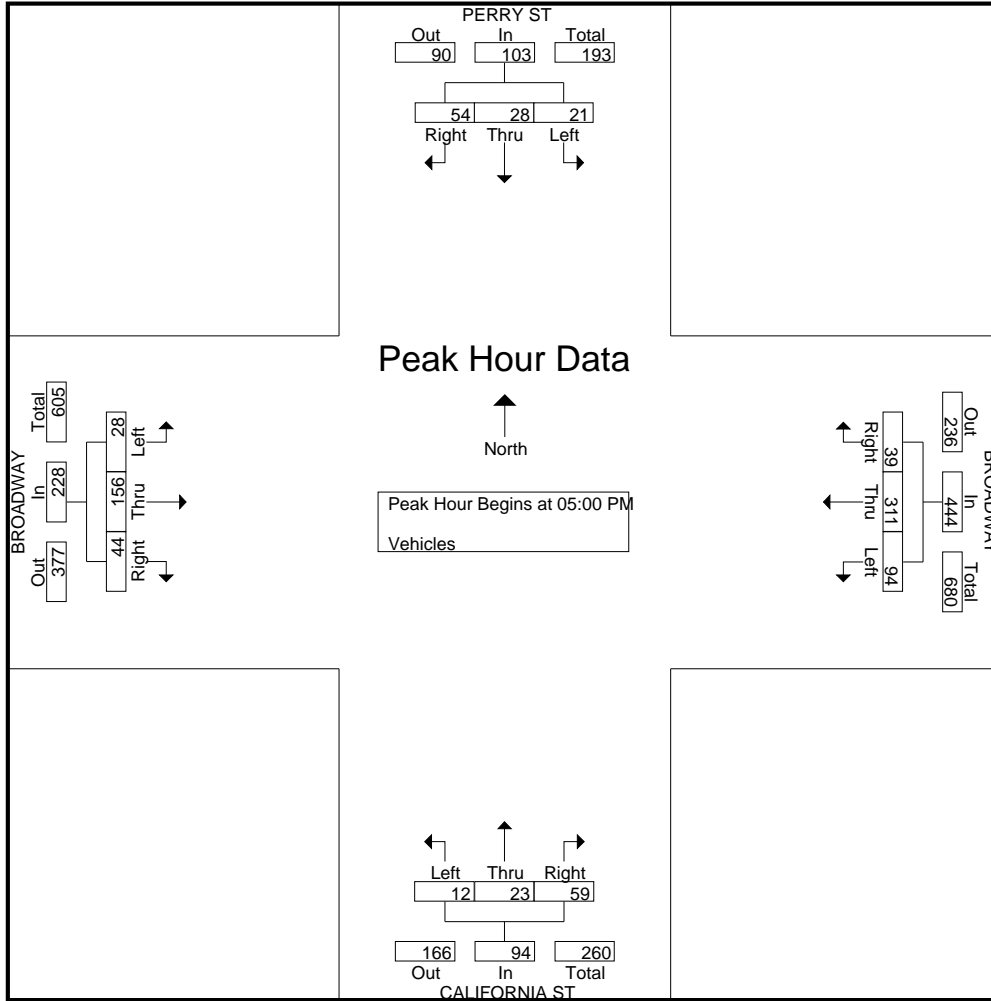

Traffic Data Service

Campbell, CA
 (408) 377-2988
 tdsbay@cs.com

File Name : 13PM FINAL
 Site Code : 00000013
 Start Date : 5/22/2013
 Page No : 1

Groups Printed- Bikes

Start Time	PERRY ST Southbound					BROADWAY Westbound					CALIFORNIA ST Northbound					BROADWAY Eastbound					Int. Total
	Right	Thru	Left	Peds	App. Total	Right	Thru	Left	Peds	App. Total	Right	Thru	Left	Peds	App. Total	Right	Thru	Left	Peds	App. Total	
04:00 PM	0	0	0	0	0	0	1	0	0	1	0	1	0	0	1	1	0	0	0	1	3
04:15 PM	0	0	0	0	0	0	0	0	1	1	0	0	1	0	1	0	2	0	0	2	4
04:30 PM	0	0	0	0	0	0	1	2	0	3	0	0	0	0	0	2	0	0	0	2	5
04:45 PM	0	1	1	0	2	2	1	0	0	3	1	0	0	0	1	1	3	0	0	4	10
Total	0	1	1	0	2	2	3	2	1	8	1	1	1	0	3	4	5	0	0	9	22
05:00 PM	0	0	0	0	0	0	2	0	0	2	0	0	0	0	0	0	1	0	0	1	3
05:15 PM	0	0	0	0	0	1	1	1	0	3	0	0	0	0	0	0	0	0	0	0	3
05:30 PM	0	0	0	0	0	1	4	2	0	7	0	1	0	0	1	0	0	0	0	0	8
05:45 PM	0	0	0	0	0	2	3	0	0	5	0	0	0	0	0	0	1	0	0	1	6
Total	0	0	0	0	0	4	10	3	0	17	0	1	0	0	1	0	2	0	0	2	20
Grand Total	0	1	1	0	2	6	13	5	1	25	1	2	1	0	4	4	7	0	0	11	42
Apprch %	0	50	50	0		24	52	20	4		25	50	25	0		36.4	63.6	0	0		
Total %	0	2.4	2.4	0	4.8	14.3	31	11.9	2.4	59.5	2.4	4.8	2.4	0	9.5	9.5	16.7	0	0	26.2	

Start Time	PERRY ST Southbound				BROADWAY Westbound				CALIFORNIA ST Northbound				BROADWAY Eastbound				Int. Total
	Right	Thru	Left	App. Total	Right	Thru	Left	App. Total	Right	Thru	Left	App. Total	Right	Thru	Left	App. Total	
04:45 PM	0	1	1	2	2	1	0	3	1	0	0	1	1	3	0	4	10
05:00 PM	0	0	0	0	0	2	0	2	0	0	0	0	0	1	0	1	3
05:15 PM	0	0	0	0	1	1	1	3	0	0	0	0	0	0	0	0	3
05:30 PM	0	0	0	0	1	4	2	7	0	1	0	1	0	0	0	0	8
Total Volume	0	1	1	2	4	8	3	15	1	1	0	2	1	4	0	5	24
% App. Total	0	50	50		26.7	53.3	20		50	50	0		20	80	0		
PHF	.000	.250	.250	.250	.500	.500	.375	.536	.250	.250	.000	.500	.250	.333	.000	.313	.600

Peak Hour Analysis From 04:00 PM to 05:45 PM - Peak 1 of 1

Peak Hour for Entire Intersection Begins at 04:45 PM

Traffic Data Service

Campbell, CA

(408) 377-2988

tdsbay@cs.com

File Name : 13PM FINAL

Site Code : 00000013

Start Date : 5/22/2013

Page No : 2

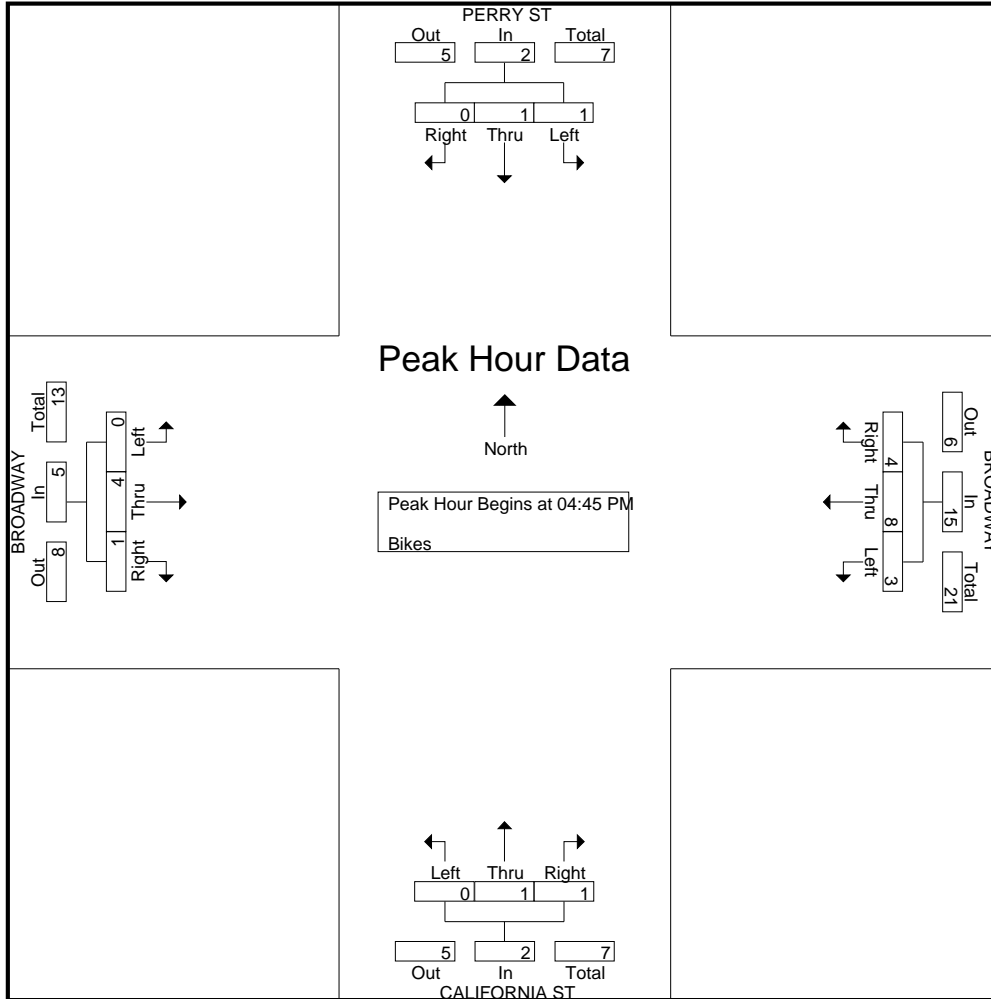

fp

Groups Printed- Vehicles Only

Start Time	EL CAMINO REAL Southbound				WHIPPLE AV Westbound				EL CAMINO REAL Northbound				WHIPPLE AV Eastbound				Int. Total
	RT	TH	LT	App. Total	RT	TH	LT	App. Total	RT	TH	LT	App. Total	RT	TH	LT	App. Total	
07:00	5	105	26	136	32	41	52	125	49	92	2	143	5	52	9	66	470
07:15	9	136	38	183	28	58	62	148	61	111	7	179	5	61	18	84	594
07:30	11	158	46	215	36	73	79	188	83	153	6	242	10	85	24	119	764
07:45	16	226	62	304	51	69	85	205	96	216	11	323	14	97	36	147	979
Total	41	625	172	838	147	241	278	666	289	572	26	887	34	295	87	416	2807
08:00	19	205	89	313	58	62	74	194	137	223	21	381	9	111	24	144	1032
08:15	11	211	75	297	46	76	59	181	121	174	15	310	11	124	21	156	944
08:30	14	186	71	271	49	80	66	195	86	165	8	259	14	106	19	139	864
08:45	16	194	63	273	54	71	62	187	81	178	6	265	7	89	23	119	844
Total	60	796	298	1154	207	289	261	757	425	740	50	1215	41	430	87	558	3684
Grand Total	101	1421	470	1992	354	530	539	1423	714	1312	76	2102	75	725	174	974	6491
Apprch %	5.1	71.3	23.6		24.9	37.2	37.9		34	62.4	3.6		7.7	74.4	17.9		
Total %	1.6	21.9	7.2	30.7	5.5	8.2	8.3	21.9	11	20.2	1.2	32.4	1.2	11.2	2.7	15	

Start Time	EL CAMINO REAL Southbound				WHIPPLE AV Westbound				EL CAMINO REAL Northbound				WHIPPLE AV Eastbound				Int. Total
	RT	TH	LT	App. Total	RT	TH	LT	App. Total	RT	TH	LT	App. Total	RT	TH	LT	App. Total	
07:45	16	226	62	304	51	69	85	205	96	216	11	323	14	97	36	147	979
08:00	19	205	89	313	58	62	74	194	137	223	21	381	9	111	24	144	1032
08:15	11	211	75	297	46	76	59	181	121	174	15	310	11	124	21	156	944
08:30	14	186	71	271	49	80	66	195	86	165	8	259	14	106	19	139	864
Total Volume	60	828	297	1185	204	287	284	775	440	778	55	1273	48	438	100	586	3819
% App. Total	5.1	69.9	25.1		26.3	37	36.6		34.6	61.1	4.3		8.2	74.7	17.1		
PHF	.789	.916	.834	.946	.879	.897	.835	.945	.803	.872	.655	.835	.857	.883	.694	.939	.925

Peak Hour Analysis From 07:00 to 08:45 - Peak 1 of 1

Peak Hour for Entire Intersection Begins at 07:45

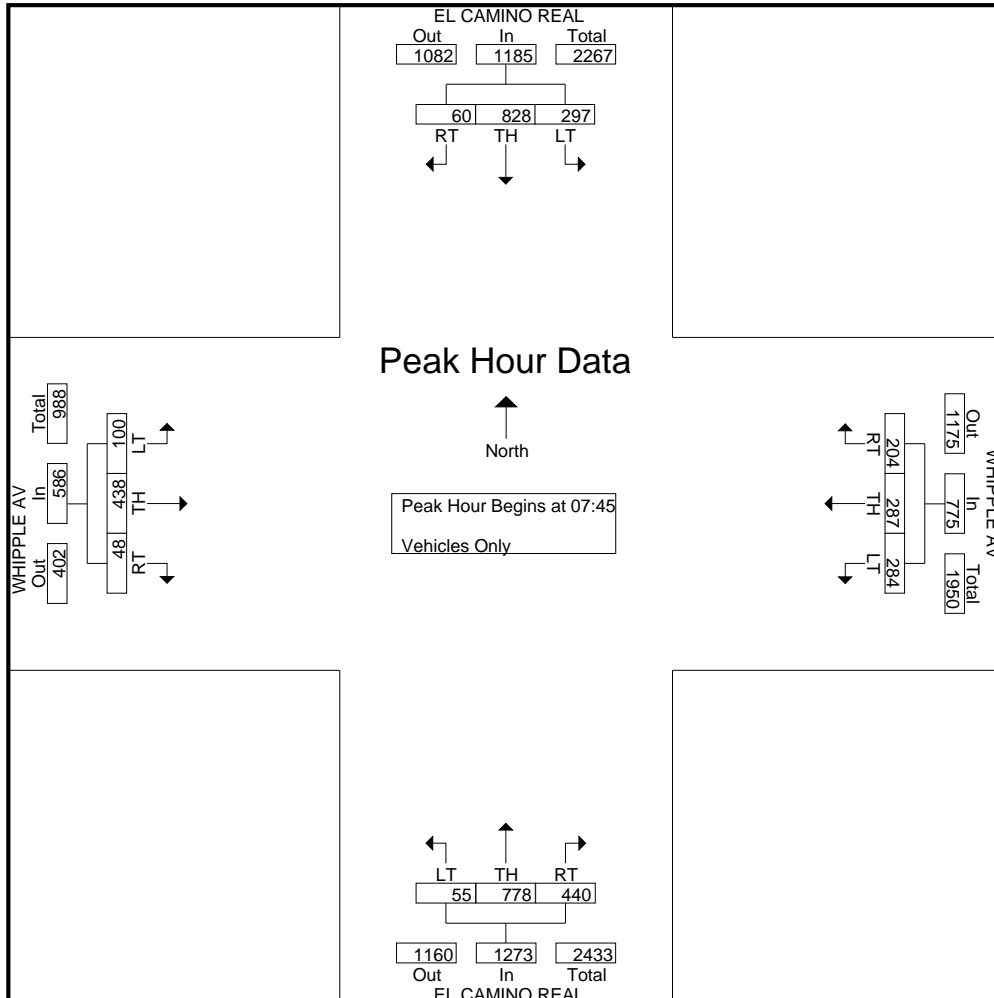

fp

Groups Printed- Vehicles Only

Start Time	EL CAMINO REAL Southbound				WHIPPLE AV Westbound				EL CAMINO REAL Northbound				WHIPPLE AV Eastbound				Int. Total
	RT	TH	LT	App. Total	RT	TH	LT	App. Total	RT	TH	LT	App. Total	RT	TH	LT	App. Total	
16:00	18	191	41	250	58	66	64	188	71	215	19	305	15	52	26	93	836
16:15	11	183	47	241	61	59	73	193	66	238	21	325	15	63	31	109	868
16:30	16	211	51	278	66	63	76	205	83	262	16	361	11	69	38	118	962
16:45	22	228	56	306	83	57	62	202	72	298	11	381	18	64	36	118	1007
Total	67	813	195	1075	268	245	275	788	292	1013	67	1372	59	248	131	438	3673
17:00	27	216	48	291	75	75	81	231	66	322	15	403	11	51	29	91	1016
17:15	25	231	53	309	72	93	93	258	58	305	9	372	13	58	30	101	1040
17:30	21	205	42	268	86	98	68	252	62	309	13	384	12	49	26	87	991
17:45	16	194	46	256	90	81	57	228	64	283	8	355	14	54	27	95	934
Total	89	846	189	1124	323	347	299	969	250	1219	45	1514	50	212	112	374	3981
Grand Total	156	1659	384	2199	591	592	574	1757	542	2232	112	2886	109	460	243	812	7654
Approch %	7.1	75.4	17.5		33.6	33.7	32.7		18.8	77.3	3.9		13.4	56.7	29.9		
Total %	2	21.7	5	28.7	7.7	7.7	7.5	23	7.1	29.2	1.5	37.7	1.4	6	3.2	10.6	

Start Time	EL CAMINO REAL Southbound				WHIPPLE AV Westbound				EL CAMINO REAL Northbound				WHIPPLE AV Eastbound				Int. Total
	RT	TH	LT	App. Total	RT	TH	LT	App. Total	RT	TH	LT	App. Total	RT	TH	LT	App. Total	
16:45	22	228	56	306	83	57	62	202	72	298	11	381	18	64	36	118	1007
17:00	27	216	48	291	75	75	81	231	66	322	15	403	11	51	29	91	1016
17:15	25	231	53	309	72	93	93	258	58	305	9	372	13	58	30	101	1040
17:30	21	205	42	268	86	98	68	252	62	309	13	384	12	49	26	87	991
Total Volume	95	880	199	1174	316	323	304	943	258	1234	48	1540	54	222	121	397	4054
% App. Total	8.1	75	17		33.5	34.3	32.2		16.8	80.1	3.1		13.6	55.9	30.5		
PHF	.880	.952	.888	.950	.919	.824	.817	.914	.896	.958	.800	.955	.750	.867	.840	.841	.975

Peak Hour Analysis From 16:00 to 17:45 - Peak 1 of 1

Peak Hour for Entire Intersection Begins at 16:45

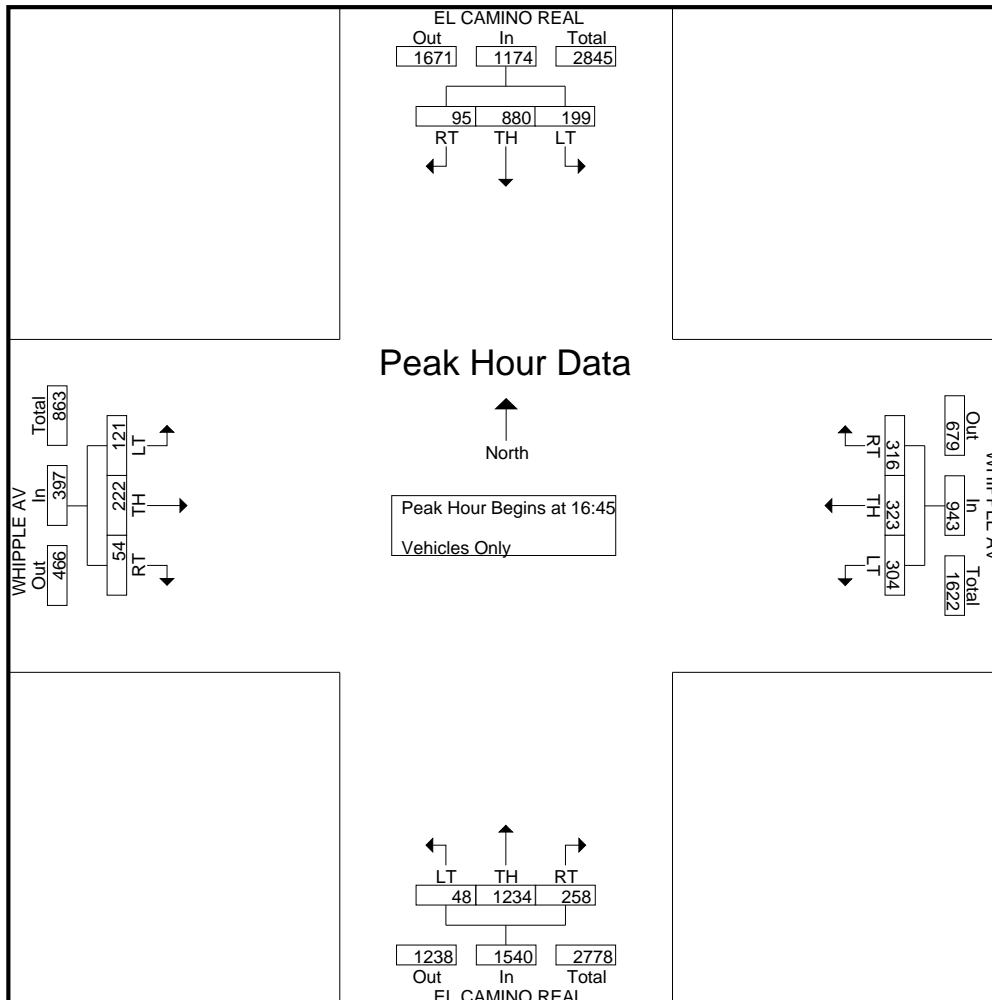

Traffic Data Service

Campbell, CA
 (408) 377-2988
 tdsbay@cs.com

File Name : 64AM FINAL
 Site Code : 00000064
 Start Date : 6/6/2013
 Page No : 1

Groups Printed- Vehicles

Start Time	ARGUELLO ST Southbound					BREWSTER AVE Westbound					ARGUELLO ST Northbound					BREWSTER AVE Eastbound					Int. Total
	Right	Thru	Left	Peds	App. Total	Right	Thru	Left	Peds	App. Total	Right	Thru	Left	Peds	App. Total	Right	Thru	Left	Peds	App. Total	
07:00 AM	10	12	3	1	26	0	15	3	2	20	2	12	2	0	16	5	50	12	2	69	131
07:15 AM	24	10	4	1	39	2	23	2	0	27	1	13	2	0	16	3	54	20	7	84	166
07:30 AM	20	7	5	3	35	0	26	5	1	32	0	12	1	1	14	4	67	10	2	83	164
07:45 AM	40	28	3	7	78	3	30	4	2	39	0	12	4	4	20	4	132	16	0	152	289
Total	94	57	15	12	178	5	94	14	5	118	3	49	9	5	66	16	303	58	11	388	750
08:00 AM	51	18	9	6	84	4	41	10	4	59	3	18	2	4	27	9	117	29	3	158	328
08:15 AM	25	33	11	1	70	5	39	5	3	52	2	10	3	0	15	8	119	10	3	140	277
08:30 AM	18	18	13	3	52	0	29	4	2	35	1	22	2	3	28	20	129	23	1	173	288
08:45 AM	19	22	5	5	51	6	39	5	2	52	2	14	7	6	29	12	86	18	2	118	250
Total	113	91	38	15	257	15	148	24	11	198	8	64	14	13	99	49	451	80	9	589	1143
Grand Total	207	148	53	27	435	20	242	38	16	316	11	113	23	18	165	65	754	138	20	977	1893
Apprch %	47.6	34	12.2	6.2		6.3	76.6	12	5.1		6.7	68.5	13.9	10.9		6.7	77.2	14.1	2		
Total %	10.9	7.8	2.8	1.4	23	1.1	12.8	2	0.8	16.7	0.6	6	1.2	1	8.7	3.4	39.8	7.3	1.1	51.6	

Start Time	ARGUELLO ST Southbound				BREWSTER AVE Westbound				ARGUELLO ST Northbound				BREWSTER AVE Eastbound				Int. Total
	Right	Thru	Left	App. Total	Right	Thru	Left	App. Total	Right	Thru	Left	App. Total	Right	Thru	Left	App. Total	
07:45 AM	40	28	3	71	3	30	4	37	0	12	4	16	4	132	16	152	276
08:00 AM	51	18	9	78	4	41	10	55	3	18	2	23	9	117	29	155	311
08:15 AM	25	33	11	69	5	39	5	49	2	10	3	15	8	119	10	137	270
08:30 AM	18	18	13	49	0	29	4	33	1	22	2	25	20	129	23	172	279
Total Volume	134	97	36	267	12	139	23	174	6	62	11	79	41	497	78	616	1136
% App. Total	50.2	36.3	13.5		6.9	79.9	13.2		7.6	78.5	13.9		6.7	80.7	12.7		
PHF	.657	.735	.692	.856	.600	.848	.575	.791	.500	.705	.688	.790	.513	.941	.672	.895	.913

Peak Hour Analysis From 07:00 AM to 08:45 AM - Peak 1 of 1

Peak Hour for Entire Intersection Begins at 07:45 AM

Traffic Data Service

Campbell, CA

(408) 377-2988

tdsbay@cs.com

File Name : 64AM FINAL

Site Code : 00000064

Start Date : 6/6/2013

Page No : 2

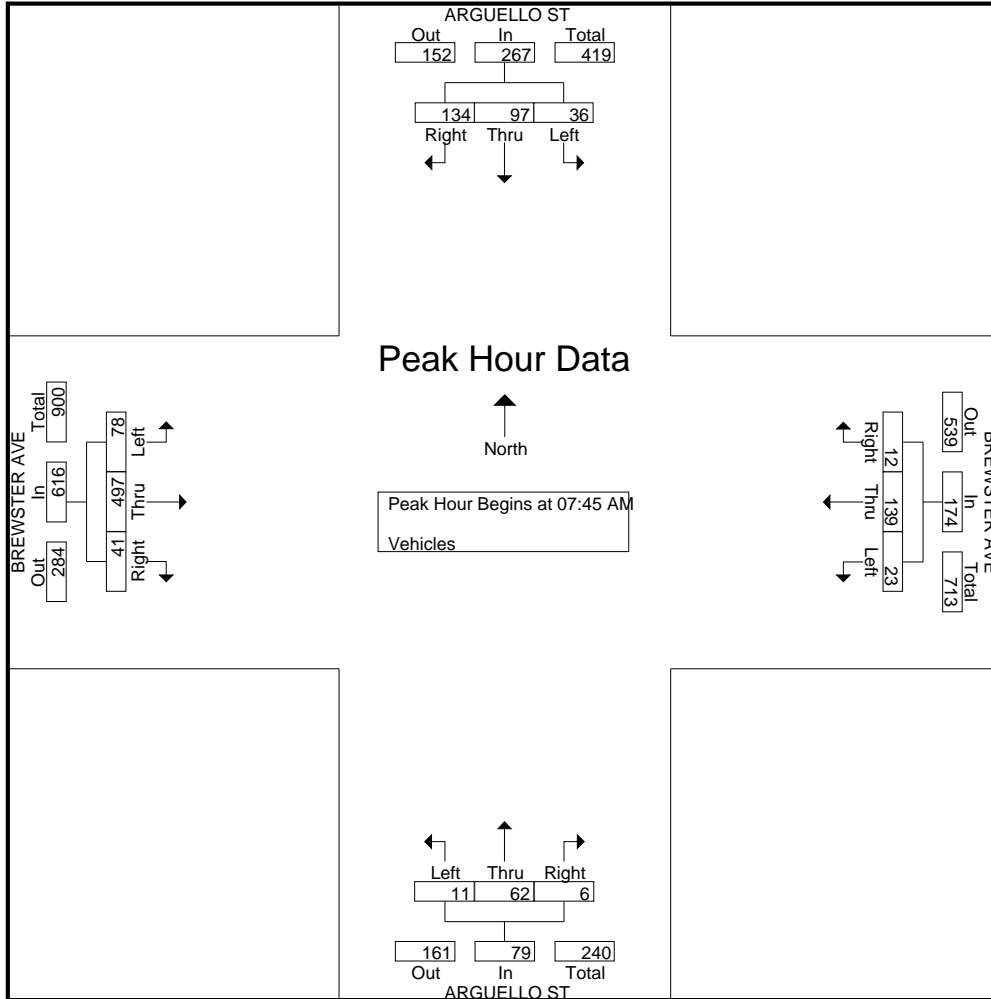

Traffic Data Service

Campbell, CA
 (408) 377-2988
 tdsbay@cs.com

File Name : 64AM FINAL
 Site Code : 00000064
 Start Date : 6/6/2013
 Page No : 1

Groups Printed- Bikes

Start Time	ARGUELLO ST Southbound					BREWSTER AVE Westbound					ARGUELLO ST Northbound					BREWSTER AVE Eastbound					Int. Total					
	Right	Thru	Left	Peds	App. Total	Right	Thru	Left	Peds	App. Total	Right	Thru	Left	Peds	App. Total	Right	Thru	Left	Peds	App. Total						
07:00 AM	0	0	0	0	0	0	0	0	0	0	0	4	0	0	4	0	0	0	0	0	0	0	0	0	0	4
07:15 AM	0	0	0	0	0	0	0	0	0	0	0	1	0	0	1	0	1	0	0	0	0	0	0	0	1	2
07:30 AM	0	0	0	0	0	0	0	0	0	0	0	0	0	0	0	0	0	0	0	0	0	0	0	0	0	0
07:45 AM	0	0	0	0	0	0	0	0	0	0	0	4	0	0	4	0	0	0	0	0	0	0	0	0	0	4
Total	0	0	0	0	0	0	0	0	0	0	0	9	0	0	9	0	1	0	0	0	0	0	0	0	1	10
08:00 AM	0	0	0	0	0	0	0	0	0	0	0	0	0	0	0	0	1	0	0	0	0	0	0	0	1	1
08:15 AM	2	0	0	0	2	0	0	0	0	0	0	2	0	0	2	0	3	0	0	0	0	0	0	0	3	7
08:30 AM	0	3	0	0	3	0	0	0	0	0	0	1	0	0	1	2	1	0	0	0	0	0	0	0	3	7
08:45 AM	0	0	0	0	0	1	1	0	0	2	0	0	0	0	0	0	0	0	0	0	0	0	0	0	0	2
Total	2	3	0	0	5	1	1	0	0	2	0	3	0	0	3	2	5	0	0	0	0	0	0	0	7	17
Grand Total	2	3	0	0	5	1	1	0	0	2	0	12	0	0	12	2	6	0	0	0	0	0	0	0	8	27
Apprch %	40	60	0	0		50	50	0	0		0	100	0	0		25	75	0	0							
Total %	7.4	11.1	0	0	18.5	3.7	3.7	0	0	7.4	0	44.4	0	0	44.4	7.4	22.2	0	0	29.6						

Start Time	ARGUELLO ST Southbound				BREWSTER AVE Westbound				ARGUELLO ST Northbound				BREWSTER AVE Eastbound				Int. Total
	Right	Thru	Left	App. Total	Right	Thru	Left	App. Total	Right	Thru	Left	App. Total	Right	Thru	Left	App. Total	
Peak Hour Analysis From 07:00 AM to 08:45 AM - Peak 1 of 1																	
Peak Hour for Entire Intersection Begins at 07:45 AM																	
07:45 AM	0	0	0	0	0	0	0	0	0	4	0	4	0	0	0	0	4
08:00 AM	0	0	0	0	0	0	0	0	0	0	0	0	0	1	0	0	1
08:15 AM	2	0	0	2	0	0	0	0	0	2	0	2	0	3	0	0	3
08:30 AM	0	3	0	3	0	0	0	0	0	1	0	1	2	1	0	0	3
Total Volume	2	3	0	5	0	0	0	0	0	7	0	7	2	5	0	0	7
% App. Total	40	60	0		0	0	0		0	100	0		28.6	71.4	0		
PHF	.250	.250	.000	.417	.000	.000	.000	.000	.000	.438	.000	.438	.250	.417	.000	.583	.679

Traffic Data Service

Campbell, CA

(408) 377-2988

tdsbay@cs.com

File Name : 64AM FINAL

Site Code : 00000064

Start Date : 6/6/2013

Page No : 2

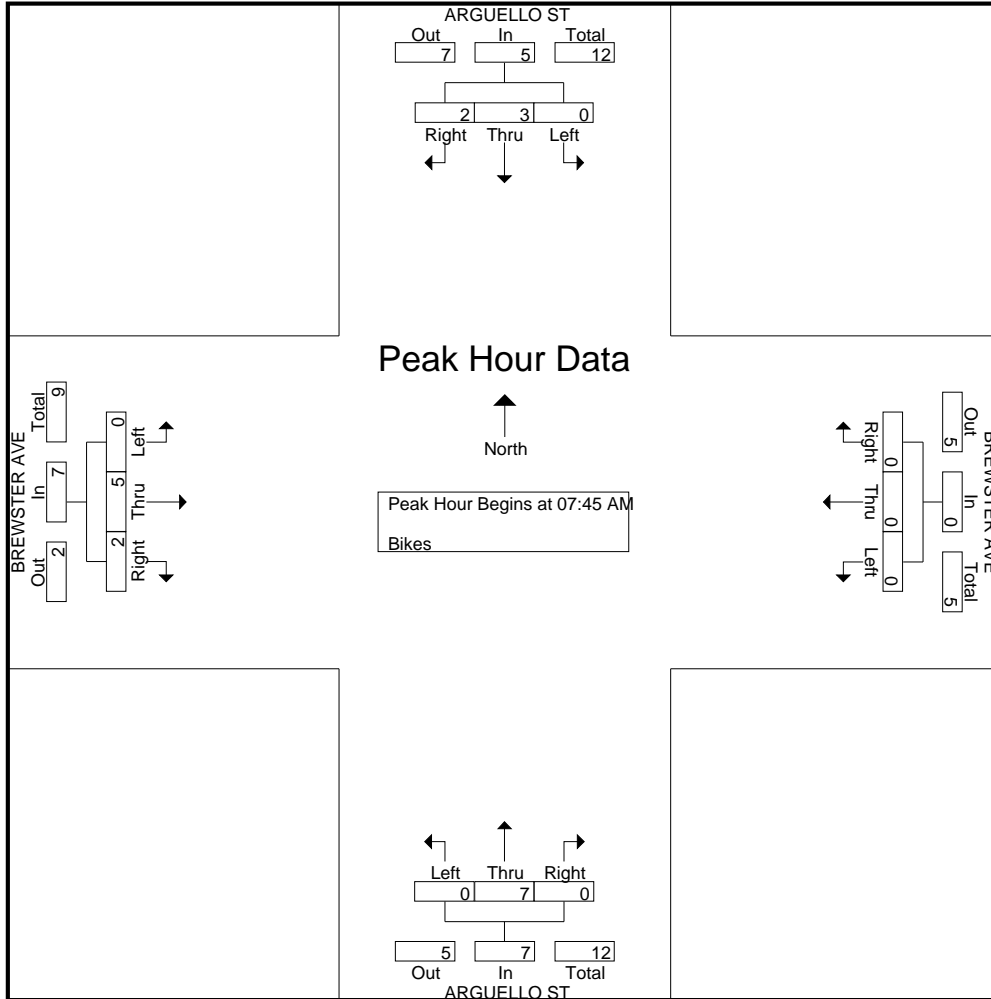

Traffic Data Service

Campbell, CA
 (408) 377-2988
 tdsbay@cs.com

File Name : 64PM FINAL
 Site Code : 00000064
 Start Date : 6/6/2013
 Page No : 1

Groups Printed- Vehicles

Start Time	ARGUELLO ST Southbound					BREWSTER AVE Westbound					ARGUELLO ST Northbound					BREWSTER AVE Eastbound					Int. Total
	Right	Thru	Left	Peds	App. Total	Right	Thru	Left	Peds	App. Total	Right	Thru	Left	Peds	App. Total	Right	Thru	Left	Peds	App. Total	
04:00 PM	20	17	7	7	51	9	84	4	8	105	6	22	7	7	42	4	48	13	2	67	265
04:15 PM	16	20	6	8	50	8	94	1	3	106	6	24	14	6	50	3	29	15	4	51	257
04:30 PM	23	19	1	4	47	8	86	4	1	99	8	37	10	0	55	6	56	34	3	99	300
04:45 PM	15	21	3	6	45	14	96	4	5	119	6	34	16	2	58	6	49	23	6	84	306
Total	74	77	17	25	193	39	360	13	17	429	26	117	47	15	205	19	182	85	15	301	1128
05:00 PM	23	31	4	3	61	11	111	2	2	126	16	34	18	0	68	10	48	26	1	85	340
05:15 PM	24	26	2	6	58	15	104	1	4	124	8	34	17	1	60	7	46	21	1	75	317
05:30 PM	32	20	4	5	61	9	102	3	4	118	6	29	20	8	63	3	50	25	9	87	329
05:45 PM	19	18	2	2	41	7	86	3	0	96	9	23	10	7	49	6	48	30	5	89	275
Total	98	95	12	16	221	42	403	9	10	464	39	120	65	16	240	26	192	102	16	336	1261
Grand Total	172	172	29	41	414	81	763	22	27	893	65	237	112	31	445	45	374	187	31	637	2389
Apprch %	41.5	41.5	7	9.9		9.1	85.4	2.5	3		14.6	53.3	25.2	7		7.1	58.7	29.4	4.9		
Total %	7.2	7.2	1.2	1.7	17.3	3.4	31.9	0.9	1.1	37.4	2.7	9.9	4.7	1.3	18.6	1.9	15.7	7.8	1.3	26.7	

Start Time	ARGUELLO ST Southbound				BREWSTER AVE Westbound				ARGUELLO ST Northbound				BREWSTER AVE Eastbound				Int. Total
	Right	Thru	Left	App. Total	Right	Thru	Left	App. Total	Right	Thru	Left	App. Total	Right	Thru	Left	App. Total	
04:45 PM	15	21	3	39	14	96	4	114	6	34	16	56	6	49	23	78	287
05:00 PM	23	31	4	58	11	111	2	124	16	34	18	68	10	48	26	84	334
05:15 PM	24	26	2	52	15	104	1	120	8	34	17	59	7	46	21	74	305
05:30 PM	32	20	4	56	9	102	3	114	6	29	20	55	3	50	25	78	303
Total Volume	94	98	13	205	49	413	10	472	36	131	71	238	26	193	95	314	1229
% App. Total	45.9	47.8	6.3		10.4	87.5	2.1		15.1	55	29.8		8.3	61.5	30.3		
PHF	.734	.790	.813	.884	.817	.930	.625	.952	.563	.963	.888	.875	.650	.965	.913	.935	.920

Peak Hour Analysis From 04:00 PM to 05:45 PM - Peak 1 of 1

Peak Hour for Entire Intersection Begins at 04:45 PM

Traffic Data Service

Campbell, CA
(408) 377-2988
tdsbay@cs.com

File Name : 64PM FINAL
Site Code : 00000064
Start Date : 6/6/2013
Page No : 2

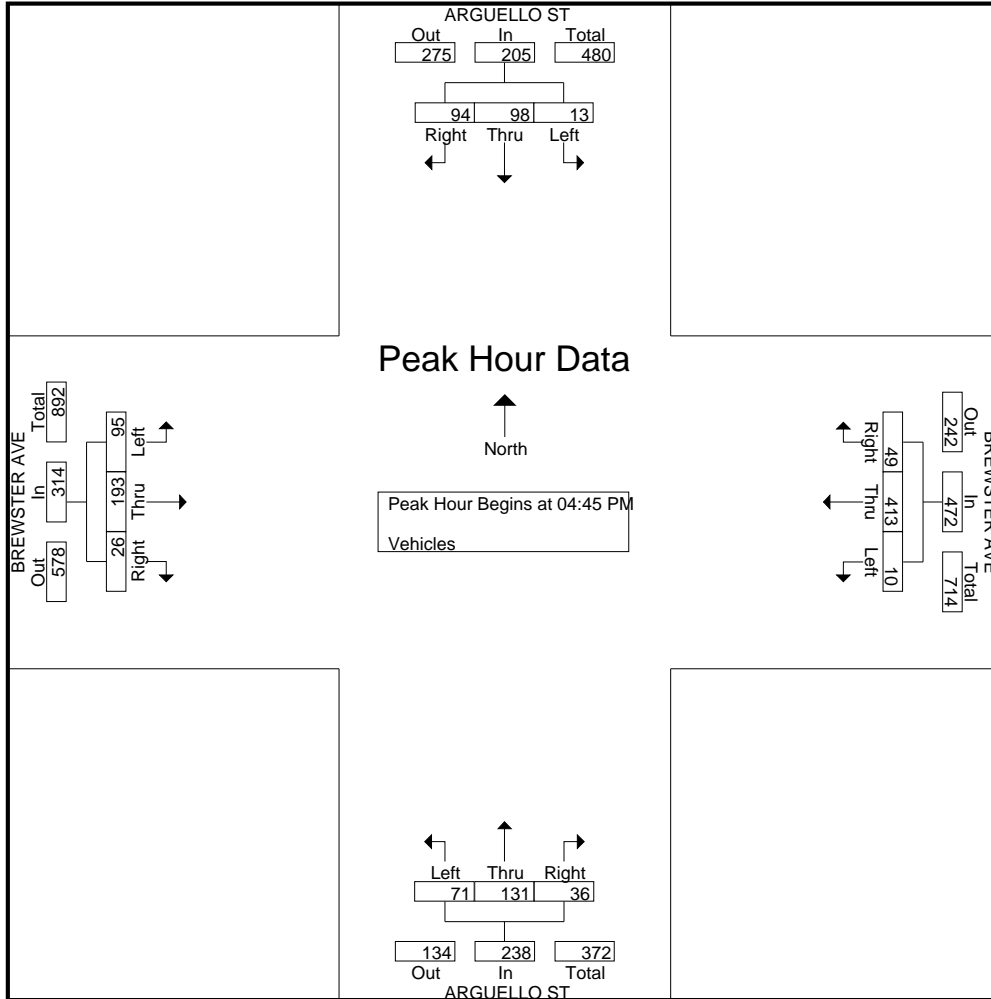

Traffic Data Service

Campbell, CA
 (408) 377-2988
 tdsbay@cs.com

File Name : 64PM FINAL
 Site Code : 00000064
 Start Date : 6/6/2013
 Page No : 1

Groups Printed- Bikes

Start Time	ARGUELLO ST Southbound					BREWSTER AVE Westbound					ARGUELLO ST Northbound					BREWSTER AVE Eastbound					Int. Total
	Right	Thru	Left	Peds	App. Total	Right	Thru	Left	Peds	App. Total	Right	Thru	Left	Peds	App. Total	Right	Thru	Left	Peds	App. Total	
04:00 PM	0	1	0	0	1	0	0	0	0	0	0	0	0	0	0	0	0	1	0	1	2
04:15 PM	0	2	0	0	2	0	0	0	0	0	1	1	1	0	3	0	0	0	0	0	5
04:30 PM	0	0	0	0	0	0	0	0	0	0	1	0	0	0	1	0	0	0	0	0	1
04:45 PM	0	3	0	0	3	0	0	0	0	0	1	2	0	0	3	0	0	0	0	0	6
Total	0	6	0	0	6	0	0	0	0	0	3	3	1	0	7	0	0	1	0	1	14
05:00 PM	0	0	0	0	0	0	0	0	0	0	0	0	0	0	0	0	1	0	0	1	1
05:15 PM	0	2	0	0	2	0	0	0	0	0	0	3	0	0	3	0	0	0	0	0	5
05:30 PM	0	0	0	0	0	0	0	0	0	0	0	2	0	0	2	0	0	0	0	0	2
05:45 PM	0	1	0	0	1	0	1	0	0	1	0	1	0	0	1	0	1	0	0	1	4
Total	0	3	0	0	3	0	1	0	0	1	0	6	0	0	6	0	2	0	0	2	12
Grand Total	0	9	0	0	9	0	1	0	0	1	3	9	1	0	13	0	2	1	0	3	26
Apprch %	0	100	0	0		0	100	0	0		23.1	69.2	7.7	0		0	66.7	33.3	0		
Total %	0	34.6	0	0	34.6	0	3.8	0	0	3.8	11.5	34.6	3.8	0	50	0	7.7	3.8	0	11.5	

Start Time	ARGUELLO ST Southbound					BREWSTER AVE Westbound					ARGUELLO ST Northbound					BREWSTER AVE Eastbound					Int. Total
	Right	Thru	Left	Peds	App. Total	Right	Thru	Left	Peds	App. Total	Right	Thru	Left	Peds	App. Total	Right	Thru	Left	Peds	App. Total	
04:00 PM	0	1	0	0	1	0	0	0	0	0	0	0	0	0	0	0	0	1	0	1	2
04:15 PM	0	2	0	0	2	0	0	0	0	0	1	1	1	0	3	0	0	0	0	0	5
04:30 PM	0	0	0	0	0	0	0	0	0	0	1	0	0	0	1	0	0	0	0	0	1
04:45 PM	0	3	0	0	3	0	0	0	0	0	1	2	0	0	3	0	0	0	0	0	6
Total Volume	0	6	0	0	6	0	0	0	0	0	3	3	1	0	7	0	0	1	0	1	14
% App. Total	0	100	0	0		0	0	0	0		42.9	42.9	14.3	0		0	0	100	0		
PHF	.000	.500	.000	.000	.500	.000	.000	.000	.000	.000	.750	.375	.250	.583		.000	.000	.250	.250	.583	

Peak Hour Analysis From 04:00 PM to 05:45 PM - Peak 1 of 1

Peak Hour for Entire Intersection Begins at 04:00 PM

Traffic Data Service

Campbell, CA

(408) 377-2988

tdsbay@cs.com

File Name : 64PM FINAL

Site Code : 00000064

Start Date : 6/6/2013

Page No : 2

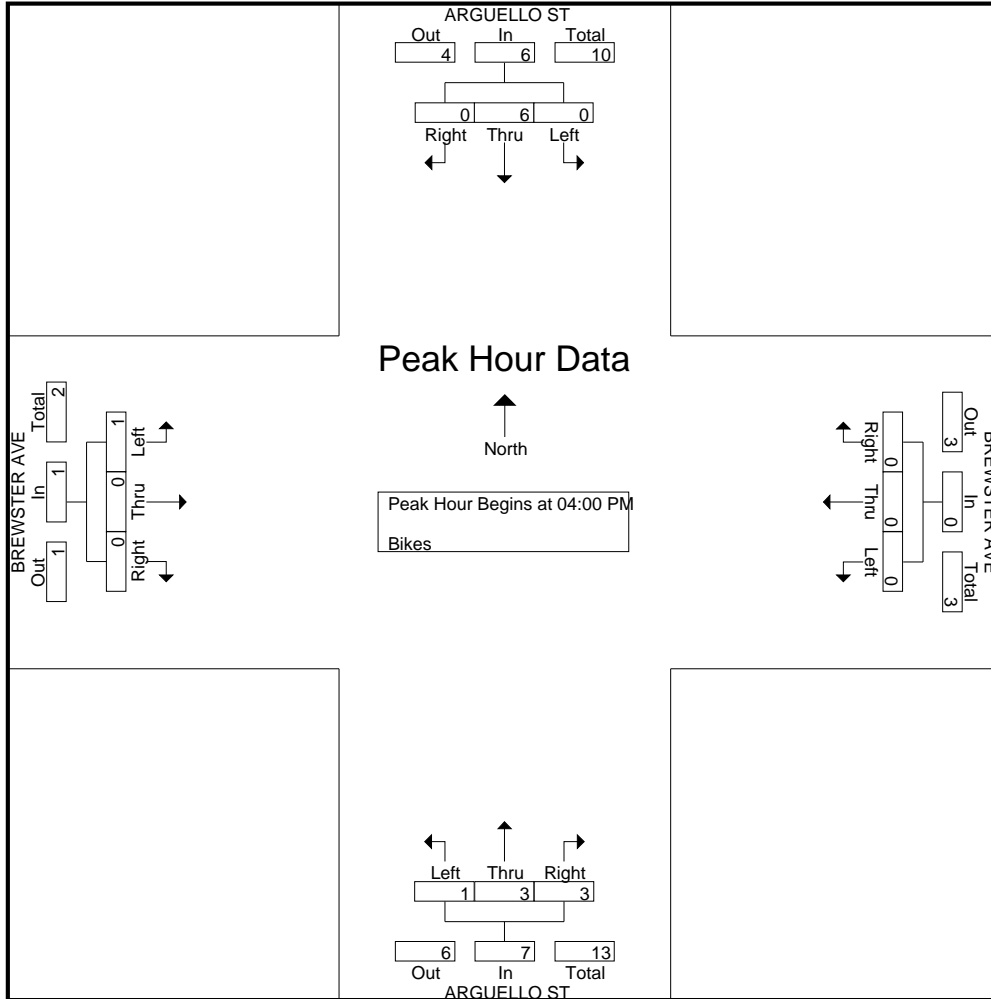

fp

Groups Printed- Vehicles Only

Start Time	EL CAMINO REAL Southbound				BROADWAY Westbound				EL CAMINO REAL Northbound					BROADWAY Eastbound				Int. Total
	RT	TH	LT	App. Total	RT	TH	LT	App. Total	RT	TH	LT	U-turn	App. Total	RT	TH	LT	App. Total	
07:00	0	115	11	126	0	4	0	4	11	75	14	0	100	33	17	0	50	280
07:15	1	218	16	235	5	19	4	28	9	163	13	1	186	35	30	0	65	514
07:30	2	185	26	213	9	19	13	41	11	202	22	1	236	58	42	3	103	593
07:45	6	229	44	279	5	37	6	48	14	253	42	2	311	89	57	1	147	785
Total	9	747	97	853	19	79	23	121	45	693	91	4	833	215	146	4	365	2172
08:00	1	239	10	250	10	24	6	40	18	273	31	0	322	85	64	1	150	762
08:15	1	268	21	290	16	14	7	37	30	245	27	0	302	49	54	1	104	733
08:30	0	235	21	256	5	9	10	24	14	236	26	0	276	49	29	1	79	635
08:45	3	225	22	250	5	10	4	19	13	244	25	2	284	44	43	1	88	641
Total	5	967	74	1046	36	57	27	120	75	998	109	2	1184	227	190	4	421	2771
Grand Total	14	1714	171	1899	55	136	50	241	120	1691	200	6	2017	442	336	8	786	4943
Apprch %	0.7	90.3	9		22.8	56.4	20.7		5.9	83.8	9.9	0.3		56.2	42.7	1		
Total %	0.3	34.7	3.5	38.4	1.1	2.8	1	4.9	2.4	34.2	4	0.1	40.8	8.9	6.8	0.2	15.9	

Start Time	EL CAMINO REAL Southbound				BROADWAY Westbound				EL CAMINO REAL Northbound					BROADWAY Eastbound				Int. Total
	RT	TH	LT	App. Total	RT	TH	LT	App. Total	RT	TH	LT	U-turn	App. Total	RT	TH	LT	App. Total	
07:45	6	229	44	279	5	37	6	48	14	253	42	2	311	89	57	1	147	785
08:00	1	239	10	250	10	24	6	40	18	273	31	0	322	85	64	1	150	762
08:15	1	268	21	290	16	14	7	37	30	245	27	0	302	49	54	1	104	733
08:30	0	235	21	256	5	9	10	24	14	236	26	0	276	49	29	1	79	635
Total Volume	8	971	96	1075	36	84	29	149	76	1007	126	2	1211	272	204	4	480	2915
% App. Total	0.7	90.3	8.9		24.2	56.4	19.5		6.3	83.2	10.4	0.2		56.7	42.5	0.8		
PHF	.333	.906	.545	.927	.563	.568	.725	.776	.633	.922	.750	.250	.940	.764	.797	1.000	.800	.928

Peak Hour Analysis From 07:00 to 08:45 - Peak 1 of 1

Peak Hour for Entire Intersection Begins at 07:45

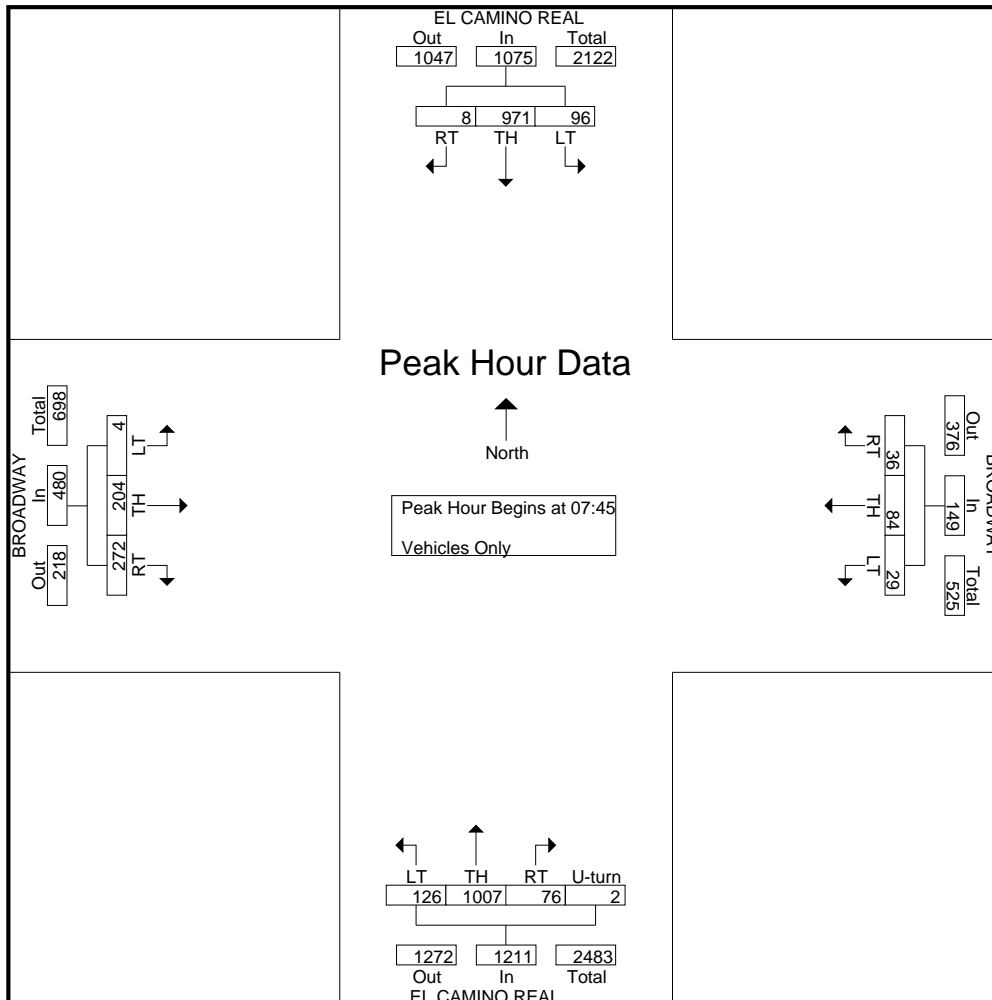

fp

Groups Printed- Vehicles Only

Start Time	EL CAMINO REAL Southbound				BROADWAY Westbound				EL CAMINO REAL Northbound					BROADWAY Eastbound				Int. Total
	RT	TH	LT	App. Total	RT	TH	LT	App. Total	RT	TH	LT	U-turn	App. Total	RT	TH	LT	App. Total	
16:00	3	286	16	305	16	32	18	66	16	266	26	0	308	35	20	0	55	734
16:15	4	271	14	289	27	34	13	74	19	325	32	1	377	45	13	1	59	799
16:30	6	283	18	307	18	33	14	65	11	302	42	2	357	53	21	0	74	803
16:45	4	272	15	291	16	38	29	83	20	267	38	1	326	45	30	4	79	779
Total	17	1112	63	1192	77	137	74	288	66	1160	138	4	1368	178	84	5	267	3115
17:00	7	257	26	290	29	41	15	85	28	316	35	3	382	39	25	2	66	823
17:15	2	301	20	323	15	46	18	79	21	329	36	1	387	41	21	2	64	853
17:30	2	283	12	297	24	43	14	81	23	312	36	4	375	52	24	3	79	832
17:45	6	272	16	294	20	29	13	62	27	293	40	4	364	30	21	0	51	771
Total	17	1113	74	1204	88	159	60	307	99	1250	147	12	1508	162	91	7	260	3279
Grand Total	34	2225	137	2396	165	296	134	595	165	2410	285	16	2876	340	175	12	527	6394
Apprch %	1.4	92.9	5.7		27.7	49.7	22.5		5.7	83.8	9.9	0.6		64.5	33.2	2.3		
Total %	0.5	34.8	2.1	37.5	2.6	4.6	2.1	9.3	2.6	37.7	4.5	0.3	45	5.3	2.7	0.2	8.2	

Start Time	EL CAMINO REAL Southbound				BROADWAY Westbound				EL CAMINO REAL Northbound					BROADWAY Eastbound				Int. Total
	RT	TH	LT	App. Total	RT	TH	LT	App. Total	RT	TH	LT	U-turn	App. Total	RT	TH	LT	App. Total	
16:45	4	272	15	291	16	38	29	83	20	267	38	1	326	45	30	4	79	779
17:00	7	257	26	290	29	41	15	85	28	316	35	3	382	39	25	2	66	823
17:15	2	301	20	323	15	46	18	79	21	329	36	1	387	41	21	2	64	853
17:30	2	283	12	297	24	43	14	81	23	312	36	4	375	52	24	3	79	832
Total Volume	15	1113	73	1201	84	168	76	328	92	1224	145	9	1470	177	100	11	288	3287
% App. Total	1.2	92.7	6.1		25.6	51.2	23.2		6.3	83.3	9.9	0.6		61.5	34.7	3.8		
PHF	.536	.924	.702	.930	.724	.913	.655	.965	.821	.930	.954	.563	.950	.851	.833	.688	.911	.963

Peak Hour Analysis From 16:00 to 17:45 - Peak 1 of 1

Peak Hour for Entire Intersection Begins at 16:45

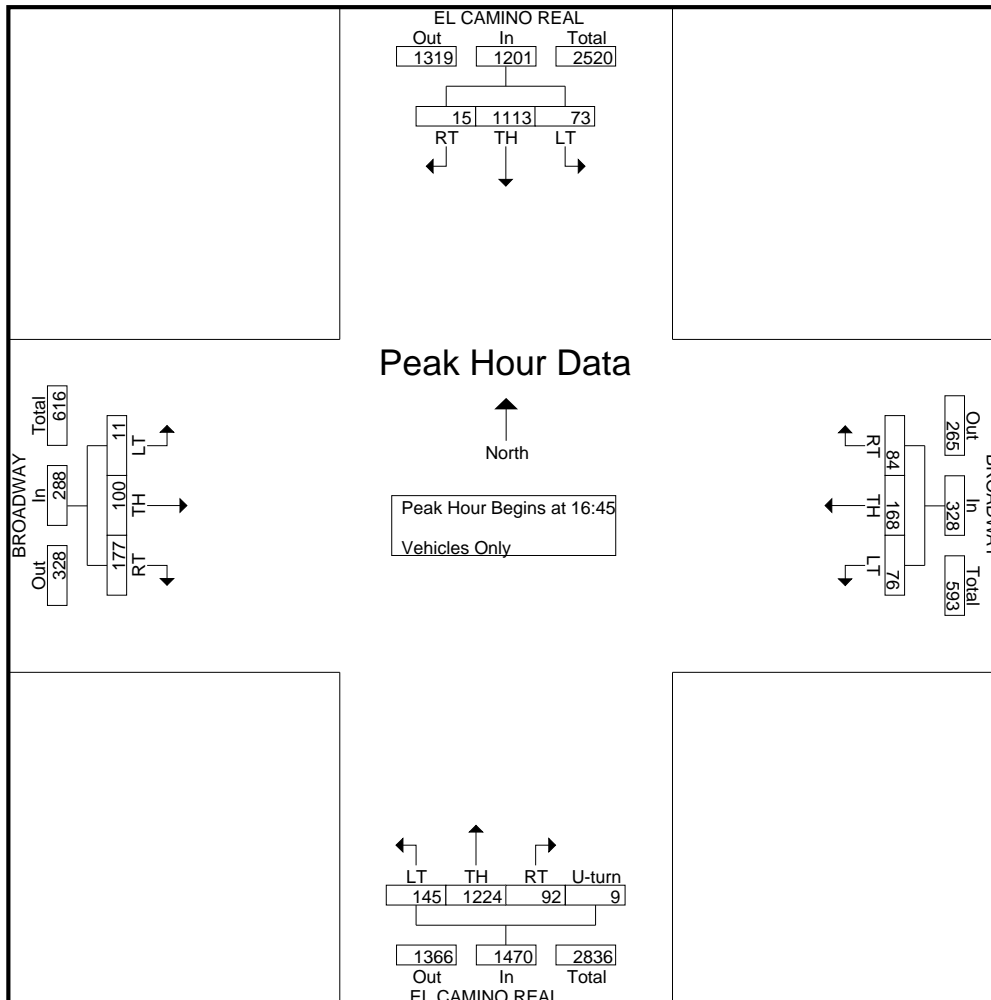

fp

Groups Printed- Vehicles Only

Start Time	ARGUELLO ST Southbound				MARSHALL ST Westbound				BROADWAY Northbound				BROADWAY Eastbound				Int. Total
	RT	TH	LT	App. Total	RT	TH	LT	App. Total	RT	TH	LT	App. Total	RT	TH	LT	App. Total	
07:00	3	5	3	11	3	19	1	23	3	7	2	12	4	30	1	35	81
07:15	4	10	5	19	9	23	0	32	1	9	6	16	8	32	4	44	111
07:30	10	5	5	20	12	30	0	42	1	8	9	18	14	35	6	55	135
07:45	5	13	8	26	10	45	0	55	2	11	13	26	14	63	6	83	190
Total	22	33	21	76	34	117	1	152	7	35	30	72	40	160	17	217	517
08:00	9	14	5	28	12	28	5	45	6	17	11	34	23	48	5	76	183
08:15	8	19	13	40	9	18	0	27	2	14	6	22	25	50	4	79	168
08:30	6	12	10	28	15	28	2	45	2	10	5	17	17	54	4	75	165
08:45	4	13	7	24	10	30	2	42	2	15	6	23	20	40	4	64	153
Total	27	58	35	120	46	104	9	159	12	56	28	96	85	192	17	294	669
Grand Total	49	91	56	196	80	221	10	311	19	91	58	168	125	352	34	511	1186
Approch %	25	46.4	28.6		25.7	71.1	3.2		11.3	54.2	34.5		24.5	68.9	6.7		
Total %	4.1	7.7	4.7	16.5	6.7	18.6	0.8	26.2	1.6	7.7	4.9	14.2	10.5	29.7	2.9	43.1	

Start Time	ARGUELLO ST Southbound				MARSHALL ST Westbound				BROADWAY Northbound				BROADWAY Eastbound				Int. Total
	RT	TH	LT	App. Total	RT	TH	LT	App. Total	RT	TH	LT	App. Total	RT	TH	LT	App. Total	
07:45	5	13	8	26	10	45	0	55	2	11	13	26	14	63	6	83	190
08:00	9	14	5	28	12	28	5	45	6	17	11	34	23	48	5	76	183
08:15	8	19	13	40	9	18	0	27	2	14	6	22	25	50	4	79	168
08:30	6	12	10	28	15	28	2	45	2	10	5	17	17	54	4	75	165
Total Volume	28	58	36	122	46	119	7	172	12	52	35	99	79	215	19	313	706
% App. Total	23	47.5	29.5		26.7	69.2	4.1		12.1	52.5	35.4		25.2	68.7	6.1		
PHF	.778	.763	.692	.763	.767	.661	.350	.782	.500	.765	.673	.728	.790	.853	.792	.943	.929

Peak Hour Analysis From 07:00 to 08:45 - Peak 1 of 1

Peak Hour for Entire Intersection Begins at 07:45

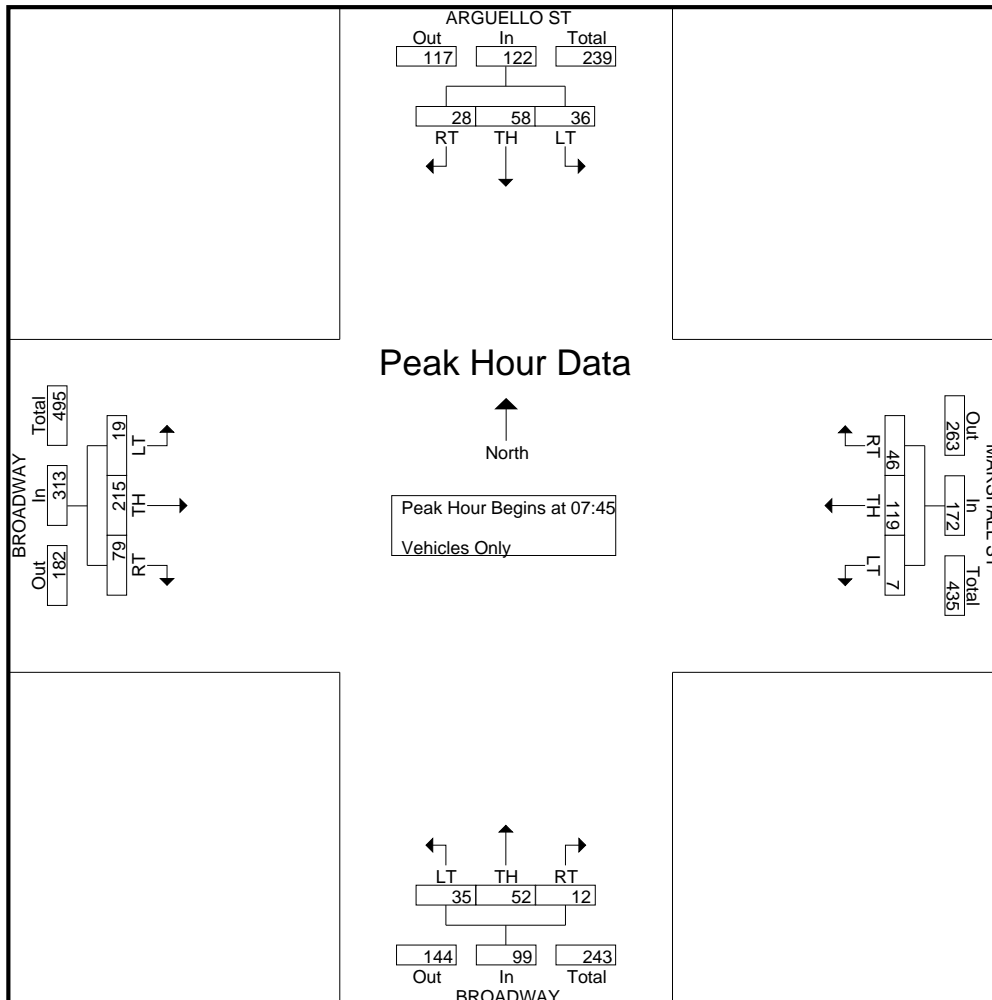

MARKS TRAFFIC DATA

mietekm@comcast.net

916.806.0250

CITY OF REDWOOD CITY

File Name : arguello-marshall-p

Site Code : 29

Start Date : 5/19/2011

Page No : 1

fp

Groups Printed- Vehicles Only

Start Time	ARGUELLO ST Southbound				MARSHALL ST Westbound				BROADWAY Northbound				BROADWAY Eastbound				Int. Total
	RT	TH	LT	App. Total	RT	TH	LT	App. Total	RT	TH	LT	App. Total	RT	TH	LT	App. Total	
16:00	11	17	4	32	15	49	2	66	4	13	35	52	15	38	3	56	206
16:15	6	26	6	38	10	45	0	55	3	18	22	43	25	23	3	51	187
16:30	14	21	4	39	29	52	1	82	3	10	30	43	21	28	2	51	215
16:45	11	27	7	45	27	54	3	84	2	22	19	43	22	29	2	53	225
Total	42	91	21	154	81	200	6	287	12	63	106	181	83	118	10	211	833
17:00	9	17	6	32	19	73	2	94	0	16	23	39	22	44	9	75	240
17:15	6	14	10	30	23	70	3	96	4	18	35	57	24	21	4	49	232
17:30	10	21	6	37	20	39	1	60	1	16	21	38	19	30	8	57	192
17:45	8	17	8	33	22	38	3	63	1	13	24	38	19	25	2	46	180
Total	33	69	30	132	84	220	9	313	6	63	103	172	84	120	23	227	844
Grand Total	75	160	51	286	165	420	15	600	18	126	209	353	167	238	33	438	1677
Apprch %	26.2	55.9	17.8		27.5	70	2.5		5.1	35.7	59.2		38.1	54.3	7.5		
Total %	4.5	9.5	3	17.1	9.8	25	0.9	35.8	1.1	7.5	12.5	21	10	14.2	2	26.1	

Start Time	ARGUELLO ST Southbound				MARSHALL ST Westbound				BROADWAY Northbound				BROADWAY Eastbound				Int. Total
	RT	TH	LT	App. Total	RT	TH	LT	App. Total	RT	TH	LT	App. Total	RT	TH	LT	App. Total	
16:30	14	21	4	39	29	52	1	82	3	10	30	43	21	28	2	51	215
16:45	11	27	7	45	27	54	3	84	2	22	19	43	22	29	2	53	225
17:00	9	17	6	32	19	73	2	94	0	16	23	39	22	44	9	75	240
17:15	6	14	10	30	23	70	3	96	4	18	35	57	24	21	4	49	232
Total Volume	40	79	27	146	98	249	9	356	9	66	107	182	89	122	17	228	912
% App. Total	27.4	54.1	18.5		27.5	69.9	2.5		4.9	36.3	58.8		39	53.5	7.5		
PHF	.714	.731	.675	.811	.845	.853	.750	.927	.563	.750	.764	.798	.927	.693	.472	.760	.950

Peak Hour Analysis From 16:00 to 17:45 - Peak 1 of 1

Peak Hour for Entire Intersection Begins at 16:30

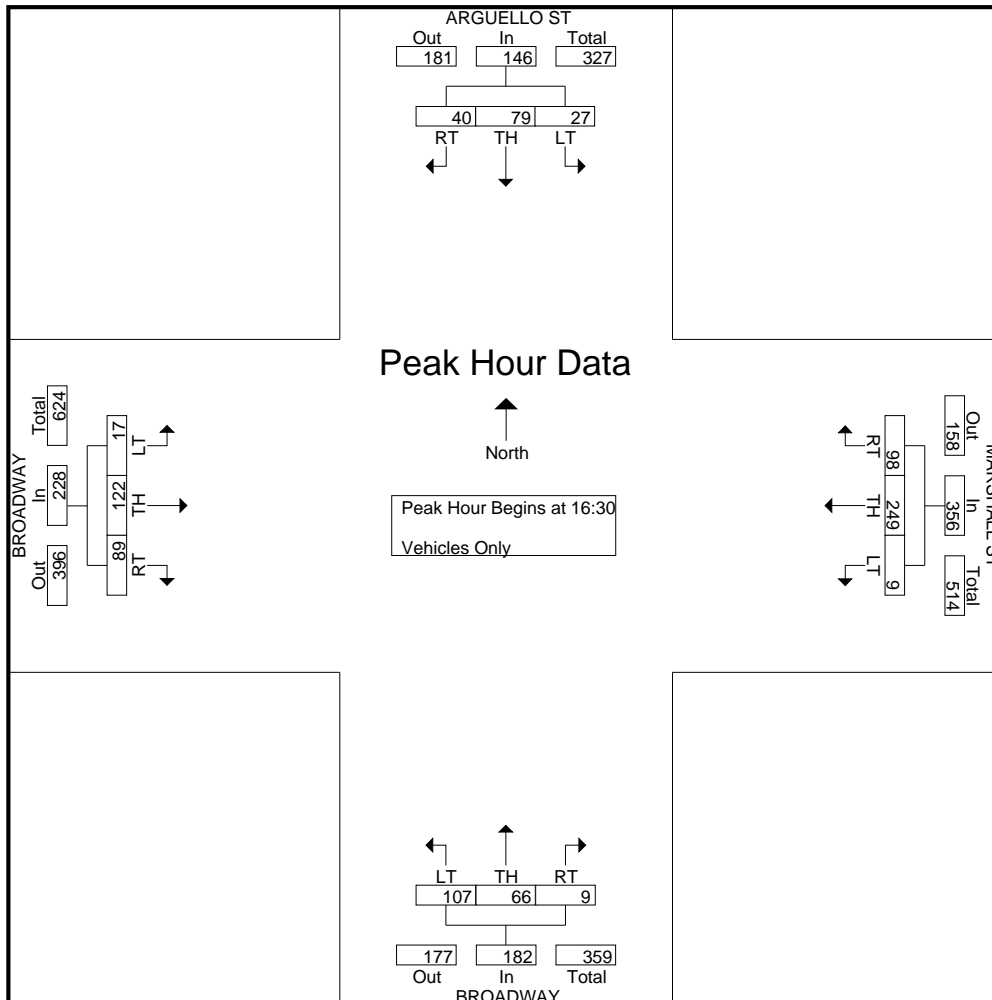

Traffic Data Service

Campbell, CA
 (408) 377-2988
 tdsbay@cs.com

File Name : 15AM FINAL
 Site Code : 00000015
 Start Date : 5/22/2013
 Page No : 1

Groups Printed- Vehicles

Start Time	EL CAMINO REAL Southbound					JAMES AVE Westbound					EL CAMINO REAL Northbound					JAMES AVE Eastbound					Int. Total
	Right	Thru	Left	Peds	App. Total	Right	Thru	Left	Peds	App. Total	Right	Thru	Left	Peds	App. Total	Right	Thru	Left	Peds	App. Total	
07:00 AM	6	164	10	5	185	13	2	11	1	27	14	162	11	5	192	6	9	18	1	34	438
07:15 AM	13	257	17	9	296	4	19	11	4	38	20	221	31	7	279	15	16	11	2	44	657
07:30 AM	29	285	25	6	345	8	14	14	7	43	24	217	46	16	303	29	18	21	2	70	761
07:45 AM	29	242	7	20	298	12	16	6	4	38	11	266	57	12	346	45	23	27	4	99	781
Total	77	948	59	40	1124	37	51	42	16	146	69	866	145	40	1120	95	66	77	9	247	2637
08:00 AM	34	274	24	57	389	15	24	12	10	61	8	297	46	7	358	45	18	39	4	106	914
08:15 AM	23	303	24	46	396	10	15	11	8	44	25	260	45	18	348	40	28	40	2	110	898
08:30 AM	14	294	33	35	376	6	7	21	0	34	13	277	18	6	314	34	20	31	6	91	815
08:45 AM	7	259	14	5	285	12	8	11	2	33	10	251	15	7	283	19	15	14	5	53	654
Total	78	1130	95	143	1446	43	54	55	20	172	56	1085	124	38	1303	138	81	124	17	360	3281
Grand Total	155	2078	154	183	2570	80	105	97	36	318	125	1951	269	78	2423	233	147	201	26	607	5918
Apprch %	6	80.9	6	7.1		25.2	33	30.5	11.3		5.2	80.5	11.1	3.2		38.4	24.2	33.1	4.3		
Total %	2.6	35.1	2.6	3.1	43.4	1.4	1.8	1.6	0.6	5.4	2.1	33	4.5	1.3	40.9	3.9	2.5	3.4	0.4	10.3	

Start Time	EL CAMINO REAL Southbound				JAMES AVE Westbound				EL CAMINO REAL Northbound				JAMES AVE Eastbound				Int. Total
	Right	Thru	Left	App. Total	Right	Thru	Left	App. Total	Right	Thru	Left	App. Total	Right	Thru	Left	App. Total	
07:45 AM	29	242	7	278	12	16	6	34	11	266	57	334	45	23	27	95	741
08:00 AM	34	274	24	332	15	24	12	51	8	297	46	351	45	18	39	102	836
08:15 AM	23	303	24	350	10	15	11	36	25	260	45	330	40	28	40	108	824
08:30 AM	14	294	33	341	6	7	21	34	13	277	18	308	34	20	31	85	768
Total Volume	100	1113	88	1301	43	62	50	155	57	1100	166	1323	164	89	137	390	3169
% App. Total	7.7	85.5	6.8		27.7	40	32.3		4.3	83.1	12.5		42.1	22.8	35.1		
PHF	.735	.918	.667	.929	.717	.646	.595	.760	.570	.926	.728	.942	.911	.795	.856	.903	.948

Peak Hour Analysis From 07:00 AM to 08:45 AM - Peak 1 of 1

Peak Hour for Entire Intersection Begins at 07:45 AM

Traffic Data Service

Campbell, CA
 (408) 377-2988
 tdsbay@cs.com

File Name : 15AM FINAL
 Site Code : 00000015
 Start Date : 5/22/2013
 Page No : 2

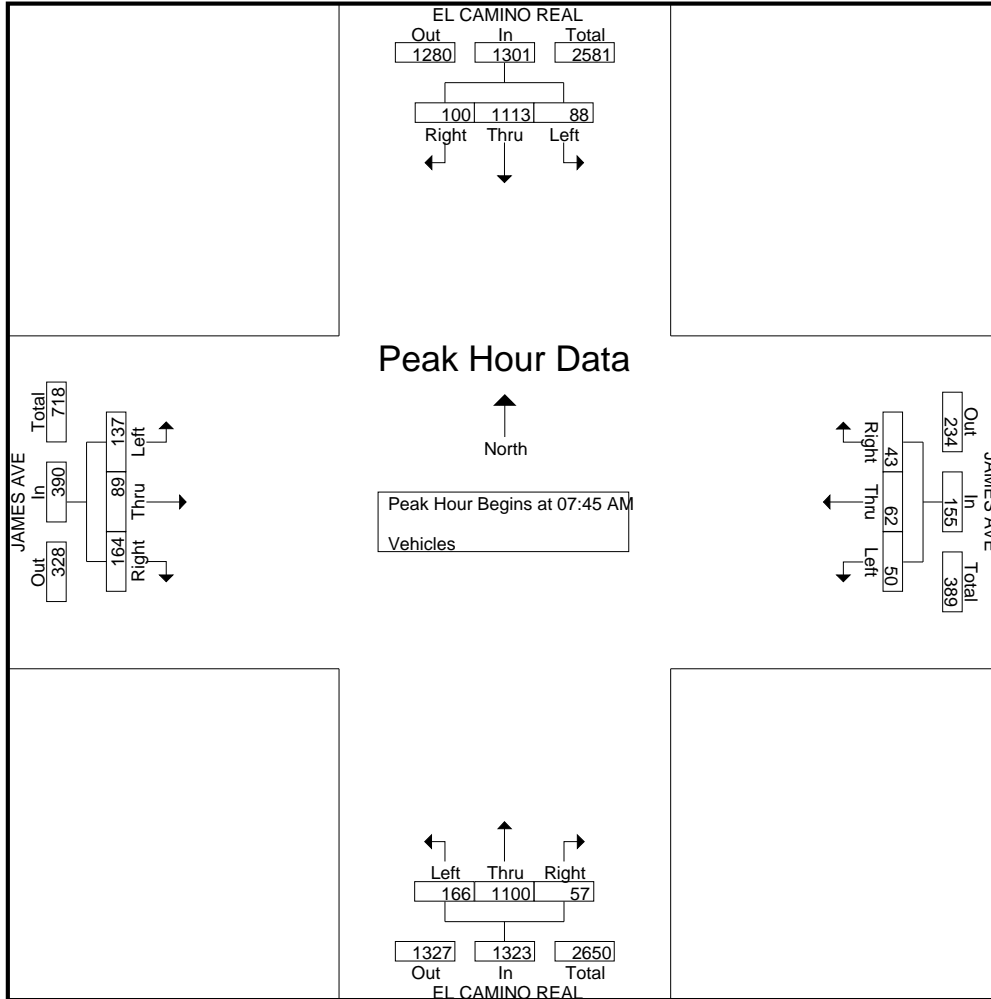

Traffic Data Service

Campbell, CA
 (408) 377-2988
 tdsbay@cs.com

File Name : 15AM FINAL
 Site Code : 00000015
 Start Date : 5/22/2013
 Page No : 1

Groups Printed- Bikes

Start Time	EL CAMINO REAL Southbound					JAMES AVE Westbound					EL CAMINO REAL Northbound					JAMES AVE Eastbound					Int. Total
	Right	Thru	Left	Peds	App. Total	Right	Thru	Left	Peds	App. Total	Right	Thru	Left	Peds	App. Total	Right	Thru	Left	Peds	App. Total	
07:00 AM	0	1	0	0	1	0	0	0	0	0	0	0	1	0	1	0	4	1	0	5	7
07:15 AM	0	2	0	0	2	0	3	0	0	3	1	1	0	0	2	0	6	0	0	6	13
07:30 AM	0	2	0	0	2	0	1	0	0	1	0	1	0	0	1	0	3	5	0	8	12
07:45 AM	0	4	0	0	4	0	0	0	0	0	0	0	0	0	0	0	0	0	0	0	4
Total	0	9	0	0	9	0	4	0	0	4	1	2	1	0	4	0	13	6	0	19	36
08:00 AM	0	1	0	0	1	0	0	0	0	0	0	2	0	0	2	0	2	0	0	2	5
08:15 AM	0	0	0	0	0	0	2	0	0	2	0	1	0	0	1	0	6	0	0	6	9
08:30 AM	0	0	0	1	1	0	3	0	0	3	0	1	0	0	1	0	1	0	0	1	6
08:45 AM	0	2	0	0	2	0	1	0	0	1	0	1	0	0	1	0	3	0	0	3	7
Total	0	3	0	1	4	0	6	0	0	6	0	5	0	0	5	0	12	0	0	12	27
Grand Total	0	12	0	1	13	0	10	0	0	10	1	7	1	0	9	0	25	6	0	31	63
Apprch %	0	92.3	0	7.7		0	100	0	0		11.1	77.8	11.1	0		0	80.6	19.4	0		
Total %	0	19	0	1.6	20.6	0	15.9	0	0	15.9	1.6	11.1	1.6	0	14.3	0	39.7	9.5	0	49.2	

Start Time	EL CAMINO REAL Southbound					JAMES AVE Westbound					EL CAMINO REAL Northbound					JAMES AVE Eastbound					Int. Total
	Right	Thru	Left	Peds	App. Total	Right	Thru	Left	Peds	App. Total	Right	Thru	Left	Peds	App. Total	Right	Thru	Left	Peds	App. Total	
07:00 AM	0	1	0	0	1	0	0	0	0	0	0	0	1	0	1	0	4	1	0	5	7
07:15 AM	0	2	0	0	2	0	3	0	0	3	1	1	0	0	2	0	6	0	0	6	13
07:30 AM	0	2	0	0	2	0	1	0	0	1	0	1	0	0	1	0	3	5	0	8	12
07:45 AM	0	4	0	0	4	0	0	0	0	0	0	0	0	0	0	0	0	0	0	0	4
Total Volume	0	9	0	0	9	0	4	0	0	4	1	2	1	0	4	0	13	6	0	19	36
% App. Total	0	100	0	0		0	100	0	0		25	50	25	0		0	68.4	31.6	0		
PHF	.000	.563	.000	.000	.563	.000	.333	.000	.000	.333	.250	.500	.250	.000	.500	.000	.542	.300	.000	.594	.692

Peak Hour Analysis From 07:00 AM to 08:45 AM - Peak 1 of 1

Peak Hour for Entire Intersection Begins at 07:00 AM

Traffic Data Service

Campbell, CA
(408) 377-2988
tdsbay@cs.com

File Name : 15AM FINAL
Site Code : 00000015
Start Date : 5/22/2013
Page No : 2

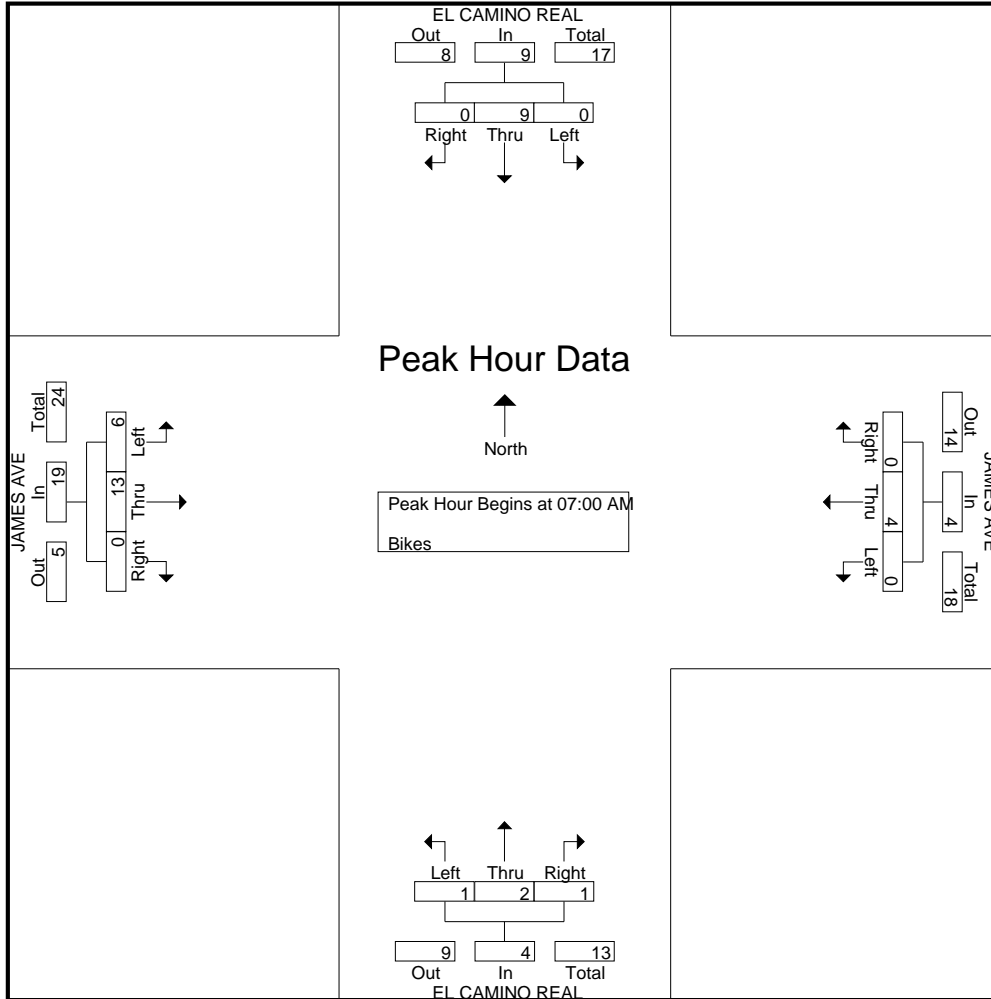

Traffic Data Service

Campbell, CA
 (408) 377-2988
 tdsbay@cs.com

File Name : 15PM FINAL
 Site Code : 00000015
 Start Date : 5/22/2013
 Page No : 1

Groups Printed- Vehicles

Start Time	EL CAMINO REAL Southbound					JAMES AVE Westbound					EL CAMINO REAL Northbound					JAMES AVE Eastbound					Int. Total
	Right	Thru	Left	Peds	App. Total	Right	Thru	Left	Peds	App. Total	Right	Thru	Left	Peds	App. Total	Right	Thru	Left	Peds	App. Total	
04:00 PM	19	259	27	35	340	23	21	19	7	70	10	327	37	15	389	30	16	21	2	69	868
04:15 PM	11	266	31	11	319	19	17	29	6	71	7	313	21	6	347	15	12	25	5	57	794
04:30 PM	18	309	23	13	363	20	21	23	9	73	12	325	18	4	359	23	12	25	4	64	859
04:45 PM	13	313	20	13	359	19	19	17	9	64	5	354	21	14	394	23	8	17	3	51	868
Total	61	1147	101	72	1381	81	78	88	31	278	34	1319	97	39	1489	91	48	88	14	241	3389
05:00 PM	14	309	24	5	352	21	30	32	5	88	8	341	22	11	382	13	13	17	4	47	869
05:15 PM	21	309	32	8	370	12	28	27	9	76	9	327	48	8	392	20	13	22	0	55	893
05:30 PM	23	293	25	11	352	19	31	27	4	81	6	352	26	8	392	38	10	22	3	73	898
05:45 PM	16	337	32	14	399	20	15	24	0	59	13	319	26	8	366	19	16	20	3	58	882
Total	74	1248	113	38	1473	72	104	110	18	304	36	1339	122	35	1532	90	52	81	10	233	3542
Grand Total	135	2395	214	110	2854	153	182	198	49	582	70	2658	219	74	3021	181	100	169	24	474	6931
Apprch %	4.7	83.9	7.5	3.9		26.3	31.3	34	8.4		2.3	88	7.2	2.4		38.2	21.1	35.7	5.1		
Total %	1.9	34.6	3.1	1.6	41.2	2.2	2.6	2.9	0.7	8.4	1	38.3	3.2	1.1	43.6	2.6	1.4	2.4	0.3	6.8	

Start Time	EL CAMINO REAL Southbound				JAMES AVE Westbound				EL CAMINO REAL Northbound				JAMES AVE Eastbound				Int. Total	
	Right	Thru	Left	App. Total	Right	Thru	Left	App. Total	Right	Thru	Left	App. Total	Right	Thru	Left	App. Total		
Peak Hour Analysis From 04:00 PM to 05:45 PM - Peak 1 of 1																		
Peak Hour for Entire Intersection Begins at 05:00 PM																		
05:00 PM	14	309	24	347	21	30	32	83		8	341	22	371	13	13	17	43	844
05:15 PM	21	309	32	362	12	28	27	67		9	327	48	384	20	13	22	55	868
05:30 PM	23	293	25	341	19	31	27	77		6	352	26	384	38	10	22	70	872
05:45 PM	16	337	32	385	20	15	24	59		13	319	26	358	19	16	20	55	857
Total Volume	74	1248	113	1435	72	104	110	286		36	1339	122	1497	90	52	81	223	3441
% App. Total	5.2	87	7.9		25.2	36.4	38.5			2.4	89.4	8.1		40.4	23.3	36.3		
PHF	.804	.926	.883	.932	.857	.839	.859	.861		.692	.951	.635	.975	.592	.813	.920	.796	.987

Traffic Data Service

Campbell, CA
(408) 377-2988
tdsbay@cs.com

File Name : 15PM FINAL
Site Code : 00000015
Start Date : 5/22/2013
Page No : 2

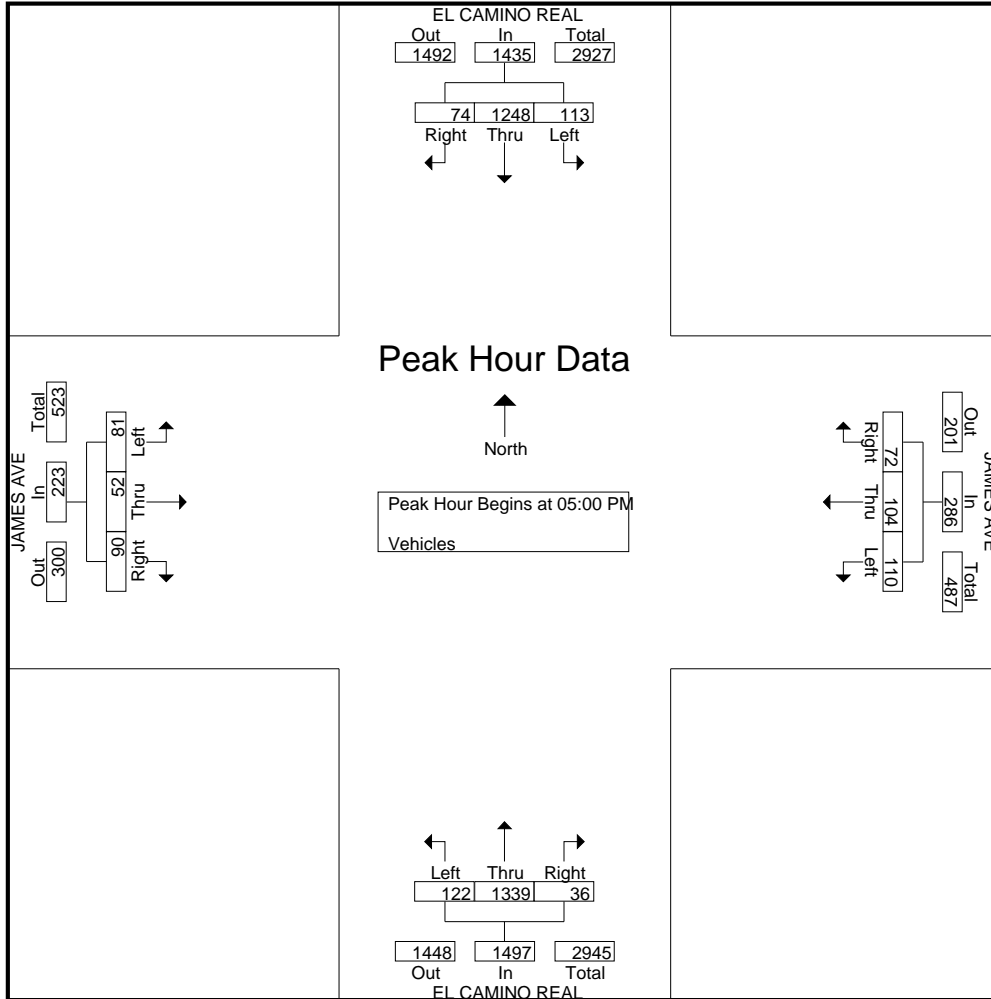

Traffic Data Service

Campbell, CA
 (408) 377-2988
 tdsbay@cs.com

File Name : 15PM FINAL
 Site Code : 00000015
 Start Date : 5/22/2013
 Page No : 1

Groups Printed- Bikes

Start Time	EL CAMINO REAL Southbound					JAMES AVE Westbound					EL CAMINO REAL Northbound					JAMES AVE Eastbound					Int. Total
	Right	Thru	Left	Peds	App. Total	Right	Thru	Left	Peds	App. Total	Right	Thru	Left	Peds	App. Total	Right	Thru	Left	Peds	App. Total	
04:00 PM	0	2	0	0	2	0	0	0	0	0	0	2	0	0	2	0	1	0	0	1	5
04:15 PM	0	1	0	0	1	0	0	0	0	0	0	0	0	0	0	0	0	0	0	0	1
04:30 PM	0	1	0	0	1	0	0	1	0	1	0	1	0	0	1	0	0	0	0	0	3
04:45 PM	0	2	0	0	2	0	0	0	0	0	0	2	0	0	2	1	2	0	0	3	7
Total	0	6	0	0	6	0	0	1	0	1	0	5	0	0	5	1	3	0	0	4	16
05:00 PM	0	2	0	0	2	0	5	0	0	5	0	3	0	0	3	0	0	0	0	0	10
05:15 PM	0	2	0	0	2	0	2	0	0	2	0	0	0	0	0	0	1	0	0	1	5
05:30 PM	0	0	0	0	0	0	3	0	0	3	0	0	0	0	0	0	0	0	0	0	3
05:45 PM	0	1	0	0	1	0	1	0	0	1	0	0	0	0	0	0	0	0	0	0	2
Total	0	5	0	0	5	0	11	0	0	11	0	3	0	0	3	0	1	0	0	1	20
Grand Total	0	11	0	0	11	0	11	1	0	12	0	8	0	0	8	1	4	0	0	5	36
Apprch %	0	100	0	0		0	91.7	8.3	0		0	100	0	0		20	80	0	0		
Total %	0	30.6	0	0	30.6	0	30.6	2.8	0	33.3	0	22.2	0	0	22.2	2.8	11.1	0	0	13.9	

Start Time	EL CAMINO REAL Southbound				JAMES AVE Westbound				EL CAMINO REAL Northbound				JAMES AVE Eastbound				Int. Total
	Right	Thru	Left	App. Total	Right	Thru	Left	App. Total	Right	Thru	Left	App. Total	Right	Thru	Left	App. Total	
Peak Hour Analysis From 04:00 PM to 05:45 PM - Peak 1 of 1																	
Peak Hour for Entire Intersection Begins at 04:30 PM																	
04:30 PM	0	1	0	1	0	0	1	1	0	1	0	1	0	0	0	0	3
04:45 PM	0	2	0	2	0	0	0	0	0	2	0	2	1	2	0	3	7
05:00 PM	0	2	0	2	0	5	0	5	0	3	0	3	0	0	0	0	10
05:15 PM	0	2	0	2	0	2	0	2	0	0	0	0	0	1	0	1	5
Total Volume	0	7	0	7	0	7	1	8	0	6	0	6	1	3	0	4	25
% App. Total	0	100	0		0	87.5	12.5		0	100	0		25	75	0		
PHF	.000	.875	.000	.875	.000	.350	.250	.400	.000	.500	.000	.500	.250	.375	.000	.333	.625

Traffic Data Service

Campbell, CA
(408) 377-2988
tdsbay@cs.com

File Name : 15PM FINAL
Site Code : 00000015
Start Date : 5/22/2013
Page No : 2

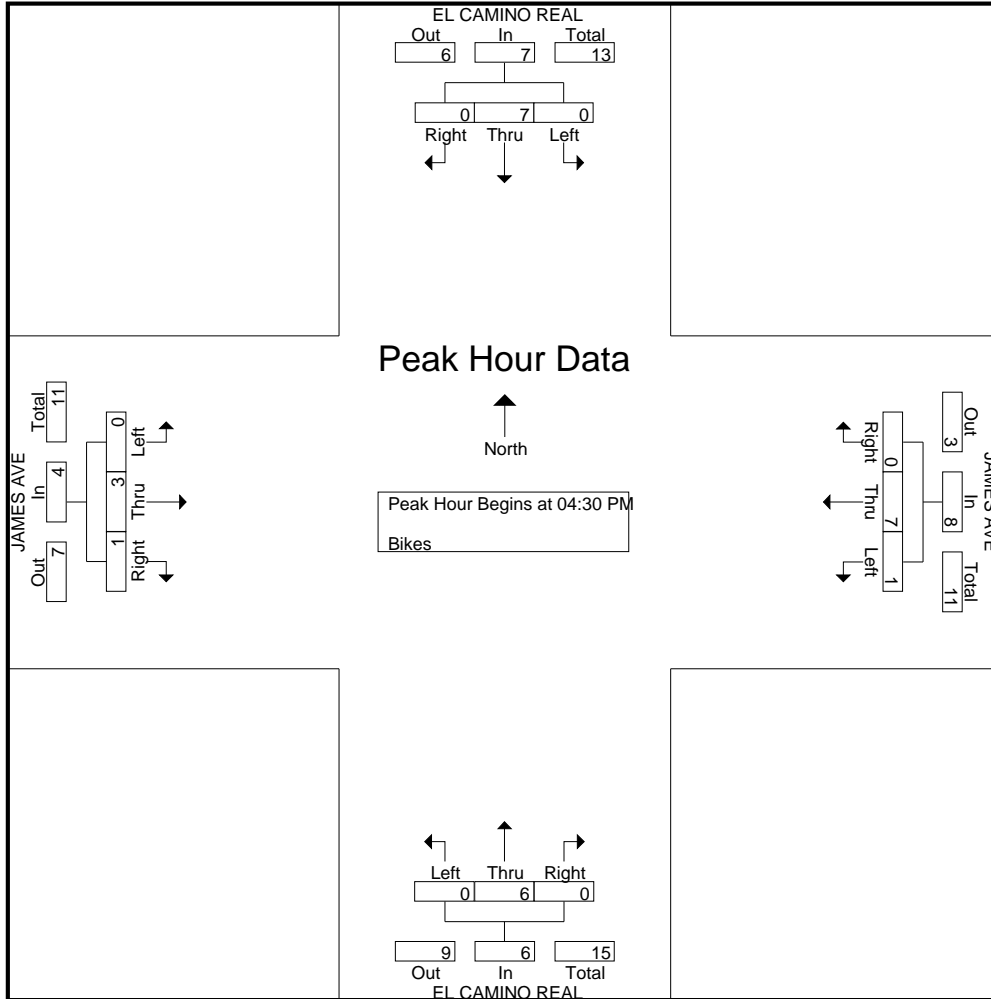

Traffic Data Service

Campbell, CA
 (408) 377-2988
 tdsbay@cs.com

File Name : 70AM FINAL
 Site Code : 00000070
 Start Date : 6/6/2013
 Page No : 1

Groups Printed- Vehicles

Start Time	EL CAMINO REAL Southbound					FAIR OAKS LN Westbound					EL CAMINO REAL Northbound					ATHERTON AVE Eastbound					Int. Total
	Right	Thru	Left	Peds	App. Total	Right	Thru	Left	Peds	App. Total	Right	Thru	Left	Peds	App. Total	Right	Thru	Left	Peds	App. Total	
07:00 AM	20	221	11	1	253	8	18	5	0	31	3	72	8	0	83	12	9	5	0	26	393
07:15 AM	23	302	5	0	330	15	29	9	0	53	9	95	9	0	113	18	11	5	0	34	530
07:30 AM	50	395	21	0	466	16	44	18	0	78	3	129	10	0	142	28	20	12	1	61	747
07:45 AM	65	421	20	0	506	19	41	22	0	82	7	155	17	0	179	31	20	27	0	78	845
Total	158	1339	57	1	1555	58	132	54	0	244	22	451	44	0	517	89	60	49	1	199	2515
08:00 AM	40	390	13	1	444	14	30	19	0	63	9	177	18	0	204	22	18	21	1	62	773
08:15 AM	37	429	16	0	482	9	32	20	1	62	7	197	12	0	216	38	15	33	2	88	848
08:30 AM	28	442	15	0	485	20	24	16	0	60	5	185	25	0	215	27	21	29	2	79	839
08:45 AM	25	385	12	1	423	18	27	14	3	62	9	177	16	0	202	30	29	30	2	91	778
Total	130	1646	56	2	1834	61	113	69	4	247	30	736	71	0	837	117	83	113	7	320	3238
Grand Total	288	2985	113	3	3389	119	245	123	4	491	52	1187	115	0	1354	206	143	162	8	519	5753
Apprch %	8.5	88.1	3.3	0.1		24.2	49.9	25.1	0.8		3.8	87.7	8.5	0		39.7	27.6	31.2	1.5		
Total %	5	51.9	2	0.1	58.9	2.1	4.3	2.1	0.1	8.5	0.9	20.6	2	0	23.5	3.6	2.5	2.8	0.1	9	

Start Time	EL CAMINO REAL Southbound					FAIR OAKS LN Westbound					EL CAMINO REAL Northbound					ATHERTON AVE Eastbound					Int. Total
	Right	Thru	Left	Peds	App. Total	Right	Thru	Left	Peds	App. Total	Right	Thru	Left	Peds	App. Total	Right	Thru	Left	Peds	App. Total	
07:45 AM	65	421	20		506	19	41	22		82	7	155	17		179	31	20	27		78	845
08:00 AM	40	390	13		443	14	30	19		63	9	177	18		204	22	18	21		61	771
08:15 AM	37	429	16		482	9	32	20		61	7	197	12		216	38	15	33		86	845
08:30 AM	28	442	15		485	20	24	16		60	5	185	25		215	27	21	29		77	837
Total Volume	170	1682	64		1916	62	127	77		266	28	714	72		814	118	74	110		302	3298
% App. Total	8.9	87.8	3.3			23.3	47.7	28.9			3.4	87.7	8.8			39.1	24.5	36.4			
PHF	.654	.951	.800		.947	.775	.774	.875		.811	.778	.906	.720		.942	.776	.881	.833		.878	.976

Peak Hour Analysis From 07:00 AM to 08:45 AM - Peak 1 of 1

Peak Hour for Entire Intersection Begins at 07:45 AM

Traffic Data Service

Campbell, CA
 (408) 377-2988
 tdsbay@cs.com

File Name : 70AM FINAL
 Site Code : 00000070
 Start Date : 6/6/2013
 Page No : 2

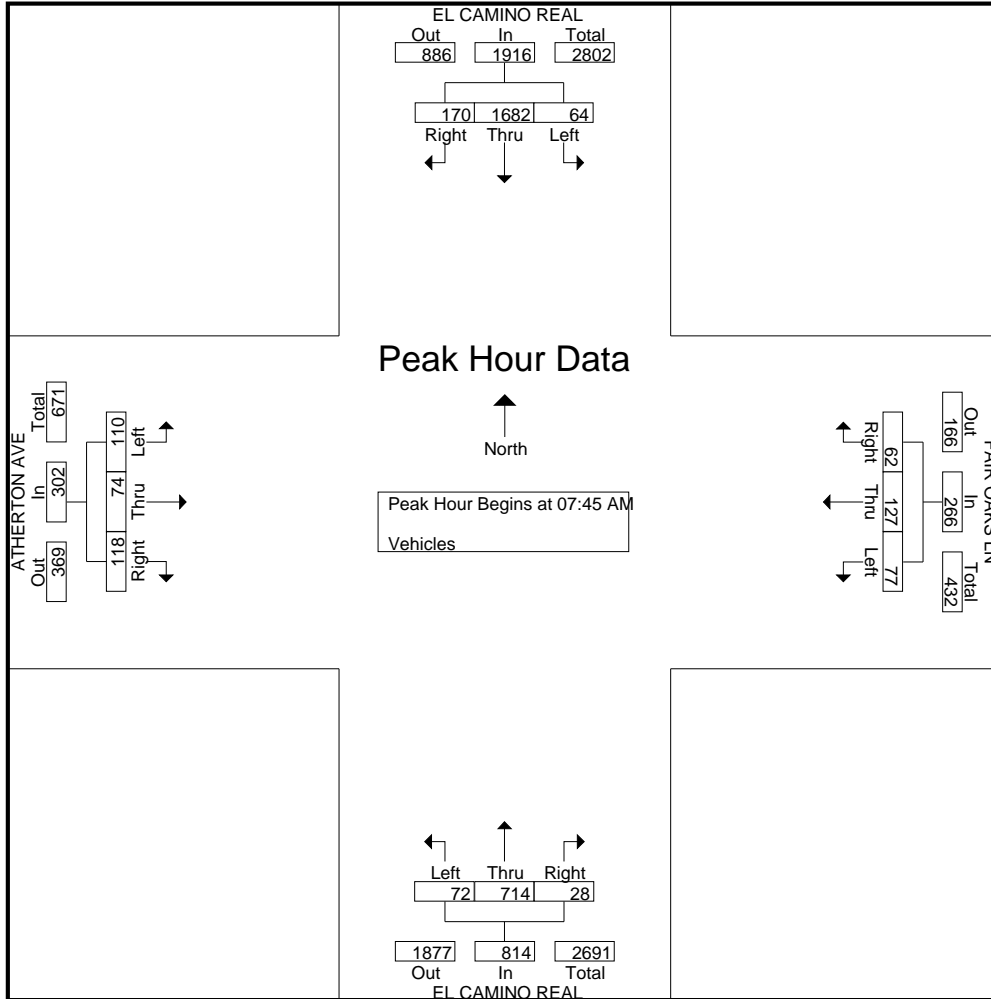

Traffic Data Service

Campbell, CA
 (408) 377-2988
 tdsbay@cs.com

File Name : 70AM FINAL
 Site Code : 00000070
 Start Date : 6/6/2013
 Page No : 1

Groups Printed- Bikes

Start Time	EL CAMINO REAL Southbound					FAIR OAKS LN Westbound					EL CAMINO REAL Northbound					ATHERTON AVE Eastbound					Int. Total
	Right	Thru	Left	Peds	App. Total	Right	Thru	Left	Peds	App. Total	Right	Thru	Left	Peds	App. Total	Right	Thru	Left	Peds	App. Total	
07:00 AM	0	1	0	0	1	0	0	0	0	0	0	0	1	0	1	0	1	0	0	1	3
07:15 AM	0	2	0	0	2	0	0	0	0	0	0	0	0	0	0	1	1	0	0	2	4
07:30 AM	0	1	0	0	1	0	0	0	0	0	0	0	0	0	0	0	1	0	0	1	2
07:45 AM	0	1	0	0	1	0	0	0	0	0	0	0	0	0	0	0	0	0	0	0	1
Total	0	5	0	0	5	0	0	0	0	0	0	0	1	0	1	1	3	0	0	4	10
08:00 AM	0	1	0	0	1	0	0	0	0	0	0	1	0	0	1	0	0	0	0	0	2
08:15 AM	0	2	0	0	2	0	0	0	0	0	0	2	0	0	2	0	0	0	0	0	4
08:30 AM	1	8	0	0	9	0	0	0	0	0	0	1	0	0	1	0	0	0	0	0	10
08:45 AM	0	1	0	0	1	0	0	0	0	0	0	1	0	0	1	0	0	0	0	0	2
Total	1	12	0	0	13	0	0	0	0	0	0	5	0	0	5	0	0	0	0	0	18
Grand Total	1	17	0	0	18	0	0	0	0	0	0	5	1	0	6	1	3	0	0	4	28
Apprch %	5.6	94.4	0	0		0	0	0	0		0	83.3	16.7	0		25	75	0	0		
Total %	3.6	60.7	0	0	64.3	0	0	0	0		0	17.9	3.6	0	21.4	3.6	10.7	0	0	14.3	

Start Time	EL CAMINO REAL Southbound					FAIR OAKS LN Westbound					EL CAMINO REAL Northbound					ATHERTON AVE Eastbound					Int. Total
	Right	Thru	Left	Peds	App. Total	Right	Thru	Left	Peds	App. Total	Right	Thru	Left	Peds	App. Total	Right	Thru	Left	Peds	App. Total	
08:00 AM	0	1	0	0	1	0	0	0	0	0	0	1	0	0	1	0	0	0	0	0	2
08:15 AM	0	2	0	0	2	0	0	0	0	0	0	2	0	0	2	0	0	0	0	0	4
08:30 AM	1	8	0	0	9	0	0	0	0	0	0	1	0	0	1	0	0	0	0	0	10
08:45 AM	0	1	0	0	1	0	0	0	0	0	0	1	0	0	1	0	0	0	0	0	2
Total Volume	1	12	0	0	13	0	0	0	0	0	0	5	0	0	5	0	0	0	0	0	18
% App. Total	7.7	92.3	0	0		0	0	0	0		0	100	0	0		0	0	0	0		
PHF	.250	.375	.000	.000	.361	.000	.000	.000	.000	.000	.000	.625	.000	.000	.625	.000	.000	.000	.000	.000	.450

Peak Hour Analysis From 07:00 AM to 08:45 AM - Peak 1 of 1

Peak Hour for Entire Intersection Begins at 08:00 AM

Traffic Data Service

Campbell, CA
 (408) 377-2988
 tdsbay@cs.com

File Name : 70AM FINAL
 Site Code : 00000070
 Start Date : 6/6/2013
 Page No : 2

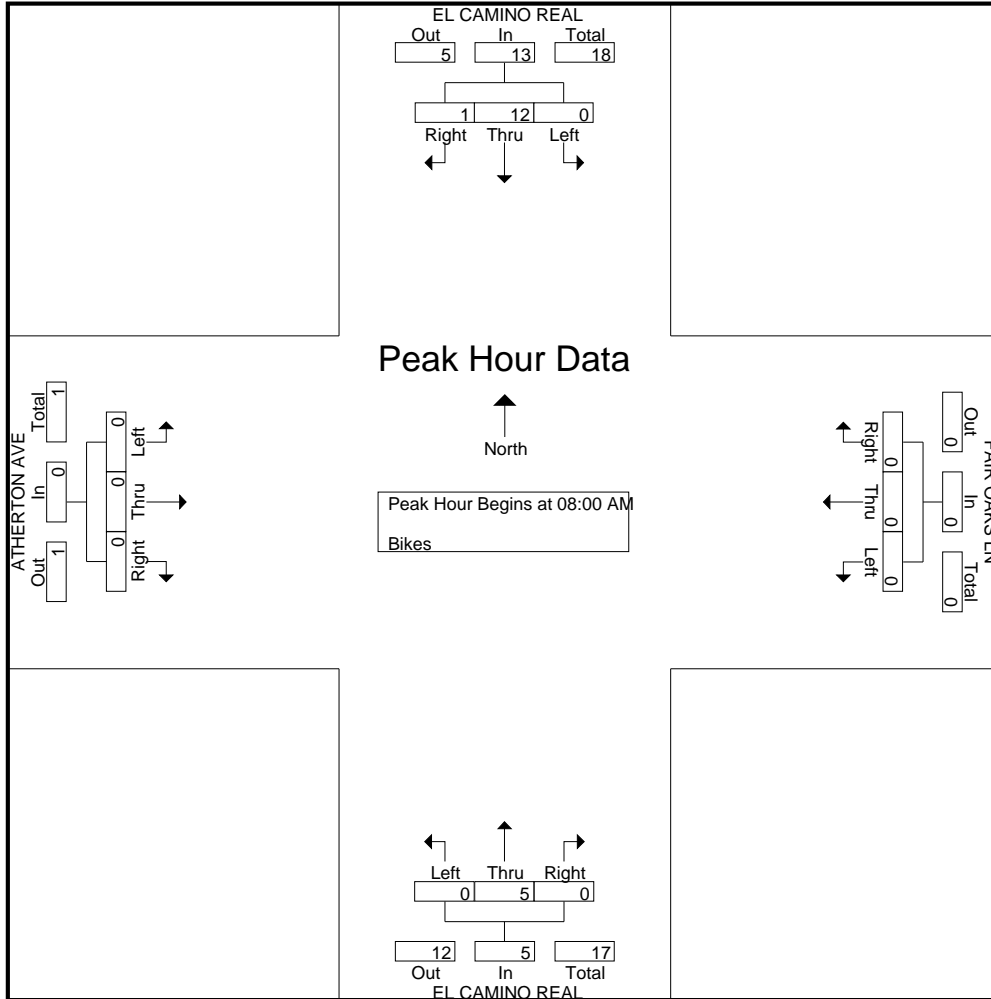

Traffic Data Service

Campbell, CA
 (408) 377-2988
 tdsbay@cs.com

File Name : 70PM FINAL
 Site Code : 00000070
 Start Date : 6/6/2013
 Page No : 1

Groups Printed- Vehicles

Start Time	EL CAMINO REAL Southbound					FAIR OAKS LN Westbound					EL CAMINO REAL Northbound					ATHERTON AVE Eastbound					Int. Total
	Right	Thru	Left	Peds	App. Total	Right	Thru	Left	Peds	App. Total	Right	Thru	Left	Peds	App. Total	Right	Thru	Left	Peds	App. Total	
04:00 PM	13	254	3	0	270	15	22	7	0	44	17	459	14	0	490	13	38	34	2	87	891
04:15 PM	20	265	3	0	288	26	24	19	0	69	14	365	29	0	408	17	24	47	3	91	856
04:30 PM	12	256	4	0	272	5	39	10	0	54	22	431	25	0	478	13	31	26	1	71	875
04:45 PM	14	294	18	3	329	18	14	11	0	43	13	447	32	0	492	20	11	36	0	67	931
Total	59	1069	28	3	1159	64	99	47	0	210	66	1702	100	0	1868	63	104	143	6	316	3553
05:00 PM	23	271	5	0	299	20	26	8	0	54	10	417	46	0	473	15	19	32	2	68	894
05:15 PM	23	254	9	0	286	20	26	8	0	54	10	453	45	0	508	13	28	31	0	72	920
05:30 PM	19	291	12	0	322	13	30	18	2	63	6	396	34	0	436	10	12	21	1	44	865
05:45 PM	17	233	11	0	261	12	30	9	0	51	5	416	38	0	459	21	26	16	2	65	836
Total	82	1049	37	0	1168	65	112	43	2	222	31	1682	163	0	1876	59	85	100	5	249	3515
Grand Total	141	2118	65	3	2327	129	211	90	2	432	97	3384	263	0	3744	122	189	243	11	565	7068
Apprch %	6.1	91	2.8	0.1		29.9	48.8	20.8	0.5		2.6	90.4	7	0		21.6	33.5	43	1.9		
Total %	2	30	0.9	0	32.9	1.8	3	1.3	0	6.1	1.4	47.9	3.7	0	53	1.7	2.7	3.4	0.2		8

Start Time	EL CAMINO REAL Southbound					FAIR OAKS LN Westbound					EL CAMINO REAL Northbound					ATHERTON AVE Eastbound					Int. Total
	Right	Thru	Left	Peds	App. Total	Right	Thru	Left	Peds	App. Total	Right	Thru	Left	Peds	App. Total	Right	Thru	Left	Peds	App. Total	
04:30 PM	12	256	4		272	5	39	10		54	22	431	25		478	13	31	26		70	874
04:45 PM	14	294	18		326	18	14	11		43	13	447	32		492	20	11	36		67	928
05:00 PM	23	271	5		299	20	26	8		54	10	417	46		473	15	19	32		66	892
05:15 PM	23	254	9		286	20	26	8		54	10	453	45		508	13	28	31		72	920
Total Volume	72	1075	36		1183	63	105	37		205	55	1748	148		1951	61	89	125		275	3614
% App. Total	6.1	90.9	3			30.7	51.2	18			2.8	89.6	7.6			22.2	32.4	45.5			
PHF	.783	.914	.500		.907	.788	.673	.841		.949	.625	.965	.804		.960	.763	.718	.868		.955	.974

Peak Hour Analysis From 04:00 PM to 05:45 PM - Peak 1 of 1

Peak Hour for Entire Intersection Begins at 04:30 PM

Traffic Data Service

Campbell, CA
 (408) 377-2988
 tdsbay@cs.com

File Name : 70PM FINAL
 Site Code : 00000070
 Start Date : 6/6/2013
 Page No : 2

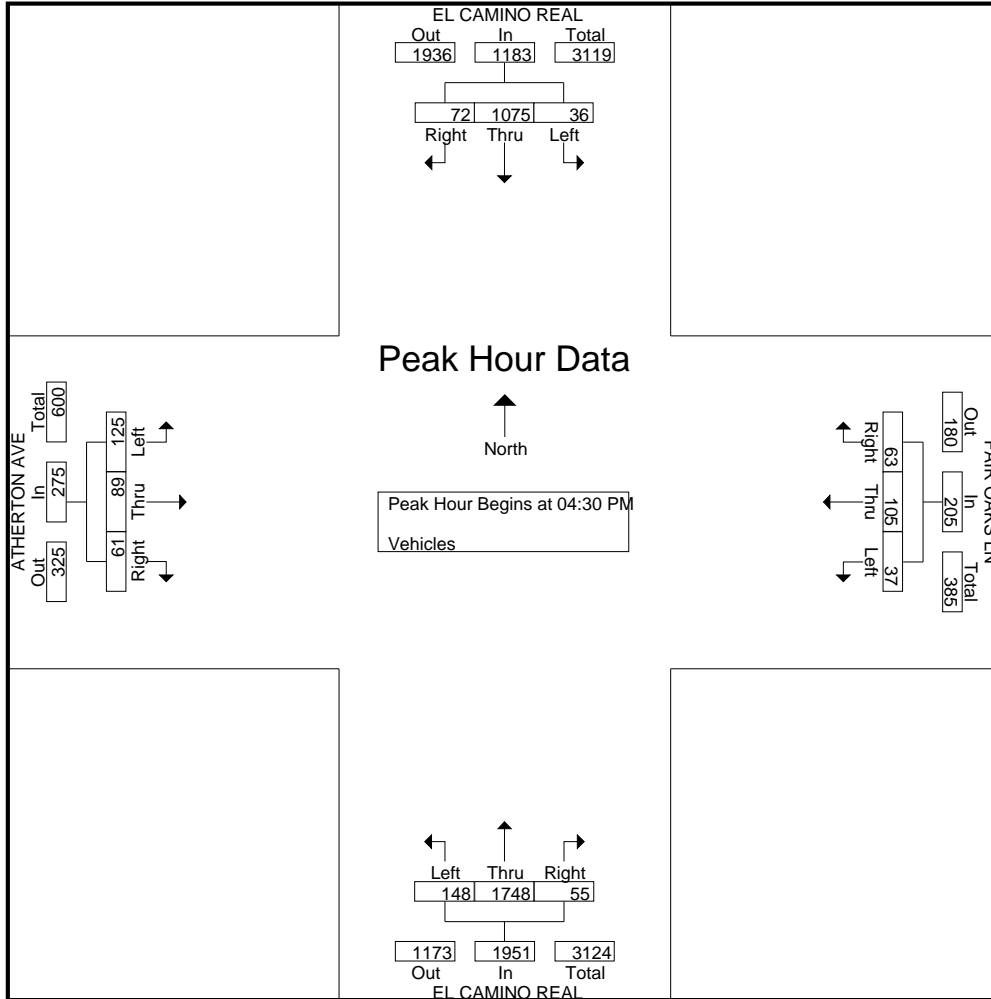

Traffic Data Service

Campbell, CA
(408) 377-2988
tdsbay@cs.com

File Name : 70PM FINAL
Site Code : 00000070
Start Date : 6/6/2013
Page No : 1

Groups Printed- Bikes

Start Time	EL CAMINO REAL Southbound					FAIR OAKS LN Westbound					EL CAMINO REAL Northbound					ATHERTON AVE Eastbound					Int. Total
	Right	Thru	Left	Peds	App. Total	Right	Thru	Left	Peds	App. Total	Right	Thru	Left	Peds	App. Total	Right	Thru	Left	Peds	App. Total	
04:00 PM	0	0	0	0	0	0	0	0	0	0	1	1	0	0	2	0	2	1	0	3	5
04:15 PM	0	0	0	0	0	0	0	0	0	0	0	3	0	0	3	0	0	0	0	0	3
04:30 PM	0	0	0	0	0	1	0	0	0	1	0	1	0	0	1	0	0	0	0	0	2
04:45 PM	0	0	0	0	0	0	0	0	0	0	0	2	0	0	2	0	0	1	0	1	3
Total	0	0	0	0	0	1	0	0	0	1	1	7	0	0	8	0	2	2	0	4	13
05:00 PM	0	2	0	0	2	0	1	0	0	1	0	1	0	0	1	0	0	0	0	0	4
05:15 PM	0	0	0	0	0	0	0	0	0	0	0	5	0	0	5	0	0	0	0	0	5
05:30 PM	0	1	0	0	1	0	0	0	0	0	0	2	0	0	2	0	0	0	0	0	3
05:45 PM	0	1	0	0	1	0	0	0	0	0	0	1	0	0	1	0	0	0	0	0	2
Total	0	4	0	0	4	0	1	0	0	1	0	9	0	0	9	0	0	0	0	0	14
Grand Total	0	4	0	0	4	1	1	0	0	2	1	16	0	0	17	0	2	2	0	4	27
Apprch %	0	100	0	0		50	50	0	0		5.9	94.1	0	0		0	50	50	0		
Total %	0	14.8	0	0	14.8	3.7	3.7	0	0	7.4	3.7	59.3	0	0	63	0	7.4	7.4	0	14.8	

Start Time	EL CAMINO REAL Southbound				FAIR OAKS LN Westbound				EL CAMINO REAL Northbound				ATHERTON AVE Eastbound				Int. Total
	Right	Thru	Left	App. Total	Right	Thru	Left	App. Total	Right	Thru	Left	App. Total	Right	Thru	Left	App. Total	
Peak Hour Analysis From 04:00 PM to 05:45 PM - Peak 1 of 1																	
Peak Hour for Entire Intersection Begins at 04:45 PM																	
04:45 PM	0	0	0	0	0	0	0	0	0	2	0	2	0	0	1	1	3
05:00 PM	0	2	0	2	0	1	0	1	0	1	0	1	0	0	0	0	4
05:15 PM	0	0	0	0	0	0	0	0	0	5	0	5	0	0	0	0	5
05:30 PM	0	1	0	1	0	0	0	0	0	2	0	2	0	0	0	0	3
Total Volume	0	3	0	3	0	1	0	1	0	10	0	10	0	0	1	1	15
% App. Total	0	100	0		0	100	0		0	100	0		0	0	100		
PHF	.000	.375	.000	.375	.000	.250	.000	.250	.000	.500	.000	.500	.000	.000	.250	.250	.750

Traffic Data Service

Campbell, CA

(408) 377-2988

tdsbay@cs.com

File Name : 70PM FINAL

Site Code : 00000070

Start Date : 6/6/2013

Page No : 2

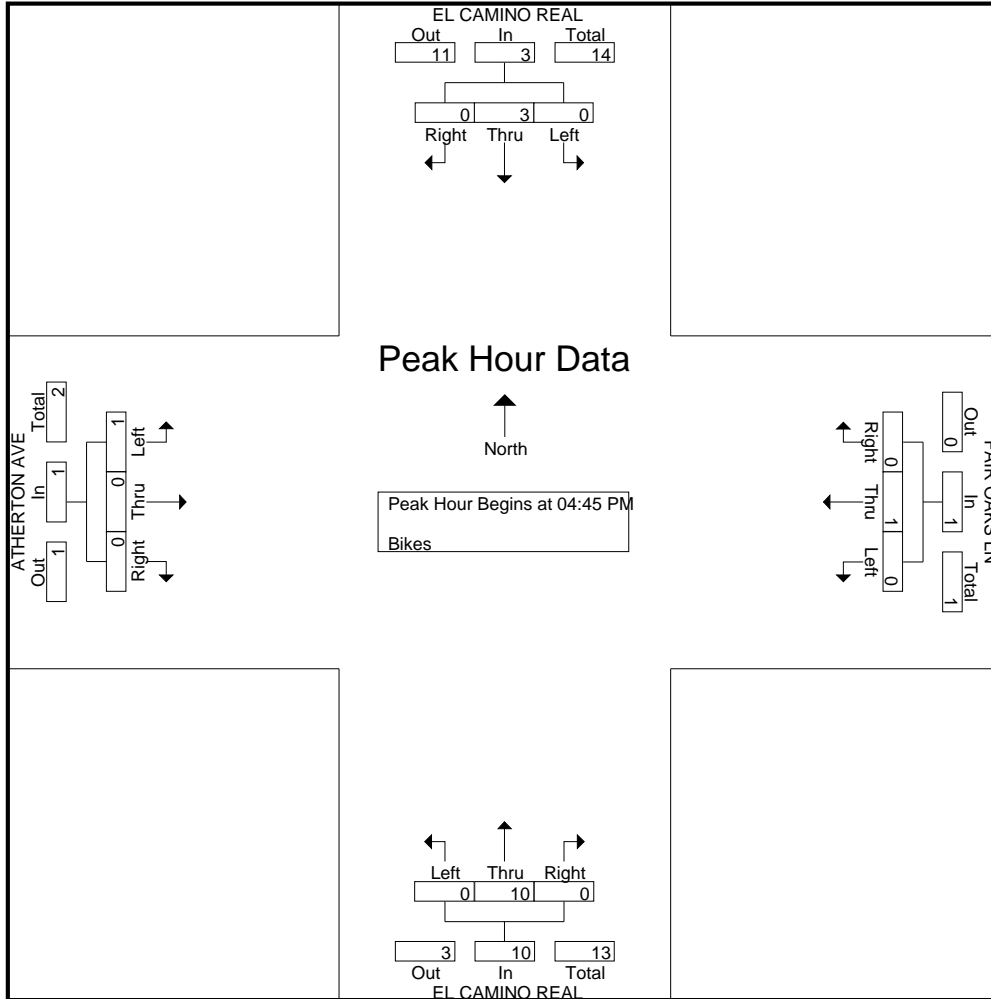

Traffic Data Service

Campbell, CA
(408) 377-2988
tdsbay@cs.com

File Name : 71AM FINAL
Site Code : 00000071
Start Date : 6/6/2013
Page No : 2

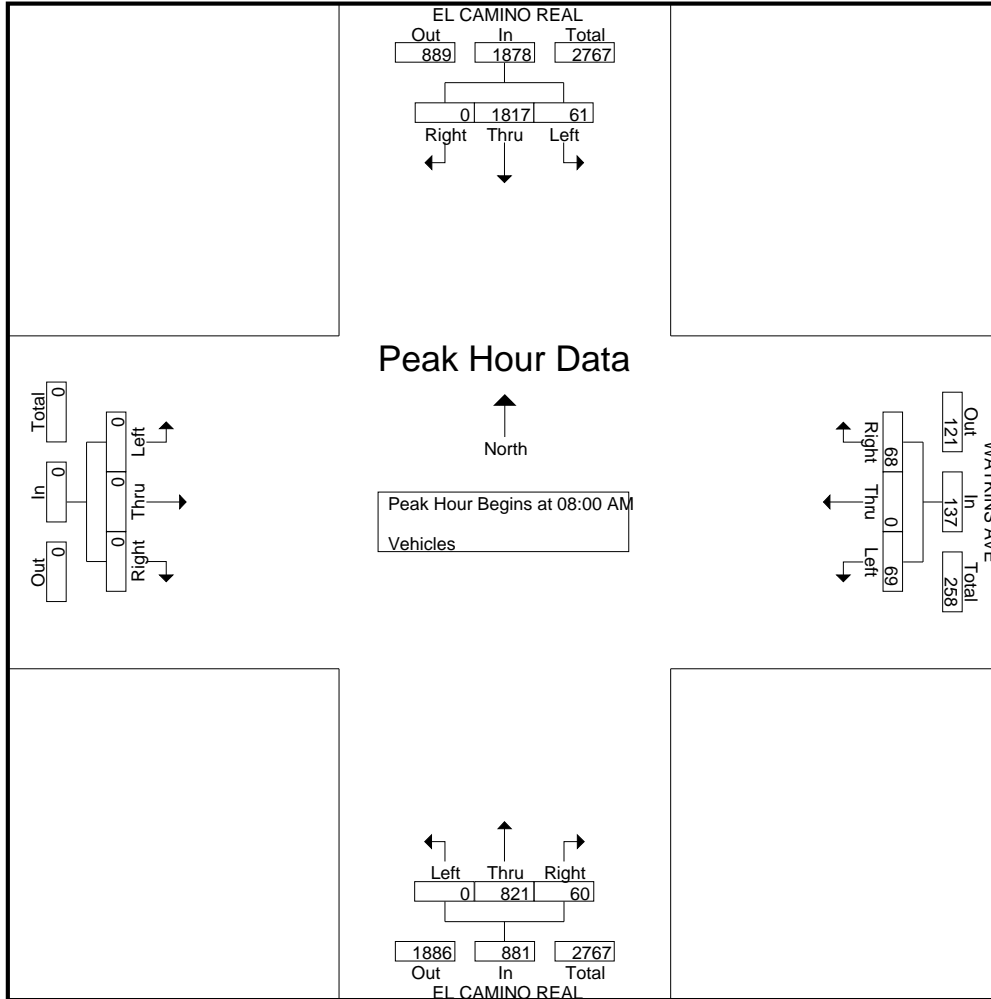

Traffic Data Service

Campbell, CA
 (408) 377-2988
 tdsbay@cs.com

File Name : 71AM FINAL
 Site Code : 00000071
 Start Date : 6/6/2013
 Page No : 1

Groups Printed- Bikes

Start Time	EL CAMINO REAL Southbound					WATKINS AVE Westbound					EL CAMINO REAL Northbound					Eastbound					Int. Total
	Right	Thru	Left	Peds	App. Total	Right	Thru	Left	Peds	App. Total	Right	Thru	Left	Peds	App. Total	Right	Thru	Left	Peds	App. Total	
07:00 AM	0	0	0	0	0	0	0	0	0	0	0	1	0	0	1	0	0	0	0	0	0
07:15 AM	0	0	0	0	0	0	0	0	0	0	0	0	0	0	0	0	0	0	0	0	0
07:30 AM	0	0	0	0	0	0	0	0	0	0	0	0	0	0	0	0	0	0	0	0	0
07:45 AM	0	1	0	0	1	0	0	0	0	0	0	2	0	0	2	0	0	0	0	0	0
Total	0	1	0	0	1	0	0	0	0	0	0	3	0	0	3	0	0	0	0	0	4
08:00 AM	0	1	0	0	1	1	0	0	0	1	1	1	0	0	2	0	0	0	0	0	0
08:15 AM	0	3	0	0	3	0	0	0	0	0	0	1	0	0	1	0	0	0	0	0	0
08:30 AM	0	0	0	0	0	0	0	0	0	0	0	2	0	0	2	0	0	0	0	0	0
08:45 AM	0	0	0	0	0	0	0	0	0	0	1	1	0	0	2	0	0	0	0	0	0
Total	0	4	0	0	4	1	0	0	0	1	2	5	0	0	7	0	0	0	0	0	12
Grand Total	0	5	0	0	5	1	0	0	0	1	2	8	0	0	10	0	0	0	0	0	16
Apprch %	0	100	0	0		100	0	0	0		20	80	0	0		0	0	0	0		
Total %	0	31.2	0	0	31.2	6.2	0	0	0	6.2	12.5	50	0	0	62.5	0	0	0	0	0	

Start Time	EL CAMINO REAL Southbound					WATKINS AVE Westbound					EL CAMINO REAL Northbound					Eastbound					Int. Total
	Right	Thru	Left	Peds	App. Total	Right	Thru	Left	Peds	App. Total	Right	Thru	Left	Peds	App. Total	Right	Thru	Left	Peds	App. Total	
Peak Hour Analysis From 07:00 AM to 08:45 AM - Peak 1 of 1																					
Peak Hour for Entire Intersection Begins at 07:45 AM																					
07:45 AM	0	1	0	0	1	0	0	0	0	0	0	2	0	0	2	0	0	0	0	0	0
08:00 AM	0	1	0	0	1	1	0	0	0	1	1	1	0	0	2	0	0	0	0	0	0
08:15 AM	0	3	0	0	3	0	0	0	0	0	0	1	0	0	1	0	0	0	0	0	0
08:30 AM	0	0	0	0	0	0	0	0	0	0	0	2	0	0	2	0	0	0	0	0	0
Total Volume	0	5	0	0	5	1	0	0	0	1	1	6	0	0	7	0	0	0	0	0	13
% App. Total	0	100	0	0		100	0	0	0		14.3	85.7	0	0		0	0	0	0		
PHF	.000	.417	.000	.000	.417	.250	.000	.000	.000	.250	.250	.750	.000	.000	.875	.000	.000	.000	.000	.000	.813

Traffic Data Service

Campbell, CA

(408) 377-2988

tdsbay@cs.com

File Name : 71AM FINAL

Site Code : 00000071

Start Date : 6/6/2013

Page No : 2

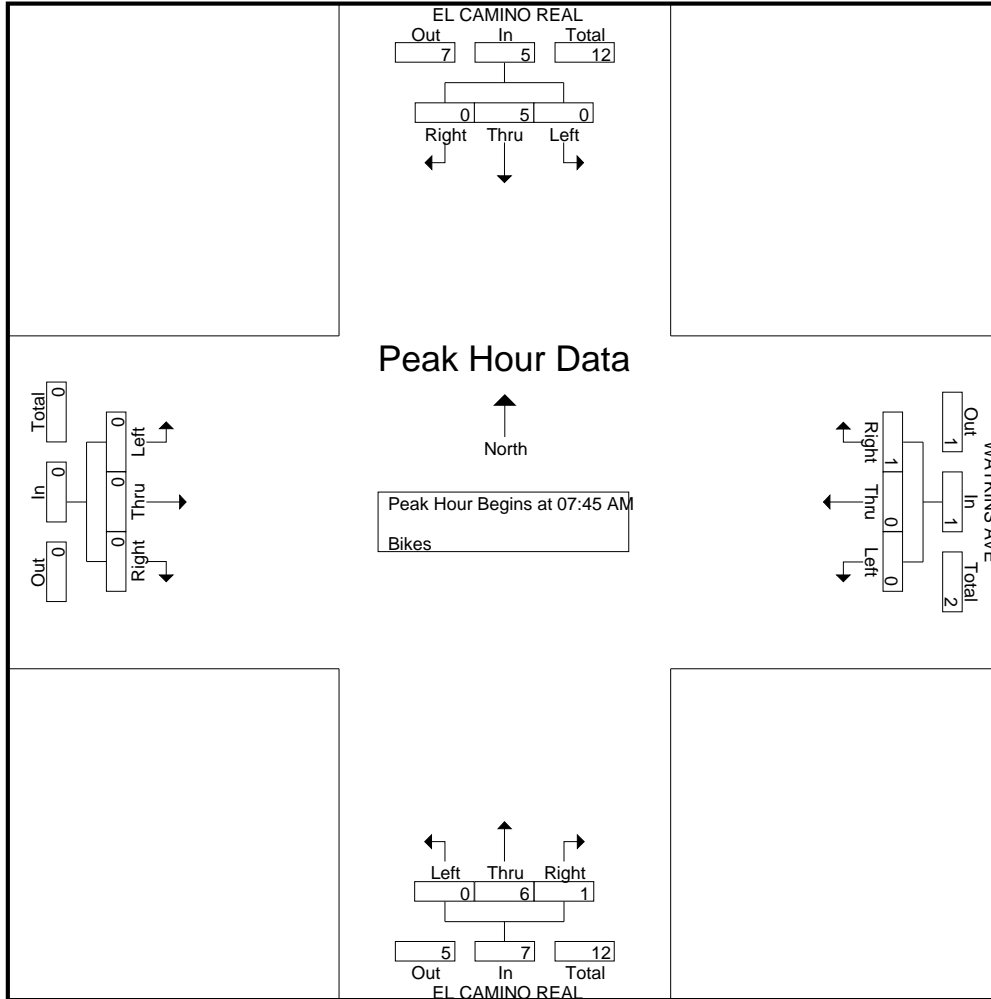

Traffic Data Service

Campbell, CA
 (408) 377-2988
 tdsbay@cs.com

File Name : 71PM FINAL
 Site Code : 00000071
 Start Date : 6/6/2013
 Page No : 1

Groups Printed- Vehicles

Start Time	EL CAMINO REAL Southbound					WATKINS AVE Westbound					EL CAMINO REAL Northbound					Eastbound					Int. Total
	Right	Thru	Left	Peds	App. Total	Right	Thru	Left	Peds	App. Total	Right	Thru	Left	Peds	App. Total	Right	Thru	Left	Peds	App. Total	
04:00 PM	0	254	15	0	269	24	0	4	1	29	26	415	0	0	441	0	0	0	0	0	739
04:15 PM	0	298	10	0	308	38	0	2	3	43	24	406	0	0	430	0	0	0	0	0	781
04:30 PM	0	266	9	0	275	26	0	4	0	30	13	451	0	0	464	0	0	0	0	0	769
04:45 PM	0	312	10	0	322	24	0	0	3	27	7	478	0	0	485	0	0	0	0	0	834
Total	0	1130	44	0	1174	112	0	10	7	129	70	1750	0	0	1820	0	0	0	0	0	3123
05:00 PM	0	292	7	0	299	27	0	2	1	30	12	491	0	0	503	0	0	0	0	0	832
05:15 PM	0	274	3	0	277	21	0	3	3	27	15	488	0	0	503	0	0	0	0	0	807
05:30 PM	0	289	8	0	297	14	0	3	1	18	11	434	0	0	445	0	0	0	0	0	760
05:45 PM	0	272	5	0	277	21	0	3	3	27	8	463	0	0	471	0	0	0	0	0	775
Total	0	1127	23	0	1150	83	0	11	8	102	46	1876	0	0	1922	0	0	0	0	0	3174
Grand Total	0	2257	67	0	2324	195	0	21	15	231	116	3626	0	0	3742	0	0	0	0	0	6297
Apprch %	0	97.1	2.9	0		84.4	0	9.1	6.5		3.1	96.9	0	0		0	0	0	0		
Total %	0	35.8	1.1	0	36.9	3.1	0	0.3	0.2	3.7	1.8	57.6	0	0	59.4	0	0	0	0	0	

Start Time	EL CAMINO REAL Southbound				WATKINS AVE Westbound				EL CAMINO REAL Northbound				Eastbound				Int. Total
	Right	Thru	Left	App. Total	Right	Thru	Left	App. Total	Right	Thru	Left	App. Total	Right	Thru	Left	App. Total	
Peak Hour Analysis From 04:00 PM to 05:45 PM - Peak 1 of 1																	
Peak Hour for Entire Intersection Begins at 04:30 PM																	
04:30 PM	0	266	9	275	26	0	4	30	13	451	0	464	0	0	0	0	769
04:45 PM	0	312	10	322	24	0	0	24	7	478	0	485	0	0	0	0	831
05:00 PM	0	292	7	299	27	0	2	29	12	491	0	503	0	0	0	0	831
05:15 PM	0	274	3	277	21	0	3	24	15	488	0	503	0	0	0	0	804
Total Volume	0	1144	29	1173	98	0	9	107	47	1908	0	1955	0	0	0	0	3235
% App. Total	0	97.5	2.5		91.6	0	8.4		2.4	97.6	0		0	0	0		
PHF	.000	.917	.725	.911	.907	.000	.563	.892	.783	.971	.000	.972	.000	.000	.000	.000	.973

Traffic Data Service

Campbell, CA
(408) 377-2988
tdsbay@cs.com

File Name : 71PM FINAL
Site Code : 00000071
Start Date : 6/6/2013
Page No : 2

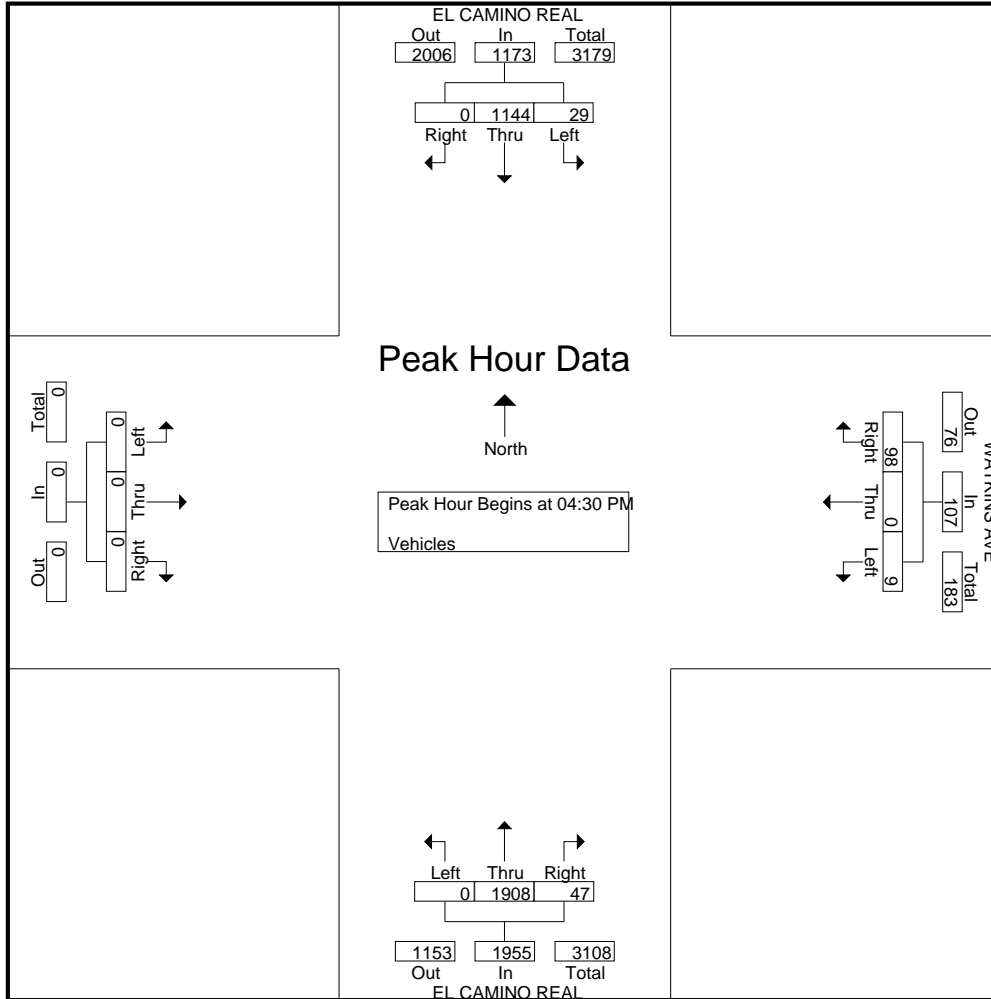

Traffic Data Service

Campbell, CA
 (408) 377-2988
 tdsbay@cs.com

File Name : 71PM FINAL
 Site Code : 00000071
 Start Date : 6/6/2013
 Page No : 1

Groups Printed- Bikes

Start Time	EL CAMINO REAL Southbound					WATKINS AVE Westbound					EL CAMINO REAL Northbound					Eastbound					Int. Total
	Right	Thru	Left	Peds	App. Total	Right	Thru	Left	Peds	App. Total	Right	Thru	Left	Peds	App. Total	Right	Thru	Left	Peds	App. Total	
04:00 PM	0	1	0	0	1	0	0	0	0	0	0	0	0	0	0	0	0	0	0	0	0
04:15 PM	0	1	0	0	1	0	0	0	0	0	0	0	0	0	0	0	0	0	0	0	0
04:30 PM	0	1	0	0	1	0	0	0	0	0	0	1	0	0	1	0	0	0	0	0	0
04:45 PM	0	0	0	0	0	0	0	0	0	0	0	1	0	0	1	0	0	0	0	0	0
Total	0	3	0	0	3	0	0	0	0	0	0	2	0	0	2	0	0	0	0	0	5
05:00 PM	0	1	0	0	1	0	0	0	0	0	0	0	0	0	0	0	0	0	0	0	0
05:15 PM	0	0	0	0	0	0	0	0	0	0	0	3	0	0	3	0	0	0	0	0	0
05:30 PM	0	1	0	0	1	0	0	0	0	0	0	2	0	0	2	0	0	0	0	0	0
05:45 PM	0	0	0	0	0	0	0	0	0	0	0	1	0	0	1	0	0	0	0	0	0
Total	0	2	0	0	2	0	0	0	0	0	0	6	0	0	6	0	0	0	0	0	8
Grand Total	0	5	0	0	5	0	0	0	0	0	0	8	0	0	8	0	0	0	0	0	13
Apprch %	0	100	0	0		0	0	0	0		0	100	0	0		0	0	0	0		
Total %	0	38.5	0	0	38.5	0	0	0	0	0	0	61.5	0	0	61.5	0	0	0	0	0	

Start Time	EL CAMINO REAL Southbound				WATKINS AVE Westbound				EL CAMINO REAL Northbound				Eastbound				Int. Total
	Right	Thru	Left	App. Total	Right	Thru	Left	App. Total	Right	Thru	Left	App. Total	Right	Thru	Left	App. Total	
04:45 PM	0	0	0	0	0	0	0	0	0	1	0	1	0	0	0	0	
05:00 PM	0	1	0	1	0	0	0	0	0	0	0	0	0	0	0	0	
05:15 PM	0	0	0	0	0	0	0	0	0	3	0	3	0	0	0	0	
05:30 PM	0	1	0	1	0	0	0	0	0	2	0	2	0	0	0	0	
Total Volume	0	2	0	2	0	0	0	0	0	6	0	6	0	0	0	0	
% App. Total	0	100	0		0	0	0		0	100	0		0	0	0		
PHF	.000	.500	.000	.500	.000	.000	.000	.000	.000	.500	.000	.500	.000	.000	.000	.000	

Peak Hour Analysis From 04:00 PM to 05:45 PM - Peak 1 of 1

Peak Hour for Entire Intersection Begins at 04:45 PM

Traffic Data Service

Campbell, CA

(408) 377-2988

tdsbay@cs.com

File Name : 71PM FINAL

Site Code : 00000071

Start Date : 6/6/2013

Page No : 2

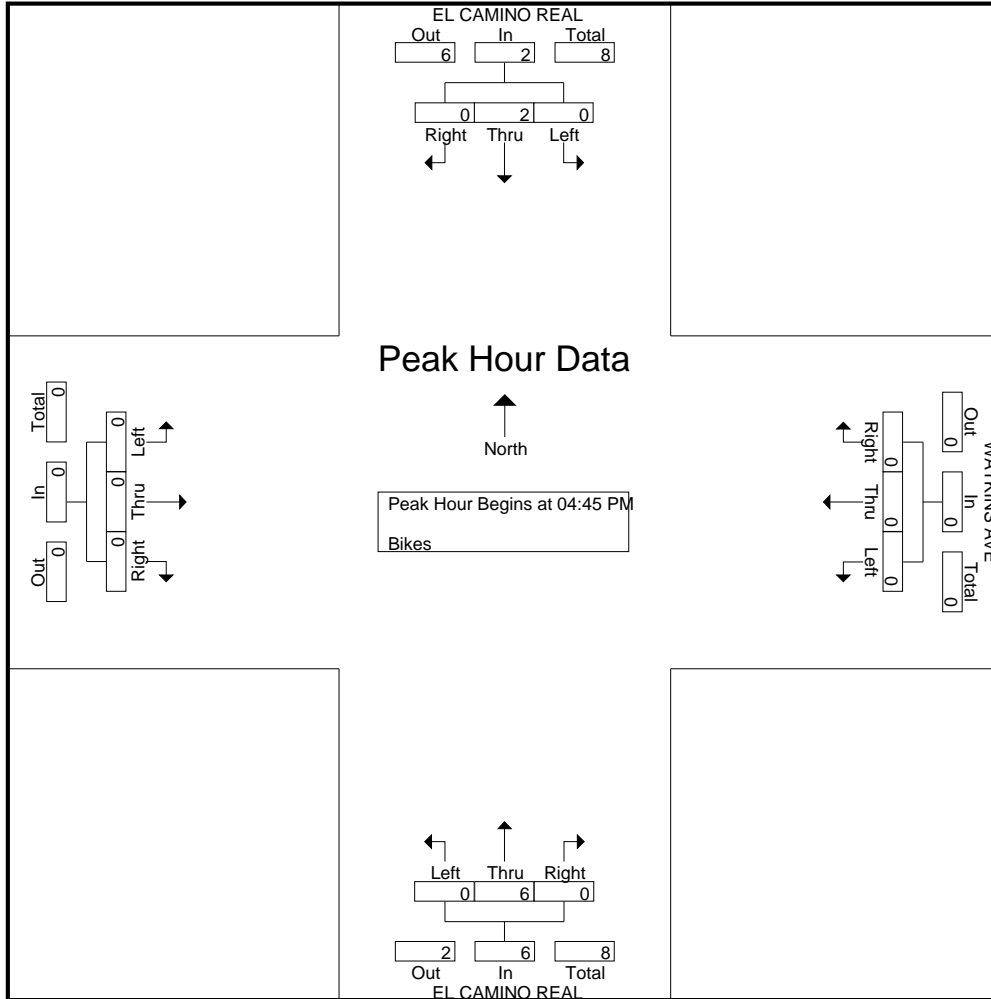

Traffic Data Service

Campbell, CA
 (408) 377-2988
 tdsbay@cs.com

File Name : 3AM FINAL
 Site Code : 00000003
 Start Date : 9/24/2013
 Page No : 1

Groups Printed- Vehicles

Start Time	PALMER LN Southbound					MIDDLEFIELD RD Westbound					FAIR OAKS LN Northbound					MIDDLEFIELD RD Eastbound					Int. Total
	Right	Thru	Left	Peds	App. Total	Right	Thru	Left	Peds	App. Total	Right	Thru	Left	Peds	App. Total	Right	Thru	Left	Peds	App. Total	
07:00 AM	2	2	2	2	8	1	57	32	0	90	12	0	0	0	12	11	84	1	0	96	206
07:15 AM	2	3	1	0	6	0	59	50	0	109	25	0	1	1	27	17	118	1	0	136	278
07:30 AM	9	16	1	1	27	0	79	54	1	134	43	0	0	0	43	20	159	0	0	179	383
07:45 AM	19	26	3	6	54	1	80	44	0	125	40	1	5	0	46	52	136	1	3	192	417
Total	32	47	7	9	95	2	275	180	1	458	120	1	6	1	128	100	497	3	3	603	1284
08:00 AM	13	15	1	2	31	0	106	53	1	160	39	2	5	0	46	18	112	1	0	131	368
08:15 AM	7	9	0	2	18	1	66	43	0	110	52	2	3	0	57	11	133	1	0	145	330
08:30 AM	5	8	2	4	19	1	102	39	0	142	39	3	3	0	45	13	151	1	0	165	371
08:45 AM	4	7	4	4	19	1	96	36	0	133	37	1	4	0	42	14	127	3	1	145	339
Total	29	39	7	12	87	3	370	171	1	545	167	8	15	0	190	56	523	6	1	586	1408
Grand Total	61	86	14	21	182	5	645	351	2	1003	287	9	21	1	318	156	1020	9	4	1189	2692
Apprch %	33.5	47.3	7.7	11.5		0.5	64.3	35	0.2		90.3	2.8	6.6	0.3		13.1	85.8	0.8	0.3		
Total %	2.3	3.2	0.5	0.8	6.8	0.2	24	13	0.1	37.3	10.7	0.3	0.8	0	11.8	5.8	37.9	0.3	0.1	44.2	

Start Time	PALMER LN Southbound				MIDDLEFIELD RD Westbound				FAIR OAKS LN Northbound				MIDDLEFIELD RD Eastbound				Int. Total
	Right	Thru	Left	App. Total	Right	Thru	Left	App. Total	Right	Thru	Left	App. Total	Right	Thru	Left	App. Total	
Peak Hour Analysis From 07:00 AM to 08:45 AM - Peak 1 of 1																	
Peak Hour for Entire Intersection Begins at 07:30 AM																	
07:30 AM	9	16	1	26	0	79	54	133	43	0	0	43	20	159	0	179	381
07:45 AM	19	26	3	48	1	80	44	125	40	1	5	46	52	136	1	189	408
08:00 AM	13	15	1	29	0	106	53	159	39	2	5	46	18	112	1	131	365
08:15 AM	7	9	0	16	1	66	43	110	52	2	3	57	11	133	1	145	328
Total Volume	48	66	5	119	2	331	194	527	174	5	13	192	101	540	3	644	1482
% App. Total	40.3	55.5	4.2		0.4	62.8	36.8		90.6	2.6	6.8		15.7	83.9	0.5		
PHF	.632	.635	.417	.620	.500	.781	.898	.829	.837	.625	.650	.842	.486	.849	.750	.852	.908

Traffic Data Service

Campbell, CA

(408) 377-2988

tdsbay@cs.com

File Name : 3AM FINAL

Site Code : 00000003

Start Date : 9/24/2013

Page No : 2

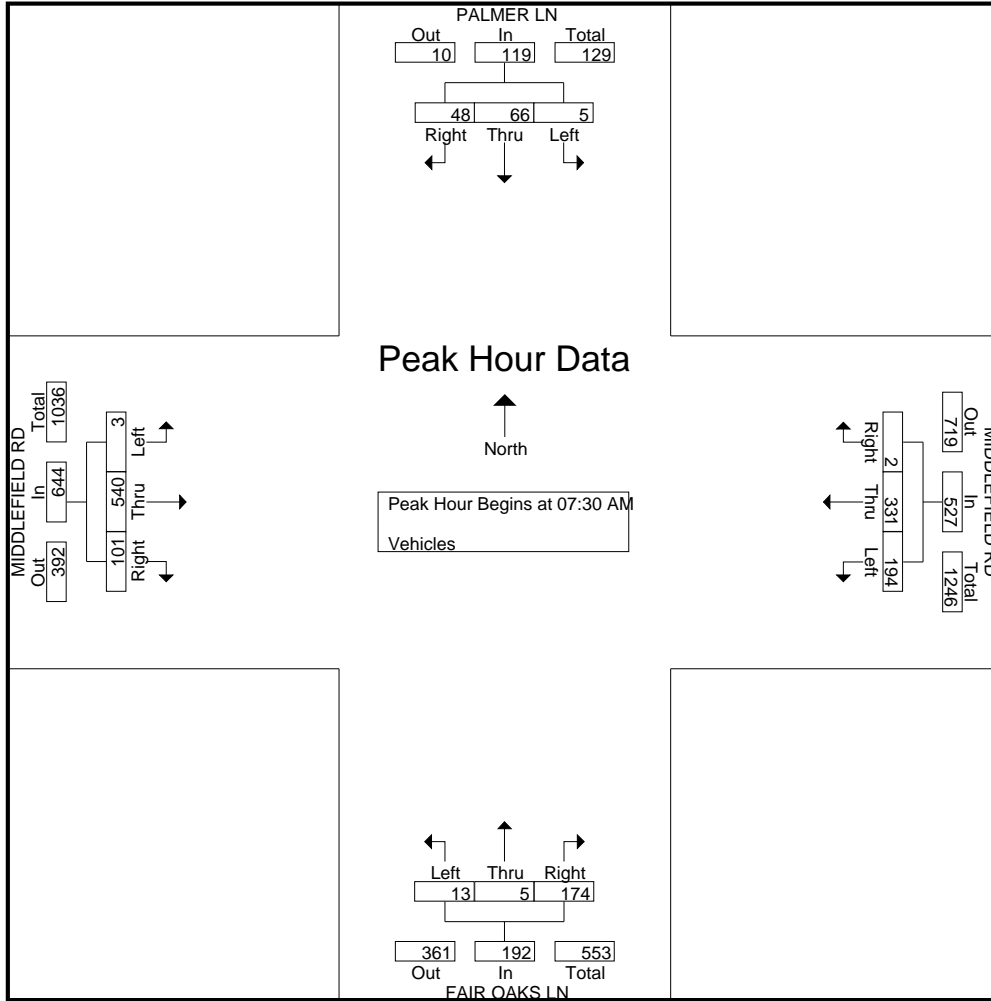

Traffic Data Service

Campbell, CA
 (408) 377-2988
 tdsbay@cs.com

File Name : 3AM FINAL
 Site Code : 00000003
 Start Date : 9/24/2013
 Page No : 1

Groups Printed- Bikes

Start Time	PALMER LN Southbound					MIDDLEFIELD RD Westbound					FAIR OAKS LN Northbound					MIDDLEFIELD RD Eastbound					Int. Total
	Right	Thru	Left	Peds	App. Total	Right	Thru	Left	Peds	App. Total	Right	Thru	Left	Peds	App. Total	Right	Thru	Left	Peds	App. Total	
07:00 AM	1	0	0	0	1	0	1	0	0	1	0	0	0	0	0	0	5	0	0	5	7
07:15 AM	0	0	2	0	2	0	2	0	0	2	0	0	0	0	0	0	5	0	0	5	9
07:30 AM	0	0	1	0	1	0	3	0	0	3	1	0	0	0	1	0	4	0	0	4	9
07:45 AM	0	0	1	1	2	0	2	0	0	2	0	2	0	0	2	2	5	0	0	7	13
Total	1	0	4	1	6	0	8	0	0	8	1	2	0	0	3	2	19	0	0	21	38
08:00 AM	2	0	0	0	2	0	1	0	0	1	0	0	1	0	1	0	2	0	0	2	6
08:15 AM	0	0	0	0	0	0	0	0	0	0	1	0	0	0	1	0	12	0	0	12	13
08:30 AM	0	0	0	0	0	0	1	0	0	1	1	0	0	0	1	0	8	0	0	8	10
08:45 AM	0	0	1	0	1	2	4	0	0	6	1	0	0	0	1	0	3	0	0	3	11
Total	2	0	1	0	3	2	6	0	0	8	3	0	1	0	4	0	25	0	0	25	40
Grand Total	3	0	5	1	9	2	14	0	0	16	4	2	1	0	7	2	44	0	0	46	78
Apprch %	33.3	0	55.6	11.1		12.5	87.5	0	0		57.1	28.6	14.3	0		4.3	95.7	0	0		
Total %	3.8	0	6.4	1.3	11.5	2.6	17.9	0	0	20.5	5.1	2.6	1.3	0	9	2.6	56.4	0	0	59	

Start Time	PALMER LN Southbound				MIDDLEFIELD RD Westbound				FAIR OAKS LN Northbound				MIDDLEFIELD RD Eastbound				Int. Total
	Right	Thru	Left	App. Total	Right	Thru	Left	App. Total	Right	Thru	Left	App. Total	Right	Thru	Left	App. Total	
07:45 AM	0	0	1	1	0	2	0	2	0	2	0	2	2	5	0	7	12
08:00 AM	2	0	0	2	0	1	0	1	0	0	1	1	0	2	0	2	6
08:15 AM	0	0	0	0	0	0	0	0	1	0	0	1	0	12	0	12	13
08:30 AM	0	0	0	0	0	1	0	1	1	0	0	1	0	8	0	8	10
Total Volume	2	0	1	3	0	4	0	4	2	2	1	5	2	27	0	29	41
% App. Total	66.7	0	33.3		0	100	0		40	40	20		6.9	93.1	0		
PHF	.250	.000	.250	.375	.000	.500	.000	.500	.500	.250	.250	.625	.250	.563	.000	.604	.788

Peak Hour Analysis From 07:00 AM to 08:45 AM - Peak 1 of 1

Peak Hour for Entire Intersection Begins at 07:45 AM

Traffic Data Service

Campbell, CA

(408) 377-2988

tdsbay@cs.com

File Name : 3AM FINAL

Site Code : 00000003

Start Date : 9/24/2013

Page No : 2

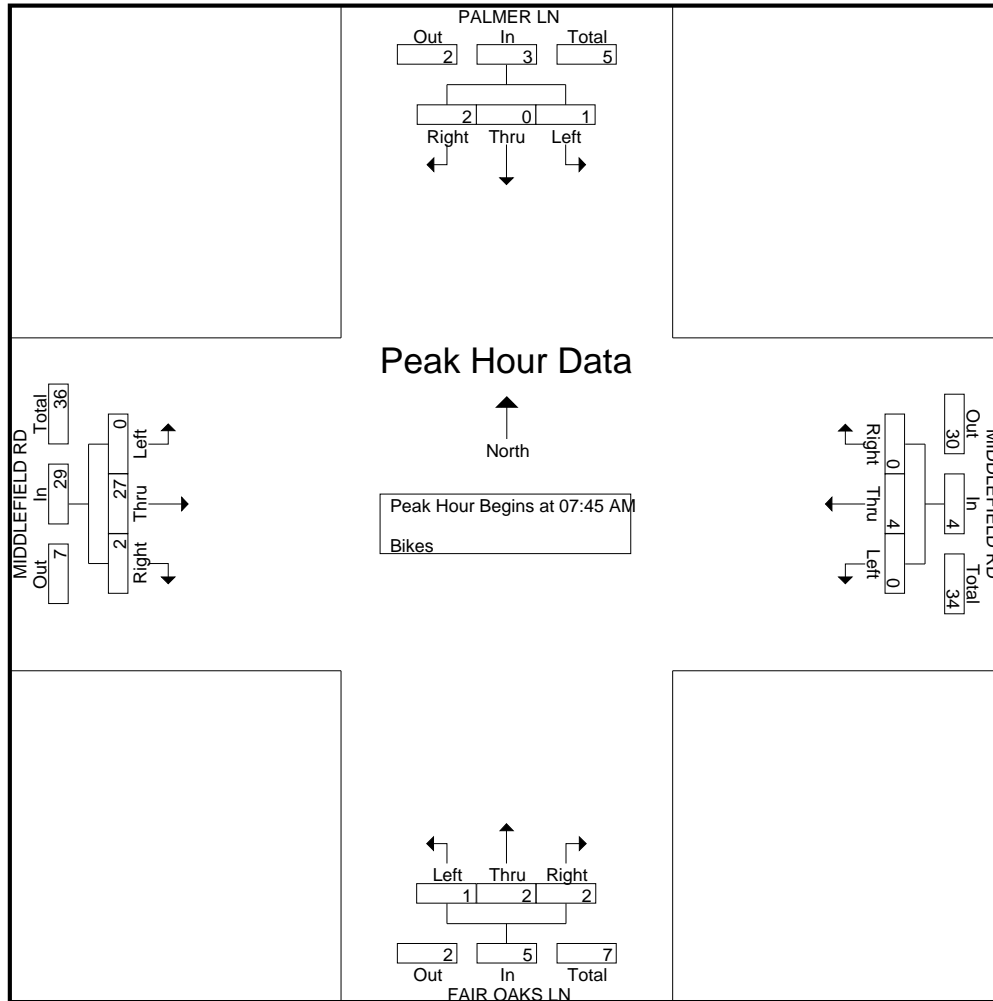

Traffic Data Service

Campbell, CA
 (408) 377-2988
 tdsbay@cs.com

File Name : 3PM FINAL
 Site Code : 00000003
 Start Date : 9/24/2013
 Page No : 1

Groups Printed- Vehicles

Start Time	PALMER LN Southbound					MIDDLEFIELD RD Westbound					FAIR OAKS LN Northbound					MIDDLEFIELD RD Eastbound					Int. Total
	Right	Thru	Left	Peds	App. Total	Right	Thru	Left	Peds	App. Total	Right	Thru	Left	Peds	App. Total	Right	Thru	Left	Peds	App. Total	
04:00 PM	5	0	1	1	7	3	161	32	0	196	52	6	10	0	68	7	93	5	0	105	376
04:15 PM	3	0	3	1	7	3	170	30	0	203	47	6	2	1	56	8	123	2	0	133	399
04:30 PM	1	0	0	1	2	1	151	32	0	184	43	3	9	1	56	6	130	4	0	140	382
04:45 PM	5	1	0	2	8	4	178	41	0	223	38	5	9	0	52	4	137	2	0	143	426
Total	14	1	4	5	24	11	660	135	0	806	180	20	30	2	232	25	483	13	0	521	1583
05:00 PM	2	3	0	1	6	4	163	51	0	218	30	2	10	0	42	12	154	3	0	169	435
05:15 PM	3	2	0	0	5	3	180	37	0	220	23	1	4	0	28	9	119	0	0	128	381
05:30 PM	4	1	0	0	5	3	182	51	0	236	31	5	5	0	41	9	128	5	0	142	424
05:45 PM	0	0	0	0	0	4	156	35	0	195	32	2	5	1	40	4	126	7	0	137	372
Total	9	6	0	1	16	14	681	174	0	869	116	10	24	1	151	34	527	15	0	576	1612
Grand Total	23	7	4	6	40	25	1341	309	0	1675	296	30	54	3	383	59	1010	28	0	1097	3195
Apprch %	57.5	17.5	10	15		1.5	80.1	18.4	0		77.3	7.8	14.1	0.8		5.4	92.1	2.6	0		
Total %	0.7	0.2	0.1	0.2	1.3	0.8	42	9.7	0	52.4	9.3	0.9	1.7	0.1	12	1.8	31.6	0.9	0	34.3	

Start Time	PALMER LN Southbound					MIDDLEFIELD RD Westbound					FAIR OAKS LN Northbound					MIDDLEFIELD RD Eastbound					Int. Total
	Right	Thru	Left	Peds	App. Total	Right	Thru	Left	Peds	App. Total	Right	Thru	Left	Peds	App. Total	Right	Thru	Left	Peds	App. Total	
04:45 PM	5	1	0	0	6	4	178	41	0	223	38	5	9	0	52	4	137	2	0	143	424
05:00 PM	2	3	0	0	5	4	163	51	0	218	30	2	10	0	42	12	154	3	0	169	434
05:15 PM	3	2	0	0	5	3	180	37	0	220	23	1	4	0	28	9	119	0	0	128	381
05:30 PM	4	1	0	0	5	3	182	51	0	236	31	5	5	0	41	9	128	5	0	142	424
Total Volume	14	7	0	0	21	14	703	180	0	897	122	13	28	0	163	34	538	10	0	582	1663
% App. Total	66.7	33.3	0	0		1.6	78.4	20.1	0		74.8	8	17.2	0		5.8	92.4	1.7	0		
PHF	.700	.583	.000	.000	.875	.875	.966	.882	.950		.803	.650	.700	.784		.708	.873	.500	.861		.958

Peak Hour Analysis From 04:00 PM to 05:45 PM - Peak 1 of 1

Peak Hour for Entire Intersection Begins at 04:45 PM

Traffic Data Service

Campbell, CA

(408) 377-2988

tdsbay@cs.com

File Name : 3PM FINAL

Site Code : 00000003

Start Date : 9/24/2013

Page No : 2

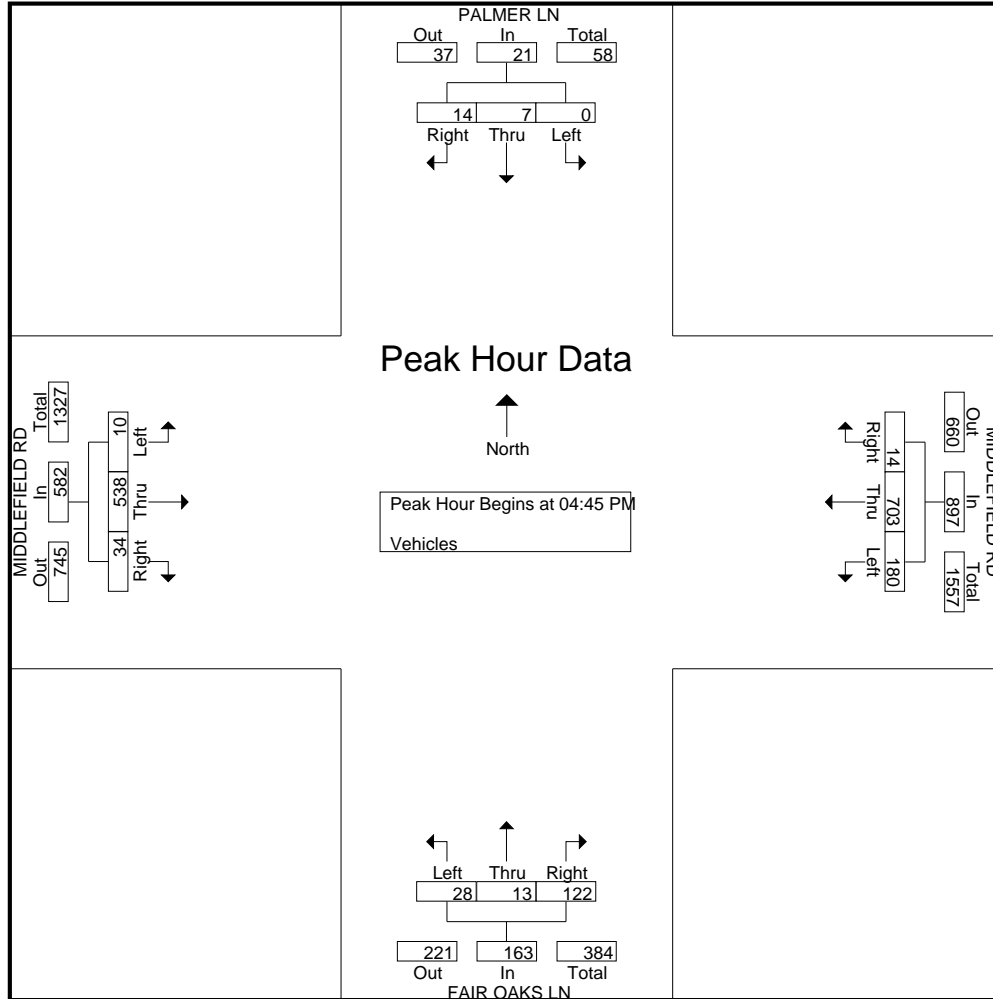

Traffic Data Service

Campbell, CA
 (408) 377-2988
 tdsbay@cs.com

File Name : 3PM FINAL
 Site Code : 00000003
 Start Date : 9/24/2013
 Page No : 1

Groups Printed- Bikes

Start Time	PALMER LN Southbound					MIDDLEFIELD RD Westbound					FAIR OAKS LN Northbound					MIDDLEFIELD RD Eastbound					Int. Total
	Right	Thru	Left	Peds	App. Total	Right	Thru	Left	Peds	App. Total	Right	Thru	Left	Peds	App. Total	Right	Thru	Left	Peds	App. Total	
04:00 PM	0	0	0	0	0	0	2	1	0	3	0	0	0	0	0	0	0	0	0	0	3
04:15 PM	0	0	0	0	0	0	1	0	0	1	0	0	0	0	0	0	2	0	0	0	2
04:30 PM	0	0	0	0	0	1	1	0	0	2	0	0	0	0	0	0	4	0	0	0	4
04:45 PM	0	0	0	0	0	2	0	0	0	2	0	0	0	0	0	2	0	0	0	0	2
Total	0	0	0	0	0	3	4	1	0	8	0	0	0	0	0	2	6	0	0	8	16
05:00 PM	0	0	0	0	0	0	0	0	0	0	0	0	0	0	0	0	1	0	0	1	1
05:15 PM	0	2	0	0	2	0	0	2	0	2	0	0	0	0	0	0	1	0	0	1	5
05:30 PM	0	1	0	0	1	0	0	0	0	0	0	0	1	0	1	1	2	0	0	3	5
05:45 PM	0	1	0	0	1	0	0	1	0	1	0	0	0	0	0	2	5	0	0	7	9
Total	0	4	0	0	4	0	0	3	0	3	0	0	1	0	1	3	9	0	0	12	20
Grand Total	0	4	0	0	4	3	4	4	0	11	0	0	1	0	1	5	15	0	0	20	36
Apprch %	0	100	0	0		27.3	36.4	36.4	0		0	0	100	0		25	75	0	0		
Total %	0	11.1	0	0	11.1	8.3	11.1	11.1	0	30.6	0	0	2.8	0	2.8	13.9	41.7	0	0	55.6	

Start Time	PALMER LN Southbound				MIDDLEFIELD RD Westbound				FAIR OAKS LN Northbound				MIDDLEFIELD RD Eastbound				Int. Total
	Right	Thru	Left	App. Total	Right	Thru	Left	App. Total	Right	Thru	Left	App. Total	Right	Thru	Left	App. Total	
05:00 PM	0	0	0	0	0	0	0	0	0	0	0	0	0	1	0	1	1
05:15 PM	0	2	0	2	0	0	2	2	0	0	0	0	0	1	0	1	5
05:30 PM	0	1	0	1	0	0	0	0	0	0	1	1	1	2	0	3	5
05:45 PM	0	1	0	1	0	0	1	1	0	0	0	0	2	5	0	7	9
Total Volume	0	4	0	4	0	0	3	3	0	0	1	1	3	9	0	12	20
% App. Total	0	100	0		0	0	100		0	0	100		25	75	0		
PHF	.000	.500	.000	.500	.000	.000	.375	.375	.000	.000	.250	.250	.375	.450	.000	.429	.556

Peak Hour Analysis From 04:00 PM to 05:45 PM - Peak 1 of 1

Peak Hour for Entire Intersection Begins at 05:00 PM

Traffic Data Service

Campbell, CA

(408) 377-2988

tdsbay@cs.com

File Name : 3PM FINAL

Site Code : 00000003

Start Date : 9/24/2013

Page No : 2

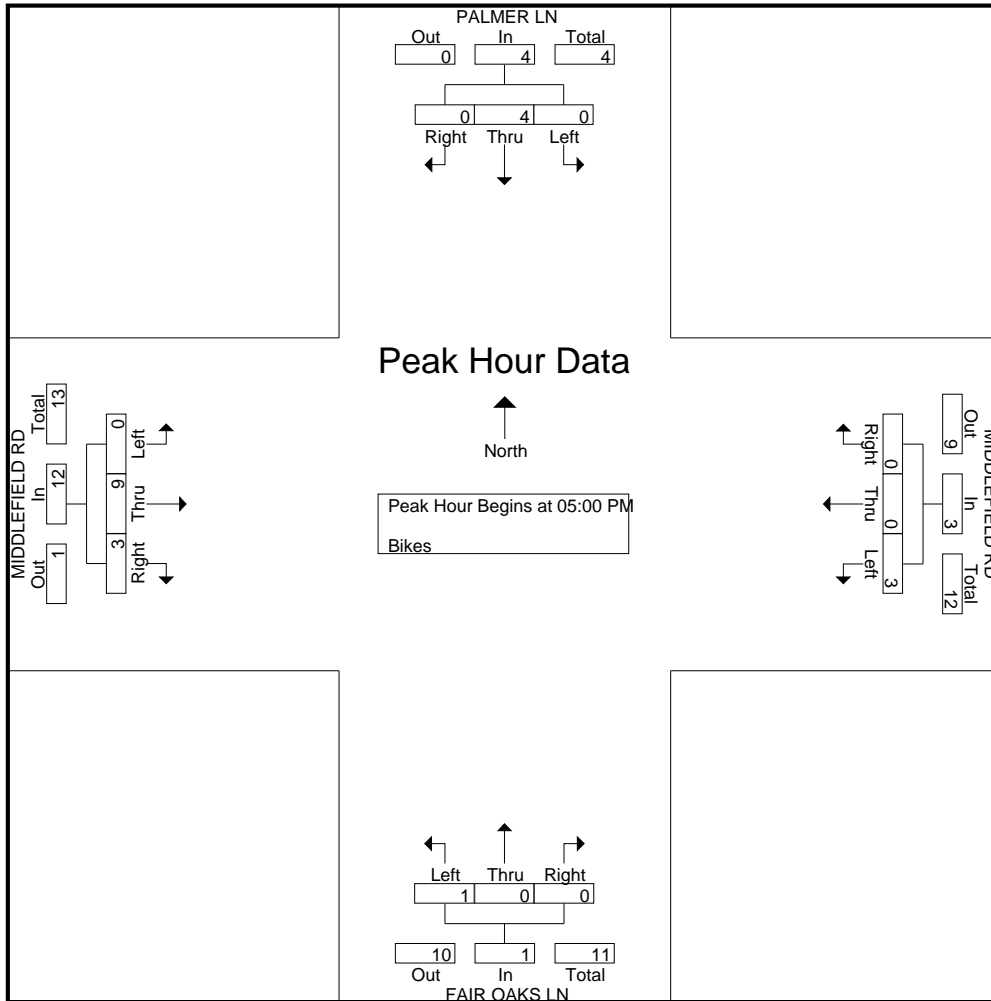

Traffic Data Service

Campbell, CA
 (408) 377-2988
 tdsbay@cs.com

File Name : 4AM FINAL
 Site Code : 00000004
 Start Date : 9/26/2013
 Page No : 1

Groups Printed- Vehicles

Start Time	Southbound					MIDDLEFIELD RD Westbound					WATKINS AVE Northbound					MIDDLEFIELD RD Eastbound					Int. Total
	Right	Thru	Left	Peds	App. Total	Right	Thru	Left	Peds	App. Total	Right	Thru	Left	Peds	App. Total	Right	Thru	Left	Peds	App. Total	
07:00 AM	0	0	0	0	0	0	59	0	1	60	8	0	8	1	17	18	130	0	0	148	225
07:15 AM	0	0	0	0	0	0	80	6	1	87	11	0	16	0	27	21	185	0	0	206	320
07:30 AM	0	0	0	0	0	0	123	19	1	143	20	0	7	0	27	23	248	0	0	271	441
07:45 AM	0	0	0	0	0	0	171	14	1	186	24	0	21	0	45	24	186	0	0	210	441
Total	0	0	0	0	0	0	433	39	4	476	63	0	52	1	116	86	749	0	0	835	1427
08:00 AM	0	0	0	0	0	0	169	9	0	178	12	0	11	1	24	19	185	0	0	204	406
08:15 AM	0	0	0	0	0	0	136	15	0	151	7	0	14	0	21	20	189	0	0	209	381
08:30 AM	0	0	0	0	0	0	150	10	0	160	18	0	20	0	38	28	185	0	0	213	411
08:45 AM	0	0	0	0	0	0	129	4	0	133	18	0	17	0	35	13	191	0	0	204	372
Total	0	0	0	0	0	0	584	38	0	622	55	0	62	1	118	80	750	0	0	830	1570
Grand Total	0	0	0	0	0	0	1017	77	4	1098	118	0	114	2	234	166	1499	0	0	1665	2997
Apprch %	0	0	0	0	0	0	92.6	7	0.4		50.4	0	48.7	0.9		10	90	0	0		
Total %	0	0	0	0	0	0	33.9	2.6	0.1	36.6	3.9	0	3.8	0.1	7.8	5.5	50	0	0	55.6	

Start Time	Southbound					MIDDLEFIELD RD Westbound					WATKINS AVE Northbound					MIDDLEFIELD RD Eastbound					Int. Total
	Right	Thru	Left	Peds	App. Total	Right	Thru	Left	Peds	App. Total	Right	Thru	Left	Peds	App. Total	Right	Thru	Left	Peds	App. Total	
Peak Hour Analysis From 07:00 AM to 08:45 AM - Peak 1 of 1																					
Peak Hour for Entire Intersection Begins at 07:30 AM																					
07:30 AM	0	0	0	0	0	0	123	19	1	142	20	0	7	0	27	23	248	0	0	271	440
07:45 AM	0	0	0	0	0	0	171	14	1	185	24	0	21	0	45	24	186	0	0	210	440
08:00 AM	0	0	0	0	0	0	169	9	0	178	12	0	11	1	23	19	185	0	0	204	405
08:15 AM	0	0	0	0	0	0	136	15	0	151	7	0	14	0	21	20	189	0	0	209	381
Total Volume	0	0	0	0	0	0	599	57	1	656	63	0	53	1	116	86	808	0	0	894	1666
% App. Total	0	0	0	0	0	0	91.3	8.7	0.1	100.0	54.3	0	45.7	0.9	100.0	9.6	90.4	0	0	100.0	100.0
PHF	.000	.000	.000	.000	.000	.000	.876	.750	.000	.886	.656	.000	.631	.000	.644	.896	.815	.000	.000	.825	.947

Traffic Data Service

Campbell, CA
(408) 377-2988
tdsbay@cs.com

File Name : 4AM FINAL
Site Code : 00000004
Start Date : 9/26/2013
Page No : 2

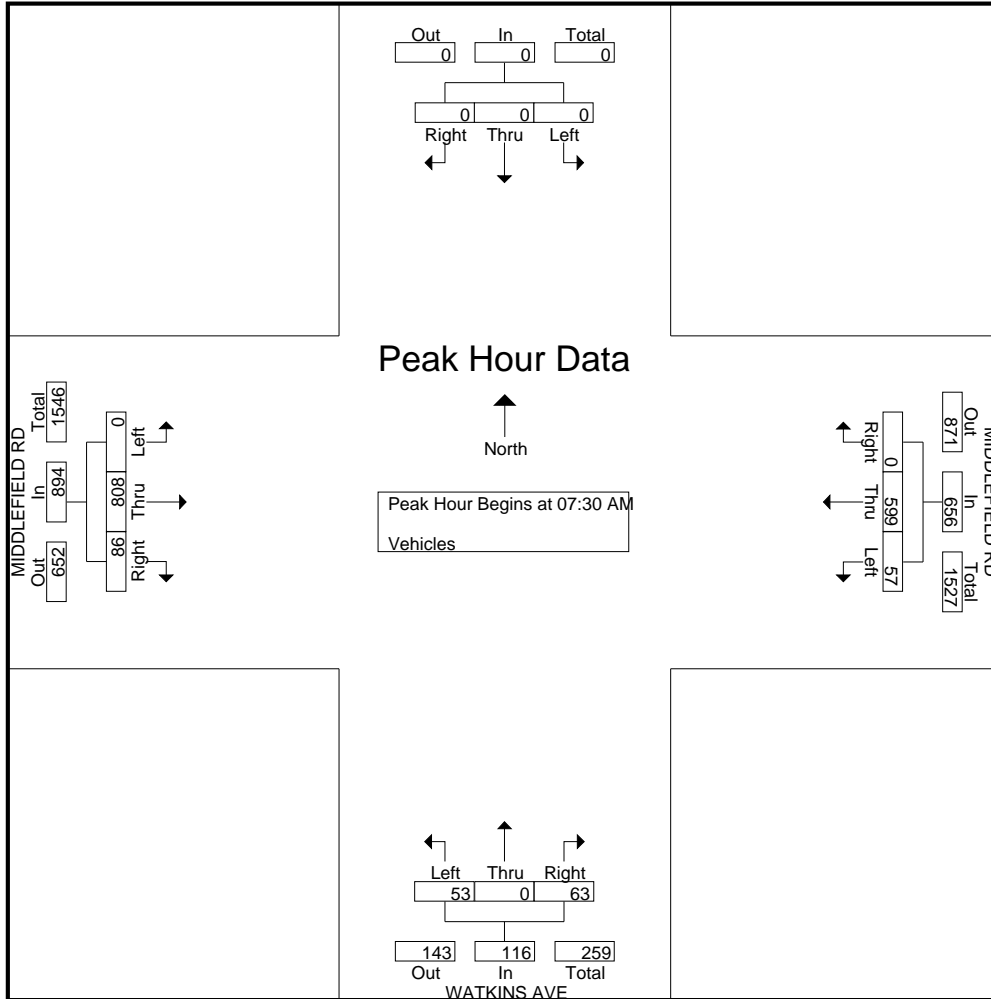

Traffic Data Service

Campbell, CA
(408) 377-2988
tdsbay@cs.com

File Name : 4AM FINAL
Site Code : 00000004
Start Date : 9/26/2013
Page No : 1

Groups Printed- Bikes

Start Time	Southbound					MIDDLEFIELD RD Westbound					WATKINS AVE Northbound					MIDDLEFIELD RD Eastbound					Int. Total
	Right	Thru	Left	Peds	App. Total	Right	Thru	Left	Peds	App. Total	Right	Thru	Left	Peds	App. Total	Right	Thru	Left	Peds	App. Total	
07:00 AM	0	0	0	0	0	0	1	0	0	1	0	0	0	0	0	0	2	0	0	2	3
07:15 AM	0	0	0	0	0	0	2	0	0	2	1	0	0	0	1	0	6	0	0	6	9
07:30 AM	0	0	0	0	0	0	5	0	0	5	0	0	0	0	0	0	13	0	0	13	18
07:45 AM	0	0	0	0	0	0	8	0	0	8	0	0	0	0	0	0	5	0	0	5	13
Total	0	0	0	0	0	0	16	0	0	16	1	0	0	0	1	0	26	0	0	26	43
08:00 AM	0	0	0	0	0	0	7	0	0	7	0	0	0	0	0	0	4	0	0	4	11
08:15 AM	0	0	0	0	0	0	1	0	0	1	0	0	0	0	0	1	12	0	0	13	14
08:30 AM	0	0	0	0	0	0	2	0	0	2	0	0	0	0	0	0	9	0	0	9	11
08:45 AM	0	0	0	0	0	0	3	0	0	3	0	0	0	0	0	0	15	0	0	15	18
Total	0	0	0	0	0	0	13	0	0	13	0	0	0	0	0	1	40	0	0	41	54
Grand Total	0	0	0	0	0	0	29	0	0	29	1	0	0	0	1	1	66	0	0	67	97
Apprch %	0	0	0	0	0	0	100	0	0	100	100	0	0	0	100	1.5	98.5	0	0	97.1	
Total %	0	0	0	0	0	0	29.9	0	0	29.9	1	0	0	0	1	1	68	0	0	69.1	

Start Time	Southbound				MIDDLEFIELD RD Westbound				WATKINS AVE Northbound				MIDDLEFIELD RD Eastbound				Int. Total
	Right	Thru	Left	App. Total	Right	Thru	Left	App. Total	Right	Thru	Left	App. Total	Right	Thru	Left	App. Total	
Peak Hour Analysis From 07:00 AM to 08:45 AM - Peak 1 of 1																	
Peak Hour for Entire Intersection Begins at 07:30 AM																	
07:30 AM	0	0	0	0	0	5	0	5	0	0	0	0	0	13	0	13	18
07:45 AM	0	0	0	0	0	8	0	8	0	0	0	0	0	5	0	5	13
08:00 AM	0	0	0	0	0	7	0	7	0	0	0	0	0	4	0	4	11
08:15 AM	0	0	0	0	0	1	0	1	0	0	0	0	1	12	0	13	14
Total Volume	0	0	0	0	0	21	0	21	0	0	0	0	1	34	0	35	56
% App. Total	0	0	0	0	0	100	0	100	0	0	0	0	2.9	97.1	0	97.1	
PHF	.000	.000	.000	.000	.000	.656	.000	.656	.000	.000	.000	.000	.250	.654	.000	.673	.778

Traffic Data Service

Campbell, CA

(408) 377-2988

tdsbay@cs.com

File Name : 4AM FINAL

Site Code : 00000004

Start Date : 9/26/2013

Page No : 2

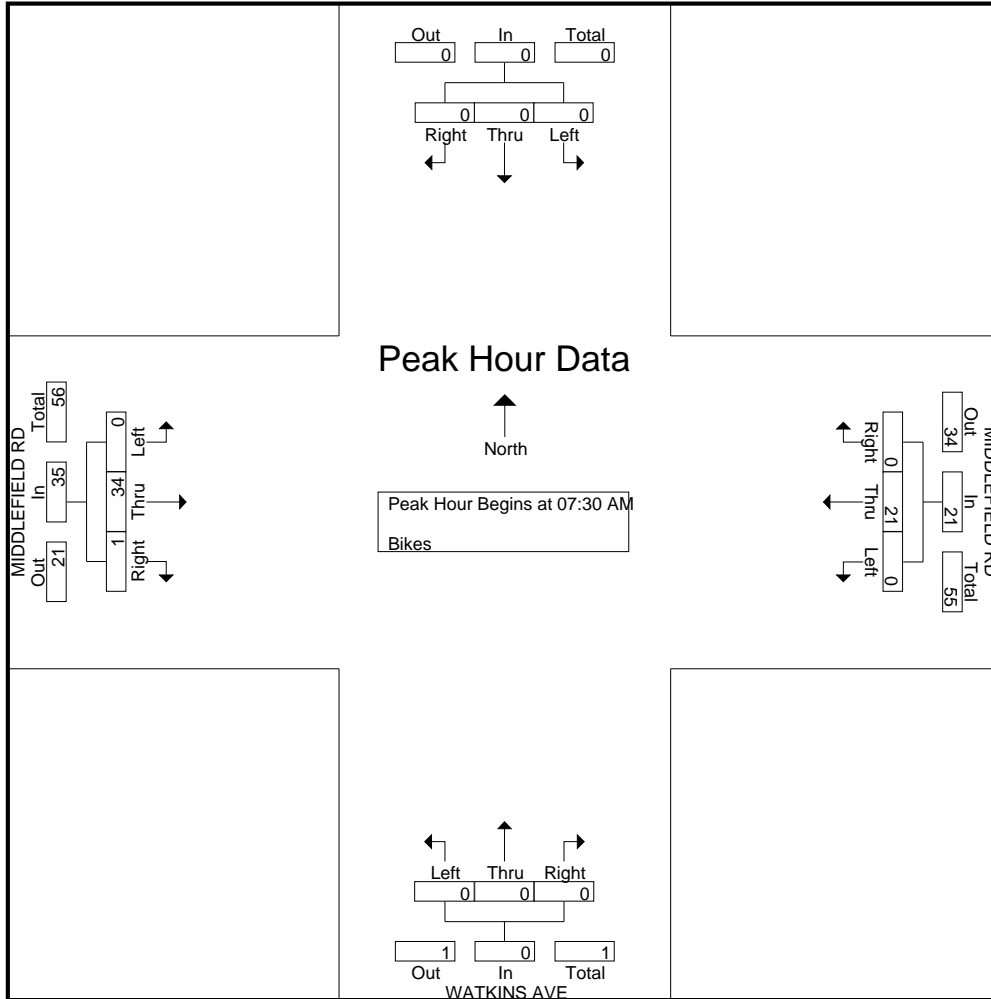

Traffic Data Service

Campbell, CA
 (408) 377-2988
 tdsbay@cs.com

File Name : 4PM FINAL
 Site Code : 00000004
 Start Date : 9/26/2013
 Page No : 1

Groups Printed- Vehicles

Start Time	Southbound					MIDDLEFIELD RD Westbound					WATKINS AVE Northbound					MIDDLEFIELD RD Eastbound					Int. Total
	Right	Thru	Left	Peds	App. Total	Right	Thru	Left	Peds	App. Total	Right	Thru	Left	Peds	App. Total	Right	Thru	Left	Peds	App. Total	
04:00 PM	0	0	0	0	0	0	226	21	1	248	11	0	13	0	24	12	158	0	0	170	442
04:15 PM	0	0	0	0	0	0	222	16	2	240	11	0	10	0	21	5	172	0	0	177	438
04:30 PM	0	0	0	0	0	0	237	15	13	265	13	0	15	0	28	7	172	0	0	179	472
04:45 PM	0	0	0	0	0	0	211	13	0	224	10	0	10	1	21	11	213	0	0	224	469
Total	0	0	0	0	0	0	896	65	16	977	45	0	48	1	94	35	715	0	0	750	1821
05:00 PM	0	0	0	0	0	0	226	18	2	246	6	0	12	1	19	10	163	0	0	173	438
05:15 PM	0	0	0	0	0	0	207	31	1	239	18	0	5	1	24	12	200	0	0	212	475
05:30 PM	0	0	0	0	0	0	207	13	5	225	19	0	14	0	33	17	161	0	0	178	436
05:45 PM	0	0	0	0	0	0	206	16	0	222	5	0	5	0	10	19	160	0	0	179	411
Total	0	0	0	0	0	0	846	78	8	932	48	0	36	2	86	58	684	0	0	742	1760
Grand Total	0	0	0	0	0	0	1742	143	24	1909	93	0	84	3	180	93	1399	0	0	1492	3581
Apprch %	0	0	0	0	0	0	91.3	7.5	1.3		51.7	0	46.7	1.7		6.2	93.8	0	0		
Total %	0	0	0	0	0	0	48.6	4	0.7	53.3	2.6	0	2.3	0.1	5	2.6	39.1	0	0	41.7	

Start Time	Southbound				MIDDLEFIELD RD Westbound				WATKINS AVE Northbound				MIDDLEFIELD RD Eastbound				Int. Total
	Right	Thru	Left	App. Total	Right	Thru	Left	App. Total	Right	Thru	Left	App. Total	Right	Thru	Left	App. Total	
Peak Hour Analysis From 04:00 PM to 05:45 PM - Peak 1 of 1																	
Peak Hour for Entire Intersection Begins at 04:30 PM																	
04:30 PM	0	0	0	0	0	237	15	252	13	0	15	28	7	172	0	179	459
04:45 PM	0	0	0	0	0	211	13	224	10	0	10	20	11	213	0	224	468
05:00 PM	0	0	0	0	0	226	18	244	6	0	12	18	10	163	0	173	435
05:15 PM	0	0	0	0	0	207	31	238	18	0	5	23	12	200	0	212	473
Total Volume	0	0	0	0	0	881	77	958	47	0	42	89	40	748	0	788	1835
% App. Total	0	0	0	0	0	92	8		52.8	0	47.2		5.1	94.9	0		
PHF	.000	.000	.000	.000	.000	.929	.621	.950	.653	.000	.700	.795	.833	.878	.000	.879	.970

Traffic Data Service

Campbell, CA
 (408) 377-2988
 tdsbay@cs.com

File Name : 4PM FINAL
 Site Code : 00000004
 Start Date : 9/26/2013
 Page No : 2

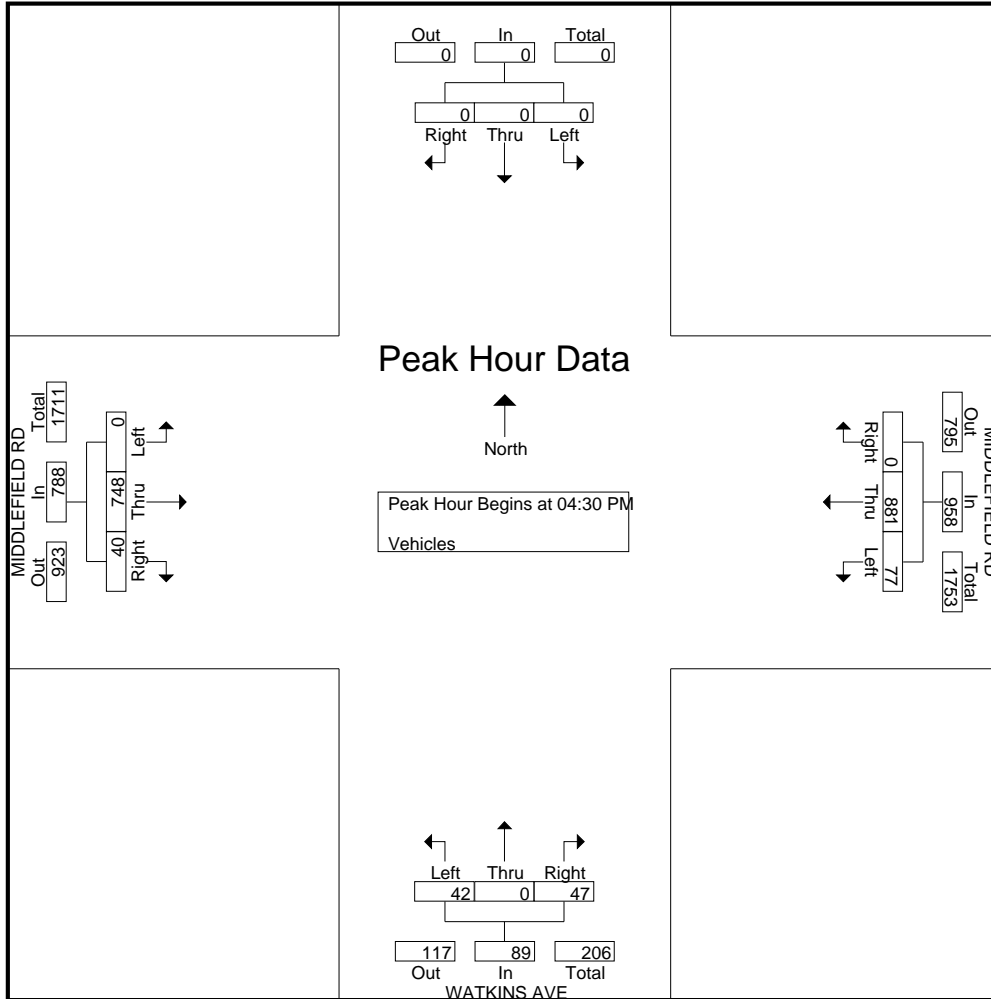

Traffic Data Service

Campbell, CA
 (408) 377-2988
 tdsbay@cs.com

File Name : 4PM FINAL
 Site Code : 00000004
 Start Date : 9/26/2013
 Page No : 1

Groups Printed- Bikes

Start Time	Southbound					MIDDLEFIELD RD Westbound					WATKINS AVE Northbound					MIDDLEFIELD RD Eastbound					Int. Total
	Right	Thru	Left	Peds	App. Total	Right	Thru	Left	Peds	App. Total	Right	Thru	Left	Peds	App. Total	Right	Thru	Left	Peds	App. Total	
04:00 PM	0	0	0	0	0	0	6	0	0	6	0	0	0	0	0	1	1	0	0	2	8
04:15 PM	0	0	0	0	0	0	2	1	0	3	0	0	0	0	0	0	2	0	0	2	5
04:30 PM	0	0	0	0	0	0	3	0	0	3	0	0	0	0	0	0	7	0	0	7	10
04:45 PM	0	0	0	0	0	0	4	0	0	4	0	0	0	0	0	0	1	0	0	1	5
Total	0	0	0	0	0	0	15	1	0	16	0	0	0	0	0	1	11	0	0	12	28
05:00 PM	0	0	0	0	0	0	5	1	0	6	0	0	0	0	0	0	2	0	0	2	8
05:15 PM	0	0	0	0	0	0	8	0	0	8	1	0	0	0	1	0	3	0	0	3	12
05:30 PM	0	0	0	0	0	0	8	0	0	8	0	0	0	0	0	0	4	0	0	4	12
05:45 PM	0	0	0	0	0	0	3	0	0	3	0	0	0	0	0	0	5	0	0	5	8
Total	0	0	0	0	0	0	24	1	0	25	1	0	0	0	1	0	14	0	0	14	40
Grand Total	0	0	0	0	0	0	39	2	0	41	1	0	0	0	1	1	25	0	0	26	68
Apprch %	0	0	0	0	0	0	95.1	4.9	0	60.3	100	0	0	0	1.5	3.8	96.2	0	0	38.2	
Total %	0	0	0	0	0	0	57.4	2.9	0	60.3	1.5	0	0	0	1.5	1.5	36.8	0	0	38.2	

Start Time	Southbound				MIDDLEFIELD RD Westbound				WATKINS AVE Northbound				MIDDLEFIELD RD Eastbound				Int. Total
	Right	Thru	Left	App. Total	Right	Thru	Left	App. Total	Right	Thru	Left	App. Total	Right	Thru	Left	App. Total	
Peak Hour Analysis From 04:00 PM to 05:45 PM - Peak 1 of 1																	
Peak Hour for Entire Intersection Begins at 05:00 PM																	
05:00 PM	0	0	0	0	0	5	1	6	0	0	0	0	0	2	0	2	8
05:15 PM	0	0	0	0	0	8	0	8	1	0	0	1	0	3	0	3	12
05:30 PM	0	0	0	0	0	8	0	8	0	0	0	0	0	4	0	4	12
05:45 PM	0	0	0	0	0	3	0	3	0	0	0	0	0	5	0	5	8
Total Volume	0	0	0	0	0	24	1	25	1	0	0	1	0	14	0	14	40
% App. Total	0	0	0	0	0	96	4	60.3	100	0	0	1.5	0	100	0	38.2	
PHF	.000	.000	.000	.000	.000	.750	.250	.781	.250	.000	.000	.250	.000	.700	.000	.700	.833

Traffic Data Service

Campbell, CA

(408) 377-2988

tdsbay@cs.com

File Name : 4PM FINAL

Site Code : 00000004

Start Date : 9/26/2013

Page No : 2

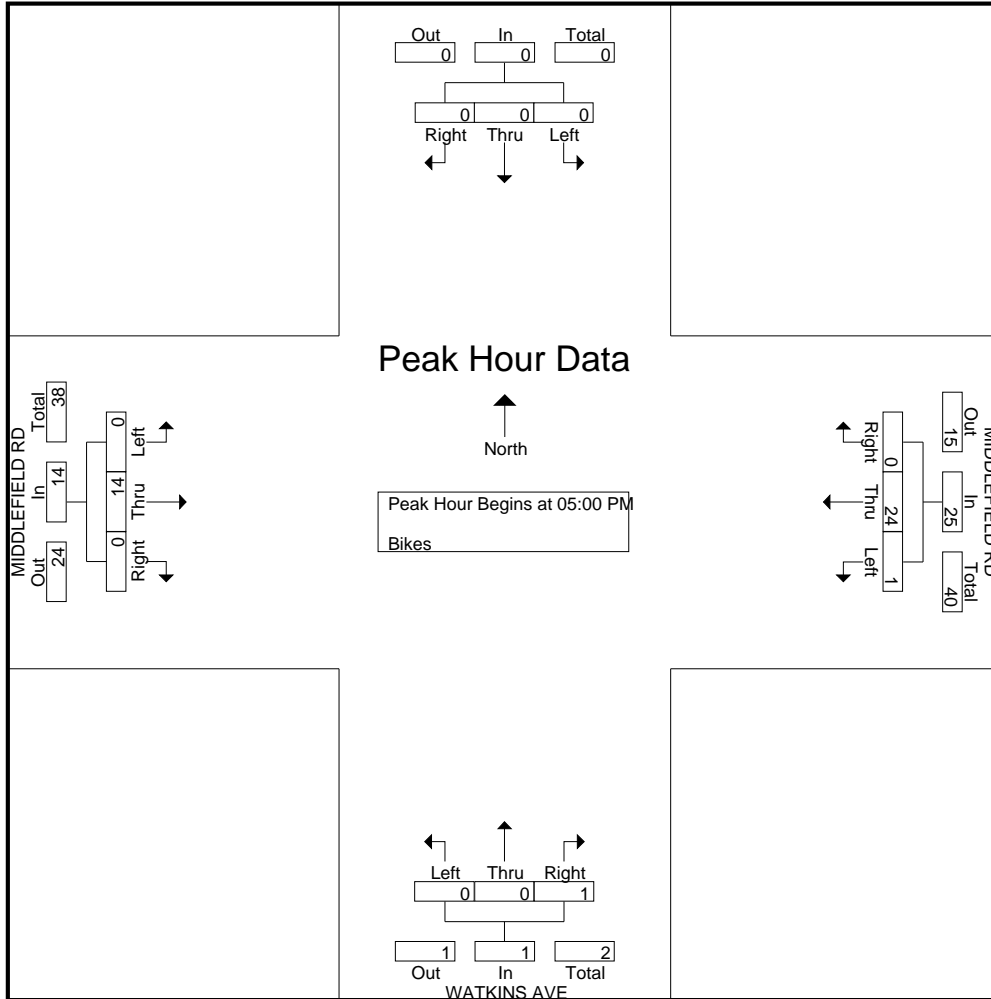

Traffic Data Service

Campbell, CA
(408) 377-2988
tdsbay@cs.com

File Name : 5AM FINAL
Site Code : 00000005
Start Date : 11/18/2009
Page No : 1

Groups Printed- Vehicles

Start Time	MIDDLEFIELD RD Southbound					GLENWOOD AVE Westbound					MIDDLEFIELD RD Northbound					GLENWOOD AVE Eastbound					Int. Total
	Right	Thru	Left	Peds	App. Total	Right	Thru	Left	Peds	App. Total	Right	Thru	Left	Peds	App. Total	Right	Thru	Left	Peds	App. Total	
07:00 AM	17	91	4	0	112	0	3	0	0	3	1	56	16	0	73	7	1	8	0	16	204
07:15 AM	23	110	5	0	138	3	5	0	0	8	7	83	17	0	107	6	2	11	0	19	272
07:30 AM	29	132	7	0	168	4	2	0	0	6	5	125	17	0	147	16	1	15	0	32	353
07:45 AM	28	137	5	0	170	3	2	8	0	13	2	147	15	0	164	26	2	11	0	39	386
Total	97	470	21	0	588	10	12	8	0	30	15	411	65	0	491	55	6	45	0	106	1215
08:00 AM	47	162	9	0	218	5	2	4	0	11	1	139	21	0	161	28	0	11	0	39	429
08:15 AM	32	153	2	0	187	5	2	3	0	10	2	124	32	0	158	14	1	17	0	32	387
08:30 AM	28	141	5	0	174	7	3	5	0	15	2	111	17	0	130	15	2	18	0	35	354
08:45 AM	28	151	7	0	186	1	4	2	0	7	1	92	23	0	116	11	3	16	0	30	339
Total	135	607	23	0	765	18	11	14	0	43	6	466	93	0	565	68	6	62	0	136	1509
Grand Total	232	1077	44	0	1353	28	23	22	0	73	21	877	158	0	1056	123	12	107	0	242	2724
Apprch %	17.1	79.6	3.3	0		38.4	31.5	30.1	0		2	83	15	0		50.8	5	44.2	0		
Total %	8.5	39.5	1.6	0	49.7	1	0.8	0.8	0	2.7	0.8	32.2	5.8	0	38.8	4.5	0.4	3.9	0	8.9	

Start Time	MIDDLEFIELD RD Southbound					GLENWOOD AVE Westbound					MIDDLEFIELD RD Northbound					GLENWOOD AVE Eastbound					Int. Total
	Right	Thru	Left	Peds	App. Total	Right	Thru	Left	Peds	App. Total	Right	Thru	Left	Peds	App. Total	Right	Thru	Left	Peds	App. Total	
Peak Hour Analysis From 07:00 AM to 08:45 AM - Peak 1 of 1																					
Peak Hour for Entire Intersection Begins at 07:45 AM																					
07:45 AM	28	137	5	0	170	3	2	8	0	13	2	147	15	0	164	26	2	11	0	39	386
08:00 AM	47	162	9	0	218	5	2	4	0	11	1	139	21	0	161	28	0	11	0	39	429
08:15 AM	32	153	2	0	187	5	2	3	0	10	2	124	32	0	158	14	1	17	0	32	387
08:30 AM	28	141	5	0	174	7	3	5	0	15	2	111	17	0	130	15	2	18	0	35	354
Total Volume	135	593	21	0	749	20	9	20	0	49	7	521	85	0	613	83	5	57	0	145	1556
% App. Total	18	79.2	2.8	0		40.8	18.4	40.8	0		1.1	85	13.9	0		57.2	3.4	39.3	0		
PHF	.718	.915	.583	.000	.859	.714	.750	.625	.000	.817	.875	.886	.664	.000	.934	.741	.625	.792	.000	.929	.907

Traffic Data Service

Campbell, CA
 (408) 377-2988
 tdsbay@cs.com

File Name : 5AM FINAL
 Site Code : 00000005
 Start Date : 11/18/2009
 Page No : 2

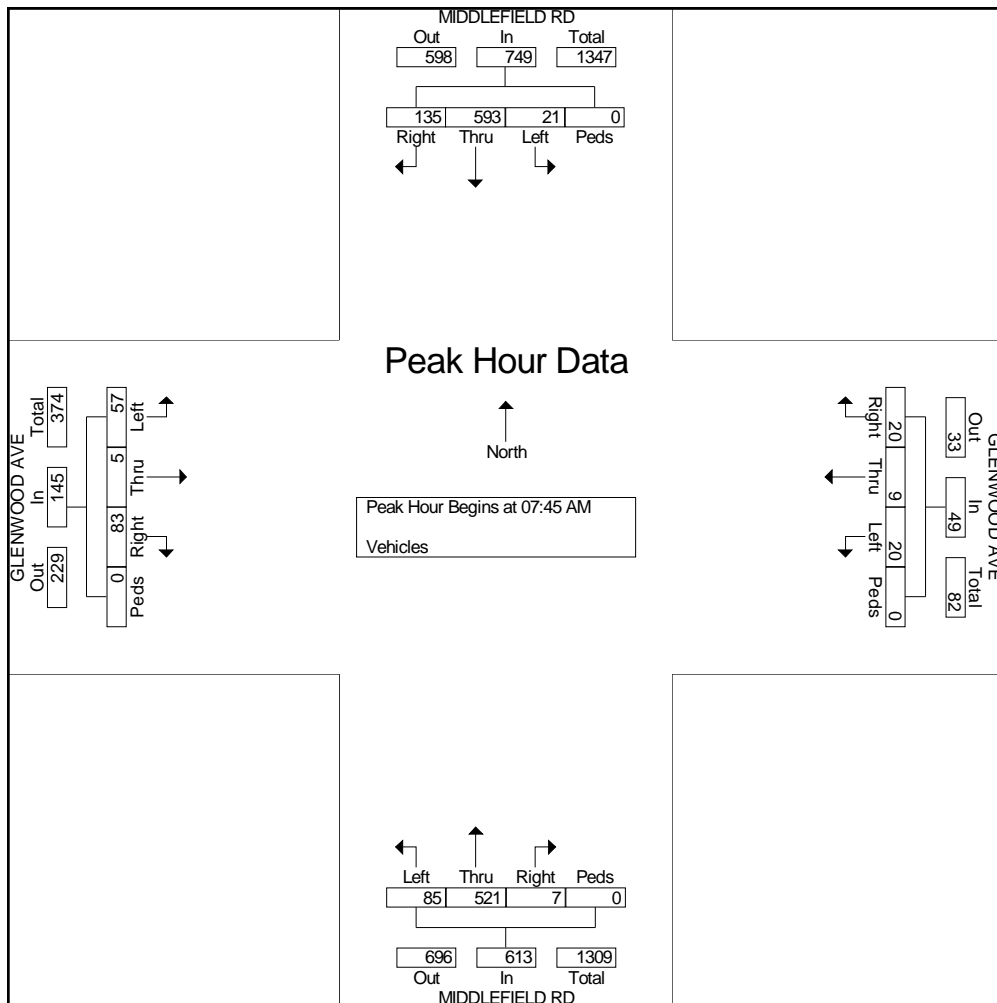

Traffic Data Service

Campbell, CA
(408) 377-2988
tdsbay@cs.com

File Name : 5PM FINAL
Site Code : 00000005
Start Date : 11/18/2009
Page No : 1

Groups Printed- Vehicles

Start Time	MIDDLEFIELD RD Southbound					GELNWOOD AVE Westbound					MIDDLEFIELD RD Northbound					GELNWOOD AVE Eastbound					Int. Total
	Right	Thru	Left	Peds	App. Total	Right	Thru	Left	Peds	App. Total	Right	Thru	Left	Peds	App. Total	Right	Thru	Left	Peds	App. Total	
04:00 PM	33	114	14	0	161	9	2	8	0	19	21	108	17	0	146	29	3	30	0	62	388
04:15 PM	30	119	8	0	157	5	3	10	0	18	9	96	33	0	138	26	6	29	0	61	374
04:30 PM	32	126	13	0	171	4	2	0	0	6	18	128	29	0	175	24	8	21	0	53	405
04:45 PM	37	131	15	0	183	6	0	4	0	10	30	131	35	0	196	22	10	17	0	49	438
Total	132	490	50	0	672	24	7	22	0	53	78	463	114	0	655	101	27	97	0	225	1605
05:00 PM	28	108	4	0	140	1	1	7	0	9	24	129	20	0	173	26	0	27	0	53	375
05:15 PM	29	106	14	0	149	7	0	6	0	13	17	132	29	0	178	33	1	23	0	57	397
05:30 PM	28	92	11	0	131	22	0	15	0	37	22	152	12	0	186	18	12	16	0	46	400
05:45 PM	27	98	12	0	137	16	0	10	0	26	24	126	21	0	171	29	6	27	0	62	396
Total	112	404	41	0	557	46	1	38	0	85	87	539	82	0	708	106	19	93	0	218	1568
Grand Total	244	894	91	0	1229	70	8	60	0	138	165	1002	196	0	1363	207	46	190	0	443	3173
Apprch %	19.9	72.7	7.4	0		50.7	5.8	43.5	0		12.1	73.5	14.4	0		46.7	10.4	42.9	0		
Total %	7.7	28.2	2.9	0	38.7	2.2	0.3	1.9	0	4.3	5.2	31.6	6.2	0	43	6.5	1.4	6	0	14	

Start Time	MIDDLEFIELD RD Southbound					GELNWOOD AVE Westbound					MIDDLEFIELD RD Northbound					GELNWOOD AVE Eastbound					Int. Total
	Right	Thru	Left	Peds	App. Total	Right	Thru	Left	Peds	App. Total	Right	Thru	Left	Peds	App. Total	Right	Thru	Left	Peds	App. Total	
Peak Hour Analysis From 04:00 PM to 05:45 PM - Peak 1 of 1																					
Peak Hour for Entire Intersection Begins at 04:30 PM																					
04:30 PM	32	126	13	0	171	4	2	0	0	6	18	128	29	0	175	24	8	21	0	53	405
04:45 PM	37	131	15	0	183	6	0	4	0	10	30	131	35	0	196	22	10	17	0	49	438
05:00 PM	28	108	4	0	140	1	1	7	0	9	24	129	20	0	173	26	0	27	0	53	375
05:15 PM	29	106	14	0	149	7	0	6	0	13	17	132	29	0	178	33	1	23	0	57	397
Total Volume	126	471	46	0	643	18	3	17	0	38	89	520	113	0	722	105	19	88	0	212	1615
% App. Total	19.6	73.3	7.2	0		47.4	7.9	44.7	0		12.3	72	15.7	0		49.5	9	41.5	0		
PHF	.851	.899	.767	.000	.878	.643	.375	.607	.000	.731	.742	.985	.807	.000	.921	.795	.475	.815	.000	.930	.922

Traffic Data Service

Campbell, CA
 (408) 377-2988
 tdsbay@cs.com

File Name : 5PM FINAL
 Site Code : 00000005
 Start Date : 11/18/2009
 Page No : 2

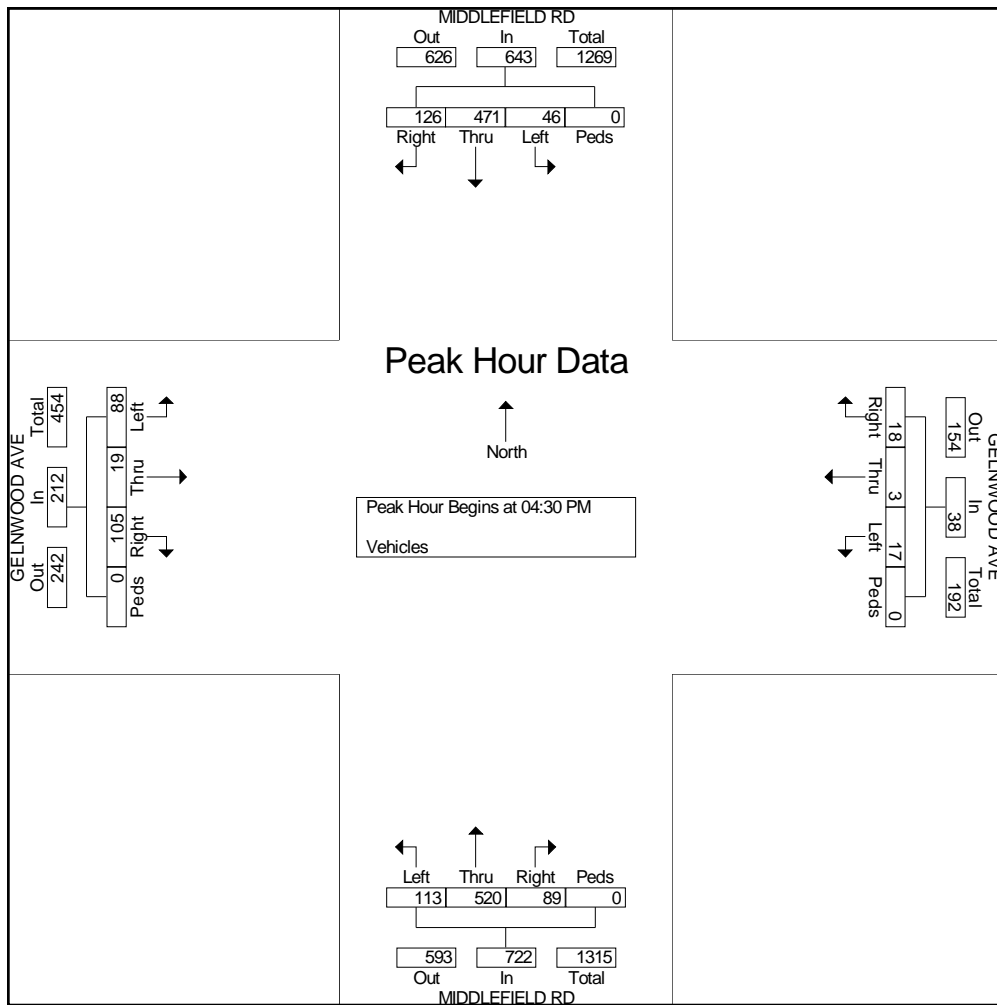

Traffic Data Service

Campbell, CA
 (408) 377-2988
 tdsbay@cs.com

File Name : 77AM FINAL
 Site Code : 00000077
 Start Date : 6/4/2013
 Page No : 1

Groups Printed- Vehicles

Start Time	EL CAMINO REAL Southbound					GLENWOOD AVE Westbound					EL CAMINO REAL Northbound					VALPARAISO AVE Eastbound					Int. Total
	Right	Thru	Left	Peds	App. Total	Right	Thru	Left	Peds	App. Total	Right	Thru	Left	Peds	App. Total	Right	Thru	Left	Peds	App. Total	
07:00 AM	39	178	3	0	220	0	18	7	0	25	1	66	9	1	77	9	16	18	1	44	366
07:15 AM	72	262	5	5	344	0	35	11	0	46	8	97	19	1	125	12	19	29	0	60	575
07:30 AM	100	322	15	1	438	2	38	6	0	46	5	125	33	1	164	19	15	44	4	82	730
07:45 AM	128	339	24	1	492	3	53	19	0	75	11	152	22	0	185	21	41	56	1	119	871
Total	339	1101	47	7	1494	5	144	43	0	192	25	440	83	3	551	61	91	147	6	305	2542
08:00 AM	145	294	17	0	456	3	71	18	2	94	9	149	24	1	183	18	34	63	0	115	848
08:15 AM	103	361	12	0	476	0	35	15	6	56	8	167	14	2	191	20	46	82	0	148	871
08:30 AM	94	348	16	0	458	3	32	10	2	47	6	164	11	1	182	26	34	58	0	118	805
08:45 AM	120	352	18	0	490	5	49	23	4	81	11	160	18	2	191	21	33	55	0	109	871
Total	462	1355	63	0	1880	11	187	66	14	278	34	640	67	6	747	85	147	258	0	490	3395
Grand Total	801	2456	110	7	3374	16	331	109	14	470	59	1080	150	9	1298	146	238	405	6	795	5937
Apprch %	23.7	72.8	3.3	0.2		3.4	70.4	23.2	3		4.5	83.2	11.6	0.7		18.4	29.9	50.9	0.8		
Total %	13.5	41.4	1.9	0.1	56.8	0.3	5.6	1.8	0.2	7.9	1	18.2	2.5	0.2	21.9	2.5	4	6.8	0.1	13.4	

Start Time	EL CAMINO REAL Southbound				GLENWOOD AVE Westbound				EL CAMINO REAL Northbound				VALPARAISO AVE Eastbound				Int. Total
	Right	Thru	Left	App. Total	Right	Thru	Left	App. Total	Right	Thru	Left	App. Total	Right	Thru	Left	App. Total	
Peak Hour Analysis From 07:00 AM to 08:45 AM - Peak 1 of 1																	
Peak Hour for Entire Intersection Begins at 07:45 AM																	
07:45 AM	128	339	24	491	3	53	19	75	11	152	22	185	21	41	56	118	869
08:00 AM	145	294	17	456	3	71	18	92	9	149	24	182	18	34	63	115	845
08:15 AM	103	361	12	476	0	35	15	50	8	167	14	189	20	46	82	148	863
08:30 AM	94	348	16	458	3	32	10	45	6	164	11	181	26	34	58	118	802
Total Volume	470	1342	69	1881	9	191	62	262	34	632	71	737	85	155	259	499	3379
% App. Total	25	71.3	3.7		3.4	72.9	23.7		4.6	85.8	9.6		17	31.1	51.9		
PHF	.810	.929	.719	.958	.750	.673	.816	.712	.773	.946	.740	.975	.817	.842	.790	.843	.972

Traffic Data Service

Campbell, CA
 (408) 377-2988
 tdsbay@cs.com

File Name : 77AM FINAL
 Site Code : 00000077
 Start Date : 6/4/2013
 Page No : 2

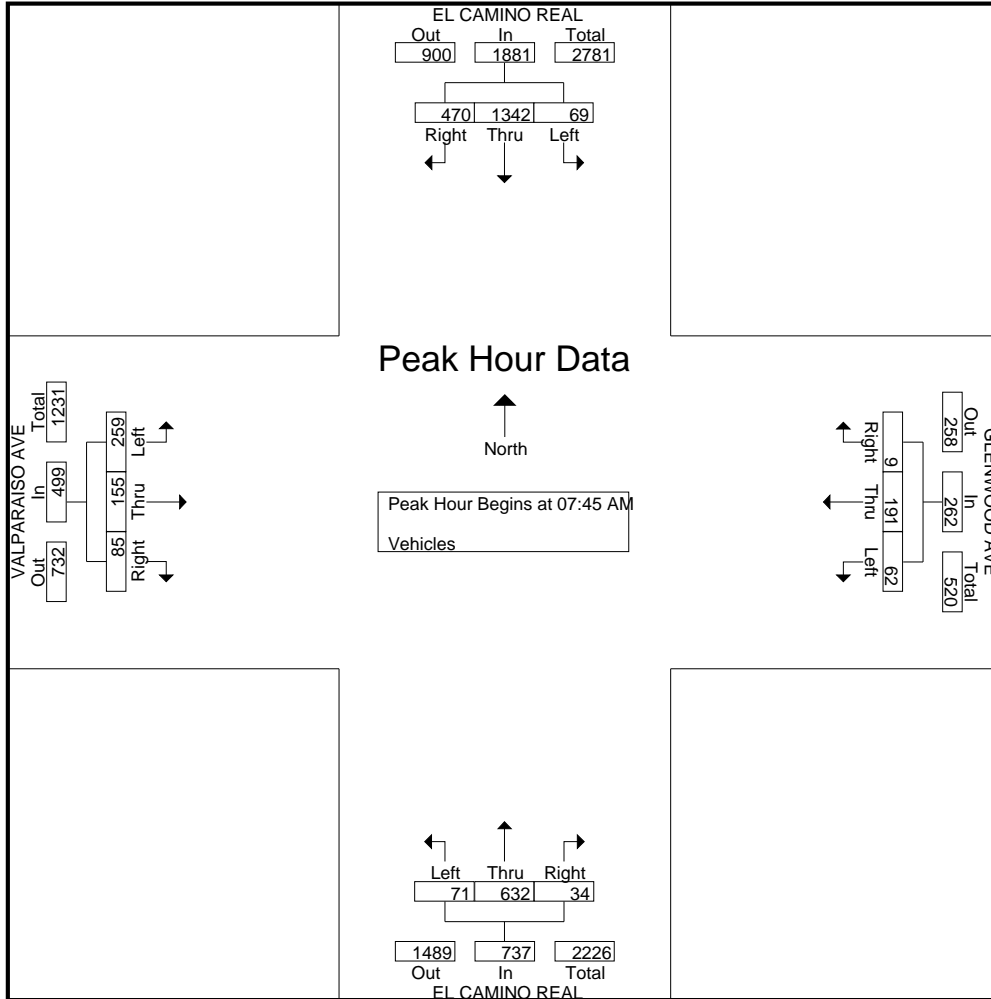

Traffic Data Service

Campbell, CA
 (408) 377-2988
 tdsbay@cs.com

File Name : 77AM FINAL
 Site Code : 00000077
 Start Date : 6/4/2013
 Page No : 1

Groups Printed- Bikes

Start Time	EL CAMINO REAL Southbound					GLENWOOD AVE Westbound					EL CAMINO REAL Northbound					VALPARAISO AVE Eastbound					Int. Total
	Right	Thru	Left	Peds	App. Total	Right	Thru	Left	Peds	App. Total	Right	Thru	Left	Peds	App. Total	Right	Thru	Left	Peds	App. Total	
07:00 AM	1	1	0	0	2	0	0	0	0	0	1	0	0	0	1	0	2	0	0	2	5
07:15 AM	0	1	0	0	1	0	0	0	0	0	0	1	0	0	1	0	0	0	0	0	2
07:30 AM	0	3	0	0	3	0	1	0	0	1	0	0	0	0	0	0	1	0	0	1	5
07:45 AM	0	1	0	0	1	0	3	0	0	3	0	1	0	0	1	0	5	0	0	5	10
Total	1	6	0	0	7	0	4	0	0	4	1	2	0	0	3	0	8	0	0	8	22
08:00 AM	0	1	0	0	1	0	1	0	0	1	1	1	0	0	2	0	2	0	0	2	6
08:15 AM	0	3	0	0	3	0	2	0	0	2	0	3	0	0	3	0	4	0	0	4	12
08:30 AM	0	2	0	0	2	0	1	0	0	1	0	1	0	0	1	0	2	0	0	2	6
08:45 AM	0	0	0	0	0	0	2	1	0	3	1	0	0	0	1	0	3	0	0	3	7
Total	0	6	0	0	6	0	6	1	0	7	2	5	0	0	7	0	11	0	0	11	31
Grand Total	1	12	0	0	13	0	10	1	0	11	3	7	0	0	10	0	19	0	0	19	53
Apprch %	7.7	92.3	0	0		0	90.9	9.1	0		30	70	0	0		0	100	0	0		
Total %	1.9	22.6	0	0	24.5	0	18.9	1.9	0	20.8	5.7	13.2	0	0	18.9	0	35.8	0	0	35.8	

Start Time	EL CAMINO REAL Southbound				GLENWOOD AVE Westbound				EL CAMINO REAL Northbound				VALPARAISO AVE Eastbound				Int. Total
	Right	Thru	Left	App. Total	Right	Thru	Left	App. Total	Right	Thru	Left	App. Total	Right	Thru	Left	App. Total	
07:45 AM	0	1	0	1	0	3	0	3	0	1	0	1	0	5	0	5	10
08:00 AM	0	1	0	1	0	1	0	1	1	1	0	2	0	2	0	2	6
08:15 AM	0	3	0	3	0	2	0	2	0	3	0	3	0	4	0	4	12
08:30 AM	0	2	0	2	0	1	0	1	0	1	0	1	0	2	0	2	6
Total Volume	0	7	0	7	0	7	0	7	1	6	0	7	0	13	0	13	34
% App. Total	0	100	0		0	100	0		14.3	85.7	0		0	100	0		
PHF	.000	.583	.000	.583	.000	.583	.000	.583	.250	.500	.000	.583	.000	.650	.000	.650	.708

Peak Hour Analysis From 07:00 AM to 08:45 AM - Peak 1 of 1

Peak Hour for Entire Intersection Begins at 07:45 AM

Traffic Data Service

Campbell, CA
(408) 377-2988
tdsbay@cs.com

File Name : 77AM FINAL
Site Code : 00000077
Start Date : 6/4/2013
Page No : 2

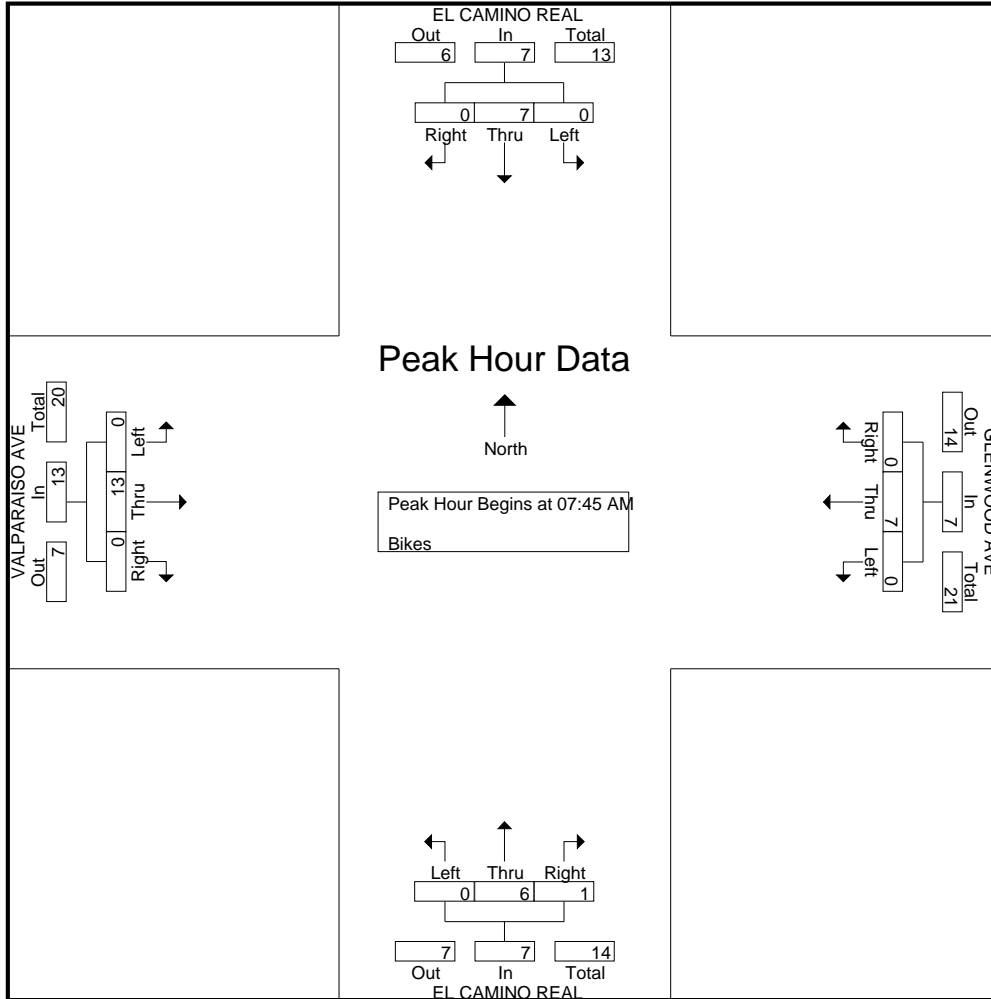

Traffic Data Service

Campbell, CA
 (408) 377-2988
 tdsbay@cs.com

File Name : 77PM FINAL
 Site Code : 00000077
 Start Date : 6/4/2013
 Page No : 1

Groups Printed- Vehicles

Start Time	EL CAMINO REAL Southbound					GLENWOOD AVE Westbound					EL CAMINO REAL Northbound					VALPARAISO AVE Eastbound					Int. Total
	Right	Thru	Left	Peds	App. Total	Right	Thru	Left	Peds	App. Total	Right	Thru	Left	Peds	App. Total	Right	Thru	Left	Peds	App. Total	
04:00 PM	56	199	3	3	261	7	33	11	3	54	9	324	32	1	366	23	31	84	0	138	819
04:15 PM	63	223	16	0	302	4	35	15	1	55	12	316	34	3	365	24	33	101	2	160	882
04:30 PM	75	204	8	1	288	6	32	15	3	56	16	327	27	0	370	21	30	87	0	138	852
04:45 PM	59	235	5	1	300	7	38	18	3	66	5	380	23	1	409	23	29	76	0	128	903
Total	253	861	32	5	1151	24	138	59	10	231	42	1347	116	5	1510	91	123	348	2	564	3456
05:00 PM	51	211	6	0	268	11	49	11	0	71	17	391	25	4	437	33	23	89	1	146	922
05:15 PM	66	224	15	0	305	3	39	17	0	59	8	399	22	4	433	12	27	70	1	110	907
05:30 PM	66	231	12	0	309	4	35	10	0	49	7	376	37	1	421	18	33	80	0	131	910
05:45 PM	61	240	17	0	318	6	28	14	0	48	6	349	31	5	391	21	19	75	0	115	872
Total	244	906	50	0	1200	24	151	52	0	227	38	1515	115	14	1682	84	102	314	2	502	3611
Grand Total	497	1767	82	5	2351	48	289	111	10	458	80	2862	231	19	3192	175	225	662	4	1066	7067
Apprch %	21.1	75.2	3.5	0.2		10.5	63.1	24.2	2.2		2.5	89.7	7.2	0.6		16.4	21.1	62.1	0.4		
Total %	7	25	1.2	0.1	33.3	0.7	4.1	1.6	0.1	6.5	1.1	40.5	3.3	0.3	45.2	2.5	3.2	9.4	0.1	15.1	

Start Time	EL CAMINO REAL Southbound					GLENWOOD AVE Westbound					EL CAMINO REAL Northbound					VALPARAISO AVE Eastbound					Int. Total
	Right	Thru	Left	Peds	App. Total	Right	Thru	Left	Peds	App. Total	Right	Thru	Left	Peds	App. Total	Right	Thru	Left	Peds	App. Total	
04:45 PM	59	235	5		299	7	38	18		63	5	380	23		408	23	29	76		128	898
05:00 PM	51	211	6		268	11	49	11		71	17	391	25		433	33	23	89		145	917
05:15 PM	66	224	15		305	3	39	17		59	8	399	22		429	12	27	70		109	902
05:30 PM	66	231	12		309	4	35	10		49	7	376	37		420	18	33	80		131	909
Total Volume	242	901	38		1181	25	161	56		242	37	1546	107		1690	86	112	315		513	3626
% App. Total	20.5	76.3	3.2			10.3	66.5	23.1			2.2	91.5	6.3			16.8	21.8	61.4			
PHF	.917	.959	.633		.956	.568	.821	.778		.852	.544	.969	.723		.976	.652	.848	.885		.884	.989

Peak Hour Analysis From 04:00 PM to 05:45 PM - Peak 1 of 1

Peak Hour for Entire Intersection Begins at 04:45 PM

Traffic Data Service

Campbell, CA
 (408) 377-2988
 tdsbay@cs.com

File Name : 77PM FINAL
 Site Code : 00000077
 Start Date : 6/4/2013
 Page No : 2

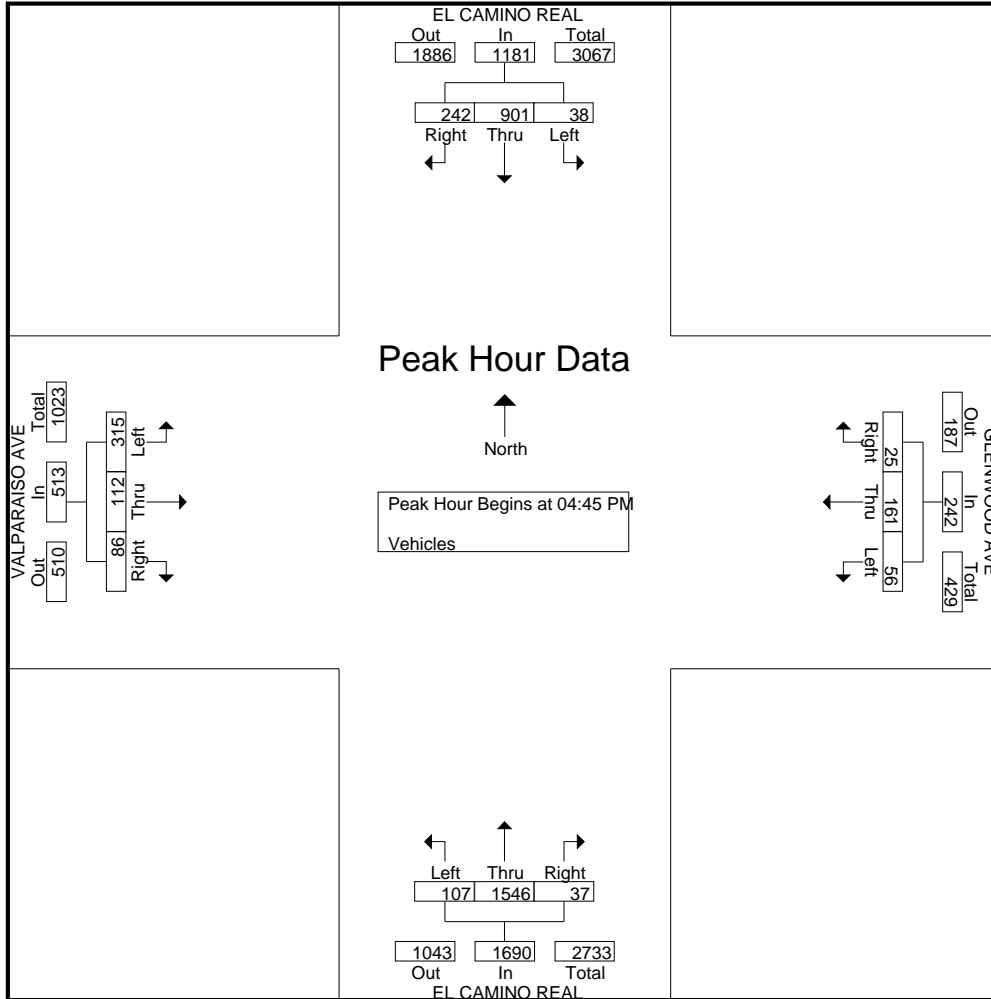

Traffic Data Service

Campbell, CA
 (408) 377-2988
 tdsbay@cs.com

File Name : 77PM FINAL
 Site Code : 00000077
 Start Date : 6/4/2013
 Page No : 1

Groups Printed- Bikes

Start Time	EL CAMINO REAL Southbound					GLENWOOD AVE Westbound					EL CAMINO REAL Northbound					VALPARAISO AVE Eastbound					Int. Total
	Right	Thru	Left	Peds	App. Total	Right	Thru	Left	Peds	App. Total	Right	Thru	Left	Peds	App. Total	Right	Thru	Left	Peds	App. Total	
04:00 PM	0	0	0	0	0	0	0	0	0	0	0	2	0	0	2	0	2	0	0	2	4
04:15 PM	0	1	0	0	1	0	0	0	0	0	0	0	0	0	0	0	0	1	0	1	2
04:30 PM	0	0	0	0	0	0	0	0	0	0	0	4	0	0	4	0	1	0	0	1	5
04:45 PM	0	0	0	0	0	0	0	0	0	0	0	3	0	0	3	0	1	0	0	1	4
Total	0	1	0	0	1	0	0	0	0	0	0	9	0	0	9	0	4	1	0	5	15
05:00 PM	0	1	0	0	1	0	0	0	0	0	0	2	0	0	2	0	2	0	0	2	5
05:15 PM	0	0	0	0	0	0	6	0	0	6	0	4	1	0	5	0	0	0	0	0	11
05:30 PM	0	0	0	0	0	0	4	0	0	4	0	4	0	0	4	0	1	0	0	1	9
05:45 PM	0	0	0	0	0	0	2	0	0	2	0	3	0	0	3	0	3	0	0	3	8
Total	0	1	0	0	1	0	12	0	0	12	0	13	1	0	14	0	6	0	0	6	33
Grand Total	0	2	0	0	2	0	12	0	0	12	0	22	1	0	23	0	10	1	0	11	48
Apprch %	0	100	0	0		0	100	0	0		0	95.7	4.3	0		0	90.9	9.1	0		
Total %	0	4.2	0	0	4.2	0	25	0	0	25	0	45.8	2.1	0	47.9	0	20.8	2.1	0	22.9	

Start Time	EL CAMINO REAL Southbound					GLENWOOD AVE Westbound					EL CAMINO REAL Northbound					VALPARAISO AVE Eastbound					Int. Total
	Right	Thru	Left	Peds	App. Total	Right	Thru	Left	Peds	App. Total	Right	Thru	Left	Peds	App. Total	Right	Thru	Left	Peds	App. Total	
05:00 PM	0	1	0	0	1	0	0	0	0	0	0	2	0	0	2	0	2	0	0	2	5
05:15 PM	0	0	0	0	0	0	6	0	0	6	0	4	1	0	5	0	0	0	0	0	11
05:30 PM	0	0	0	0	0	0	4	0	0	4	0	4	0	0	4	0	1	0	0	1	9
05:45 PM	0	0	0	0	0	0	2	0	0	2	0	3	0	0	3	0	3	0	0	3	8
Total Volume	0	1	0	0	1	0	12	0	0	12	0	13	1	0	14	0	6	0	0	6	33
% App. Total	0	100	0	0		0	100	0	0		0	92.9	7.1	0		0	100	0	0		
PHF	.000	.250	.000	.000	.250	.000	.500	.000	.000	.500	.000	.813	.250	.000	.700	.000	.500	.000	.000	.500	.750

Peak Hour Analysis From 04:00 PM to 05:45 PM - Peak 1 of 1

Peak Hour for Entire Intersection Begins at 05:00 PM

Traffic Data Service

Campbell, CA
(408) 377-2988
tdsbay@cs.com

File Name : 77PM FINAL
Site Code : 00000077
Start Date : 6/4/2013
Page No : 2

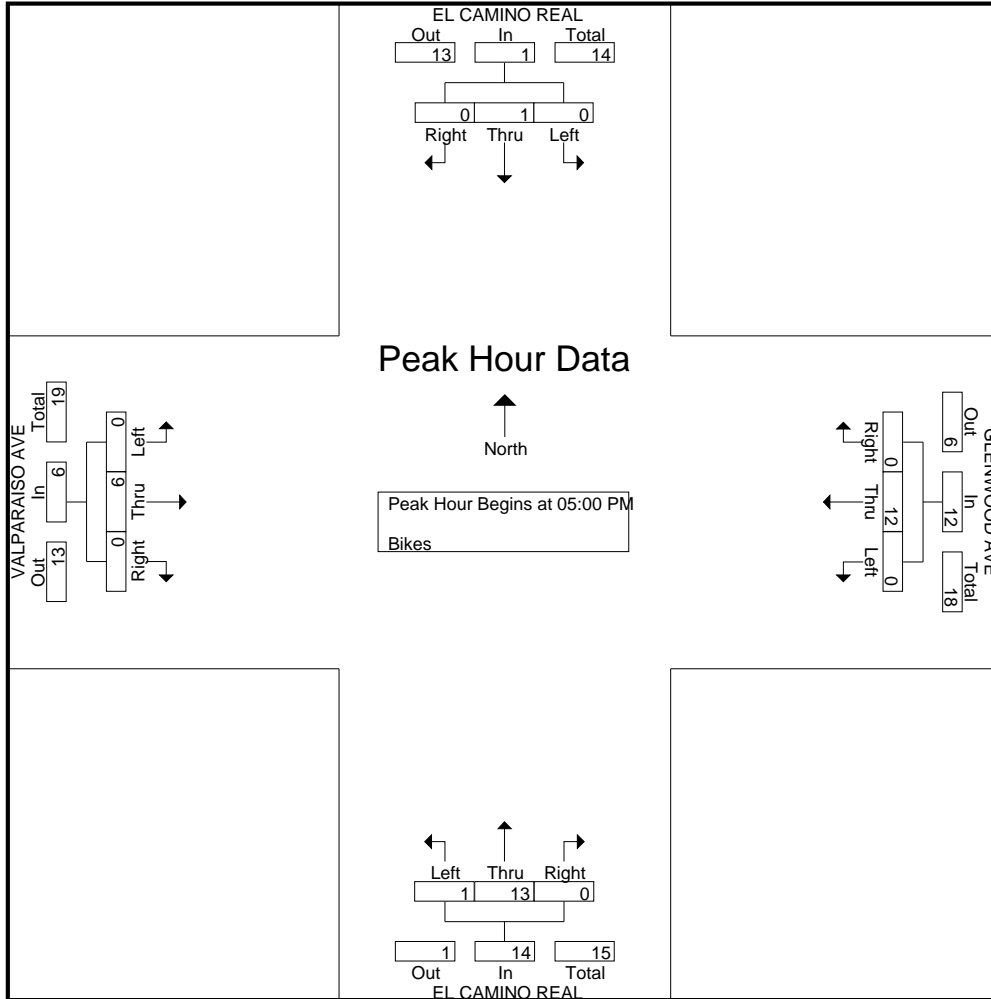

Traffic Data Service

Campbell, CA
 (408) 377-2988
 tdsbay@cs.com

File Name : 78AM FINAL
 Site Code : 00000078
 Start Date : 6/4/2013
 Page No : 1

Groups Printed- Vehicles

Start Time	EL CAMINO REAL Southbound					OAK GROVE AVE Westbound					EL CAMINO REAL Northbound					OAK GROVE AVE Eastbound					Int. Total
	Right	Thru	Left	Peds	App. Total	Right	Thru	Left	Peds	App. Total	Right	Thru	Left	Peds	App. Total	Right	Thru	Left	Peds	App. Total	
07:00 AM	7	183	14	1	205	10	26	12	1	49	10	71	13	1	95	5	18	3	1	27	376
07:15 AM	12	254	21	3	290	6	21	12	7	46	12	115	13	3	143	3	14	7	0	24	503
07:30 AM	19	293	29	7	348	9	51	25	2	87	21	160	17	3	201	11	32	8	3	54	690
07:45 AM	23	336	29	0	388	11	51	31	1	94	16	154	21	11	202	17	40	16	1	74	758
Total	61	1066	93	11	1231	36	149	80	11	276	59	500	64	18	641	36	104	34	5	179	2327
08:00 AM	21	288	19	2	330	13	63	27	2	105	19	160	19	4	202	6	52	14	0	72	709
08:15 AM	19	348	26	6	399	12	41	33	1	87	22	154	17	2	195	16	39	19	5	79	760
08:30 AM	15	346	28	7	396	9	45	29	2	85	20	169	24	5	218	15	42	11	1	69	768
08:45 AM	12	329	29	2	372	5	49	20	2	76	12	162	27	6	207	11	40	16	2	69	724
Total	67	1311	102	17	1497	39	198	109	7	353	73	645	87	17	822	48	173	60	8	289	2961
Grand Total	128	2377	195	28	2728	75	347	189	18	629	132	1145	151	35	1463	84	277	94	13	468	5288
Apprch %	4.7	87.1	7.1	1		11.9	55.2	30	2.9		9	78.3	10.3	2.4		17.9	59.2	20.1	2.8		
Total %	2.4	45	3.7	0.5	51.6	1.4	6.6	3.6	0.3	11.9	2.5	21.7	2.9	0.7	27.7	1.6	5.2	1.8	0.2	8.9	

Start Time	EL CAMINO REAL Southbound				OAK GROVE AVE Westbound				EL CAMINO REAL Northbound				OAK GROVE AVE Eastbound				Int. Total
	Right	Thru	Left	App. Total	Right	Thru	Left	App. Total	Right	Thru	Left	App. Total	Right	Thru	Left	App. Total	
07:45 AM	23	336	29	388	11	51	31	93	16	154	21	191	17	40	16	73	745
08:00 AM	21	288	19	328	13	63	27	103	19	160	19	198	6	52	14	72	701
08:15 AM	19	348	26	393	12	41	33	86	22	154	17	193	16	39	19	74	746
08:30 AM	15	346	28	389	9	45	29	83	20	169	24	213	15	42	11	68	753
Total Volume	78	1318	102	1498	45	200	120	365	77	637	81	795	54	173	60	287	2945
% App. Total	5.2	88	6.8		12.3	54.8	32.9		9.7	80.1	10.2		18.8	60.3	20.9		
PHF	.848	.947	.879	.953	.865	.794	.909	.886	.875	.942	.844	.933	.794	.832	.789	.970	.978

Peak Hour Analysis From 07:00 AM to 08:45 AM - Peak 1 of 1

Peak Hour for Entire Intersection Begins at 07:45 AM

Traffic Data Service

Campbell, CA
 (408) 377-2988
 tdsbay@cs.com

File Name : 78AM FINAL
 Site Code : 00000078
 Start Date : 6/4/2013
 Page No : 2

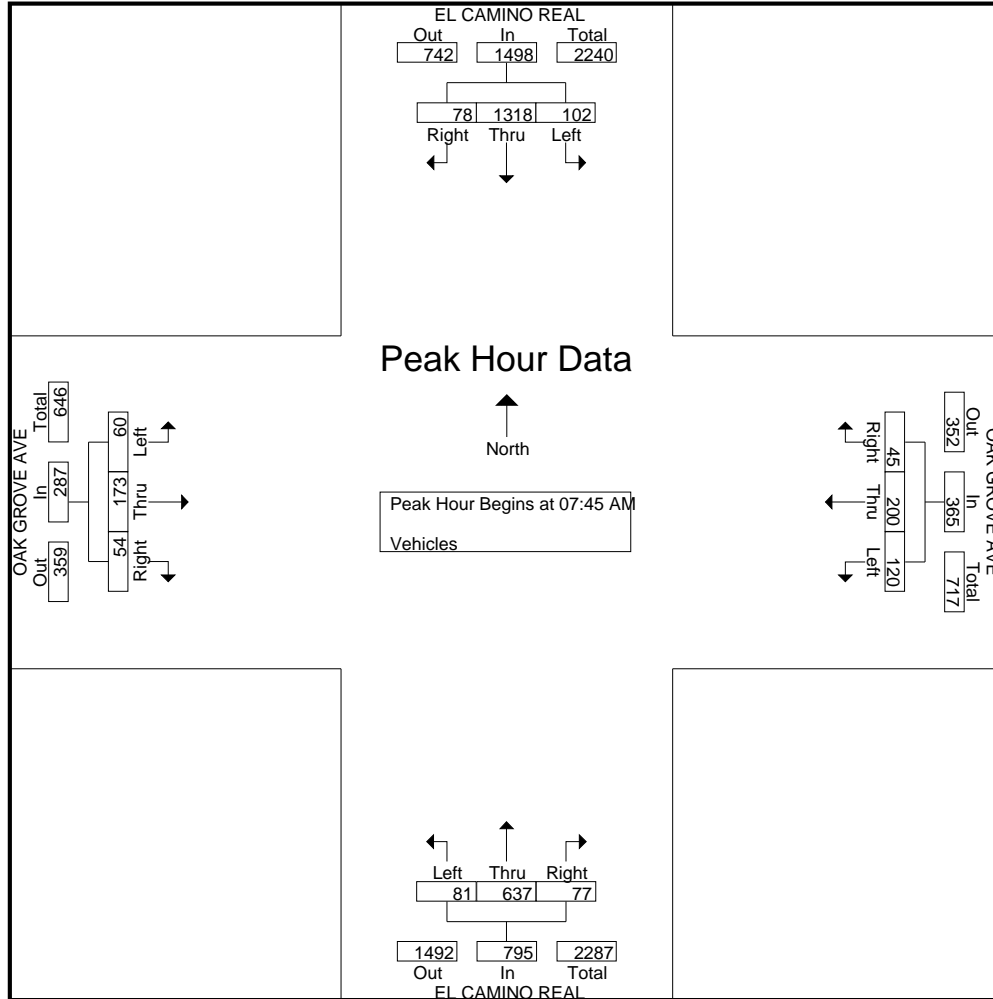

Traffic Data Service

Campbell, CA
 (408) 377-2988
 tdsbay@cs.com

File Name : 78AM FINAL
 Site Code : 00000078
 Start Date : 6/4/2013
 Page No : 1

Groups Printed- Bikes

Start Time	EL CAMINO REAL Southbound					OAK GROVE AVE Westbound					EL CAMINO REAL Northbound					OAK GROVE AVE Eastbound					Int. Total
	Right	Thru	Left	Peds	App. Total	Right	Thru	Left	Peds	App. Total	Right	Thru	Left	Peds	App. Total	Right	Thru	Left	Peds	App. Total	
07:00 AM	0	0	1	0	1	0	0	0	0	0	0	0	0	0	0	0	2	1	0	3	4
07:15 AM	0	1	0	0	1	0	3	0	0	3	0	1	0	0	1	1	3	0	0	4	9
07:30 AM	0	3	0	0	3	0	1	0	0	1	0	0	0	0	0	0	0	0	0	0	4
07:45 AM	0	0	0	0	0	0	11	0	0	11	0	0	0	0	0	0	3	0	0	3	14
Total	0	4	1	0	5	0	15	0	0	15	0	1	0	0	1	1	8	1	0	10	31
08:00 AM	0	3	0	0	3	0	4	0	0	4	0	0	0	0	0	0	2	2	0	4	11
08:15 AM	0	3	1	0	4	0	3	0	0	3	0	1	0	0	1	0	0	0	0	0	8
08:30 AM	0	2	0	0	2	0	1	1	0	2	0	0	0	0	0	0	4	0	0	4	8
08:45 AM	0	3	0	0	3	0	1	0	0	1	0	0	0	0	0	0	0	0	0	0	4
Total	0	11	1	0	12	0	9	1	0	10	0	1	0	0	1	0	6	2	0	8	31
Grand Total	0	15	2	0	17	0	24	1	0	25	0	2	0	0	2	1	14	3	0	18	62
Apprch %	0	88.2	11.8	0		0	96	4	0		0	100	0	0		5.6	77.8	16.7	0		
Total %	0	24.2	3.2	0	27.4	0	38.7	1.6	0	40.3	0	3.2	0	0	3.2	1.6	22.6	4.8	0	29	

Start Time	EL CAMINO REAL Southbound					OAK GROVE AVE Westbound					EL CAMINO REAL Northbound					OAK GROVE AVE Eastbound					Int. Total
	Right	Thru	Left	Peds	App. Total	Right	Thru	Left	Peds	App. Total	Right	Thru	Left	Peds	App. Total	Right	Thru	Left	Peds	App. Total	
07:45 AM	0	0	0	0	0	0	11	0	0	11	0	0	0	0	0	0	3	0	0	3	14
08:00 AM	0	3	0	0	3	0	4	0	0	4	0	0	0	0	0	0	2	2	0	4	11
08:15 AM	0	3	1	0	4	0	3	0	0	3	0	1	0	0	1	0	0	0	0	0	8
08:30 AM	0	2	0	0	2	0	1	1	0	2	0	0	0	0	0	0	4	0	0	4	8
Total Volume	0	8	1	0	9	0	19	1	0	20	0	1	0	0	1	0	9	2	0	11	41
% App. Total	0	88.9	11.1	0		0	95	5	0		0	100	0	0		0	81.8	18.2	0		
PHF	.000	.667	.250	.563		.000	.432	.250	.455		.000	.250	.000	.250		.000	.563	.250	.688		.732

Peak Hour Analysis From 07:00 AM to 08:45 AM - Peak 1 of 1

Peak Hour for Entire Intersection Begins at 07:45 AM

Traffic Data Service

Campbell, CA
(408) 377-2988
tdsbay@cs.com

File Name : 78AM FINAL
Site Code : 00000078
Start Date : 6/4/2013
Page No : 2

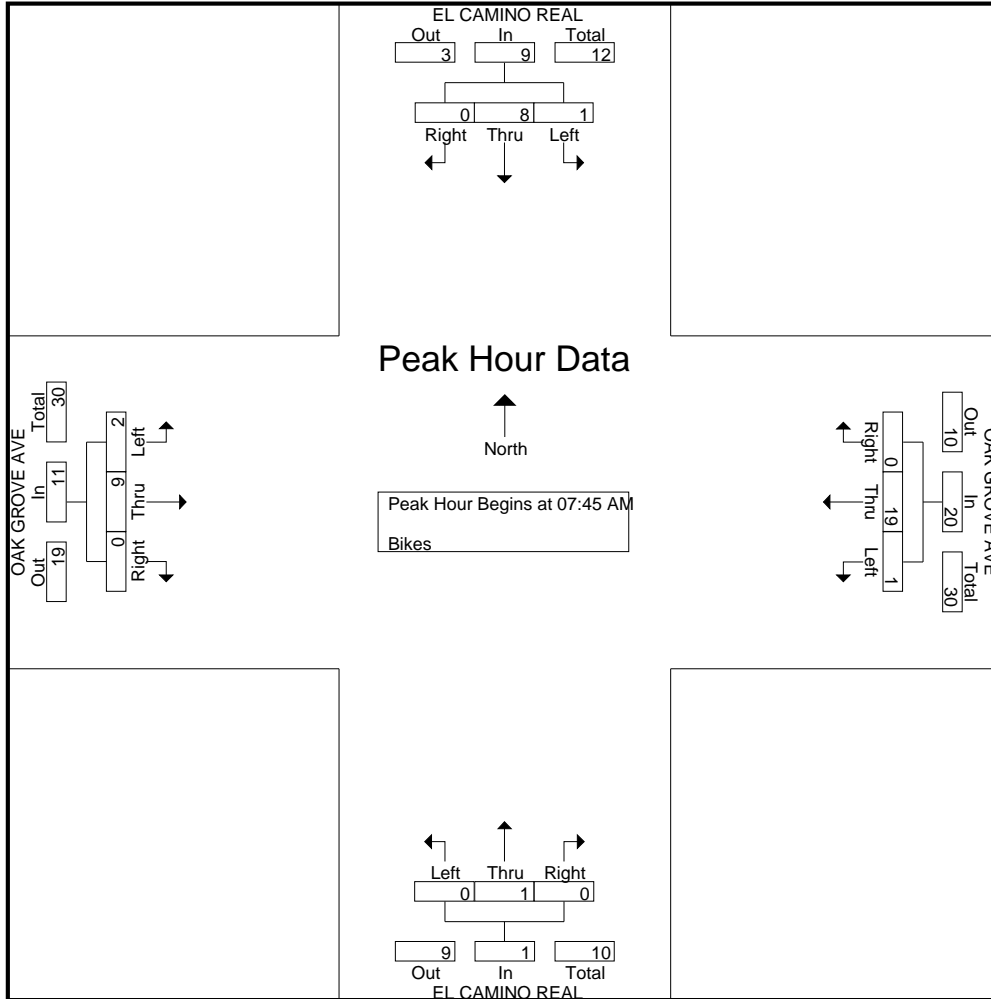

Traffic Data Service

Campbell, CA
 (408) 377-2988
 tdsbay@cs.com

File Name : 78PM FINAL
 Site Code : 00000078
 Start Date : 6/4/2013
 Page No : 1

Groups Printed- Vehicles

Start Time	EL CAMINO REAL Southbound					OAK GROVE AVE Westbound					EL CAMINO REAL Northbound					OAK GROVE AVE Eastbound					Int. Total
	Right	Thru	Left	Peds	App. Total	Right	Thru	Left	Peds	App. Total	Right	Thru	Left	Peds	App. Total	Right	Thru	Left	Peds	App. Total	
04:00 PM	19	202	24	6	251	14	51	15	1	81	22	310	43	16	391	29	54	24	2	109	832
04:15 PM	18	228	21	1	268	15	42	23	1	81	33	320	34	9	396	27	28	33	3	91	836
04:30 PM	24	211	26	4	265	17	53	16	0	86	32	335	21	12	400	29	33	22	4	88	839
04:45 PM	31	231	26	4	292	17	44	28	2	91	24	356	31	23	434	24	50	33	4	111	928
Total	92	872	97	15	1076	63	190	82	4	339	111	1321	129	60	1621	109	165	112	13	399	3435
05:00 PM	21	235	20	3	279	27	51	22	1	101	28	362	31	12	433	27	57	34	3	121	934
05:15 PM	18	203	30	5	256	17	46	24	5	92	26	369	27	11	433	24	59	30	4	117	898
05:30 PM	20	231	28	7	286	19	40	24	5	88	21	394	20	5	440	26	50	21	4	101	915
05:45 PM	22	249	22	2	295	21	37	30	4	92	25	347	35	8	415	22	43	27	6	98	900
Total	81	918	100	17	1116	84	174	100	15	373	100	1472	113	36	1721	99	209	112	17	437	3647
Grand Total	173	1790	197	32	2192	147	364	182	19	712	211	2793	242	96	3342	208	374	224	30	836	7082
Apprch %	7.9	81.7	9	1.5		20.6	51.1	25.6	2.7		6.3	83.6	7.2	2.9		24.9	44.7	26.8	3.6		
Total %	2.4	25.3	2.8	0.5	31	2.1	5.1	2.6	0.3	10.1	3	39.4	3.4	1.4	47.2	2.9	5.3	3.2	0.4	11.8	

Start Time	EL CAMINO REAL Southbound				OAK GROVE AVE Westbound				EL CAMINO REAL Northbound				OAK GROVE AVE Eastbound				Int. Total
	Right	Thru	Left	App. Total	Right	Thru	Left	App. Total	Right	Thru	Left	App. Total	Right	Thru	Left	App. Total	
04:45 PM	31	231	26	288	17	44	28	89	24	356	31	411	24	50	33	107	895
05:00 PM	21	235	20	276	27	51	22	100	28	362	31	421	27	57	34	118	915
05:15 PM	18	203	30	251	17	46	24	87	26	369	27	422	24	59	30	113	873
05:30 PM	20	231	28	279	19	40	24	83	21	394	20	435	26	50	21	97	894
Total Volume	90	900	104	1094	80	181	98	359	99	1481	109	1689	101	216	118	435	3577
% App. Total	8.2	82.3	9.5		22.3	50.4	27.3		5.9	87.7	6.5		23.2	49.7	27.1		
PHF	.726	.957	.867	.950	.741	.887	.875	.898	.884	.940	.879	.971	.935	.915	.868	.922	.977

Peak Hour Analysis From 04:00 PM to 05:45 PM - Peak 1 of 1

Peak Hour for Entire Intersection Begins at 04:45 PM

Traffic Data Service

Campbell, CA
(408) 377-2988
tdsbay@cs.com

File Name : 78PM FINAL
Site Code : 00000078
Start Date : 6/4/2013
Page No : 2

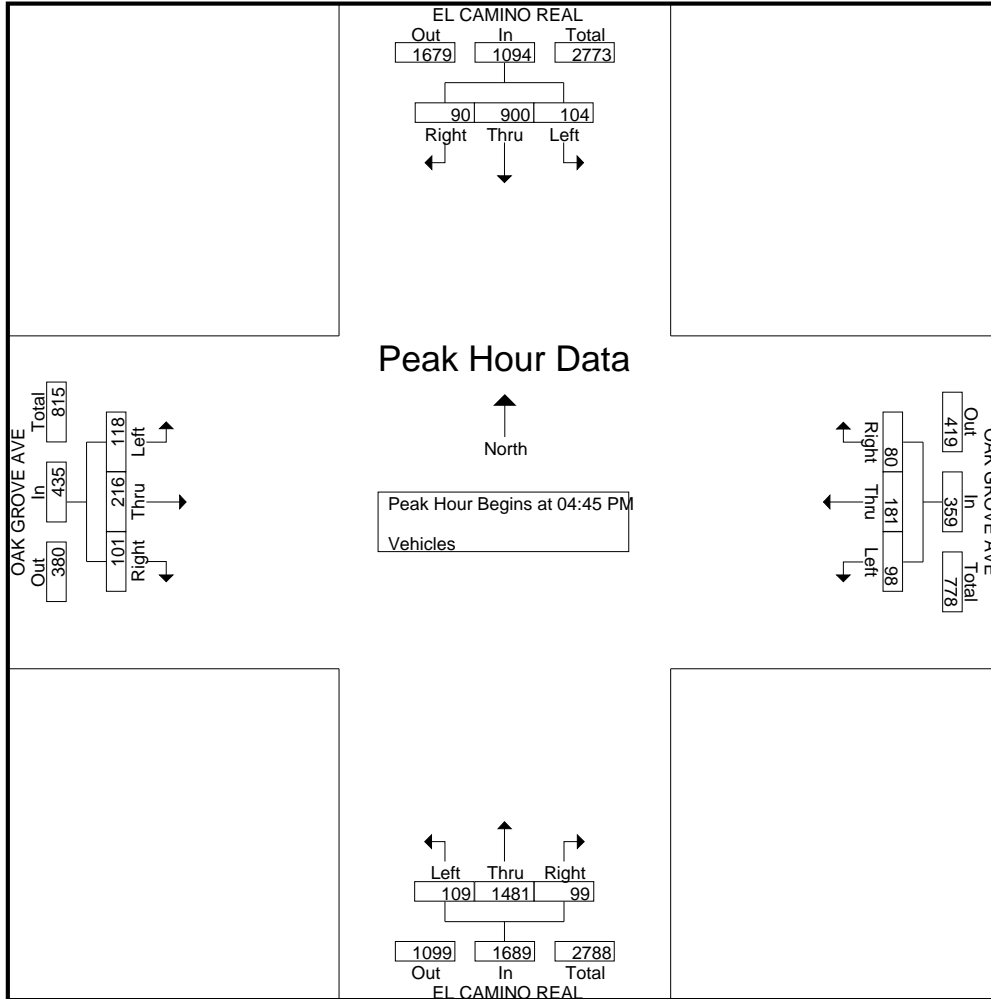

Traffic Data Service

Campbell, CA
 (408) 377-2988
 tdsbay@cs.com

File Name : 78PM FINAL
 Site Code : 00000078
 Start Date : 6/4/2013
 Page No : 1

Groups Printed- Bikes

Start Time	EL CAMINO REAL Southbound					OAK GROVE AVE Westbound					EL CAMINO REAL Northbound					OAK GROVE AVE Eastbound					Int. Total
	Right	Thru	Left	Peds	App. Total	Right	Thru	Left	Peds	App. Total	Right	Thru	Left	Peds	App. Total	Right	Thru	Left	Peds	App. Total	
04:00 PM	0	0	0	0	0	0	1	1	0	2	0	0	0	0	0	0	1	0	0	1	3
04:15 PM	0	1	0	0	1	0	4	0	0	4	0	1	0	0	1	0	2	0	0	2	8
04:30 PM	0	0	0	0	0	0	1	0	0	1	0	0	0	0	0	0	1	0	0	1	2
04:45 PM	0	0	0	0	0	0	2	0	0	2	0	1	0	0	1	0	1	0	0	1	4
Total	0	1	0	0	1	0	8	1	0	9	0	2	0	0	2	0	5	0	0	5	17
05:00 PM	0	2	0	0	2	0	2	0	0	2	0	2	0	0	2	0	2	0	0	2	8
05:15 PM	0	0	0	0	0	1	3	0	0	4	0	2	0	0	2	0	4	0	0	4	10
05:30 PM	0	0	0	0	0	0	1	1	0	2	0	1	0	0	1	0	0	0	0	0	3
05:45 PM	0	1	0	0	1	0	4	0	0	4	0	1	0	0	1	0	1	0	0	1	7
Total	0	3	0	0	3	1	10	1	0	12	0	6	0	0	6	0	7	0	0	7	28
Grand Total	0	4	0	0	4	1	18	2	0	21	0	8	0	0	8	0	12	0	0	12	45
Apprch %	0	100	0	0		4.8	85.7	9.5	0		0	100	0	0		0	100	0	0		
Total %	0	8.9	0	0	8.9	2.2	40	4.4	0	46.7	0	17.8	0	0	17.8	0	26.7	0	0	26.7	

Start Time	EL CAMINO REAL Southbound				OAK GROVE AVE Westbound				EL CAMINO REAL Northbound				OAK GROVE AVE Eastbound				Int. Total
	Right	Thru	Left	App. Total	Right	Thru	Left	App. Total	Right	Thru	Left	App. Total	Right	Thru	Left	App. Total	
05:00 PM	0	2	0	2	0	2	0	2	0	2	0	2	0	2	0	2	8
05:15 PM	0	0	0	0	1	3	0	4	0	2	0	2	0	4	0	4	10
05:30 PM	0	0	0	0	0	1	1	2	0	1	0	1	0	0	0	0	3
05:45 PM	0	1	0	1	0	4	0	4	0	1	0	1	0	1	0	1	7
Total Volume	0	3	0	3	1	10	1	12	0	6	0	6	0	7	0	7	28
% App. Total	0	100	0		8.3	83.3	8.3		0	100	0		0	100	0		
PHF	.000	.375	.000	.375	.250	.625	.250	.750	.000	.750	.000	.750	.000	.438	.000	.438	.700

Peak Hour Analysis From 04:00 PM to 05:45 PM - Peak 1 of 1

Peak Hour for Entire Intersection Begins at 05:00 PM

Traffic Data Service

Campbell, CA
(408) 377-2988
tdsbay@cs.com

File Name : 78PM FINAL
Site Code : 00000078
Start Date : 6/4/2013
Page No : 2

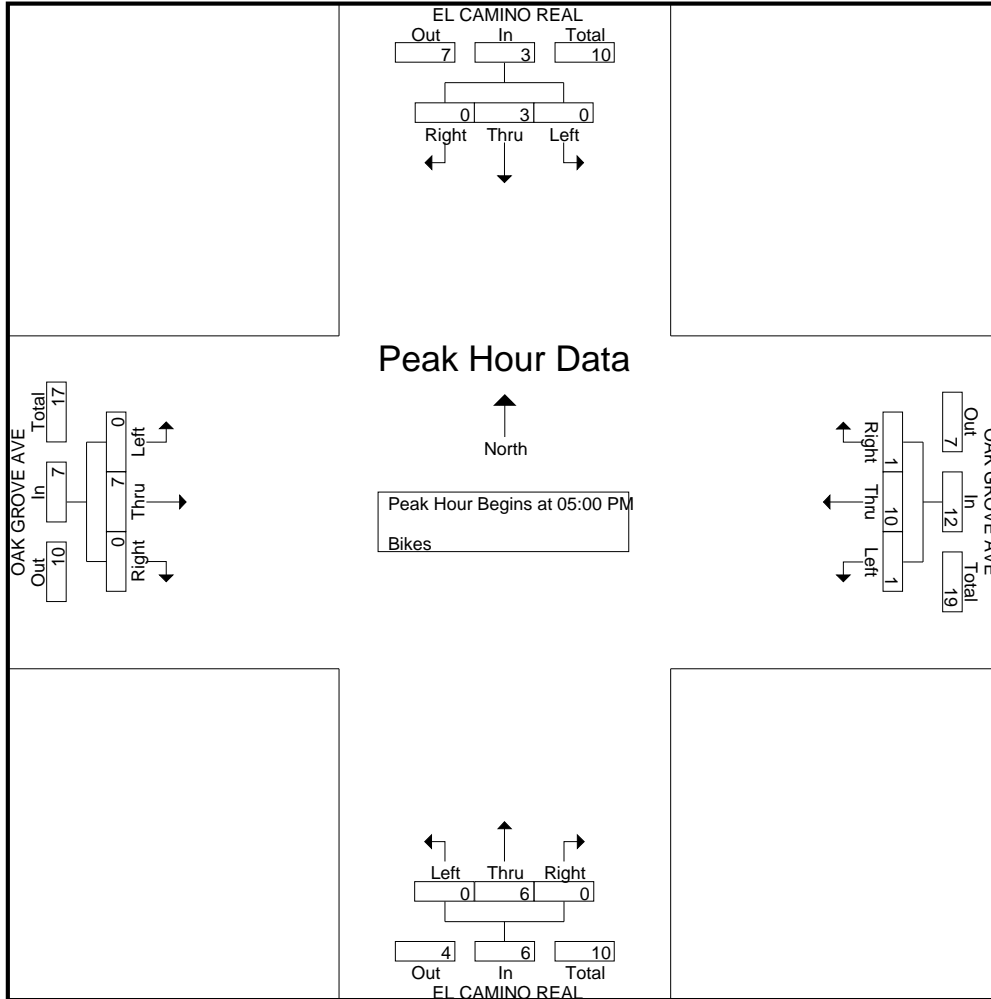

Traffic Data Service

Campbell, CA
 (408) 377-2988
 tdsbay@cs.com

File Name : 20AM FINAL
 Site Code : 00000020
 Start Date : 5/22/2013
 Page No : 1

Groups Printed- Vehicles

Start Time	EL CAMINO REAL Southbound					SANTA CRUZ AVE Westbound					EL CAMINO REAL Northbound					SANTA CRUZ AVE Eastbound					Int. Total
	Right	Thru	Left	Peds	App. Total	Right	Thru	Left	Peds	App. Total	Right	Thru	Left	Peds	App. Total	Right	Thru	Left	Peds	App. Total	
07:00 AM	12	170	1	3	186	4	7	7	0	18	2	101	1	1	105	13	6	7	0	26	335
07:15 AM	20	261	4	3	288	8	9	6	2	25	4	140	0	7	151	16	10	14	1	41	505
07:30 AM	20	313	0	4	337	2	11	8	0	21	8	181	0	10	199	20	8	15	2	45	602
07:45 AM	19	361	0	6	386	13	7	8	7	35	10	172	0	16	198	21	12	22	0	55	674
Total	71	1105	5	16	1197	27	34	29	9	99	24	594	1	34	653	70	36	58	3	167	2116
08:00 AM	30	335	0	5	370	7	22	11	8	48	7	168	0	11	186	15	15	27	5	62	666
08:15 AM	20	286	0	8	314	7	10	18	5	40	9	177	0	15	201	15	21	17	1	54	609
08:30 AM	16	369	0	8	393	5	15	16	2	38	17	209	0	8	234	18	10	30	2	60	725
08:45 AM	21	371	0	9	401	7	17	17	0	41	13	218	0	3	234	20	15	25	4	64	740
Total	87	1361	0	30	1478	26	64	62	15	167	46	772	0	37	855	68	61	99	12	240	2740
Grand Total	158	2466	5	46	2675	53	98	91	24	266	70	1366	1	71	1508	138	97	157	15	407	4856
Apprch %	5.9	92.2	0.2	1.7		19.9	36.8	34.2	9		4.6	90.6	0.1	4.7		33.9	23.8	38.6	3.7		
Total %	3.3	50.8	0.1	0.9	55.1	1.1	2	1.9	0.5	5.5	1.4	28.1	0	1.5	31.1	2.8	2	3.2	0.3	8.4	

Start Time	EL CAMINO REAL Southbound				SANTA CRUZ AVE Westbound				EL CAMINO REAL Northbound				SANTA CRUZ AVE Eastbound				Int. Total
	Right	Thru	Left	App. Total	Right	Thru	Left	App. Total	Right	Thru	Left	App. Total	Right	Thru	Left	App. Total	
Peak Hour Analysis From 07:00 AM to 08:45 AM - Peak 1 of 1																	
Peak Hour for Entire Intersection Begins at 08:00 AM																	
08:00 AM	30	335	0	365	7	22	11	40	7	168	0	175	15	15	27	57	637
08:15 AM	20	286	0	306	7	10	18	35	9	177	0	186	15	21	17	53	580
08:30 AM	16	369	0	385	5	15	16	36	17	209	0	226	18	10	30	58	705
08:45 AM	21	371	0	392	7	17	17	41	13	218	0	231	20	15	25	60	724
Total Volume	87	1361	0	1448	26	64	62	152	46	772	0	818	68	61	99	228	2646
% App. Total	6	94	0		17.1	42.1	40.8		5.6	94.4	0		29.8	26.8	43.4		
PHF	.725	.917	.000	.923	.929	.727	.861	.927	.676	.885	.000	.885	.850	.726	.825	.950	.914

Traffic Data Service

Campbell, CA
 (408) 377-2988
 tdsbay@cs.com

File Name : 20AM FINAL
 Site Code : 00000020
 Start Date : 5/22/2013
 Page No : 2

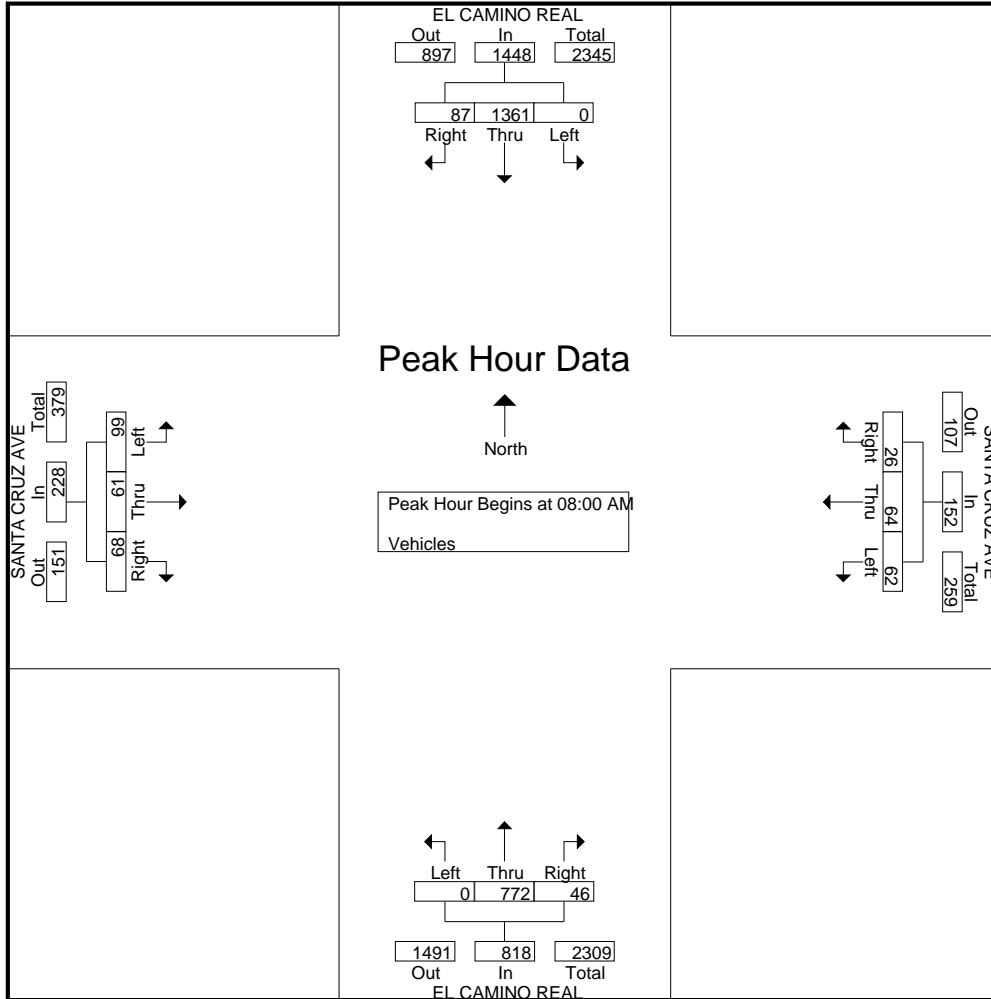

Traffic Data Service

Campbell, CA
 (408) 377-2988
 tdsbay@cs.com

File Name : 20PM FINAL
 Site Code : 00000020
 Start Date : 5/22/2013
 Page No : 1

Groups Printed- Vehicles

Start Time	EL CAMINO REAL Southbound					SANTA CRUZ AVE Westbound					EL CAMINO REAL Northbound					SANTA CRUZ AVE Eastbound					Int. Total
	Right	Thru	Left	Peds	App. Total	Right	Thru	Left	Peds	App. Total	Right	Thru	Left	Peds	App. Total	Right	Thru	Left	Peds	App. Total	
04:00 PM	28	242	0	9	279	11	12	10	7	40	12	304	0	13	329	32	14	28	3	77	725
04:15 PM	30	275	0	4	309	6	8	17	5	36	12	353	0	18	383	32	10	34	5	81	809
04:30 PM	34	238	0	7	279	3	20	12	4	39	19	358	0	13	390	23	15	37	0	75	783
04:45 PM	30	255	0	10	295	11	8	9	3	31	14	298	0	11	323	42	16	40	2	100	749
Total	122	1010	0	30	1162	31	48	48	19	146	57	1313	0	55	1425	129	55	139	10	333	3066
05:00 PM	21	266	0	7	294	16	20	17	2	55	15	331	0	15	361	47	14	38	6	105	815
05:15 PM	22	279	0	8	309	7	12	18	9	46	17	334	0	12	363	37	19	33	3	92	810
05:30 PM	20	303	0	9	332	8	17	26	8	59	19	373	0	16	408	38	19	37	3	97	896
05:45 PM	34	269	0	7	310	14	12	9	11	46	24	379	0	13	416	24	15	27	2	68	840
Total	97	1117	0	31	1245	45	61	70	30	206	75	1417	0	56	1548	146	67	135	14	362	3361
Grand Total	219	2127	0	61	2407	76	109	118	49	352	132	2730	0	111	2973	275	122	274	24	695	6427
Apprch %	9.1	88.4	0	2.5		21.6	31	33.5	13.9		4.4	91.8	0	3.7		39.6	17.6	39.4	3.5		
Total %	3.4	33.1	0	0.9	37.5	1.2	1.7	1.8	0.8	5.5	2.1	42.5	0	1.7	46.3	4.3	1.9	4.3	0.4	10.8	

Start Time	EL CAMINO REAL Southbound					SANTA CRUZ AVE Westbound					EL CAMINO REAL Northbound					SANTA CRUZ AVE Eastbound					Int. Total
	Right	Thru	Left	Peds	App. Total	Right	Thru	Left	Peds	App. Total	Right	Thru	Left	Peds	App. Total	Right	Thru	Left	Peds	App. Total	
Peak Hour Analysis From 04:00 PM to 05:45 PM - Peak 1 of 1																					
Peak Hour for Entire Intersection Begins at 05:00 PM																					
05:00 PM	21	266	0	287	16	20	17	53	15	331	0	346	47	14	38	99	785				
05:15 PM	22	279	0	301	7	12	18	37	17	334	0	351	37	19	33	89	778				
05:30 PM	20	303	0	323	8	17	26	51	19	373	0	392	38	19	37	94	860				
05:45 PM	34	269	0	303	14	12	9	35	24	379	0	403	24	15	27	66	807				
Total Volume	97	1117	0	1214	45	61	70	176	75	1417	0	1492	146	67	135	348	3230				
% App. Total	8	92	0		25.6	34.7	39.8		5	95	0		42	19.3	38.8						
PHF	.713	.922	.000	.940	.703	.763	.673	.830	.781	.935	.000	.926	.777	.882	.888	.879	.939				

Traffic Data Service

Campbell, CA
(408) 377-2988
tdsbay@cs.com

File Name : 20PM FINAL
Site Code : 00000020
Start Date : 5/22/2013
Page No : 2

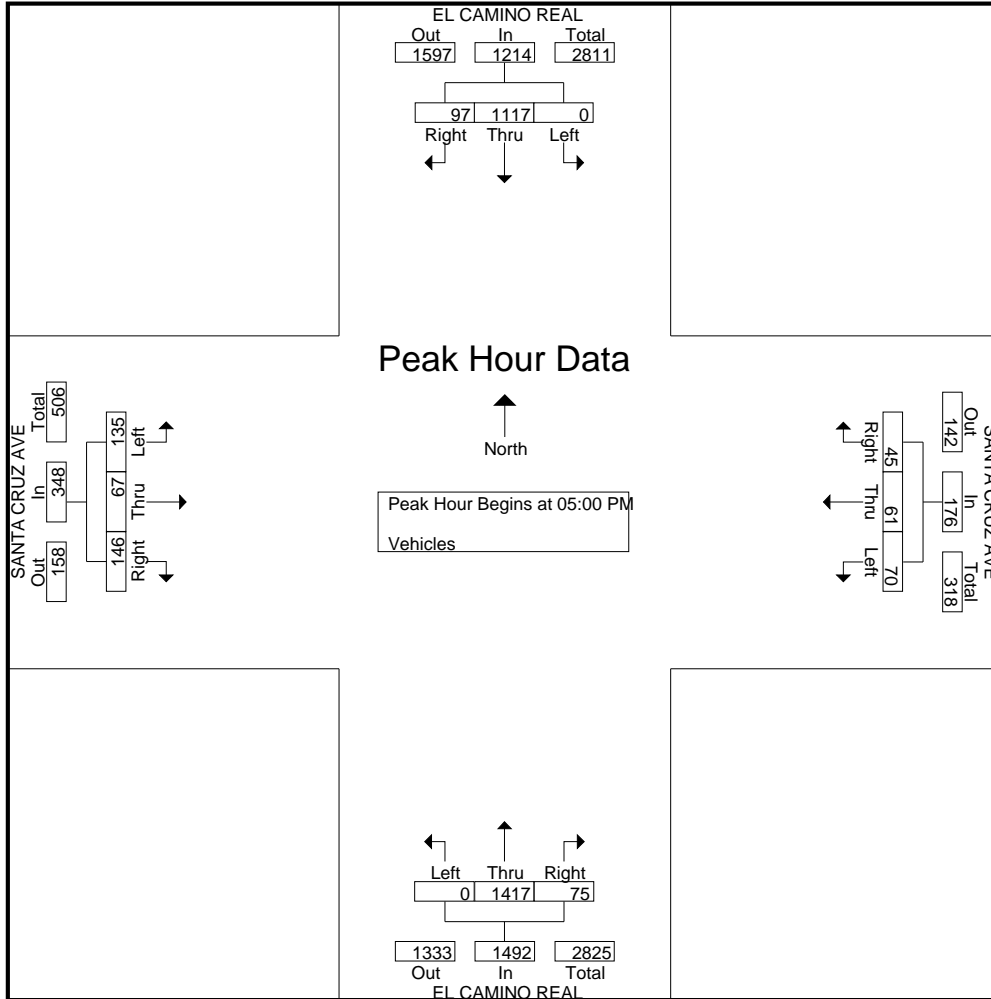

Traffic Data Service

Campbell, CA
(408) 377-2988
tdsbay@cs.com

File Name : 20AM FINAL
Site Code : 00000020
Start Date : 5/22/2013
Page No : 1

Groups Printed- Bikes

Start Time	EL CAMINO REAL Southbound					SANTA CRUZ AVE Westbound					EL CAMINO REAL Northbound					SANTA CRUZ AVE Eastbound					Int. Total
	Right	Thru	Left	Peds	App. Total	Right	Thru	Left	Peds	App. Total	Right	Thru	Left	Peds	App. Total	Right	Thru	Left	Peds	App. Total	
07:00 AM	0	1	0	0	1	0	0	0	0	0	0	0	0	0	0	0	1	0	0	1	2
07:15 AM	1	0	0	0	1	0	1	0	0	1	0	0	0	0	0	0	0	0	0	0	2
07:30 AM	0	2	1	0	3	0	2	1	0	3	0	0	0	0	0	0	1	0	0	1	7
07:45 AM	1	3	0	0	4	0	0	0	0	0	0	0	0	0	0	0	3	0	0	3	7
Total	2	6	1	0	9	0	3	1	0	4	0	0	0	0	0	0	5	0	0	5	18
08:00 AM	0	11	0	0	11	0	4	0	0	4	0	0	0	0	0	0	0	1	0	1	16
08:15 AM	0	3	0	0	3	0	1	0	0	1	1	0	0	0	1	0	0	0	0	0	5
08:30 AM	0	0	0	0	0	0	0	0	0	0	0	0	0	0	0	0	0	0	0	0	0
08:45 AM	0	2	0	0	2	0	0	0	0	0	0	1	0	0	1	0	1	1	0	2	5
Total	0	16	0	0	16	0	5	0	0	5	1	1	0	0	2	0	1	2	0	3	26
Grand Total	2	22	1	0	25	0	8	1	0	9	1	1	0	0	2	0	6	2	0	8	44
Apprch %	8	88	4	0		0	88.9	11.1	0		50	50	0	0		0	75	25	0		
Total %	4.5	50	2.3	0	56.8	0	18.2	2.3	0	20.5	2.3	2.3	0	0	4.5	0	13.6	4.5	0	18.2	

Start Time	EL CAMINO REAL Southbound				SANTA CRUZ AVE Westbound				EL CAMINO REAL Northbound				SANTA CRUZ AVE Eastbound				Int. Total
	Right	Thru	Left	App. Total	Right	Thru	Left	App. Total	Right	Thru	Left	App. Total	Right	Thru	Left	App. Total	
Peak Hour Analysis From 07:00 AM to 08:45 AM - Peak 1 of 1																	
Peak Hour for Entire Intersection Begins at 07:30 AM																	
07:30 AM	0	2	1	3	0	2	1	3	0	0	0	0	0	1	0	1	7
07:45 AM	1	3	0	4	0	0	0	0	0	0	0	0	0	3	0	3	7
08:00 AM	0	11	0	11	0	4	0	4	0	0	0	0	0	0	1	1	16
08:15 AM	0	3	0	3	0	1	0	1	1	0	0	1	0	0	0	0	5
Total Volume	1	19	1	21	0	7	1	8	1	0	0	1	0	4	1	5	35
% App. Total	4.8	90.5	4.8		0	87.5	12.5		100	0	0		0	80	20		
PHF	.250	.432	.250	.477	.000	.438	.250	.500	.250	.000	.000	.250	.000	.333	.250	.417	.547

Traffic Data Service

Campbell, CA
(408) 377-2988
tdsbay@cs.com

File Name : 20AM FINAL
Site Code : 00000020
Start Date : 5/22/2013
Page No : 2

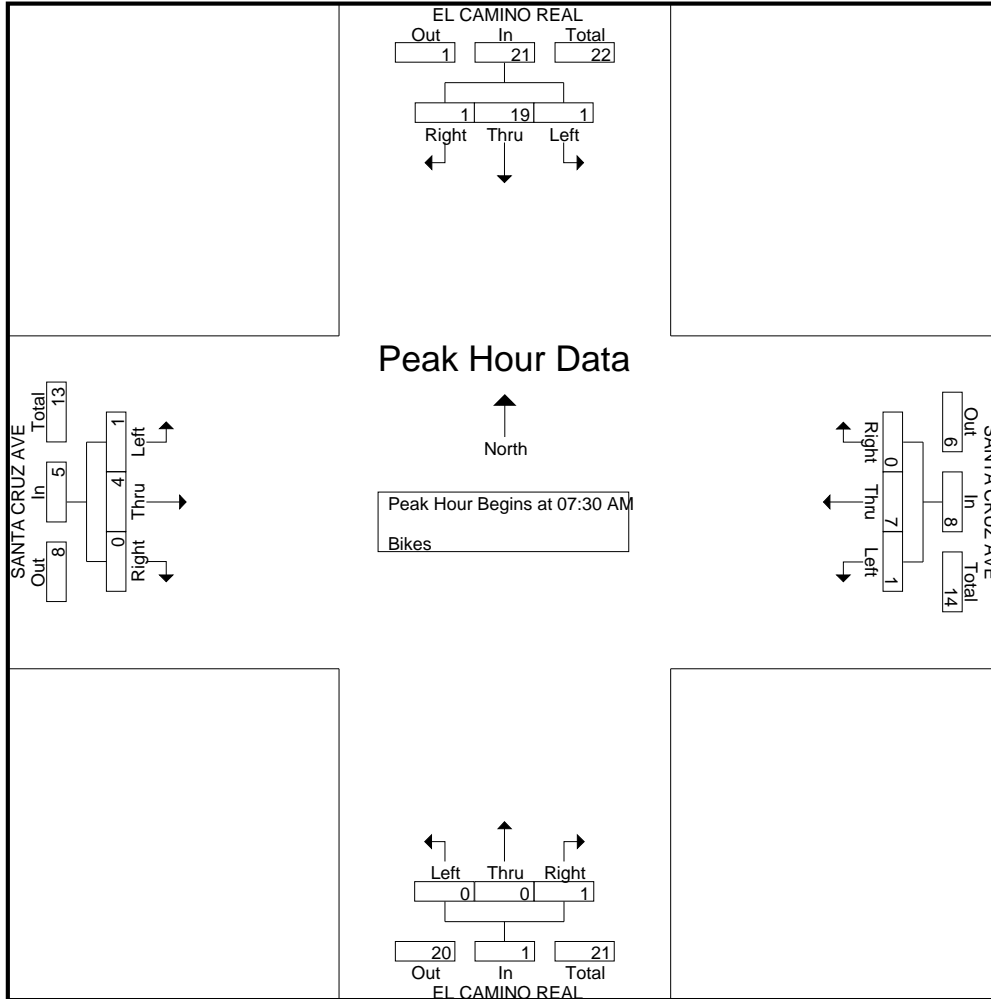

Traffic Data Service

Campbell, CA
 (408) 377-2988
 tdsbay@cs.com

File Name : 20PM FINAL
 Site Code : 00000020
 Start Date : 5/22/2013
 Page No : 1

Groups Printed- Bikes

Start Time	EL CAMINO REAL Southbound					SANTA CRUZ AVE Westbound					EL CAMINO REAL Northbound					SANTA CRUZ AVE Eastbound					Int. Total					
	Right	Thru	Left	Peds	App. Total	Right	Thru	Left	Peds	App. Total	Right	Thru	Left	Peds	App. Total	Right	Thru	Left	Peds	App. Total						
04:00 PM	0	1	0	0	1	0	0	0	0	0	0	0	0	0	0	0	0	0	0	0	0	0	0	0	0	1
04:15 PM	0	0	0	0	0	0	1	0	0	1	0	0	0	0	0	0	0	0	0	0	0	0	0	0	0	1
04:30 PM	0	2	0	0	2	0	0	0	0	0	0	0	0	0	0	0	1	0	0	0	0	1	0	0	1	3
04:45 PM	0	0	0	0	0	0	0	0	0	0	0	0	0	0	0	0	0	1	0	0	0	1	0	0	1	1
Total	0	3	0	0	3	0	1	0	0	1	0	0	0	0	0	0	1	1	0	0	0	2	1	0	6	
05:00 PM	0	0	0	0	0	0	0	0	0	0	0	0	0	0	0	0	0	0	0	0	0	0	0	0	0	0
05:15 PM	0	0	0	0	0	0	0	0	0	0	0	0	0	0	0	0	0	0	0	0	0	0	0	0	0	0
05:30 PM	0	2	0	0	2	0	2	0	0	2	0	1	0	0	1	0	1	0	0	0	0	1	0	0	1	6
05:45 PM	0	0	0	0	0	0	1	0	0	1	0	2	0	0	2	0	1	1	0	0	0	2	1	0	2	5
Total	0	2	0	0	2	0	3	0	0	3	0	3	0	0	3	0	2	1	0	0	0	3	1	0	11	
Grand Total	0	5	0	0	5	0	4	0	0	4	0	3	0	0	3	0	3	2	0	0	0	5	1	0	17	
Apprch %	0	100	0	0		0	100	0	0		0	100	0	0		0	60	40	0		0					
Total %	0	29.4	0	0	29.4	0	23.5	0	0	23.5	0	17.6	0	0	17.6	0	17.6	11.8	0	29.4						

Start Time	EL CAMINO REAL Southbound				SANTA CRUZ AVE Westbound				EL CAMINO REAL Northbound				SANTA CRUZ AVE Eastbound				Int. Total
	Right	Thru	Left	App. Total	Right	Thru	Left	App. Total	Right	Thru	Left	App. Total	Right	Thru	Left	App. Total	
Peak Hour Analysis From 04:00 PM to 05:45 PM - Peak 1 of 1																	
Peak Hour for Entire Intersection Begins at 05:00 PM																	
05:00 PM	0	0	0	0	0	0	0	0	0	0	0	0	0	0	0	0	0
05:15 PM	0	0	0	0	0	0	0	0	0	0	0	0	0	0	0	0	0
05:30 PM	0	2	0	2	0	2	0	2	0	1	0	1	0	1	0	1	6
05:45 PM	0	0	0	0	0	1	0	1	0	2	0	2	0	1	1	2	5
Total Volume	0	2	0	2	0	3	0	3	0	3	0	3	0	2	1	3	11
% App. Total	0	100	0		0	100	0		0	100	0		0	66.7	33.3		
PHF	.000	.250	.000	.250	.000	.375	.000	.375	.000	.375	.000	.375	.000	.500	.250	.375	.458

Traffic Data Service

Campbell, CA
(408) 377-2988
tdsbay@cs.com

File Name : 20PM FINAL
Site Code : 00000020
Start Date : 5/22/2013
Page No : 2

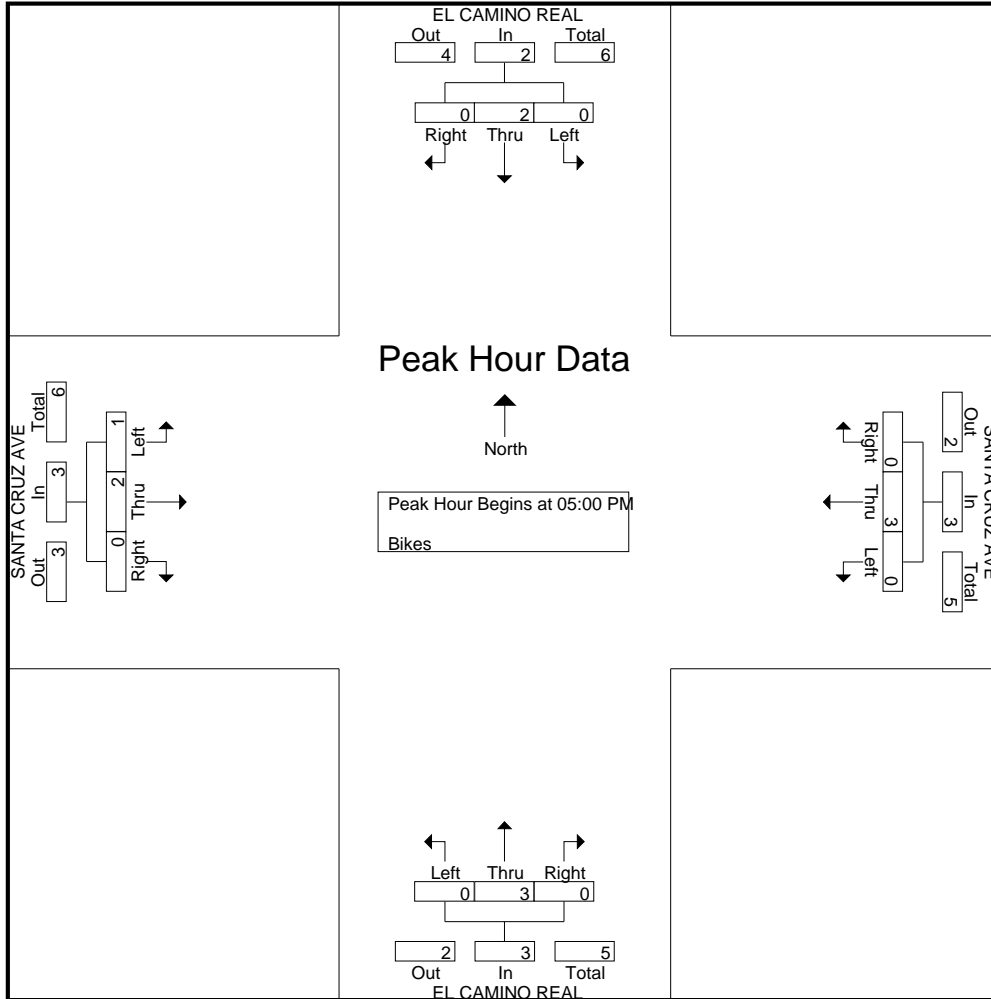

Traffic Data Service

Campbell, CA
 (408) 377-2988
 tdsbay@cs.com

File Name : 80AM FINAL
 Site Code : 00000080
 Start Date : 6/6/2013
 Page No : 1

Groups Printed- Vehicles

Start Time	MERRILL ST Southbound					CALTRAIN DW Westbound					MERRILL ST Northbound					SANTA CRUZ AVE Eastbound					Int. Total
	Right	Thru	Left	Peds	App. Total	Right	Thru	Left	Peds	App. Total	Right	Thru	Left	Peds	App. Total	Right	Thru	Left	Peds	App. Total	
07:00 AM	5	3	0	3	11	0	0	0	2	2	0	1	4	6	11	1	0	1	3	5	29
07:15 AM	7	5	3	10	25	0	0	0	6	6	1	1	12	9	23	3	0	7	5	15	69
07:30 AM	17	4	2	13	36	2	2	0	5	9	0	4	9	5	18	4	0	10	10	24	87
07:45 AM	20	5	2	6	33	2	1	0	5	8	0	3	5	11	19	0	0	21	7	28	88
Total	49	17	7	32	105	4	3	0	18	25	1	9	30	31	71	8	0	39	25	72	273
08:00 AM	16	5	0	4	25	0	1	0	5	6	0	7	10	5	22	1	0	12	1	14	67
08:15 AM	16	5	2	9	32	4	2	0	3	9	0	0	13	10	23	3	4	22	6	35	99
08:30 AM	21	7	1	12	41	1	0	1	10	12	1	4	15	25	45	5	1	21	5	32	130
08:45 AM	22	5	1	9	37	2	2	0	3	7	0	4	17	7	28	1	1	11	12	25	97
Total	75	22	4	34	135	7	5	1	21	34	1	15	55	47	118	10	6	66	24	106	393
Grand Total	124	39	11	66	240	11	8	1	39	59	2	24	85	78	189	18	6	105	49	178	666
Apprch %	51.7	16.2	4.6	27.5		18.6	13.6	1.7	66.1		1.1	12.7	45	41.3		10.1	3.4	59	27.5		
Total %	18.6	5.9	1.7	9.9	36	1.7	1.2	0.2	5.9	8.9	0.3	3.6	12.8	11.7	28.4	2.7	0.9	15.8	7.4	26.7	

Start Time	MERRILL ST Southbound				CALTRAIN DW Westbound				MERRILL ST Northbound				SANTA CRUZ AVE Eastbound				Int. Total
	Right	Thru	Left	App. Total	Right	Thru	Left	App. Total	Right	Thru	Left	App. Total	Right	Thru	Left	App. Total	
Peak Hour Analysis From 07:00 AM to 08:45 AM - Peak 1 of 1																	
Peak Hour for Entire Intersection Begins at 08:00 AM																	
08:00 AM	16	5	0	21	0	1	0	1	0	7	10	17	1	0	12	13	52
08:15 AM	16	5	2	23	4	2	0	6	0	0	13	13	3	4	22	29	71
08:30 AM	21	7	1	29	1	0	1	2	1	4	15	20	5	1	21	27	78
08:45 AM	22	5	1	28	2	2	0	4	0	4	17	21	1	1	11	13	66
Total Volume	75	22	4	101	7	5	1	13	1	15	55	71	10	6	66	82	267
% App. Total	74.3	21.8	4		53.8	38.5	7.7		1.4	21.1	77.5		12.2	7.3	80.5		
PHF	.852	.786	.500	.871	.438	.625	.250	.542	.250	.536	.809	.845	.500	.375	.750	.707	.856

Traffic Data Service

Campbell, CA
 (408) 377-2988
tdsbay@cs.com

File Name : 80AM FINAL
 Site Code : 00000080
 Start Date : 6/6/2013
 Page No : 2

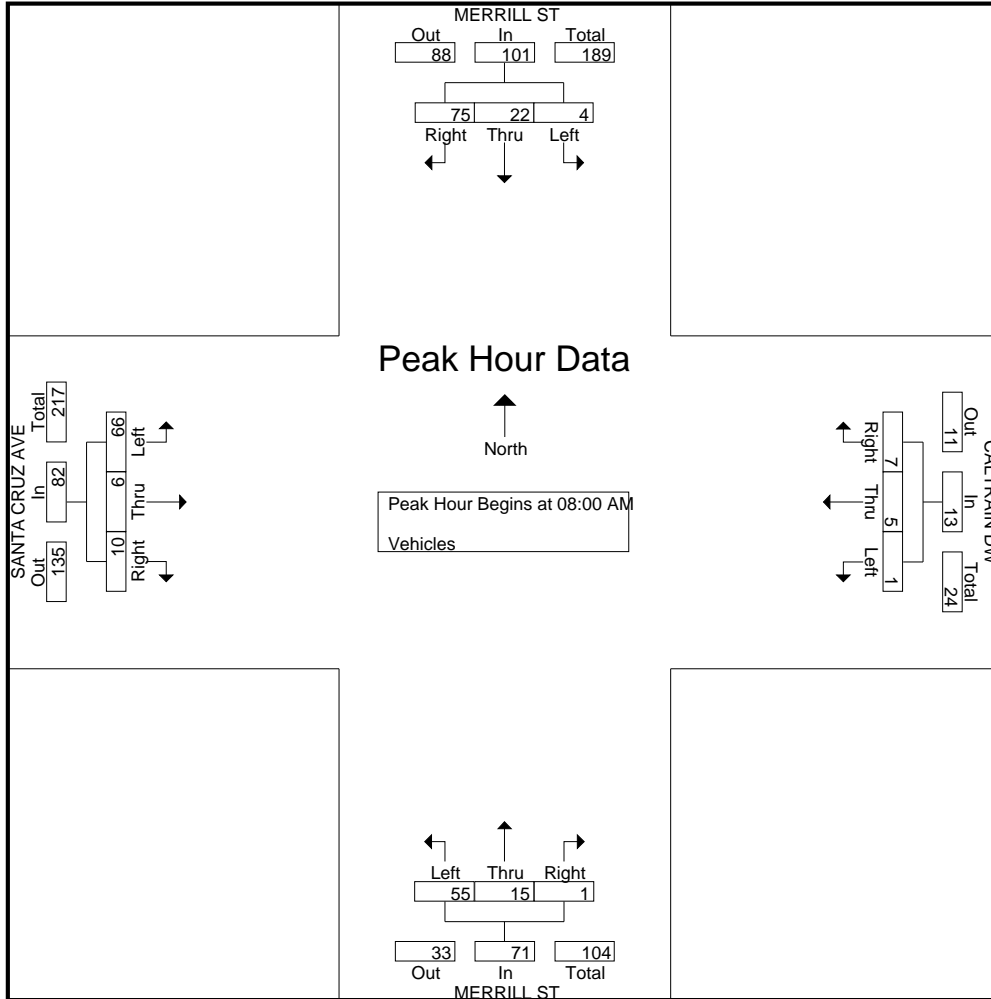

Traffic Data Service

Campbell, CA
 (408) 377-2988
 tdsbay@cs.com

File Name : 80AM FINAL
 Site Code : 00000080
 Start Date : 6/6/2013
 Page No : 1

Groups Printed- Bikes

Start Time	MERRILL ST Southbound					CALTRAIN DW Westbound					MERRILL ST Northbound					SANTA CRUZ AVE Eastbound					Int. Total
	Right	Thru	Left	Peds	App. Total	Right	Thru	Left	Peds	App. Total	Right	Thru	Left	Peds	App. Total	Right	Thru	Left	Peds	App. Total	
07:00 AM	0	0	0	0	0	0	0	0	0	0	0	0	0	0	0	0	0	0	0	0	0
07:15 AM	0	0	0	0	0	0	0	0	0	0	0	0	0	0	0	0	0	3	0	3	3
07:30 AM	1	0	0	0	1	0	0	0	0	0	0	0	1	0	1	1	0	2	0	3	5
07:45 AM	4	0	0	0	4	0	0	0	0	0	0	1	2	0	3	1	0	0	0	1	8
Total	5	0	0	0	5	0	0	0	0	0	0	1	3	0	4	2	0	5	0	7	16
08:00 AM	0	0	0	0	0	0	0	0	0	0	0	0	4	0	4	0	0	0	0	0	4
08:15 AM	0	1	0	0	1	0	0	0	0	0	0	0	0	0	0	0	0	3	0	3	4
08:30 AM	2	0	0	0	2	0	0	0	0	0	0	0	0	0	0	0	0	3	0	3	5
08:45 AM	1	0	0	0	1	0	1	0	0	1	0	0	0	0	0	1	1	0	0	2	4
Total	3	1	0	0	4	0	1	0	0	1	0	0	4	0	4	1	1	6	0	8	17
Grand Total	8	1	0	0	9	0	1	0	0	1	0	1	7	0	8	3	1	11	0	15	33
Apprch %	88.9	11.1	0	0		0	100	0	0		0	12.5	87.5	0		20	6.7	73.3	0		
Total %	24.2	3	0	0	27.3	0	3	0	0	3	0	3	21.2	0	24.2	9.1	3	33.3	0	45.5	

Start Time	MERRILL ST Southbound					CALTRAIN DW Westbound					MERRILL ST Northbound					SANTA CRUZ AVE Eastbound					Int. Total
	Right	Thru	Left	Peds	App. Total	Right	Thru	Left	Peds	App. Total	Right	Thru	Left	Peds	App. Total	Right	Thru	Left	Peds	App. Total	
Peak Hour Analysis From 07:00 AM to 08:45 AM - Peak 1 of 1																					
Peak Hour for Entire Intersection Begins at 07:30 AM																					
07:30 AM	1	0	0	0	1	0	0	0	0	0	0	0	1	1	1	1	0	2	0	3	5
07:45 AM	4	0	0	0	4	0	0	0	0	0	0	1	2	3	3	1	0	0	0	1	8
08:00 AM	0	0	0	0	0	0	0	0	0	0	0	0	4	4	4	0	0	0	0	0	4
08:15 AM	0	1	0	0	1	0	0	0	0	0	0	0	0	0	0	0	0	3	0	3	4
Total Volume	5	1	0	0	6	0	0	0	0	0	0	1	7	8	8	2	0	5	0	7	21
% App. Total	83.3	16.7	0	0		0	0	0	0		0	12.5	87.5	0		28.6	0	71.4	0		
PHF	.313	.250	.000	.000	.375	.000	.000	.000	.000	.000	.000	.250	.438	.500	.500	.500	.000	.417	.583	.656	

Traffic Data Service

Campbell, CA
(408) 377-2988
tdsbay@cs.com

File Name : 80AM FINAL
Site Code : 00000080
Start Date : 6/6/2013
Page No : 2

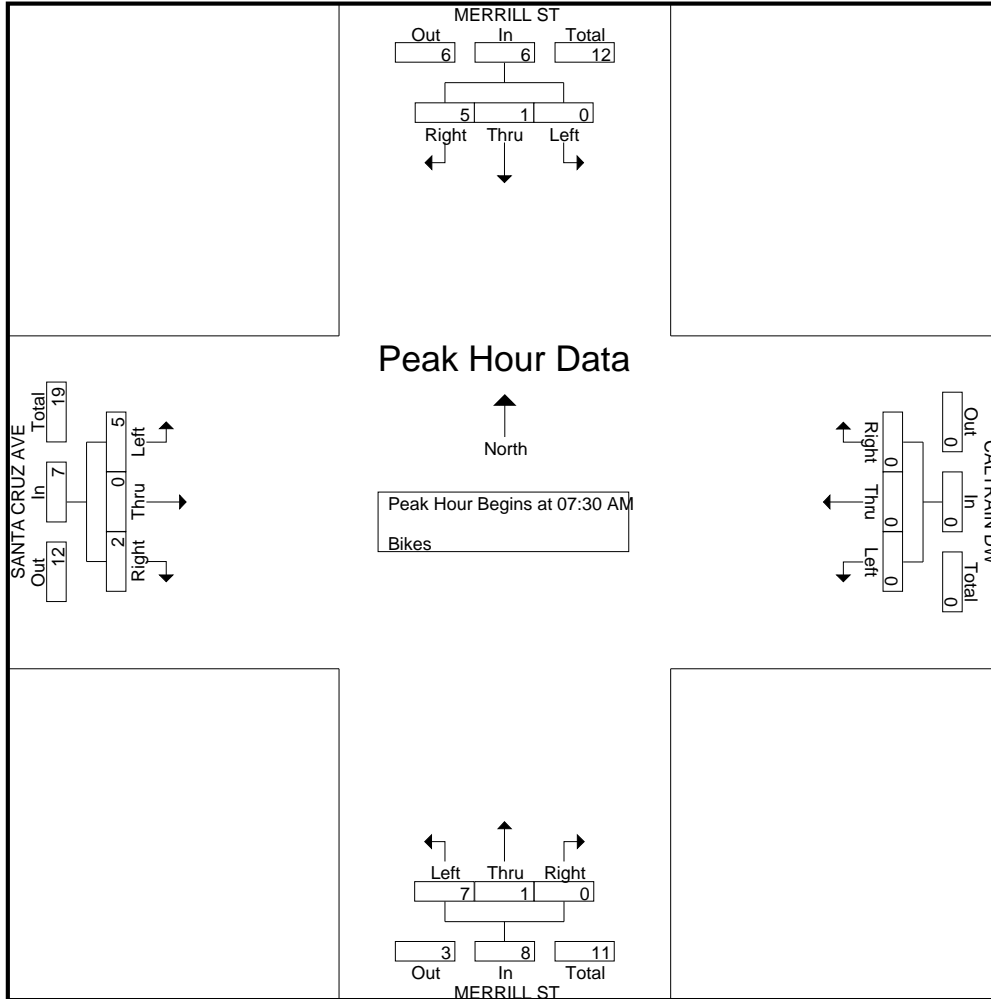

Traffic Data Service

Campbell, CA
 (408) 377-2988
 tdsbay@cs.com

File Name : 80PM FINAL
 Site Code : 00000080
 Start Date : 6/6/2013
 Page No : 1

Groups Printed- Vehicles

Start Time	MERRILL ST Southbound					CALTRAIN DW Westbound					MERRILL ST Northbound					SANTA CRUZ AVE Eastbound					Int. Total
	Right	Thru	Left	Peds	App. Total	Right	Thru	Left	Peds	App. Total	Right	Thru	Left	Peds	App. Total	Right	Thru	Left	Peds	App. Total	
04:00 PM	14	0	1	12	27	0	2	0	3	5	0	1	7	8	16	1	1	23	9	34	82
04:15 PM	18	6	2	7	33	1	1	0	7	9	1	4	6	9	20	3	1	18	6	28	90
04:30 PM	16	2	1	7	26	1	2	0	6	9	0	2	8	5	15	1	0	22	7	30	80
04:45 PM	25	1	0	8	34	0	0	0	3	3	0	1	17	12	30	2	1	19	7	29	96
Total	73	9	4	34	120	2	5	0	19	26	1	8	38	34	81	7	3	82	29	121	348
05:00 PM	27	2	2	7	38	3	2	0	4	9	0	3	11	14	28	3	0	30	7	40	115
05:15 PM	13	1	2	14	30	7	2	1	16	26	0	7	7	18	32	2	0	16	8	26	114
05:30 PM	20	0	0	9	29	2	5	0	10	17	0	2	13	11	26	4	1	23	4	32	104
05:45 PM	11	3	2	8	24	2	1	0	6	9	0	3	7	8	18	1	0	24	2	27	78
Total	71	6	6	38	121	14	10	1	36	61	0	15	38	51	104	10	1	93	21	125	411
Grand Total	144	15	10	72	241	16	15	1	55	87	1	23	76	85	185	17	4	175	50	246	759
Apprch %	59.8	6.2	4.1	29.9		18.4	17.2	1.1	63.2		0.5	12.4	41.1	45.9		6.9	1.6	71.1	20.3		
Total %	19	2	1.3	9.5	31.8	2.1	2	0.1	7.2	11.5	0.1	3	10	11.2	24.4	2.2	0.5	23.1	6.6	32.4	

Start Time	MERRILL ST Southbound					CALTRAIN DW Westbound					MERRILL ST Northbound					SANTA CRUZ AVE Eastbound					Int. Total
	Right	Thru	Left	Peds	App. Total	Right	Thru	Left	Peds	App. Total	Right	Thru	Left	Peds	App. Total	Right	Thru	Left	Peds	App. Total	
04:45 PM	25	1	0		26	0	0	0	0	0	0	1	17	18		2	1	19		22	66
05:00 PM	27	2	2		31	3	2	0		5	0	3	11	14		3	0	30		33	83
05:15 PM	13	1	2		16	7	2	1		10	0	7	7	14		2	0	16		18	58
05:30 PM	20	0	0		20	2	5	0		7	0	2	13	15		4	1	23		28	70
Total Volume	85	4	4		93	12	9	1		22	0	13	48	61		11	2	88		101	277
% App. Total	91.4	4.3	4.3			54.5	40.9	4.5			0	21.3	78.7			10.9	2	87.1			
PHF	.787	.500	.500		.750	.429	.450	.250		.550	.000	.464	.706	.847		.688	.500	.733		.765	.834

Peak Hour Analysis From 04:00 PM to 05:45 PM - Peak 1 of 1

Peak Hour for Entire Intersection Begins at 04:45 PM

Traffic Data Service

Campbell, CA

(408) 377-2988

tdsbay@cs.com

File Name : 80PM FINAL

Site Code : 00000080

Start Date : 6/6/2013

Page No : 2

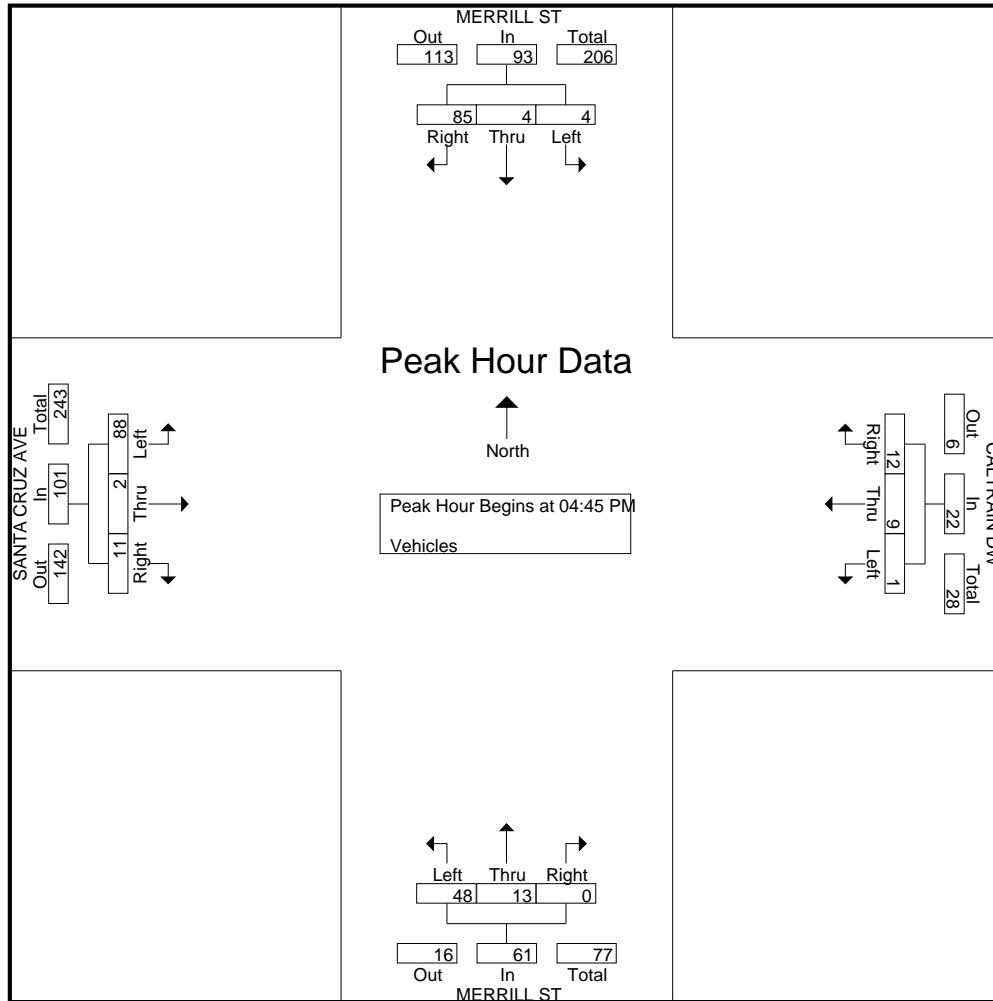

Traffic Data Service

Campbell, CA
 (408) 377-2988
 tdsbay@cs.com

File Name : 80PM FINAL
 Site Code : 00000080
 Start Date : 6/6/2013
 Page No : 1

Groups Printed- Bikes

Start Time	MERRILL ST Southbound					CALTRAIN DW Westbound					MERRILL ST Northbound					SANTA CRUZ AVE Eastbound					Int. Total	
	Right	Thru	Left	Peds	App. Total	Right	Thru	Left	Peds	App. Total	Right	Thru	Left	Peds	App. Total	Right	Thru	Left	Peds	App. Total		
04:00 PM	1	0	0	0	1	0	0	0	0	0	0	0	1	0	1	0	0	0	0	0	0	2
04:15 PM	3	0	0	0	3	0	2	0	0	2	0	0	0	0	0	0	0	0	0	0	0	5
04:30 PM	0	0	0	0	0	0	0	0	0	0	0	1	1	0	2	2	0	1	0	3	0	5
04:45 PM	1	0	0	0	1	0	0	0	0	0	0	0	0	0	0	1	0	4	0	5	0	6
Total	5	0	0	0	5	0	2	0	0	2	0	1	2	0	3	3	0	5	0	8	18	
05:00 PM	1	0	0	0	1	0	0	0	0	0	0	1	1	0	2	0	0	1	0	1	0	4
05:15 PM	1	0	0	0	1	0	0	0	0	0	0	1	1	0	2	0	0	1	0	1	0	4
05:30 PM	7	0	0	0	7	0	2	0	0	2	0	0	2	0	2	0	1	2	0	3	0	14
05:45 PM	0	0	0	0	0	0	0	0	0	0	0	0	1	0	1	0	0	0	0	0	0	1
Total	9	0	0	0	9	0	2	0	0	2	0	2	5	0	7	0	1	4	0	5	23	
Grand Total	14	0	0	0	14	0	4	0	0	4	0	3	7	0	10	3	1	9	0	13	0	41
Apprch %	100	0	0	0		0	100	0	0		0	30	70	0		23.1	7.7	69.2	0			
Total %	34.1	0	0	0	34.1	0	9.8	0	0	9.8	0	7.3	17.1	0	24.4	7.3	2.4	22	0	31.7		

Start Time	MERRILL ST Southbound				CALTRAIN DW Westbound				MERRILL ST Northbound				SANTA CRUZ AVE Eastbound				Int. Total
	Right	Thru	Left	App. Total	Right	Thru	Left	App. Total	Right	Thru	Left	App. Total	Right	Thru	Left	App. Total	
04:45 PM	1	0	0	1	0	0	0	0	0	0	0	0	1	0	4	5	6
05:00 PM	1	0	0	1	0	0	0	0	0	1	1	2	0	0	1	1	4
05:15 PM	1	0	0	1	0	0	0	0	0	1	1	2	0	0	1	1	4
05:30 PM	7	0	0	7	0	2	0	2	0	0	2	2	0	1	2	3	14
Total Volume	10	0	0	10	0	2	0	2	0	2	4	6	1	1	8	10	28
% App. Total	100	0	0		0	100	0		0	33.3	66.7		10	10	80		
PHF	.357	.000	.000	.357	.000	.250	.000	.250	.000	.500	.500	.750	.250	.250	.500	.500	.500

Peak Hour Analysis From 04:00 PM to 05:45 PM - Peak 1 of 1

Peak Hour for Entire Intersection Begins at 04:45 PM

Traffic Data Service

Campbell, CA
(408) 377-2988
tdsbay@cs.com

File Name : 80PM FINAL
Site Code : 00000080
Start Date : 6/6/2013
Page No : 2

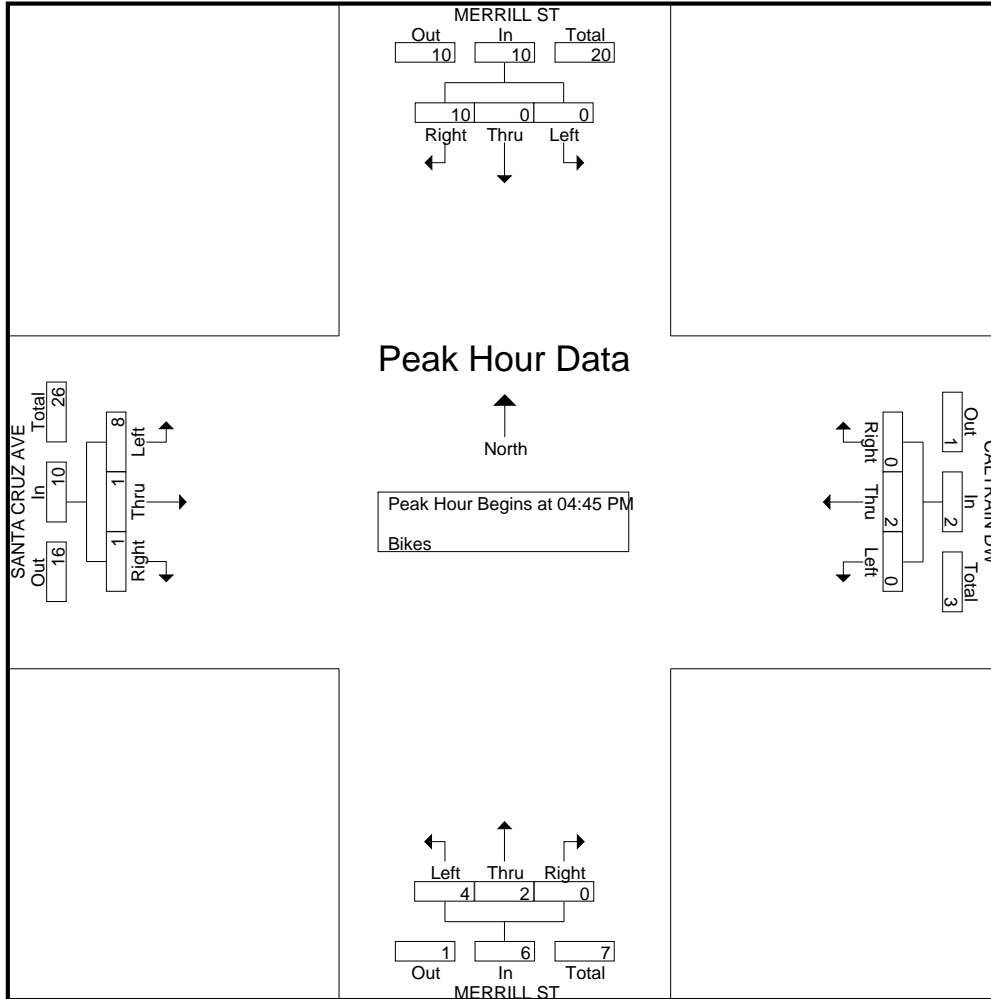

Traffic Data Service

Campbell, CA
 (408) 377-2988
 tdsbay@cs.com

File Name : 22AM FINAL
 Site Code : 00000022
 Start Date : 5/30/2013
 Page No : 1

Groups Printed- Vehicles

Start Time	ALMA ST Southbound					RAVENSWOOD AVE Westbound					ALMA ST Northbound					RAVENSWOOD AVE Eastbound					Int. Total
	Right	Thru	Left	Peds	App. Total	Right	Thru	Left	Peds	App. Total	Right	Thru	Left	Peds	App. Total	Right	Thru	Left	Peds	App. Total	
07:00 AM	8	2	1	1	12	6	100	2	3	111	0	0	4	1	5	15	66	1	2	84	212
07:15 AM	9	2	0	15	26	12	143	0	12	167	2	0	3	2	7	24	89	3	0	116	316
07:30 AM	13	0	2	13	28	16	187	1	12	216	5	1	5	2	13	31	138	6	0	175	432
07:45 AM	7	2	0	11	20	3	192	0	26	221	2	2	2	5	11	48	160	4	1	213	465
Total	37	6	3	40	86	37	622	3	53	715	9	3	14	10	36	118	453	14	3	588	1425
08:00 AM	8	1	0	20	29	9	221	0	14	244	1	1	6	7	15	55	182	3	1	241	529
08:15 AM	8	3	0	18	29	7	155	0	11	173	0	1	1	9	11	56	162	4	0	222	435
08:30 AM	11	0	1	17	29	6	198	2	16	222	1	1	3	2	7	48	159	5	1	213	471
08:45 AM	5	0	1	22	28	7	187	1	24	219	1	0	7	1	9	44	174	8	0	226	482
Total	32	4	2	77	115	29	761	3	65	858	3	3	17	19	42	203	677	20	2	902	1917
Grand Total	69	10	5	117	201	66	1383	6	118	1573	12	6	31	29	78	321	1130	34	5	1490	3342
Apprch %	34.3	5	2.5	58.2		4.2	87.9	0.4	7.5		15.4	7.7	39.7	37.2		21.5	75.8	2.3	0.3		
Total %	2.1	0.3	0.1	3.5	6	2	41.4	0.2	3.5	47.1	0.4	0.2	0.9	0.9	2.3	9.6	33.8	1	0.1	44.6	

Start Time	ALMA ST Southbound				RAVENSWOOD AVE Westbound				ALMA ST Northbound				RAVENSWOOD AVE Eastbound				Int. Total
	Right	Thru	Left	App. Total	Right	Thru	Left	App. Total	Right	Thru	Left	App. Total	Right	Thru	Left	App. Total	
Peak Hour Analysis From 07:00 AM to 08:45 AM - Peak 1 of 1																	
Peak Hour for Entire Intersection Begins at 08:00 AM																	
08:00 AM	8	1	0	9	9	221	0	230	1	1	6	8	55	182	3	240	487
08:15 AM	8	3	0	11	7	155	0	162	0	1	1	2	56	162	4	222	397
08:30 AM	11	0	1	12	6	198	2	206	1	1	3	5	48	159	5	212	435
08:45 AM	5	0	1	6	7	187	1	195	1	0	7	8	44	174	8	226	435
Total Volume	32	4	2	38	29	761	3	793	3	3	17	23	203	677	20	900	1754
% App. Total	84.2	10.5	5.3		3.7	96	0.4		13	13	73.9		22.6	75.2	2.2		
PHF	.727	.333	.500	.792	.806	.861	.375	.862	.750	.750	.607	.719	.906	.930	.625	.938	.900

Traffic Data Service

Campbell, CA
 (408) 377-2988
tdsbay@cs.com

File Name : 22AM FINAL
 Site Code : 00000022
 Start Date : 5/30/2013
 Page No : 2

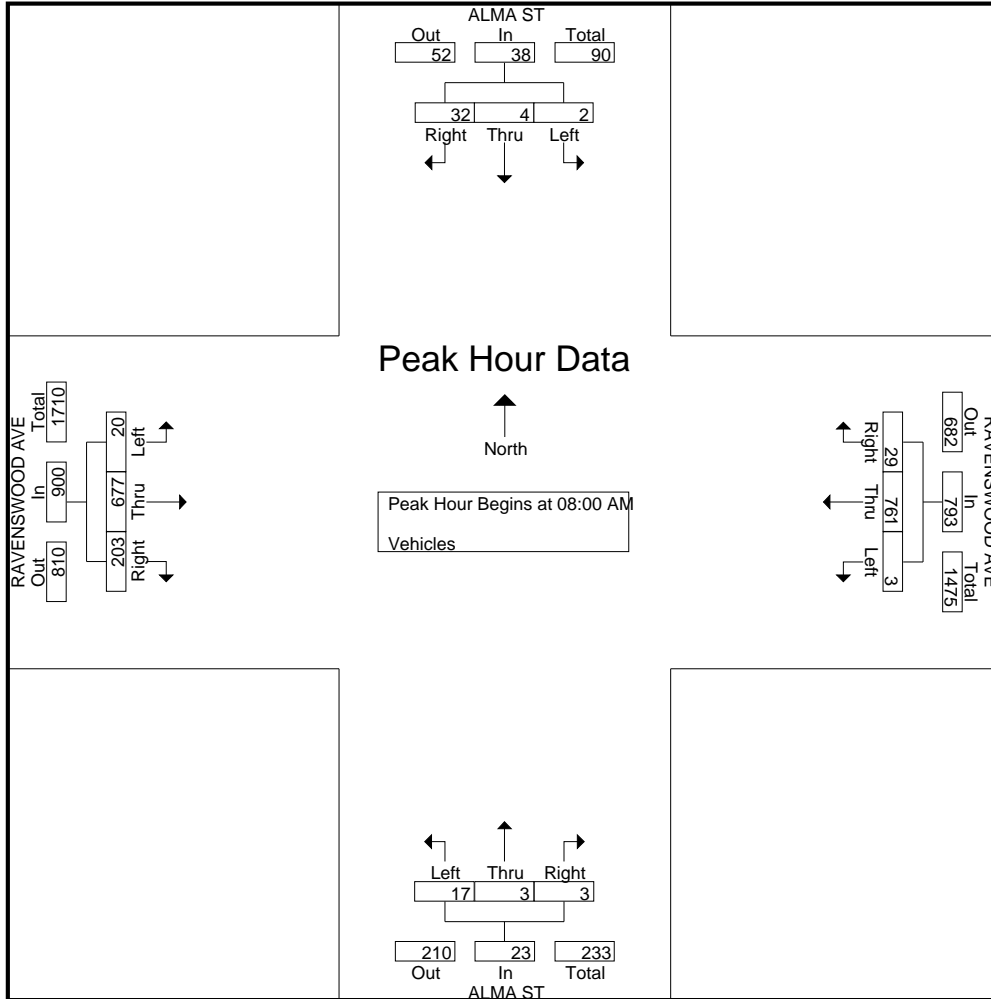

Traffic Data Service

Campbell, CA
 (408) 377-2988
 tdsbay@cs.com

File Name : 22AM FINAL
 Site Code : 00000022
 Start Date : 5/30/2013
 Page No : 1

Groups Printed- Bikes

Start Time	ALMA ST Southbound					RAVENSWOOD AVE Westbound					ALMA ST Northbound					RAVENSWOOD AVE Eastbound					Int. Total
	Right	Thru	Left	Peds	App. Total	Right	Thru	Left	Peds	App. Total	Right	Thru	Left	Peds	App. Total	Right	Thru	Left	Peds	App. Total	
07:00 AM	0	0	0	0	0	0	1	0	0	1	0	1	1	0	2	0	1	0	0	1	4
07:15 AM	0	1	0	0	1	0	1	0	0	1	0	1	1	0	2	0	2	0	0	2	6
07:30 AM	1	3	2	0	6	1	1	0	0	2	0	0	1	0	1	2	8	0	0	10	19
07:45 AM	0	1	1	0	2	0	7	0	0	7	0	1	0	0	1	0	2	0	0	2	12
Total	1	5	3	0	9	1	10	0	0	11	0	3	3	0	6	2	13	0	0	15	41
08:00 AM	0	0	0	0	0	0	4	0	0	4	1	0	0	0	1	1	3	0	0	4	9
08:15 AM	0	0	0	0	0	0	3	0	0	3	1	2	1	0	4	2	1	0	0	3	10
08:30 AM	0	1	1	0	2	1	4	0	0	5	0	2	0	0	2	2	1	0	0	3	12
08:45 AM	0	0	1	0	1	0	1	0	0	1	0	0	3	0	3	4	4	0	0	8	13
Total	0	1	2	0	3	1	12	0	0	13	2	4	4	0	10	9	9	0	0	18	44
Grand Total	1	6	5	0	12	2	22	0	0	24	2	7	7	0	16	11	22	0	0	33	85
Apprch %	8.3	50	41.7	0		8.3	91.7	0	0		12.5	43.8	43.8	0		33.3	66.7	0	0		
Total %	1.2	7.1	5.9	0	14.1	2.4	25.9	0	0	28.2	2.4	8.2	8.2	0	18.8	12.9	25.9	0	0	38.8	

Start Time	ALMA ST Southbound				RAVENSWOOD AVE Westbound				ALMA ST Northbound				RAVENSWOOD AVE Eastbound				Int. Total
	Right	Thru	Left	App. Total	Right	Thru	Left	App. Total	Right	Thru	Left	App. Total	Right	Thru	Left	App. Total	
07:30 AM	1	3	2	6	1	1	0	2	0	0	1	1	2	8	0	10	19
07:45 AM	0	1	1	2	0	7	0	7	0	1	0	1	0	2	0	2	12
08:00 AM	0	0	0	0	0	4	0	4	1	0	0	1	1	3	0	4	9
08:15 AM	0	0	0	0	0	3	0	3	1	2	1	4	2	1	0	3	10
Total Volume	1	4	3	8	1	15	0	16	2	3	2	7	5	14	0	19	50
% App. Total	12.5	50	37.5		6.2	93.8	0		28.6	42.9	28.6		26.3	73.7	0		
PHF	.250	.333	.375	.333	.250	.536	.000	.571	.500	.375	.500	.438	.625	.438	.000	.475	.658

Peak Hour Analysis From 07:00 AM to 08:45 AM - Peak 1 of 1

Peak Hour for Entire Intersection Begins at 07:30 AM

Traffic Data Service

Campbell, CA
(408) 377-2988
tdsbay@cs.com

File Name : 22AM FINAL
Site Code : 00000022
Start Date : 5/30/2013
Page No : 2

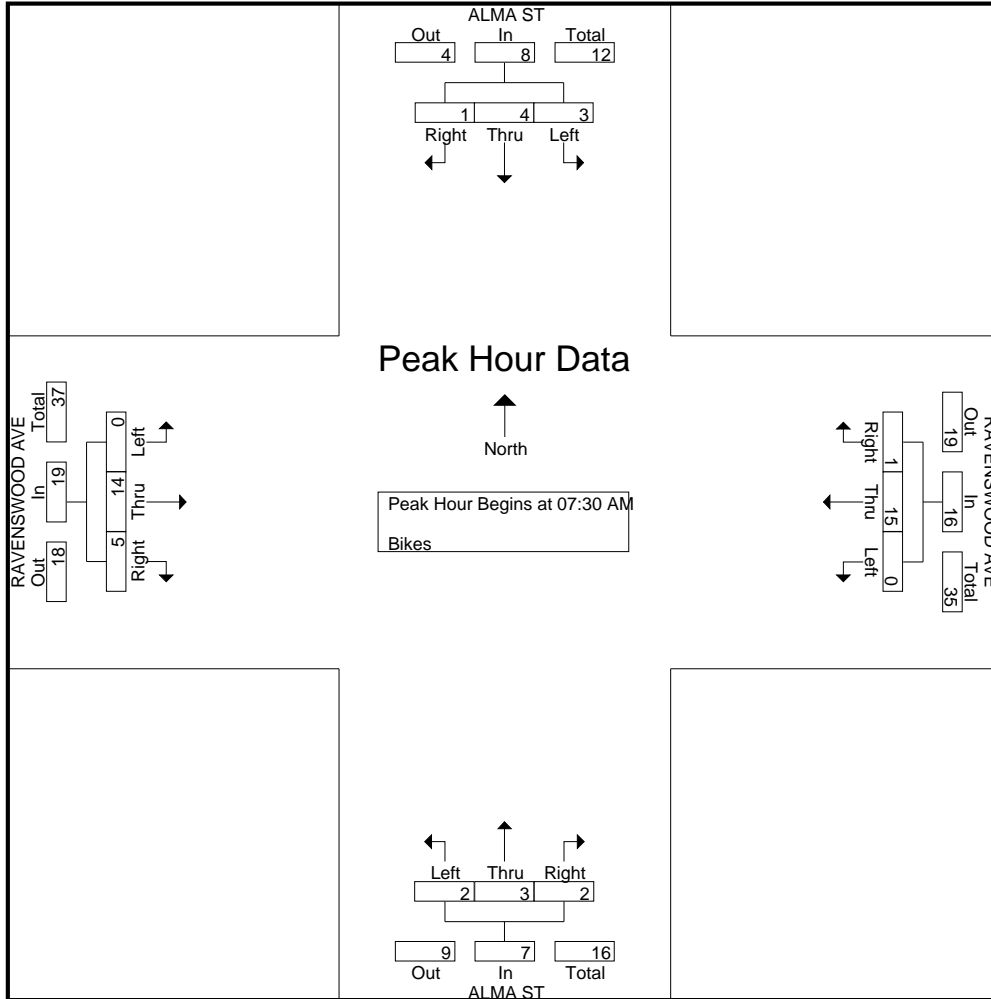

Traffic Data Service

Campbell, CA
 (408) 377-2988
 tdsbay@cs.com

File Name : 22PM FINAL
 Site Code : 00000022
 Start Date : 5/30/2013
 Page No : 1

Groups Printed- Vehicles

Start Time	ALMA ST Southbound					RAVENSWOOD AVE Westbound					ALMA ST Northbound					RAVENSWOOD AVE Eastbound					Int. Total
	Right	Thru	Left	Peds	App. Total	Right	Thru	Left	Peds	App. Total	Right	Thru	Left	Peds	App. Total	Right	Thru	Left	Peds	App. Total	
04:00 PM	8	1	1	12	22	6	194	5	17	222	13	4	7	11	35	59	181	1	0	241	520
04:15 PM	5	1	0	19	25	9	170	1	31	211	14	2	4	7	27	63	193	0	0	256	519
04:30 PM	11	1	0	24	36	10	130	2	27	169	15	3	16	4	38	70	161	3	1	235	478
04:45 PM	4	0	0	19	23	2	166	2	19	189	27	1	4	10	42	83	187	2	0	272	526
Total	28	3	1	74	106	27	660	10	94	791	69	10	31	32	142	275	722	6	1	1004	2043
05:00 PM	19	1	0	28	48	5	185	8	20	218	13	5	10	6	34	83	213	3	1	300	600
05:15 PM	14	1	2	49	66	10	184	3	30	227	20	1	8	3	32	67	211	3	1	282	607
05:30 PM	10	2	0	23	35	9	159	5	24	197	12	0	3	9	24	79	201	5	2	287	543
05:45 PM	7	2	0	14	23	5	162	2	18	187	8	5	4	13	30	61	180	4	1	246	486
Total	50	6	2	114	172	29	690	18	92	829	53	11	25	31	120	290	805	15	5	1115	2236
Grand Total	78	9	3	188	278	56	1350	28	186	1620	122	21	56	63	262	565	1527	21	6	2119	4279
Apprch %	28.1	3.2	1.1	67.6		3.5	83.3	1.7	11.5		46.6	8	21.4	24		26.7	72.1	1	0.3		
Total %	1.8	0.2	0.1	4.4	6.5	1.3	31.5	0.7	4.3	37.9	2.9	0.5	1.3	1.5	6.1	13.2	35.7	0.5	0.1	49.5	

Start Time	ALMA ST Southbound				RAVENSWOOD AVE Westbound				ALMA ST Northbound				RAVENSWOOD AVE Eastbound				Int. Total
	Right	Thru	Left	App. Total	Right	Thru	Left	App. Total	Right	Thru	Left	App. Total	Right	Thru	Left	App. Total	
Peak Hour Analysis From 04:00 PM to 05:45 PM - Peak 1 of 1																	
Peak Hour for Entire Intersection Begins at 04:45 PM																	
04:45 PM	4	0	0	4	2	166	2	170	27	1	4	32	83	187	2	272	478
05:00 PM	19	1	0	20	5	185	8	198	13	5	10	28	83	213	3	299	545
05:15 PM	14	1	2	17	10	184	3	197	20	1	8	29	67	211	3	281	524
05:30 PM	10	2	0	12	9	159	5	173	12	0	3	15	79	201	5	285	485
Total Volume	47	4	2	53	26	694	18	738	72	7	25	104	312	812	13	1137	2032
% App. Total	88.7	7.5	3.8		3.5	94	2.4		69.2	6.7	24		27.4	71.4	1.1		
PHF	.618	.500	.250	.663	.650	.938	.563	.932	.667	.350	.625	.813	.940	.953	.650	.951	.932

Traffic Data Service

Campbell, CA
 (408) 377-2988
 tdsbay@cs.com

File Name : 22PM FINAL
 Site Code : 00000022
 Start Date : 5/30/2013
 Page No : 2

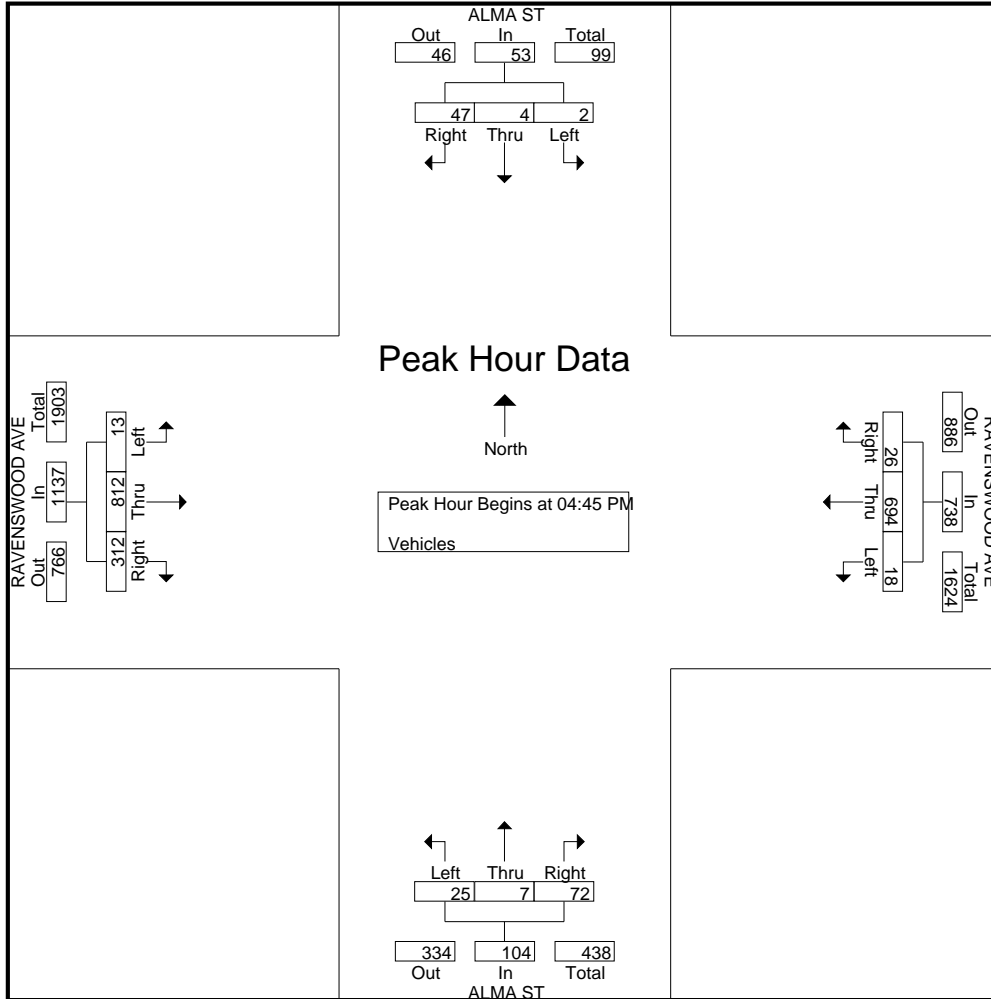

Traffic Data Service

Campbell, CA
 (408) 377-2988
 tdsbay@cs.com

File Name : 22PM FINAL
 Site Code : 00000022
 Start Date : 5/30/2013
 Page No : 1

Groups Printed- Bikes

Start Time	ALMA ST Southbound					RAVENSWOOD AVE Westbound					ALMA ST Northbound					RAVENSWOOD AVE Eastbound					Int. Total
	Right	Thru	Left	Peds	App. Total	Right	Thru	Left	Peds	App. Total	Right	Thru	Left	Peds	App. Total	Right	Thru	Left	Peds	App. Total	
04:00 PM	0	0	0	0	0	2	2	0	0	4	0	1	1	0	2	0	0	0	0	0	6
04:15 PM	0	0	0	0	0	0	0	0	0	0	0	1	0	0	1	0	3	0	0	3	4
04:30 PM	0	0	0	0	0	3	0	0	0	3	1	1	0	0	2	1	2	0	0	3	8
04:45 PM	0	0	0	0	0	2	1	0	0	3	0	0	0	0	0	1	0	0	0	1	4
Total	0	0	0	0	0	7	3	0	0	10	1	3	1	0	5	2	5	0	0	7	22
05:00 PM	0	0	0	0	0	0	0	0	0	0	0	3	2	0	5	3	1	0	0	4	9
05:15 PM	0	0	0	0	0	0	3	0	0	3	1	1	1	0	3	2	3	0	0	5	11
05:30 PM	0	2	1	0	3	1	0	0	0	1	0	0	0	0	0	1	1	1	0	3	7
05:45 PM	0	0	0	0	0	1	0	0	0	1	0	1	1	0	2	1	0	0	0	1	4
Total	0	2	1	0	3	2	3	0	0	5	1	5	4	0	10	7	5	1	0	13	31
Grand Total	0	2	1	0	3	9	6	0	0	15	2	8	5	0	15	9	10	1	0	20	53
Apprch %	0	66.7	33.3	0		60	40	0	0		13.3	53.3	33.3	0		45	50	5	0		
Total %	0	3.8	1.9	0	5.7	17	11.3	0	0	28.3	3.8	15.1	9.4	0	28.3	17	18.9	1.9	0	37.7	

Start Time	ALMA ST Southbound				RAVENSWOOD AVE Westbound				ALMA ST Northbound				RAVENSWOOD AVE Eastbound				Int. Total
	Right	Thru	Left	App. Total	Right	Thru	Left	App. Total	Right	Thru	Left	App. Total	Right	Thru	Left	App. Total	
Peak Hour Analysis From 04:00 PM to 05:45 PM - Peak 1 of 1																	
Peak Hour for Entire Intersection Begins at 04:30 PM																	
04:30 PM	0	0	0	0	3	0	0	3	1	1	0	2	1	2	0	3	8
04:45 PM	0	0	0	0	2	1	0	3	0	0	0	0	1	0	0	1	4
05:00 PM	0	0	0	0	0	0	0	0	0	3	2	5	3	1	0	4	9
05:15 PM	0	0	0	0	0	3	0	3	1	1	1	3	2	3	0	5	11
Total Volume	0	0	0	0	5	4	0	9	2	5	3	10	7	6	0	13	32
% App. Total	0	0	0		55.6	44.4	0		20	50	30		53.8	46.2	0		
PHF	.000	.000	.000	.000	.417	.333	.000	.750	.500	.417	.375	.500	.583	.500	.000	.650	.727

Traffic Data Service

Campbell, CA
 (408) 377-2988
 tdsbay@cs.com

File Name : 22PM FINAL
 Site Code : 00000022
 Start Date : 5/30/2013
 Page No : 2

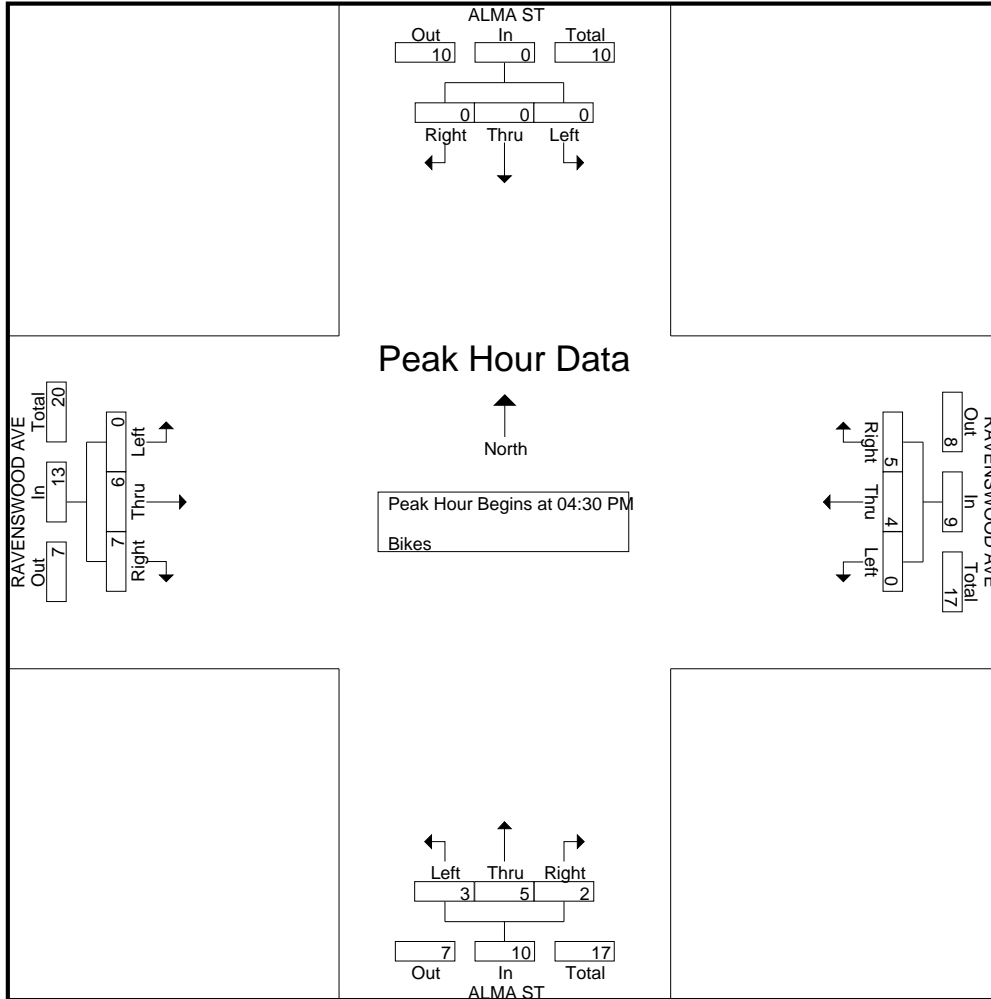

Traffic Data Service

Campbell, CA
 (408) 377-2988
 tdsbay@cs.com

File Name : 82AM FINAL
 Site Code : 00000082
 Start Date : 6/4/2013
 Page No : 1

Groups Printed- Vehicles

Start Time	EL CAMINO REAL Southbound					RAVENSWOOD AVE Westbound					EL CAMINO REAL Northbound					MENLO AVE Eastbound					Int. Total
	Right	Thru	Left	Peds	App. Total	Right	Thru	Left	Peds	App. Total	Right	Thru	Left	Peds	App. Total	Right	Thru	Left	Peds	App. Total	
07:00 AM	2	165	25	1	193	8	38	72	0	118	55	73	11	0	139	3	28	2	3	36	486
07:15 AM	3	232	31	6	272	9	34	88	2	133	66	132	10	0	208	4	41	3	2	50	663
07:30 AM	3	291	32	11	337	13	53	96	1	163	79	162	11	0	252	9	53	2	5	69	821
07:45 AM	2	320	41	7	370	9	61	123	0	193	103	161	19	0	283	11	80	2	9	102	948
Total	10	1008	129	25	1172	39	186	379	3	607	303	528	51	0	882	27	202	9	19	257	2918
08:00 AM	8	313	53	0	374	18	70	112	4	204	116	162	12	0	290	12	77	4	9	102	970
08:15 AM	6	340	38	0	384	14	57	119	1	191	109	167	24	0	300	11	79	3	6	99	974
08:30 AM	2	339	56	0	397	16	46	122	5	189	91	160	21	0	272	14	85	4	2	105	963
08:45 AM	5	334	43	0	382	12	42	105	3	162	110	173	24	0	307	12	85	3	3	103	954
Total	21	1326	190	0	1537	60	215	458	13	746	426	662	81	0	1169	49	326	14	20	409	3861
Grand Total	31	2334	319	25	2709	99	401	837	16	1353	729	1190	132	0	2051	76	528	23	39	666	6779
Apprch %	1.1	86.2	11.8	0.9		7.3	29.6	61.9	1.2		35.5	58	6.4	0		11.4	79.3	3.5	5.9		
Total %	0.5	34.4	4.7	0.4	40	1.5	5.9	12.3	0.2	20	10.8	17.6	1.9	0	30.3	1.1	7.8	0.3	0.6	9.8	

Start Time	EL CAMINO REAL Southbound				RAVENSWOOD AVE Westbound				EL CAMINO REAL Northbound				MENLO AVE Eastbound				Int. Total
	Right	Thru	Left	App. Total	Right	Thru	Left	App. Total	Right	Thru	Left	App. Total	Right	Thru	Left	App. Total	
Peak Hour Analysis From 07:00 AM to 08:45 AM - Peak 1 of 1																	
Peak Hour for Entire Intersection Begins at 08:00 AM																	
08:00 AM	8	313	53	374	18	70	112	200	116	162	12	290	12	77	4	93	957
08:15 AM	6	340	38	384	14	57	119	190	109	167	24	300	11	79	3	93	967
08:30 AM	2	339	56	397	16	46	122	184	91	160	21	272	14	85	4	103	956
08:45 AM	5	334	43	382	12	42	105	159	110	173	24	307	12	85	3	100	948
Total Volume	21	1326	190	1537	60	215	458	733	426	662	81	1169	49	326	14	389	3828
% App. Total	1.4	86.3	12.4		8.2	29.3	62.5		36.4	56.6	6.9		12.6	83.8	3.6		
PHF	.656	.975	.848	.968	.833	.768	.939	.916	.918	.957	.844	.952	.875	.959	.875	.944	.990

Traffic Data Service

Campbell, CA
 (408) 377-2988
 tdsbay@cs.com

File Name : 82AM FINAL
 Site Code : 00000082
 Start Date : 6/4/2013
 Page No : 2

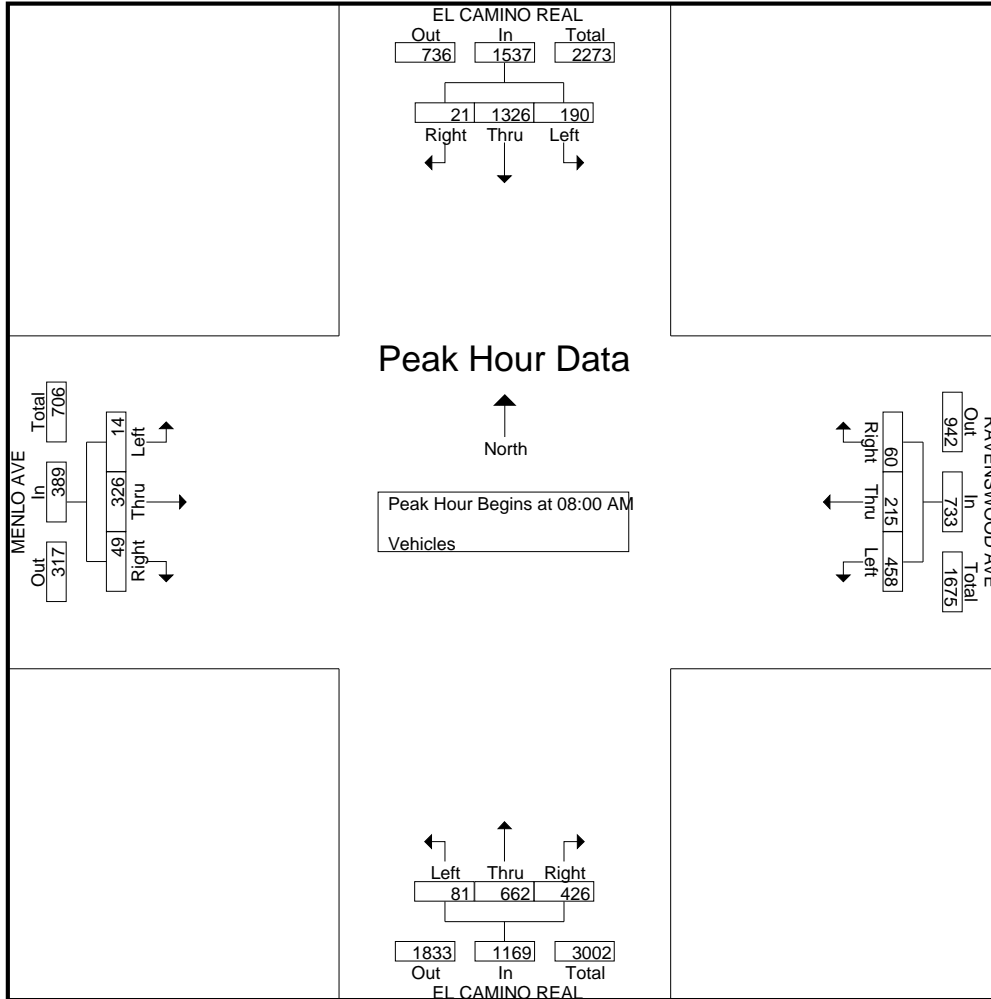

Traffic Data Service

Campbell, CA
(408) 377-2988
tdsbay@cs.com

File Name : 82AM FINAL
Site Code : 00000082
Start Date : 6/4/2013
Page No : 1

Groups Printed- Bikes

Start Time	EL CAMINO REAL Southbound					RAVENSWOOD AVE Westbound					EL CAMINO REAL Northbound					MENLO AVE Eastbound					Int. Total
	Right	Thru	Left	Peds	App. Total	Right	Thru	Left	Peds	App. Total	Right	Thru	Left	Peds	App. Total	Right	Thru	Left	Peds	App. Total	
07:00 AM	0	0	0	0	0	0	0	0	0	0	0	0	0	0	0	0	0	0	0	0	0
07:15 AM	0	1	0	0	1	0	1	0	0	1	0	1	0	0	1	0	2	0	0	2	5
07:30 AM	0	0	0	0	0	0	2	1	0	3	0	0	0	0	0	0	5	0	0	5	8
07:45 AM	0	2	0	0	2	0	7	0	0	7	0	1	0	0	1	0	3	0	0	3	13
Total	0	3	0	0	3	0	10	1	0	11	0	2	0	0	2	0	10	0	0	10	26
08:00 AM	0	2	0	0	2	0	7	0	0	7	0	1	0	0	1	0	10	0	0	10	20
08:15 AM	0	2	0	0	2	0	3	0	0	3	0	1	0	0	1	0	7	0	0	7	13
08:30 AM	0	1	0	0	1	0	1	2	0	3	0	0	0	0	0	0	5	1	0	6	10
08:45 AM	0	2	0	0	2	0	4	1	0	5	0	0	0	0	0	0	2	0	0	2	9
Total	0	7	0	0	7	0	15	3	0	18	0	2	0	0	2	0	24	1	0	25	52
Grand Total	0	10	0	0	10	0	25	4	0	29	0	4	0	0	4	0	34	1	0	35	78
Apprch %	0	100	0	0		0	86.2	13.8	0		0	100	0	0		0	97.1	2.9	0		
Total %	0	12.8	0	0	12.8	0	32.1	5.1	0	37.2	0	5.1	0	0	5.1	0	43.6	1.3	0	44.9	

Start Time	EL CAMINO REAL Southbound				RAVENSWOOD AVE Westbound				EL CAMINO REAL Northbound				MENLO AVE Eastbound				Int. Total
	Right	Thru	Left	App. Total	Right	Thru	Left	App. Total	Right	Thru	Left	App. Total	Right	Thru	Left	App. Total	
Peak Hour Analysis From 07:00 AM to 08:45 AM - Peak 1 of 1																	
Peak Hour for Entire Intersection Begins at 07:45 AM																	
07:45 AM	0	2	0	2	0	7	0	7	0	1	0	1	0	3	0	3	13
08:00 AM	0	2	0	2	0	7	0	7	0	1	0	1	0	10	0	10	20
08:15 AM	0	2	0	2	0	3	0	3	0	1	0	1	0	7	0	7	13
08:30 AM	0	1	0	1	0	1	2	3	0	0	0	0	0	5	1	6	10
Total Volume	0	7	0	7	0	18	2	20	0	3	0	3	0	25	1	26	56
% App. Total	0	100	0		0	90	10		0	100	0		0	96.2	3.8		
PHF	.000	.875	.000	.875	.000	.643	.250	.714	.000	.750	.000	.750	.000	.625	.250	.650	.700

Traffic Data Service

Campbell, CA
(408) 377-2988
tdsbay@cs.com

File Name : 82AM FINAL
Site Code : 00000082
Start Date : 6/4/2013
Page No : 2

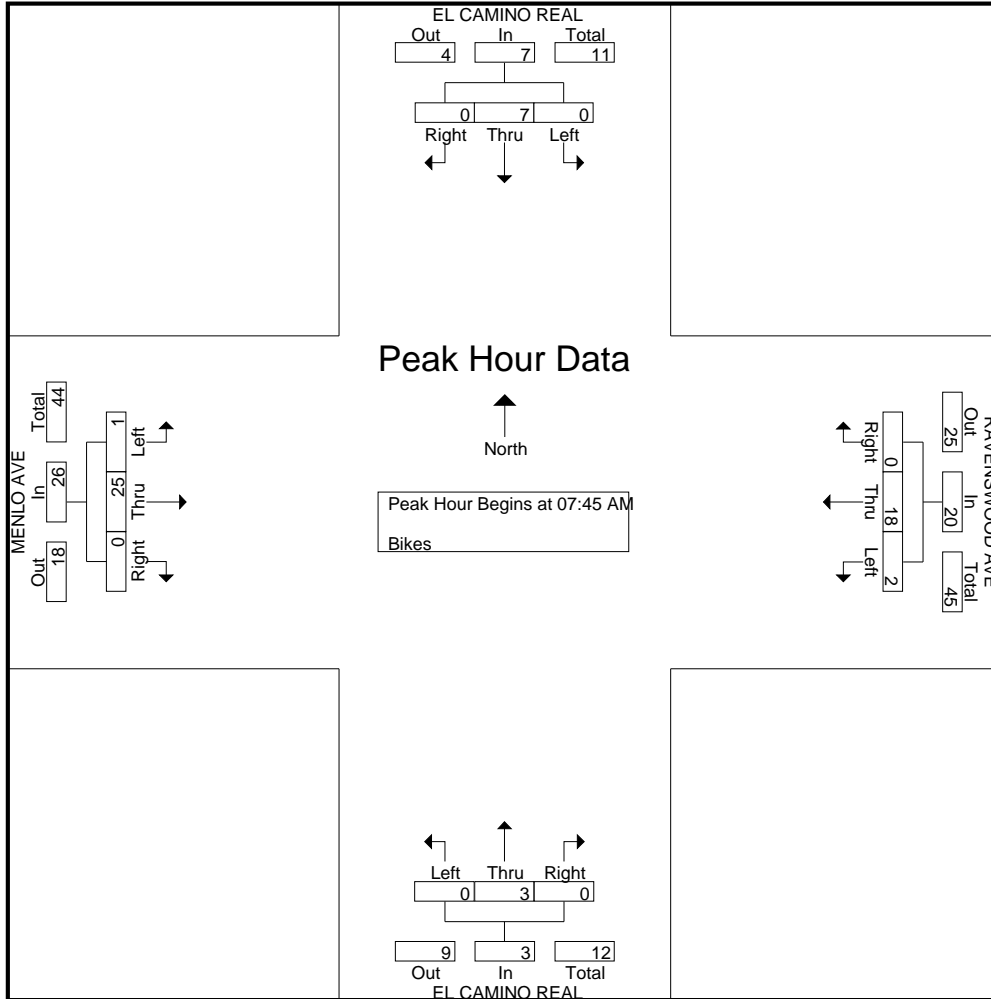

Traffic Data Service

Campbell, CA
 (408) 377-2988
 tdsbay@cs.com

File Name : 82PM FINAL
 Site Code : 00000082
 Start Date : 6/4/2013
 Page No : 1

Groups Printed- Vehicles

Start Time	EL CAMINO REAL Southbound					RAVENSWOOD AVE Westbound					EL CAMINO REAL Northbound					MENLO AVE Eastbound					Int. Total
	Right	Thru	Left	Peds	App. Total	Right	Thru	Left	Peds	App. Total	Right	Thru	Left	Peds	App. Total	Right	Thru	Left	Peds	App. Total	
04:00 PM	15	242	48	12	317	30	57	98	5	190	135	298	41	0	474	21	59	14	11	105	1086
04:15 PM	9	262	36	14	321	14	46	81	6	147	123	342	40	0	505	28	30	5	5	68	1041
04:30 PM	13	235	33	4	285	27	58	92	4	181	136	316	48	0	500	21	82	10	4	117	1083
04:45 PM	13	234	39	13	299	21	58	117	4	200	135	339	36	0	510	27	76	14	4	121	1130
Total	50	973	156	43	1222	92	219	388	19	718	529	1295	165	0	1989	97	247	43	24	411	4340
05:00 PM	11	250	31	18	310	23	61	112	4	200	158	345	33	0	536	29	76	7	9	121	1167
05:15 PM	15	244	48	15	322	15	56	102	7	180	158	353	41	1	553	23	60	12	11	106	1161
05:30 PM	9	268	35	11	323	21	68	110	3	202	159	353	35	0	547	28	51	7	8	94	1166
05:45 PM	7	268	48	8	331	19	64	102	1	186	151	328	40	0	519	25	50	11	1	87	1123
Total	42	1030	162	52	1286	78	249	426	15	768	626	1379	149	1	2155	105	237	37	29	408	4617
Grand Total	92	2003	318	95	2508	170	468	814	34	1486	1155	2674	314	1	4144	202	484	80	53	819	8957
Apprch %	3.7	79.9	12.7	3.8		11.4	31.5	54.8	2.3		27.9	64.5	7.6	0		24.7	59.1	9.8	6.5		
Total %	1	22.4	3.6	1.1	28	1.9	5.2	9.1	0.4	16.6	12.9	29.9	3.5	0	46.3	2.3	5.4	0.9	0.6	9.1	

Start Time	EL CAMINO REAL Southbound				RAVENSWOOD AVE Westbound				EL CAMINO REAL Northbound				MENLO AVE Eastbound				Int. Total
	Right	Thru	Left	App. Total	Right	Thru	Left	App. Total	Right	Thru	Left	App. Total	Right	Thru	Left	App. Total	
Peak Hour Analysis From 04:00 PM to 05:45 PM - Peak 1 of 1																	
Peak Hour for Entire Intersection Begins at 05:00 PM																	
05:00 PM	11	250	31	292	23	61	112	196	158	345	33	536	29	76	7	112	1136
05:15 PM	15	244	48	307	15	56	102	173	158	353	41	552	23	60	12	95	1127
05:30 PM	9	268	35	312	21	68	110	199	159	353	35	547	28	51	7	86	1144
05:45 PM	7	268	48	323	19	64	102	185	151	328	40	519	25	50	11	86	1113
Total Volume	42	1030	162	1234	78	249	426	753	626	1379	149	2154	105	237	37	379	4520
% App. Total	3.4	83.5	13.1		10.4	33.1	56.6		29.1	64	6.9		27.7	62.5	9.8		
PHF	.700	.961	.844	.955	.848	.915	.951	.946	.984	.977	.909	.976	.905	.780	.771	.846	.988

Traffic Data Service

Campbell, CA
 (408) 377-2988
 tdsbay@cs.com

File Name : 82PM FINAL
 Site Code : 00000082
 Start Date : 6/4/2013
 Page No : 2

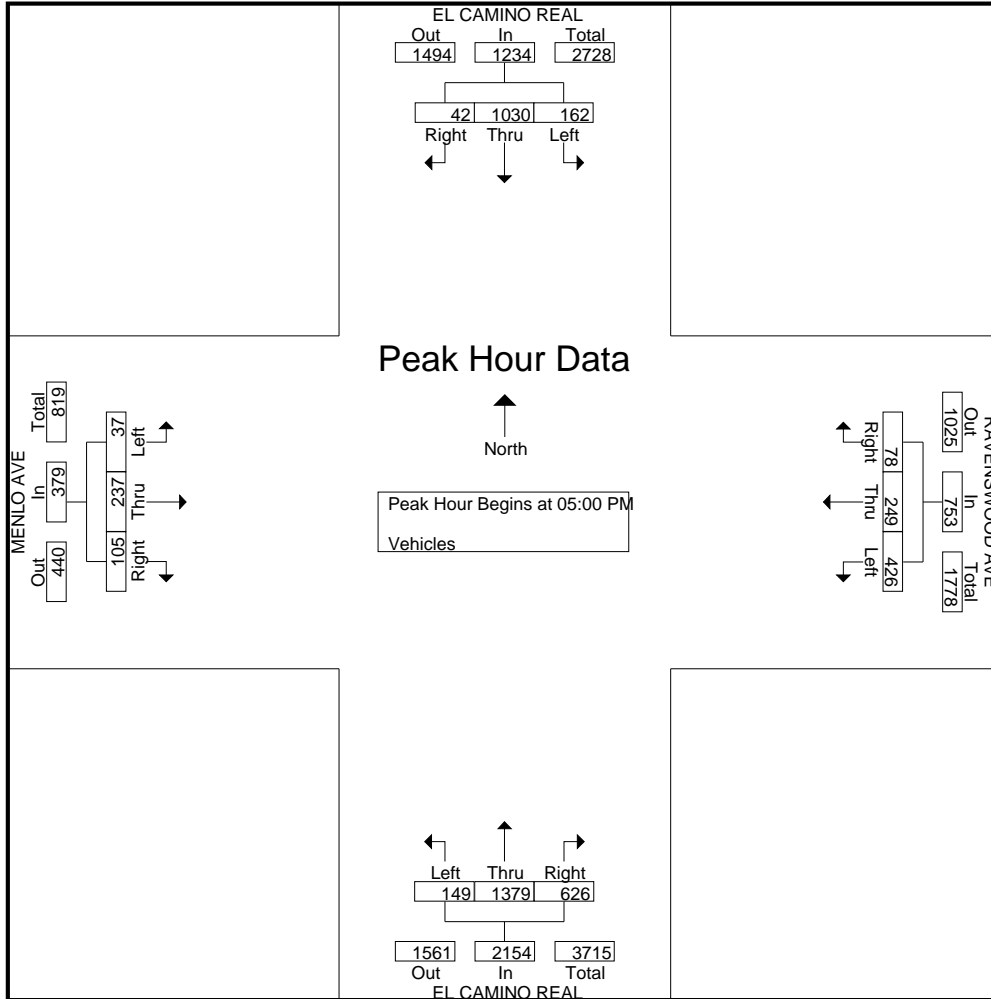

Traffic Data Service

Campbell, CA
 (408) 377-2988
 tdsbay@cs.com

File Name : 82PM FINAL
 Site Code : 00000082
 Start Date : 6/4/2013
 Page No : 1

Groups Printed- Bikes

Start Time	EL CAMINO REAL Southbound					RAVENSWOOD AVE Westbound					EL CAMINO REAL Northbound					MENLO AVE Eastbound					Int. Total
	Right	Thru	Left	Peds	App. Total	Right	Thru	Left	Peds	App. Total	Right	Thru	Left	Peds	App. Total	Right	Thru	Left	Peds	App. Total	
04:00 PM	0	1	0	0	1	0	0	0	0	0	0	0	0	0	0	0	0	0	0	0	1
04:15 PM	0	0	0	0	0	0	1	0	0	1	0	0	0	0	0	0	1	0	0	1	2
04:30 PM	0	1	0	0	1	0	1	0	0	1	0	1	0	0	1	0	0	0	0	0	3
04:45 PM	0	0	0	0	0	1	2	0	0	3	0	2	0	0	2	0	2	0	0	2	7
Total	0	2	0	0	2	1	4	0	0	5	0	3	0	0	3	0	3	0	0	3	13
05:00 PM	0	1	1	0	2	0	1	0	0	1	0	2	0	0	2	0	5	0	0	5	10
05:15 PM	0	1	0	0	1	0	1	1	0	2	0	2	0	0	2	0	2	0	0	2	7
05:30 PM	0	0	0	0	0	1	3	0	0	4	0	1	0	0	1	0	2	0	0	2	7
05:45 PM	0	0	0	0	0	0	5	1	0	6	1	2	0	0	3	0	0	0	0	0	9
Total	0	2	1	0	3	1	10	2	0	13	1	7	0	0	8	0	9	0	0	9	33
Grand Total	0	4	1	0	5	2	14	2	0	18	1	10	0	0	11	0	12	0	0	12	46
Apprch %	0	80	20	0		11.1	77.8	11.1	0		9.1	90.9	0	0		0	100	0	0		
Total %	0	8.7	2.2	0	10.9	4.3	30.4	4.3	0	39.1	2.2	21.7	0	0	23.9	0	26.1	0	0	26.1	

Start Time	EL CAMINO REAL Southbound				RAVENSWOOD AVE Westbound				EL CAMINO REAL Northbound				MENLO AVE Eastbound				Int. Total
	Right	Thru	Left	App. Total	Right	Thru	Left	App. Total	Right	Thru	Left	App. Total	Right	Thru	Left	App. Total	
Peak Hour Analysis From 04:00 PM to 05:45 PM - Peak 1 of 1																	
Peak Hour for Entire Intersection Begins at 05:00 PM																	
05:00 PM	0	1	1	2	0	1	0	1	0	2	0	2	0	5	0	5	10
05:15 PM	0	1	0	1	0	1	1	2	0	2	0	2	0	2	0	2	7
05:30 PM	0	0	0	0	1	3	0	4	0	1	0	1	0	2	0	2	7
05:45 PM	0	0	0	0	0	5	1	6	1	2	0	3	0	0	0	0	9
Total Volume	0	2	1	3	1	10	2	13	1	7	0	8	0	9	0	9	33
% App. Total	0	66.7	33.3		7.7	76.9	15.4		12.5	87.5	0		0	100	0		
PHF	.000	.500	.250	.375	.250	.500	.500	.542	.250	.875	.000	.667	.000	.450	.000	.450	.825

Traffic Data Service

Campbell, CA

(408) 377-2988

tdsbay@cs.com

File Name : 82PM FINAL

Site Code : 00000082

Start Date : 6/4/2013

Page No : 2

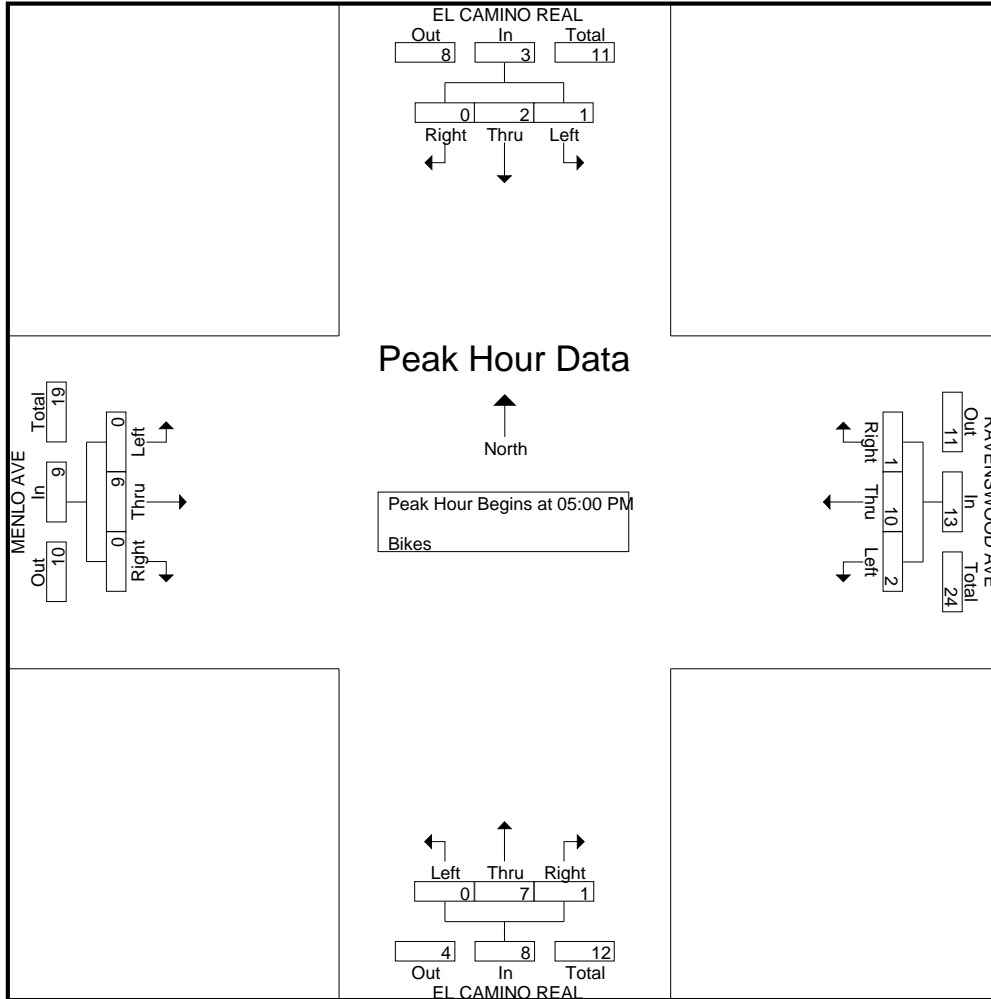

All Traffic Data

(916) 771-8700

City of Menlo Park

File Name : 12-7153-021 Laurel-Ravenswood

Site Code : 00000000

Start Date : 4/17/2012

Page No : 1

Groups Printed- Unshifted

Start Time	Laurel Street Southbound				Ravenswood Avenue Westbound				Laurel Street Northbound				Ravenswood Avenue Eastbound				Int. Total
	Left	Thru	Right	App. Total	Left	Thru	Right	App. Total	Left	Thru	Right	App. Total	Left	Thru	Right	App. Total	
07:00	11	9	2	22	2	69	0	71	17	6	3	26	0	55	8	63	182
07:15	18	13	6	37	4	88	2	94	26	7	1	34	1	78	6	85	250
07:30	21	32	11	64	5	125	2	132	36	23	7	66	1	131	9	141	403
07:45	26	30	14	70	3	121	3	127	35	59	4	98	1	139	13	153	448
Total	76	84	33	193	14	403	7	424	114	95	15	224	3	403	36	442	1283
08:00	39	62	20	121	1	108	5	114	48	25	6	79	2	167	19	188	502
08:15	34	39	17	90	4	127	2	133	45	12	6	63	2	130	18	150	436
08:30	52	32	19	103	8	123	4	135	25	10	6	41	5	129	26	160	439
08:45	29	32	11	72	4	154	4	162	38	13	8	59	1	164	19	184	477
Total	154	165	67	386	17	512	15	544	156	60	26	242	10	590	82	682	1854
16:00	18	28	8	54	5	140	6	151	28	26	11	65	8	147	15	170	440
16:15	14	29	10	53	6	114	2	122	40	20	10	70	9	129	28	166	411
16:30	19	28	6	53	5	115	5	125	50	33	13	96	12	138	13	163	437
16:45	8	39	20	67	7	143	5	155	55	26	12	93	14	156	19	189	504
Total	59	124	44	227	23	512	18	553	173	105	46	324	43	570	75	688	1792
17:00	15	31	8	54	8	119	17	144	38	34	8	80	17	165	18	200	478
17:15	18	28	9	55	10	134	7	151	53	39	12	104	12	164	32	208	518
17:30	14	29	11	54	5	141	8	154	43	34	10	87	11	184	31	226	521
17:45	12	17	8	37	8	169	2	179	43	33	9	85	11	153	25	189	490
Total	59	105	36	200	31	563	34	628	177	140	39	356	51	666	106	823	2007
Grand Total	348	478	180	1006	85	1990	74	2149	620	400	126	1146	107	2229	299	2635	6936
Apprch %	34.6	47.5	17.9		4	92.6	3.4		54.1	34.9	11		4.1	84.6	11.3		
Total %	5	6.9	2.6	14.5	1.2	28.7	1.1	31	8.9	5.8	1.8	16.5	1.5	32.1	4.3	38	

Start Time	Laurel Street Southbound				Ravenswood Avenue Westbound				Laurel Street Northbound				Ravenswood Avenue Eastbound				Int. Total
	Left	Thru	Right	App. Total	Left	Thru	Right	App. Total	Left	Thru	Right	App. Total	Left	Thru	Right	App. Total	
Peak Hour Analysis From 07:00 to 08:45 - Peak 1 of 1																	
Peak Hour for Entire Intersection Begins at 08:00																	
08:00	39	62	20	121	1	108	5	114	48	25	6	79	2	167	19	188	502
08:15	34	39	17	90	4	127	2	133	45	12	6	63	2	130	18	150	436
08:30	52	32	19	103	8	123	4	135	25	10	6	41	5	129	26	160	439
08:45	29	32	11	72	4	154	4	162	38	13	8	59	1	164	19	184	477
Total Volume	154	165	67	386	17	512	15	544	156	60	26	242	10	590	82	682	1854
% App. Total	39.9	42.7	17.4		3.1	94.1	2.8		64.5	24.8	10.7		1.5	86.5	12		

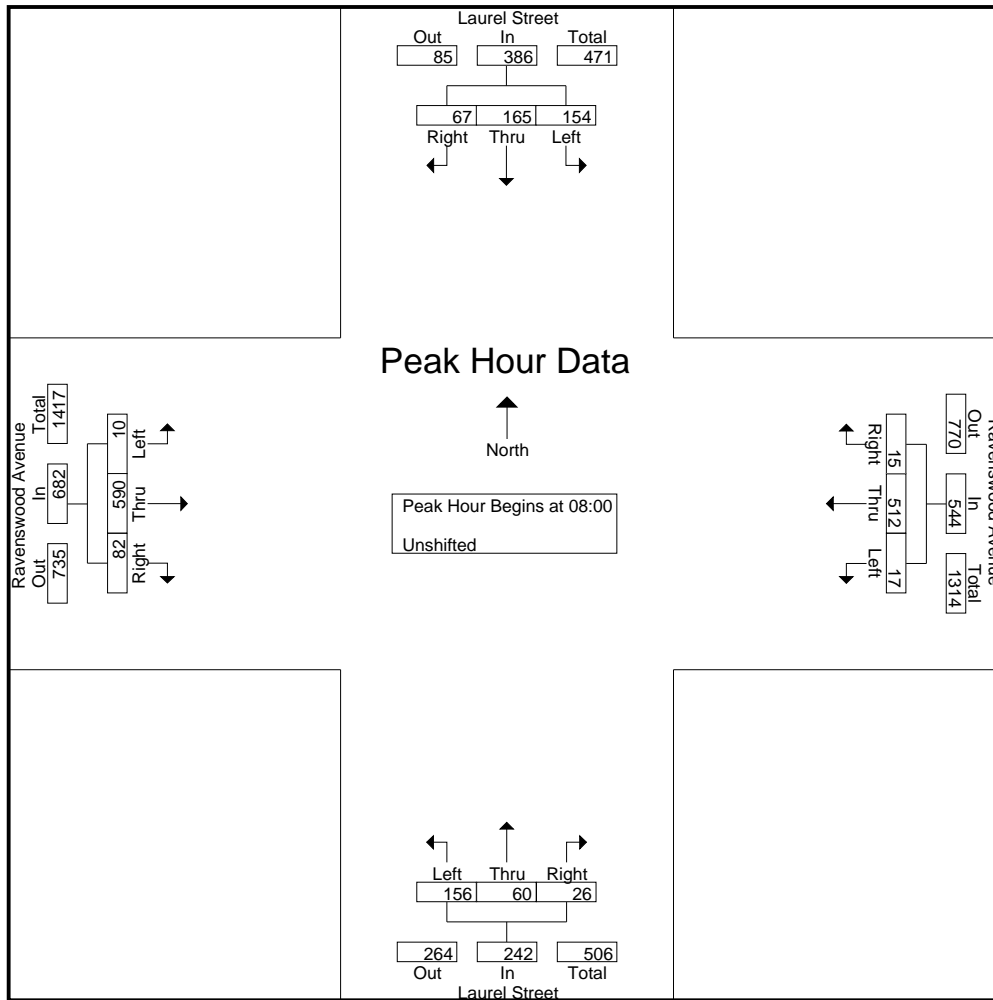

Peak Hour Analysis From 16:00 to 17:45 - Peak 1 of 1
 Peak Hour for Entire Intersection Begins at 16:45

16:45	8	39	20	67	7	143	5	155	55	26	12	93	14	156	19	189	504
17:00	15	31	8	54	8	119	17	144	38	34	8	80	17	165	18	200	478
17:15	18	28	9	55	10	134	7	151	53	39	12	104	12	164	32	208	518
17:30	14	29	11	54	5	141	8	154	43	34	10	87	11	184	31	226	521
Total Volume	55	127	48	230	30	537	37	604	189	133	42	364	54	669	100	823	2021
% App. Total	23.9	55.2	20.9		5	88.9	6.1		51.9	36.5	11.5		6.6	81.3	12.2		
PHF	.764	.814	.600	.858	.750	.939	.544	.974	.859	.853	.875	.875	.794	.909	.781	.910	.970

All Traffic Data

(916) 771-8700

City of Menlo Park

File Name : 12-7153-021 Laurel-Ravenswood

Site Code : 00000000

Start Date : 4/17/2012

Page No : 3

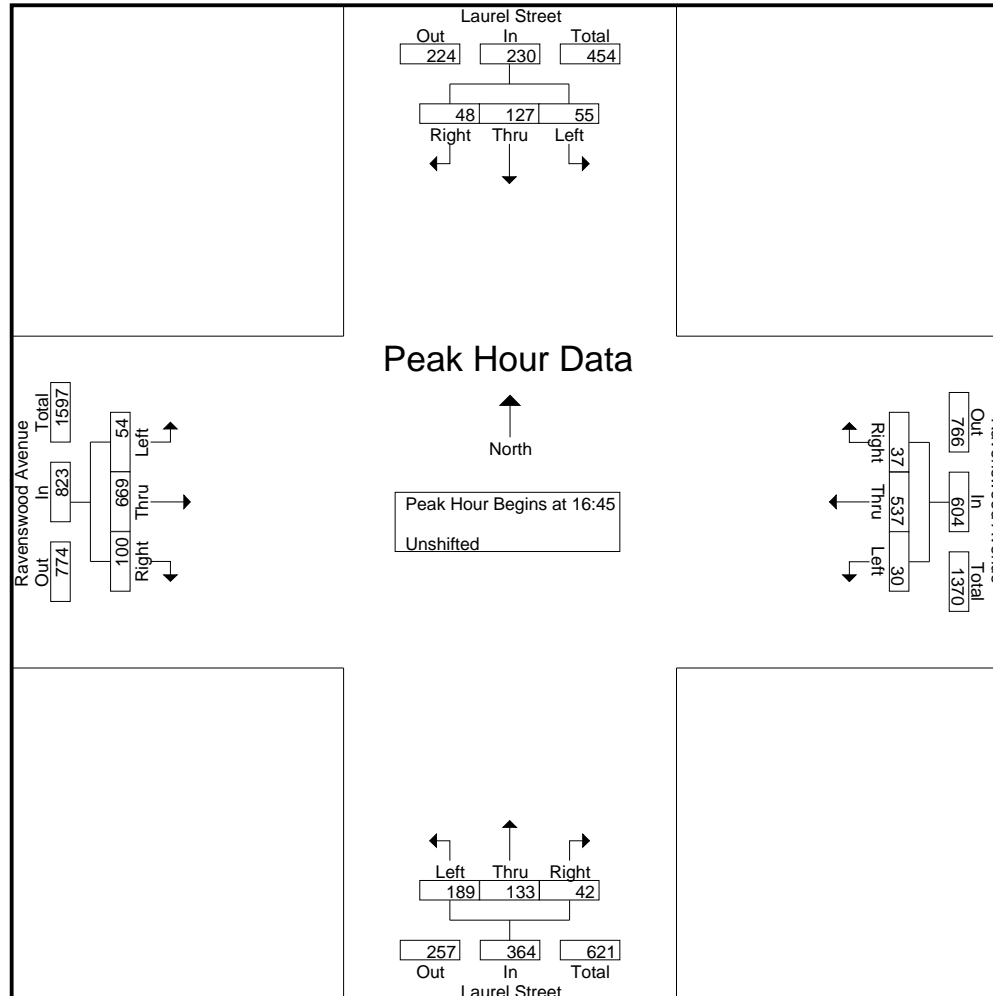

All Traffic Data

(916) 771-8700

City of Palo Alto

File Name : 12-7153-022 Alma-Palo Alto

Site Code : 00000000

Start Date : 4/17/2012

Page No : 1

Groups Printed- Unshifted

Start Time	Alma Street Southbound				Palo Alto Avenue Westbound				Alma Street Northbound				Eastbound				Int. Total
	Left	Thru	Right	App. Total	Left	Thru	Right	App. Total	Left	Thru	Right	App. Total	Left	Thru	Right	App. Total	
07:00	0	60	0	60	0	0	2	2	0	62	0	62	0	0	0	0	124
07:15	0	76	0	76	1	0	1	2	0	75	1	76	0	0	0	0	154
07:30	0	94	0	94	0	0	3	3	0	107	2	109	0	0	0	0	206
07:45	0	130	0	130	4	0	4	8	0	112	4	116	0	0	0	0	254
Total	0	360	0	360	5	0	10	15	0	356	7	363	0	0	0	0	738
08:00	0	132	0	132	3	0	4	7	0	121	1	122	0	0	0	0	261
08:15	0	110	0	110	2	0	8	10	0	128	7	135	0	0	0	0	255
08:30	0	130	0	130	2	0	3	5	0	125	4	129	0	0	0	0	264
08:45	0	110	0	110	2	0	4	6	0	117	2	119	0	0	0	0	235
Total	0	482	0	482	9	0	19	28	0	491	14	505	0	0	0	0	1015
16:00	0	140	0	140	1	0	1	2	0	183	3	186	0	0	0	0	328
16:15	0	106	0	106	3	0	7	10	0	170	1	171	0	0	0	0	287
16:30	0	131	0	131	1	0	9	10	0	157	3	160	0	0	0	0	301
16:45	0	131	0	131	2	0	3	5	0	180	5	185	0	0	0	0	321
Total	0	508	0	508	7	0	20	27	0	690	12	702	0	0	0	0	1237
17:00	0	135	0	135	3	0	2	5	0	139	6	145	0	0	0	0	285
17:15	0	131	0	131	0	0	8	8	0	171	0	171	0	0	0	0	310
17:30	0	130	0	130	1	0	6	7	0	215	4	219	0	0	0	0	356
17:45	0	130	0	130	1	0	5	6	0	171	3	174	0	0	0	0	310
Total	0	526	0	526	5	0	21	26	0	696	13	709	0	0	0	0	1261
Grand Total	0	1876	0	1876	26	0	70	96	0	2233	46	2279	0	0	0	0	4251
Apprch %	0	100	0		27.1	0	72.9		0	98	2		0	0	0		
Total %	0	44.1	0	44.1	0.6	0	1.6	2.3	0	52.5	1.1	53.6	0	0	0	0	

Start Time	Alma Street Southbound				Palo Alto Avenue Westbound				Alma Street Northbound				Eastbound				Int. Total
	Left	Thru	Right	App. Total	Left	Thru	Right	App. Total	Left	Thru	Right	App. Total	Left	Thru	Right	App. Total	
Peak Hour Analysis From 07:00 to 08:45 - Peak 1 of 1																	
Peak Hour for Entire Intersection Begins at 07:45																	
07:45	0	130	0	130	4	0	4	8	0	112	4	116	0	0	0	0	254
08:00	0	132	0	132	3	0	4	7	0	121	1	122	0	0	0	0	261
08:15	0	110	0	110	2	0	8	10	0	128	7	135	0	0	0	0	255
08:30	0	130	0	130	2	0	3	5	0	125	4	129	0	0	0	0	264
Total Volume	0	502	0	502	11	0	19	30	0	486	16	502	0	0	0	0	1034
% App. Total	0	100	0		36.7	0	63.3		0	96.8	3.2		0	0	0		

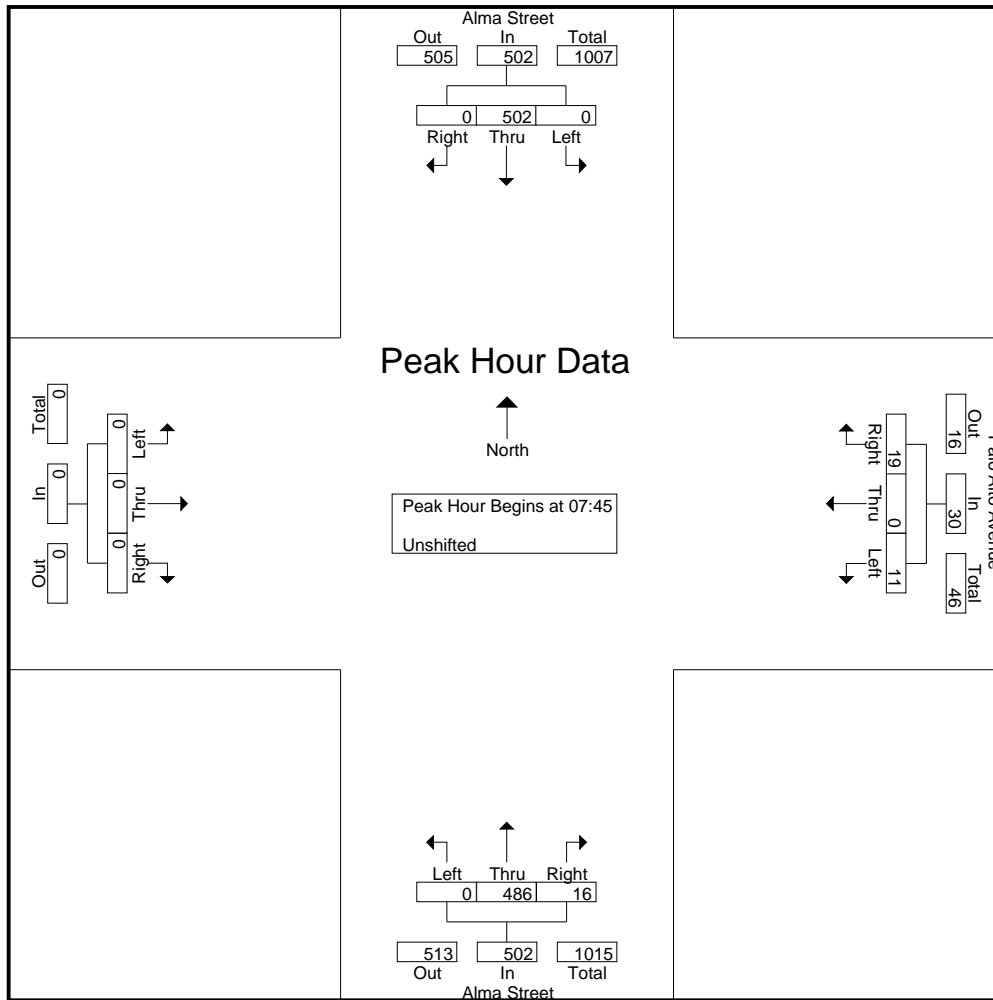

Peak Hour Analysis From 16:00 to 17:45 - Peak 1 of 1
Peak Hour for Entire Intersection Begins at 16:45

16:45	0	131	0	131	2	0	3	5	0	180	5	185	0	0	0	0	321
17:00	0	135	0	135	3	0	2	5	0	139	6	145	0	0	0	0	285
17:15	0	131	0	131	0	0	8	8	0	171	0	171	0	0	0	0	310
17:30	0	130	0	130	1	0	6	7	0	215	4	219	0	0	0	0	356
Total Volume	0	527	0	527	6	0	19	25	0	705	15	720	0	0	0	0	1272
% App. Total	0	100	0		24	0	76		0	97.9	2.1		0	0	0		
PHF	.000	.976	.000	.976	.500	.000	.594	.781	.000	.820	.625	.822	.000	.000	.000	.000	.893

All Traffic Data

(916) 771-8700

City of Palo Alto

File Name : 12-7153-022 Alma-Palo Alto

Site Code : 00000000

Start Date : 4/17/2012

Page No : 3

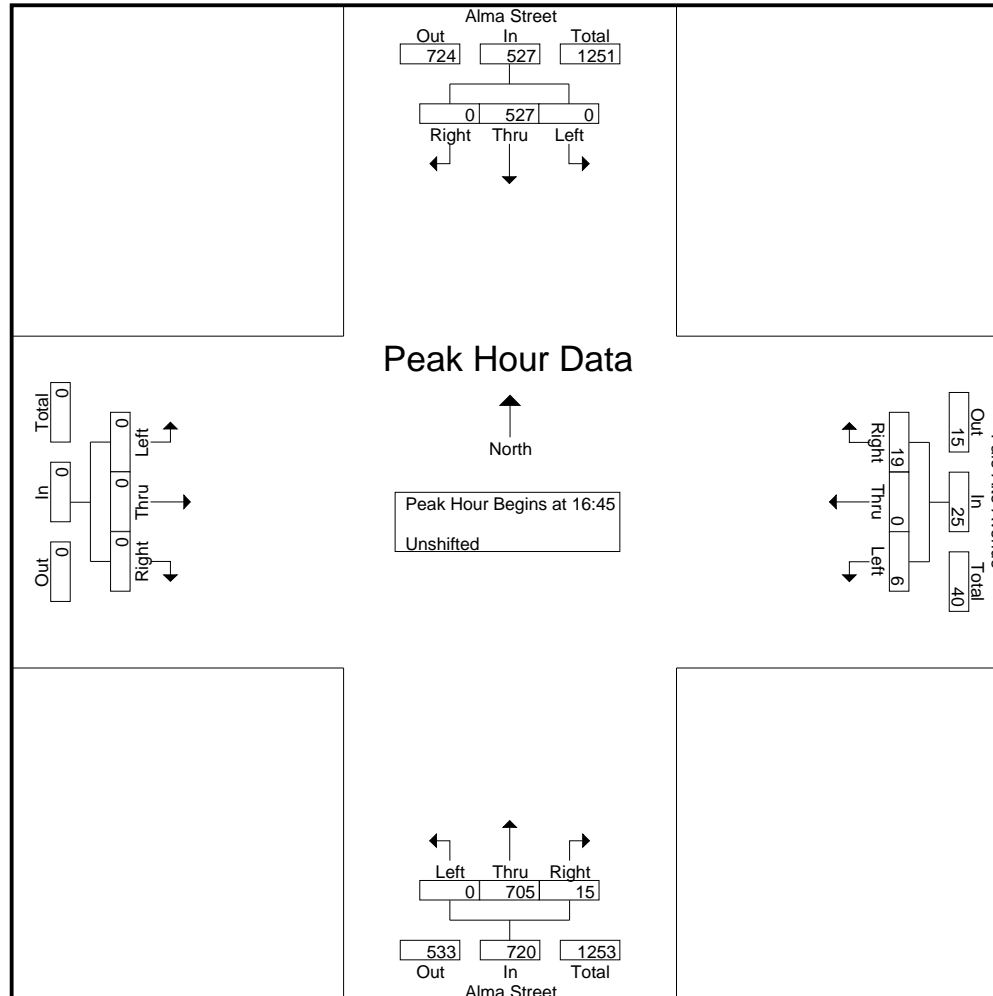

Groups Printed- Vehicles Only

Start Time	ALMA ST Southbound				MEADOW DR Westbound				ALMA ST Northbound				MEADOW DR Eastbound				Int. Total
	RT	TH	LT	App. Total	RT	TH	LT	App. Total	RT	TH	LT	App. Total	RT	TH	LT	App. Total	
07:30	18	93	7	118	16	27	10	53	8	300	20	328	17	25	21	63	562
07:45	48	135	18	201	14	67	11	92	13	306	32	351	13	62	26	101	745
Total	66	228	25	319	30	94	21	145	21	606	52	679	30	87	47	164	1307
08:00	48	135	17	200	22	81	22	125	18	259	38	315	14	36	37	87	727
08:15	44	160	11	215	20	54	19	93	13	301	14	328	22	55	48	125	761
08:30	29	154	15	198	23	49	30	102	14	320	26	360	17	45	38	100	760
08:45	18	180	10	208	18	30	35	83	14	312	34	360	29	36	40	105	756
Total	139	629	53	821	83	214	106	403	59	1192	112	1363	82	172	163	417	3004
09:00	16	147	9	172	18	40	11	69	12	259	11	282	12	38	34	84	607
09:15	20	152	7	179	20	48	23	91	8	317	21	346	6	29	37	72	688
Grand Total	241	1156	94	1491	151	396	161	708	100	2374	196	2670	130	326	281	737	5606
Apprch %	16.2	77.5	6.3		21.3	55.9	22.7		3.7	88.9	7.3		17.6	44.2	38.1		
Total %	4.3	20.6	1.7	26.6	2.7	7.1	2.9	12.6	1.8	42.3	3.5	47.6	2.3	5.8	5	13.1	

Start Time	ALMA ST Southbound				MEADOW DR Westbound				ALMA ST Northbound				MEADOW DR Eastbound				Int. Total
	RT	TH	LT	App. Total	RT	TH	LT	App. Total	RT	TH	LT	App. Total	RT	TH	LT	App. Total	

Peak Hour Analysis From 07:30 to 09:15 - Peak 1 of 1
 Peak Hour for Entire Intersection Begins at 08:00

08:00	48	135	17	200	22	81	22	125	18	259	38	315	14	36	37	87	727
08:15	44	160	11	215	20	54	19	93	13	301	14	328	22	55	48	125	761
08:30	29	154	15	198	23	49	30	102	14	320	26	360	17	45	38	100	760
08:45	18	180	10	208	18	30	35	83	14	312	34	360	29	36	40	105	756
Total Volume	139	629	53	821	83	214	106	403	59	1192	112	1363	82	172	163	417	3004
% App. Total	16.9	76.6	6.5		20.6	53.1	26.3		4.3	87.5	8.2		19.7	41.2	39.1		
PHF	.724	.874	.779	.955	.902	.660	.757	.806	.819	.931	.737	.947	.707	.782	.849	.834	.987

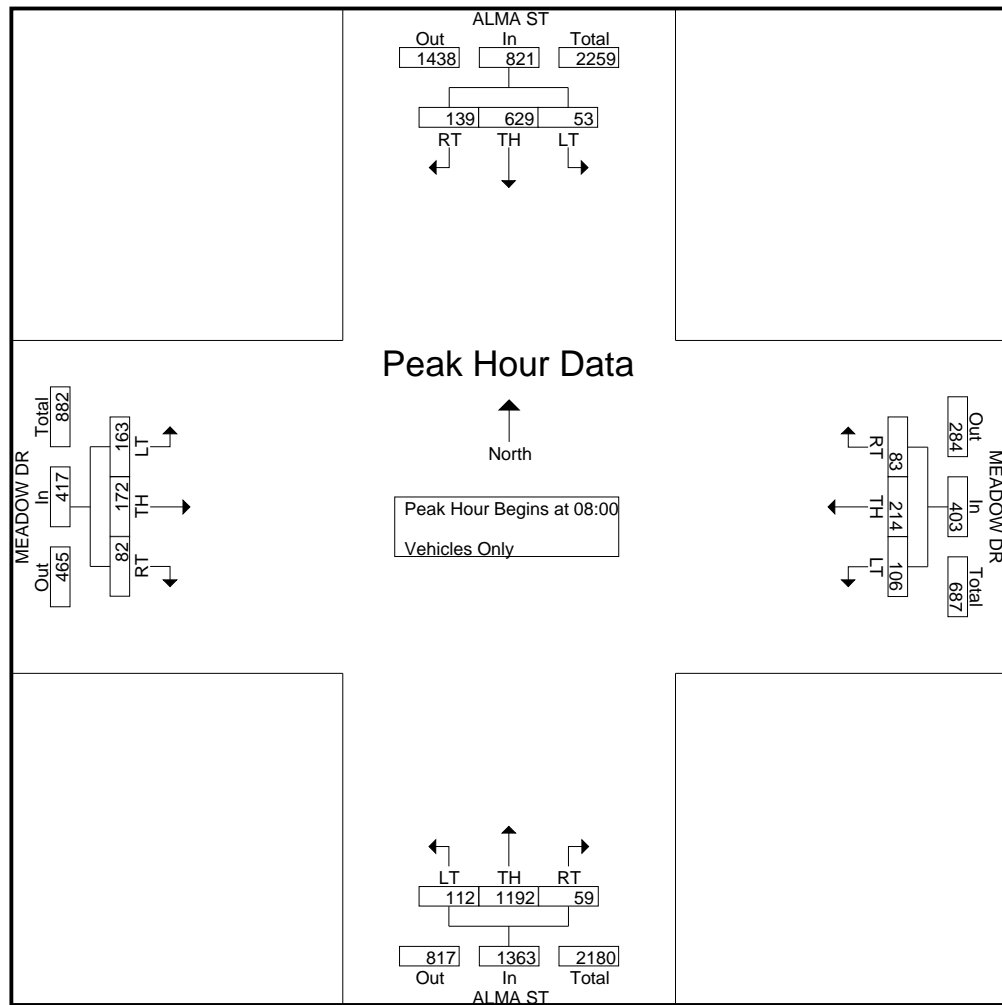

MARKS TRAFFIC DATA

mietekm@comcast.net
916.806.0250

CITY OF PALO ALTO
Task A

File Name : alma-meadow-p
Site Code : 10
Start Date : 5/7/2013
Page No : 1

Groups Printed- Vehicles Only

Start Time	ALMA ST Southbound				E. MEADOW DR Westbound				ALMA ST Northbound				W. MEADOW DR Eastbound				Int. Total
	RT	TH	LT	App. Total	RT	TH	LT	App. Total	RT	TH	LT	App. Total	RT	TH	LT	App. Total	
17:00	17	303	6	326	18	62	19	99	14	222	19	255	17	51	33	101	781
17:15	34	349	18	401	25	63	22	110	16	262	14	292	13	45	28	86	889
17:30	29	281	15	325	19	37	12	68	24	239	12	275	21	53	31	105	773
17:45	45	310	28	383	17	55	21	93	12	285	11	308	19	46	28	93	877
Total	125	1243	67	1435	79	217	74	370	66	1008	56	1130	70	195	120	385	3320
18:00	29	255	8	292	25	53	29	107	16	226	21	263	22	45	22	89	751
18:15	25	257	16	298	12	38	14	64	16	261	19	296	18	34	22	74	732
18:30	29	266	11	306	13	31	19	63	13	262	22	297	16	24	25	65	731
18:45	33	231	19	283	26	27	24	77	9	214	19	242	7	41	16	64	666
Total	116	1009	54	1179	76	149	86	311	54	963	81	1098	63	144	85	292	2880
Grand Total	241	2252	121	2614	155	366	160	681	120	1971	137	2228	133	339	205	677	6200
Apprch %	9.2	86.2	4.6		22.8	53.7	23.5		5.4	88.5	6.1		19.6	50.1	30.3		
Total %	3.9	36.3	2	42.2	2.5	5.9	2.6	11	1.9	31.8	2.2	35.9	2.1	5.5	3.3	10.9	

Start Time	ALMA ST Southbound				E. MEADOW DR Westbound				ALMA ST Northbound				W. MEADOW DR Eastbound				Int. Total
	RT	TH	LT	App. Total	RT	TH	LT	App. Total	RT	TH	LT	App. Total	RT	TH	LT	App. Total	

Peak Hour Analysis From 17:00 to 18:45 - Peak 1 of 1

Peak Hour for Entire Intersection Begins at 17:00

17:00	17	303	6	326	18	62	19	99	14	222	19	255	17	51	33	101	781
17:15	34	349	18	401	25	63	22	110	16	262	14	292	13	45	28	86	889
17:30	29	281	15	325	19	37	12	68	24	239	12	275	21	53	31	105	773
17:45	45	310	28	383	17	55	21	93	12	285	11	308	19	46	28	93	877
Total Volume	125	1243	67	1435	79	217	74	370	66	1008	56	1130	70	195	120	385	3320
% App. Total	8.7	86.6	4.7		21.4	58.6	20		5.8	89.2	5		18.2	50.6	31.2		
PHF	.694	.890	.598	.895	.790	.861	.841	.841	.688	.884	.737	.917	.833	.920	.909	.917	.934

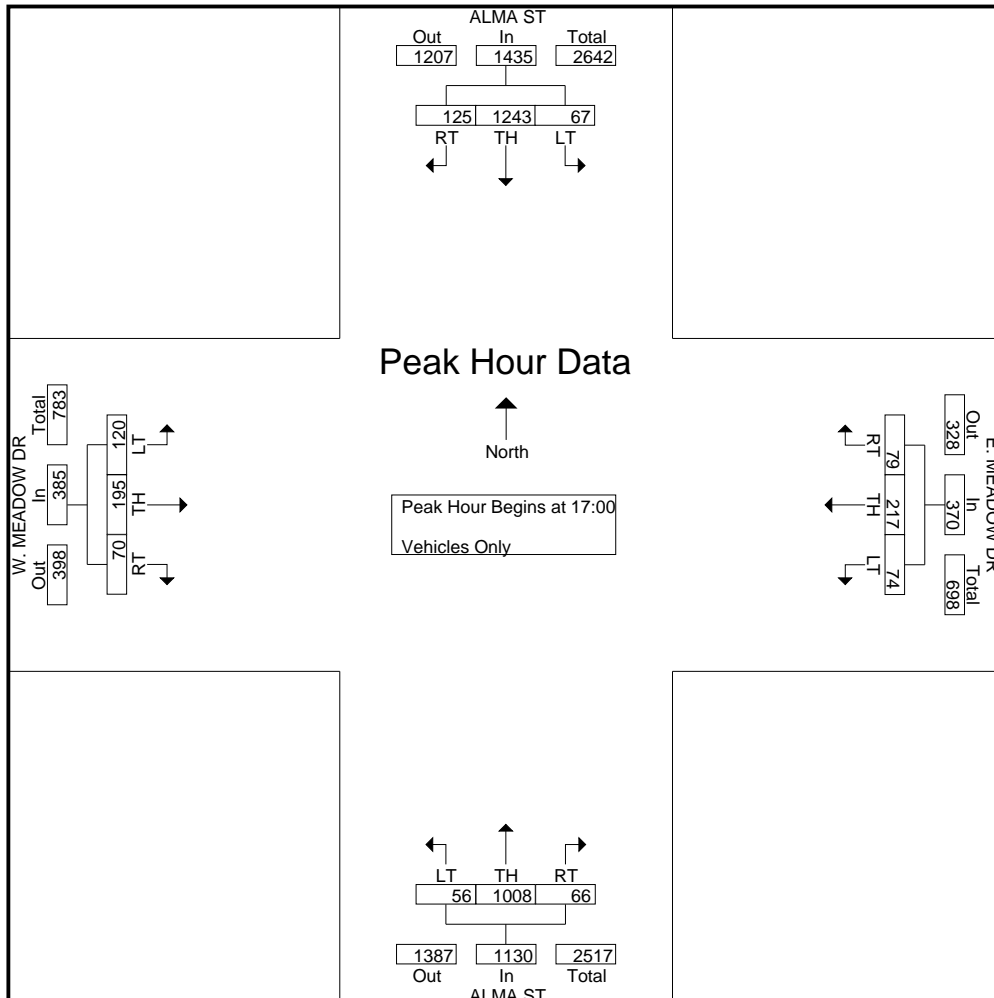

Traffic Data Service

Campbell, CA
 (408) 377-2988
 tdsbay@cs.com

File Name : 23AM FINAL
 Site Code : 00000023
 Start Date : 5/22/2013
 Page No : 1

Groups Printed- Bikes

Start Time	EL CAMINO REAL Southbound					PALO ALTO AVE Westbound					EL CAMINO REAL Northbound					SAND HILL RD Eastbound					Int. Total	
	Right	Thru	Left	Peds	App. Total	Right	Thru	Left	Peds	App. Total	Right	Thru	Left	Peds	App. Total	Right	Thru	Left	Peds	App. Total		
07:00 AM	0	0	1	0	1	1	0	0	0	1	0	0	0	0	0	0	0	0	0	0	0	2
07:15 AM	2	0	1	0	3	0	0	0	0	0	0	0	0	0	0	0	0	0	0	0	0	3
07:30 AM	2	3	0	0	5	0	0	0	0	0	0	0	0	0	0	1	0	0	0	0	1	6
07:45 AM	0	4	0	0	4	0	0	0	0	0	0	0	1	0	1	0	0	0	0	0	0	5
Total	4	7	2	0	13	1	0	0	0	1	0	0	1	0	1	1	0	0	0	0	1	16
08:00 AM	7	2	0	0	9	0	0	0	0	0	0	0	0	0	0	0	0	0	0	0	0	9
08:15 AM	8	0	0	0	8	0	0	0	0	0	0	0	0	0	0	0	0	0	0	0	0	8
08:30 AM	10	1	0	0	11	1	0	0	0	1	0	0	0	0	0	0	0	1	0	0	1	13
08:45 AM	12	1	0	0	13	0	0	0	0	0	0	1	0	0	1	0	0	1	0	0	1	15
Total	37	4	0	0	41	1	0	0	0	1	0	1	0	0	1	0	0	2	0	2	45	
Grand Total	41	11	2	0	54	2	0	0	0	2	0	1	1	0	2	1	0	2	0	3	61	
Apprch %	75.9	20.4	3.7	0		100	0	0	0		0	50	50	0		33.3	0	66.7	0			
Total %	67.2	18	3.3	0	88.5	3.3	0	0	0	3.3	0	1.6	1.6	0	3.3	1.6	0	3.3	0	4.9		

Start Time	EL CAMINO REAL Southbound					PALO ALTO AVE Westbound					EL CAMINO REAL Northbound					SAND HILL RD Eastbound					Int. Total
	Right	Thru	Left	Peds	App. Total	Right	Thru	Left	Peds	App. Total	Right	Thru	Left	Peds	App. Total	Right	Thru	Left	Peds	App. Total	
08:00 AM	7	2	0	0	9	0	0	0	0	0	0	0	0	0	0	0	0	0	0	0	9
08:15 AM	8	0	0	0	8	0	0	0	0	0	0	0	0	0	0	0	0	0	0	0	8
08:30 AM	10	1	0	0	11	1	0	0	0	1	0	0	0	0	0	0	0	1	0	1	13
08:45 AM	12	1	0	0	13	0	0	0	0	0	0	1	0	0	1	0	0	1	0	1	15
Total Volume	37	4	0	0	41	1	0	0	0	1	0	1	0	0	1	0	0	2	0	2	45
% App. Total	90.2	9.8	0	0		100	0	0	0		0	100	0	0		0	0	100	0		
PHF	.771	.500	.000	.000	.788	.250	.000	.000	.000	.250	.000	.250	.000	.250	.000	.000	.000	.500	.500	.000	.750

Peak Hour Analysis From 07:00 AM to 08:45 AM - Peak 1 of 1

Peak Hour for Entire Intersection Begins at 08:00 AM

Traffic Data Service

Campbell, CA
(408) 377-2988
tdsbay@cs.com

File Name : 23AM FINAL
Site Code : 00000023
Start Date : 5/22/2013
Page No : 2

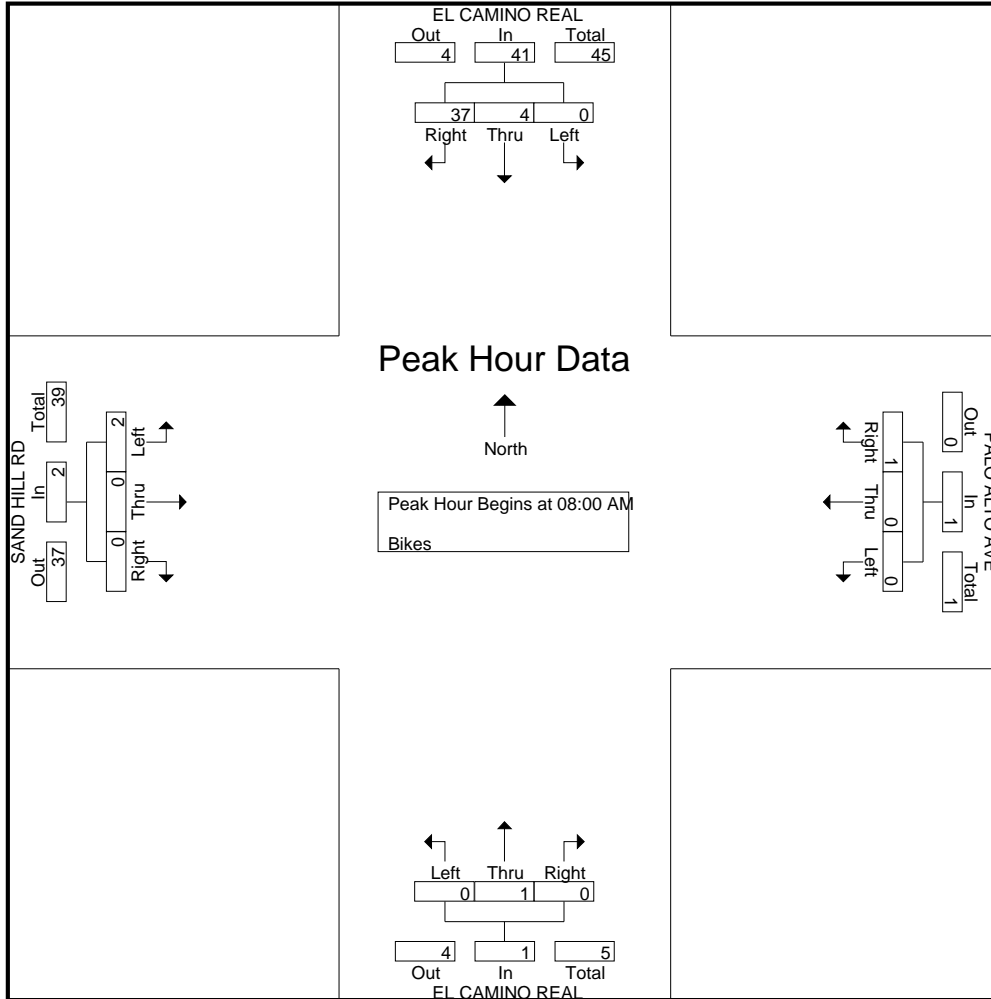

Traffic Data Service

Campbell, CA
 (408) 377-2988
 tdsbay@cs.com

File Name : 23AM FINAL
 Site Code : 00000023
 Start Date : 5/22/2013
 Page No : 1

Groups Printed- Vehicles

Start Time	EL CAMINO REAL Southbound					PALO ALTO AVE Westbound					EL CAMINO REAL Northbound					SAND HILL RD Eastbound					Int. Total
	Right	Thru	Left	Peds	App. Total	Right	Thru	Left	Peds	App. Total	Right	Thru	Left	Peds	App. Total	Right	Thru	Left	Peds	App. Total	
07:00 AM	57	152	64	9	282	51	0	0	0	51	1	91	31	3	126	28	0	39	0	67	526
07:15 AM	97	187	71	5	360	73	0	0	1	74	4	86	30	3	123	35	0	55	1	91	648
07:30 AM	96	273	89	21	479	106	0	0	2	108	3	114	34	2	153	45	0	58	6	109	849
07:45 AM	92	326	99	17	534	123	0	0	0	123	3	137	26	3	169	66	0	68	4	138	964
Total	342	938	323	52	1655	353	0	0	3	356	11	428	121	11	571	174	0	220	11	405	2987
08:00 AM	104	320	99	24	547	114	0	0	0	114	5	137	36	5	183	54	0	79	3	136	980
08:15 AM	104	299	107	20	530	124	0	0	2	126	5	113	38	3	159	55	0	62	6	123	938
08:30 AM	115	336	98	26	575	117	0	0	4	121	4	127	29	6	166	53	0	64	3	120	982
08:45 AM	119	374	94	18	605	147	0	0	3	150	7	187	35	5	234	63	0	69	5	137	1126
Total	442	1329	398	88	2257	502	0	0	9	511	21	564	138	19	742	225	0	274	17	516	4026
Grand Total	784	2267	721	140	3912	855	0	0	12	867	32	992	259	30	1313	399	0	494	28	921	7013
Apprch %	20	57.9	18.4	3.6		98.6	0	0	1.4		2.4	75.6	19.7	2.3		43.3	0	53.6	3		
Total %	11.2	32.3	10.3	2	55.8	12.2	0	0	0.2	12.4	0.5	14.1	3.7	0.4	18.7	5.7	0	7	0.4	13.1	

Start Time	EL CAMINO REAL Southbound					PALO ALTO AVE Westbound					EL CAMINO REAL Northbound					SAND HILL RD Eastbound					Int. Total
	Right	Thru	Left	Peds	App. Total	Right	Thru	Left	Peds	App. Total	Right	Thru	Left	Peds	App. Total	Right	Thru	Left	Peds	App. Total	
Peak Hour Analysis From 07:00 AM to 08:45 AM - Peak 1 of 1																					
Peak Hour for Entire Intersection Begins at 08:00 AM																					
08:00 AM	104	320	99		523	114	0	0		114	5	137	36		178	54	0	79		133	948
08:15 AM	104	299	107		510	124	0	0		124	5	113	38		156	55	0	62		117	907
08:30 AM	115	336	98		549	117	0	0		117	4	127	29		160	53	0	64		117	943
08:45 AM	119	374	94		587	147	0	0		147	7	187	35		229	63	0	69		132	1095
Total Volume	442	1329	398		2169	502	0	0		502	21	564	138		723	225	0	274		499	3893
% App. Total	20.4	61.3	18.3			100	0	0			2.9	78	19.1			45.1	0	54.9			
PHF	.929	.888	.930		.924	.854	.000	.000		.854	.750	.754	.908		.789	.893	.000	.867		.938	.889

Traffic Data Service

Campbell, CA
 (408) 377-2988
 tdsbay@cs.com

File Name : 23AM FINAL
 Site Code : 00000023
 Start Date : 5/22/2013
 Page No : 2

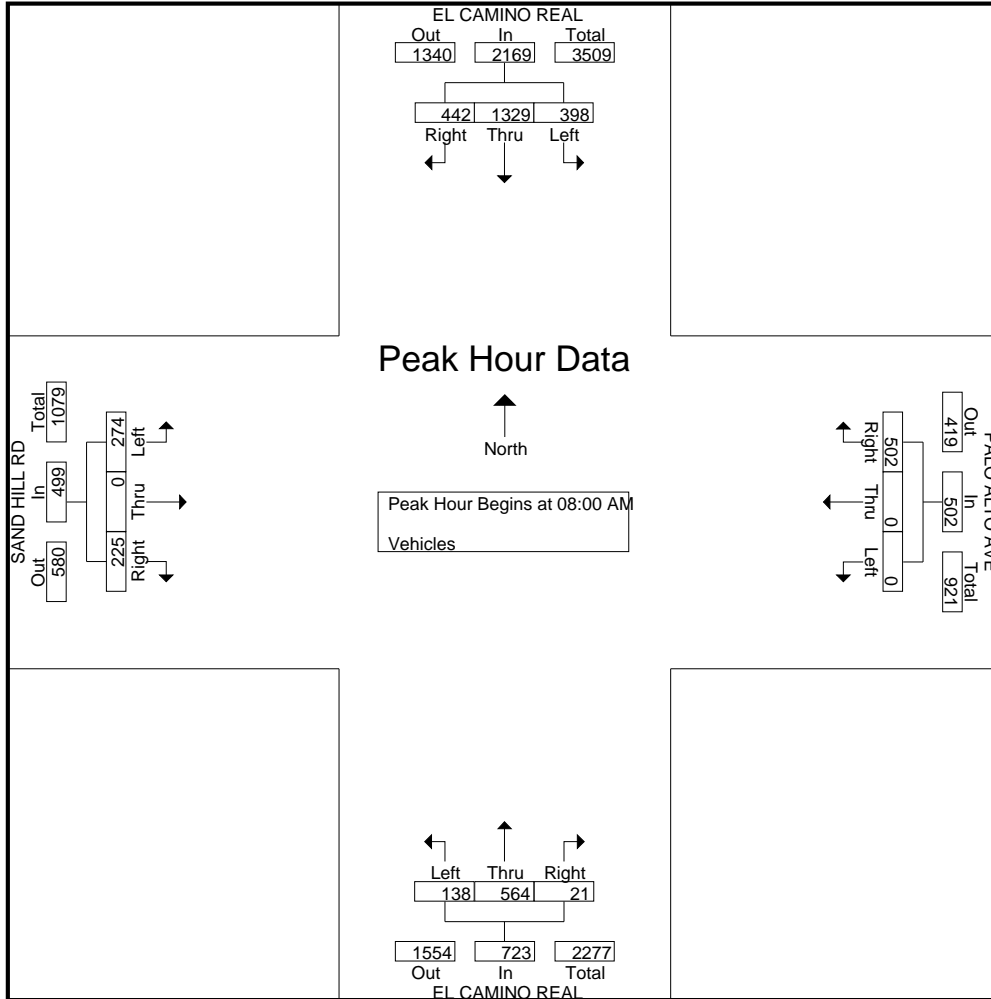

Traffic Data Service

Campbell, CA
 (408) 377-2988
 tdsbay@cs.com

File Name : 23PM FINAL
 Site Code : 00000023
 Start Date : 5/22/2013
 Page No : 1

Groups Printed- Vehicles

Start Time	EL CAMINO REAL Southbound					PALO ALTO AVE Westbound					EL CAMINO REAL Northbound					SAND HILL RD Eastbound					Int. Total
	Right	Thru	Left	Peds	App. Total	Right	Thru	Left	Peds	App. Total	Right	Thru	Left	Peds	App. Total	Right	Thru	Left	Peds	App. Total	
04:00 PM	92	199	89	4	384	173	0	0	0	173	26	281	47	1	355	42	0	129	4	175	1087
04:15 PM	98	235	93	2	428	169	0	0	0	169	17	273	48	3	341	62	0	123	3	188	1126
04:30 PM	79	216	97	2	394	165	0	0	0	165	17	290	49	6	362	49	0	138	2	189	1110
04:45 PM	67	231	94	9	401	190	0	0	0	190	32	300	29	7	368	48	0	130	4	182	1141
Total	336	881	373	17	1607	697	0	0	0	697	92	1144	173	17	1426	201	0	520	13	734	4464
05:00 PM	64	253	93	10	420	193	0	0	2	195	25	305	43	13	386	55	0	149	0	204	1205
05:15 PM	49	244	99	10	402	173	0	0	2	175	27	350	38	10	425	79	0	129	0	208	1210
05:30 PM	52	239	112	8	411	164	0	0	0	164	34	328	32	6	400	46	0	123	0	169	1144
05:45 PM	44	221	94	8	367	147	0	0	8	155	19	343	37	9	408	47	0	127	0	174	1104
Total	209	957	398	36	1600	677	0	0	12	689	105	1326	150	38	1619	227	0	528	0	755	4663
Grand Total	545	1838	771	53	3207	1374	0	0	12	1386	197	2470	323	55	3045	428	0	1048	13	1489	9127
Apprch %	17	57.3	24	1.7		99.1	0	0	0.9		6.5	81.1	10.6	1.8		28.7	0	70.4	0.9		
Total %	6	20.1	8.4	0.6	35.1	15.1	0	0	0.1	15.2	2.2	27.1	3.5	0.6	33.4	4.7	0	11.5	0.1	16.3	

Start Time	EL CAMINO REAL Southbound					PALO ALTO AVE Westbound					EL CAMINO REAL Northbound					SAND HILL RD Eastbound					Int. Total
	Right	Thru	Left	Peds	App. Total	Right	Thru	Left	Peds	App. Total	Right	Thru	Left	Peds	App. Total	Right	Thru	Left	Peds	App. Total	
04:45 PM	67	231	94		392	190	0	0		190	32	300	29		361	48	0	130		178	1121
05:00 PM	64	253	93		410	193	0	0		193	25	305	43		373	55	0	149		204	1180
05:15 PM	49	244	99		392	173	0	0		173	27	350	38		415	79	0	129		208	1188
05:30 PM	52	239	112		403	164	0	0		164	34	328	32		394	46	0	123		169	1130
Total Volume	232	967	398		1597	720	0	0		720	118	1283	142		1543	228	0	531		759	4619
% App. Total	14.5	60.6	24.9			100	0	0			7.6	83.1	9.2			30	0	70			
PHF	.866	.956	.888		.974	.933	.000	.000		.933	.868	.916	.826		.930	.722	.000	.891		.912	.972

Peak Hour Analysis From 04:00 PM to 05:45 PM - Peak 1 of 1

Peak Hour for Entire Intersection Begins at 04:45 PM

Traffic Data Service

Campbell, CA
 (408) 377-2988
 tdsbay@cs.com

File Name : 23PM FINAL
 Site Code : 00000023
 Start Date : 5/22/2013
 Page No : 2

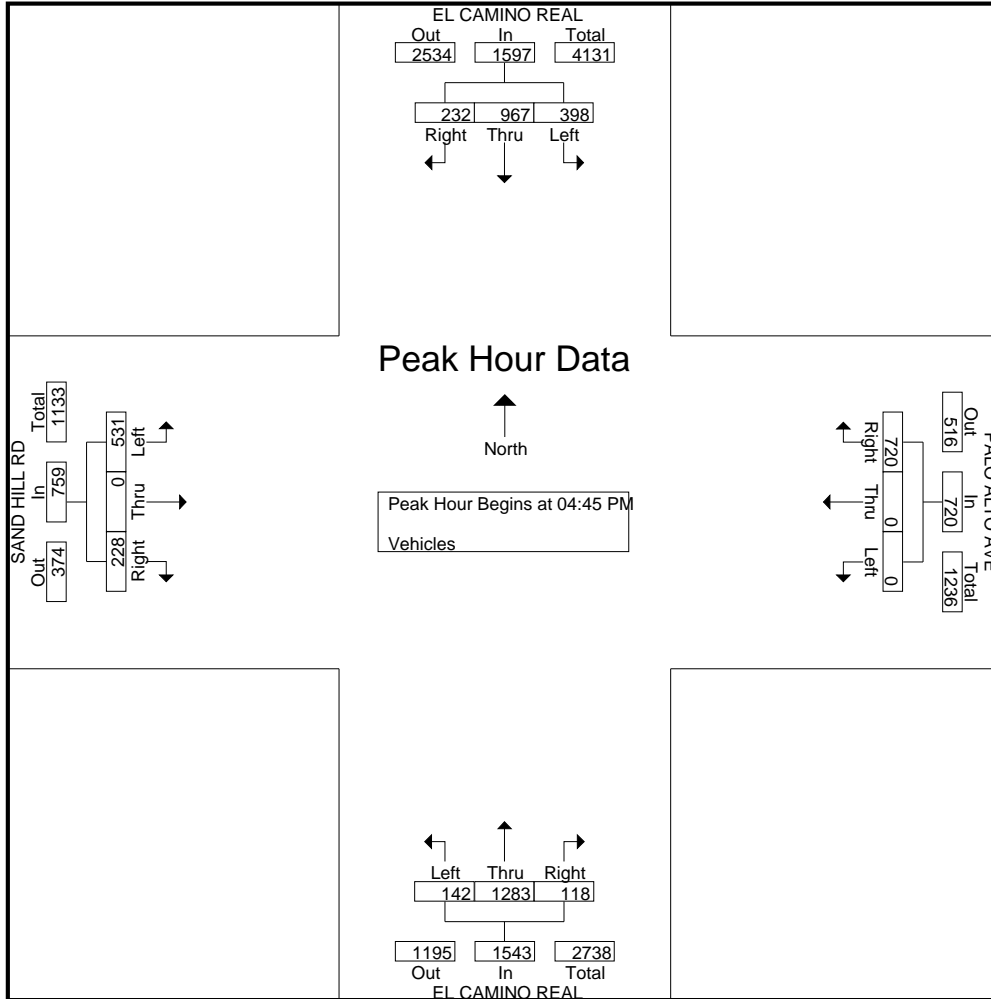

Traffic Data Service

Campbell, CA
(408) 377-2988
tdsbay@cs.com

File Name : 23PM FINAL
Site Code : 00000023
Start Date : 5/22/2013
Page No : 1

Groups Printed- Bikes

Start Time	EL CAMINO REAL Southbound					PALO ALTO AVE Westbound					EL CAMINO REAL Northbound					SAND HILL RD Eastbound					Int. Total
	Right	Thru	Left	Peds	App. Total	Right	Thru	Left	Peds	App. Total	Right	Thru	Left	Peds	App. Total	Right	Thru	Left	Peds	App. Total	
04:00 PM	0	0	0	0	0	1	0	0	0	1	0	1	0	0	1	0	0	0	0	0	2
04:15 PM	0	0	1	0	1	0	0	0	0	0	0	1	0	0	1	0	0	0	0	0	2
04:30 PM	0	0	0	0	0	0	0	0	0	0	1	0	0	0	1	0	0	1	0	1	2
04:45 PM	0	0	0	0	0	0	0	0	0	0	2	1	0	0	3	0	0	0	0	0	3
Total	0	0	1	0	1	1	0	0	0	1	3	3	0	0	6	0	0	1	0	1	9
05:00 PM	0	0	0	0	0	0	0	0	0	0	1	0	0	0	1	0	0	0	0	0	1
05:15 PM	0	0	0	0	0	0	0	0	0	0	0	0	0	0	0	0	0	0	0	0	0
05:30 PM	0	0	0	0	0	0	0	0	0	0	1	0	0	0	1	0	0	0	0	0	1
05:45 PM	0	0	0	0	0	1	0	0	0	1	0	0	0	0	0	0	0	0	0	0	1
Total	0	0	0	0	0	1	0	0	0	1	2	0	0	0	2	0	0	0	0	0	3
Grand Total	0	0	1	0	1	2	0	0	0	2	5	3	0	0	8	0	0	1	0	1	12
Apprch %	0	0	100	0		100	0	0	0		62.5	37.5	0	0		0	0	100	0		
Total %	0	0	8.3	0	8.3	16.7	0	0	0	16.7	41.7	25	0	0	66.7	0	0	8.3	0	8.3	

Start Time	EL CAMINO REAL Southbound				PALO ALTO AVE Westbound				EL CAMINO REAL Northbound				SAND HILL RD Eastbound				Int. Total
	Right	Thru	Left	App. Total	Right	Thru	Left	App. Total	Right	Thru	Left	App. Total	Right	Thru	Left	App. Total	
Peak Hour Analysis From 04:00 PM to 05:45 PM - Peak 1 of 1																	
Peak Hour for Entire Intersection Begins at 04:00 PM																	
04:00 PM	0	0	0	0	1	0	0	1	0	1	0	1	0	0	0	0	2
04:15 PM	0	0	1	1	0	0	0	0	0	1	0	1	0	0	0	0	2
04:30 PM	0	0	0	0	0	0	0	0	1	0	0	1	0	0	1	1	2
04:45 PM	0	0	0	0	0	0	0	0	2	1	0	3	0	0	0	0	3
Total Volume	0	0	1	1	1	0	0	1	3	3	0	6	0	0	1	1	9
% App. Total	0	0	100		100	0	0		50	50	0		0	0	100		
PHF	.000	.000	.250	.250	.250	.000	.000	.250	.375	.750	.000	.500	.000	.000	.250	.250	.750

Traffic Data Service

Campbell, CA

(408) 377-2988

tdsbay@cs.com

File Name : 23PM FINAL

Site Code : 00000023

Start Date : 5/22/2013

Page No : 2

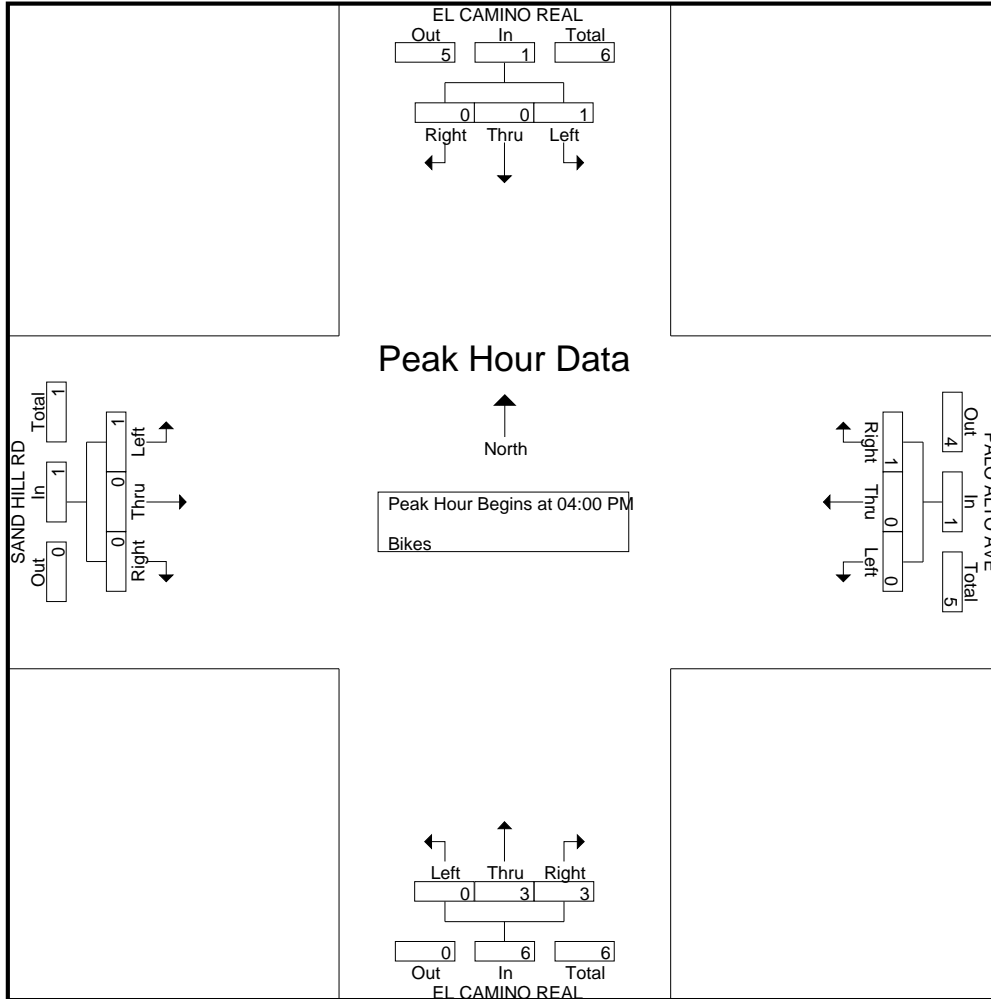

Traffic Data Service

Campbell, CA
 (408) 377-2988
 tdsbay@cs.com

File Name : 84AM FINAL
 Site Code : 00000084
 Start Date : 6/4/2013
 Page No : 1

Groups Printed- Vehicles

Start Time	HIGH ST Southbound					UNIVERSITY AVE Westbound					HIGH ST Northbound					UNIVERSITY AVE Eastbound					Int. Total
	Right	Thru	Left	Peds	App. Total	Right	Thru	Left	Peds	App. Total	Right	Thru	Left	Peds	App. Total	Right	Thru	Left	Peds	App. Total	
07:00 AM	37	4	1	19	61	0	113	5	7	125	0	0	0	14	14	16	63	0	6	85	285
07:15 AM	45	0	1	23	69	0	113	6	7	126	0	0	0	12	12	16	81	0	5	102	309
07:30 AM	49	7	1	28	85	0	109	5	9	123	0	0	0	19	19	33	99	0	16	148	375
07:45 AM	50	7	2	41	100	0	159	5	14	178	0	0	0	24	24	45	115	0	16	176	478
Total	181	18	5	111	315	0	494	21	37	552	0	0	0	69	69	110	358	0	43	511	1447
08:00 AM	54	6	3	45	108	0	130	4	10	144	0	0	0	28	28	50	101	0	22	173	453
08:15 AM	54	7	2	38	101	0	133	2	8	143	0	0	0	28	28	64	123	0	20	207	479
08:30 AM	57	8	4	63	132	0	113	0	16	129	0	0	0	29	29	56	112	0	41	209	499
08:45 AM	53	11	1	78	143	0	141	1	23	165	0	0	0	40	40	58	105	0	46	209	557
Total	218	32	10	224	484	0	517	7	57	581	0	0	0	125	125	228	441	0	129	798	1988
Grand Total	399	50	15	335	799	0	1011	28	94	1133	0	0	0	194	194	338	799	0	172	1309	3435
Apprch %	49.9	6.3	1.9	41.9		0	89.2	2.5	8.3		0	0	0	100		25.8	61	0	13.1		
Total %	11.6	1.5	0.4	9.8	23.3	0	29.4	0.8	2.7	33	0	0	0	5.6	5.6	9.8	23.3	0	5	38.1	

Start Time	HIGH ST Southbound					UNIVERSITY AVE Westbound					HIGH ST Northbound					UNIVERSITY AVE Eastbound					Int. Total
	Right	Thru	Left	Peds	App. Total	Right	Thru	Left	Peds	App. Total	Right	Thru	Left	Peds	App. Total	Right	Thru	Left	Peds	App. Total	
07:45 AM	50	7	2		59	0	159	5	164		0	0	0	0		45	115	0		160	383
08:00 AM	54	6	3		63	0	130	4		134	0	0	0	0		50	101	0		151	348
08:15 AM	54	7	2		63	0	133	2		135	0	0	0	0		64	123	0		187	385
08:30 AM	57	8	4		69	0	113	0		113	0	0	0	0		56	112	0		168	350
Total Volume	215	28	11		254	0	535	11		546	0	0	0	0		215	451	0		666	1466
% App. Total	84.6	11	4.3			0	98	2			0	0	0	0		32.3	67.7	0			
PHF	.943	.875	.688		.920	.000	.841	.550		.832	.000	.000	.000	.000		.840	.917	.000		.890	.952

Peak Hour Analysis From 07:00 AM to 08:45 AM - Peak 1 of 1

Peak Hour for Entire Intersection Begins at 07:45 AM

Traffic Data Service

Campbell, CA
(408) 377-2988
tdsbay@cs.com

File Name : 84AM FINAL
Site Code : 00000084
Start Date : 6/4/2013
Page No : 2

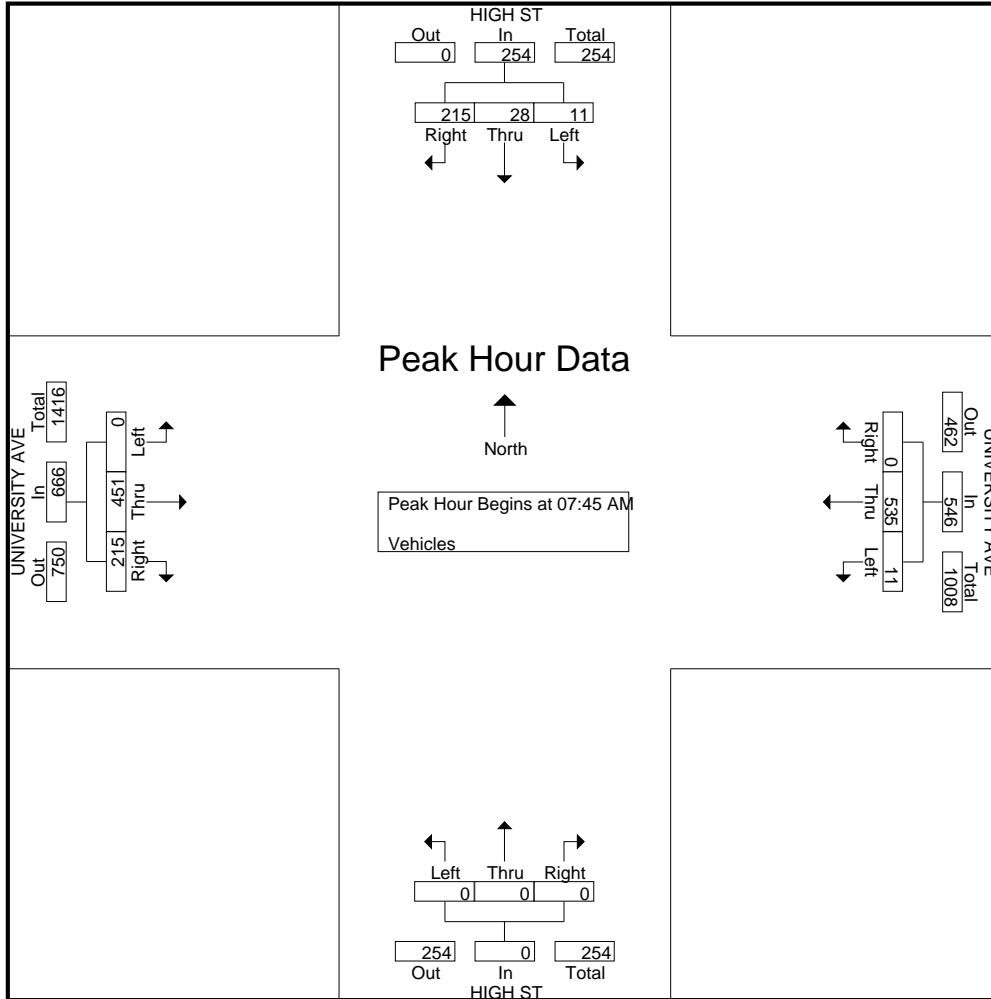

Traffic Data Service

Campbell, CA
 (408) 377-2988
 tdsbay@cs.com

File Name : 84AM FINAL
 Site Code : 00000084
 Start Date : 6/4/2013
 Page No : 1

Groups Printed- Bikes

Start Time	HIGH ST Southbound					UNIVERSITY AVE Westbound					HIGH ST Northbound					UNIVERSITY AVE Eastbound					Int. Total
	Right	Thru	Left	Peds	App. Total	Right	Thru	Left	Peds	App. Total	Right	Thru	Left	Peds	App. Total	Right	Thru	Left	Peds	App. Total	
07:00 AM	3	0	0	0	3	0	0	0	0	0	0	0	0	0	0	0	2	0	0	2	5
07:15 AM	3	0	0	0	3	0	10	0	0	10	0	0	0	0	0	0	0	0	0	0	13
07:30 AM	4	0	0	0	4	0	8	0	0	8	0	0	0	0	0	0	0	0	0	0	12
07:45 AM	8	4	0	0	12	0	11	0	0	11	0	0	0	0	0	2	1	0	0	3	26
Total	18	4	0	0	22	0	29	0	0	29	0	0	0	0	0	2	3	0	0	5	56
08:00 AM	6	0	0	0	6	0	7	0	0	7	0	0	0	0	0	0	1	0	0	1	14
08:15 AM	8	1	0	0	9	0	9	0	0	9	0	0	0	0	0	0	3	0	0	3	21
08:30 AM	7	0	0	0	7	0	10	0	0	10	0	0	0	0	0	1	0	0	0	1	18
08:45 AM	7	3	0	0	10	0	11	0	0	11	0	0	0	0	0	1	0	0	0	1	22
Total	28	4	0	0	32	0	37	0	0	37	0	0	0	0	0	2	4	0	0	6	75
Grand Total	46	8	0	0	54	0	66	0	0	66	0	0	0	0	0	4	7	0	0	11	131
Apprch %	85.2	14.8	0	0		0	100	0	0		0	0	0	0		36.4	63.6	0	0		
Total %	35.1	6.1	0	0	41.2	0	50.4	0	0	50.4	0	0	0	0	0	3.1	5.3	0	0	8.4	

Start Time	HIGH ST Southbound					UNIVERSITY AVE Westbound					HIGH ST Northbound					UNIVERSITY AVE Eastbound					Int. Total
	Right	Thru	Left	Peds	App. Total	Right	Thru	Left	Peds	App. Total	Right	Thru	Left	Peds	App. Total	Right	Thru	Left	Peds	App. Total	
07:45 AM	8	4	0	0	12	0	11	0	0	11	0	0	0	0	0	2	1	0	0	3	26
08:00 AM	6	0	0	0	6	0	7	0	0	7	0	0	0	0	0	0	1	0	0	1	14
08:15 AM	8	1	0	0	9	0	9	0	0	9	0	0	0	0	0	0	3	0	0	3	21
08:30 AM	7	0	0	0	7	0	10	0	0	10	0	0	0	0	0	1	0	0	0	1	18
Total Volume	29	5	0	0	34	0	37	0	0	37	0	0	0	0	0	3	5	0	0	8	79
% App. Total	85.3	14.7	0	0		0	100	0	0		0	0	0	0		37.5	62.5	0	0		
PHF	.906	.313	.000	.000	.708	.000	.841	.000	.000	.841	.000	.000	.000	.000	.000	.375	.417	.000	.000	.667	.760

Peak Hour Analysis From 07:00 AM to 08:45 AM - Peak 1 of 1

Peak Hour for Entire Intersection Begins at 07:45 AM

Traffic Data Service

Campbell, CA
 (408) 377-2988
 tdsbay@cs.com

File Name : 84AM FINAL
 Site Code : 00000084
 Start Date : 6/4/2013
 Page No : 2

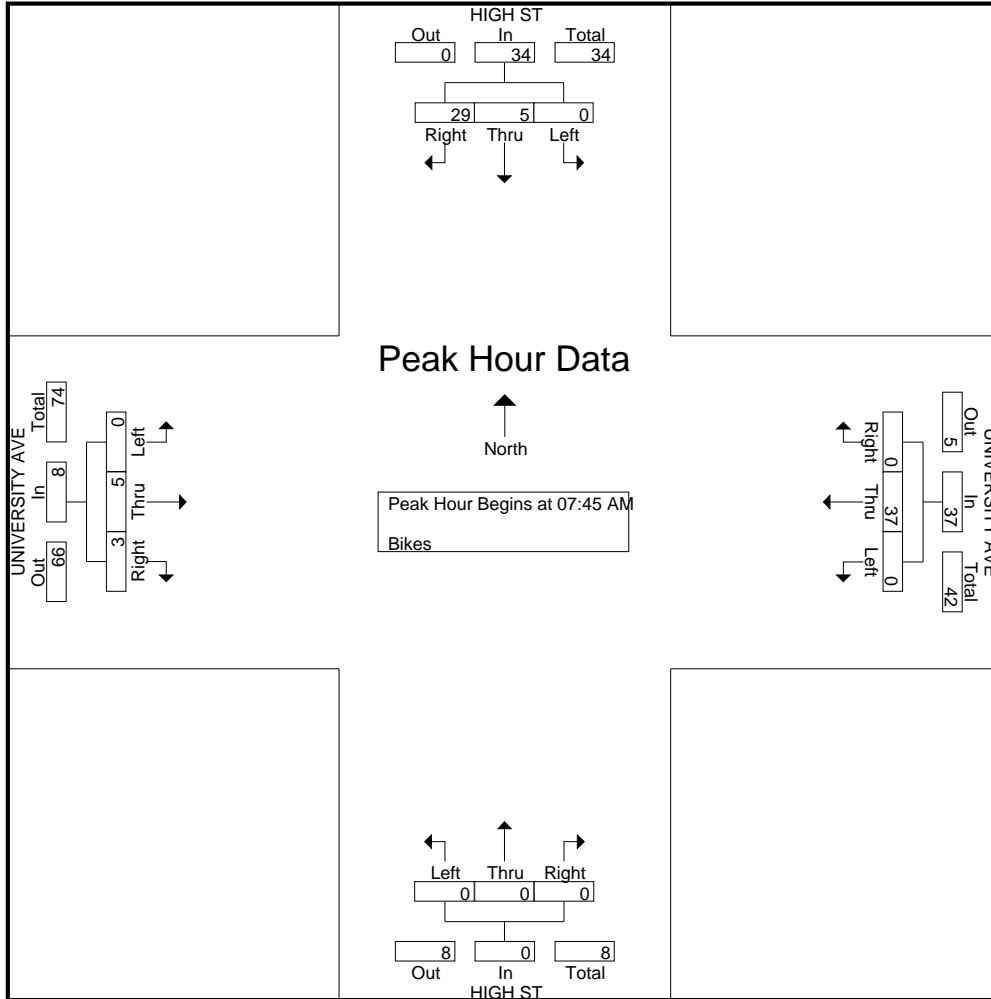

Traffic Data Service

Campbell, CA
 (408) 377-2988
 tdsbay@cs.com

File Name : 84PM FINAL
 Site Code : 00000084
 Start Date : 6/4/2013
 Page No : 1

Groups Printed- Vehicles

Start Time	HIGH ST Southbound					UNIVERSITY AVE Westbound					HIGH ST Northbound					UNIVERSITY AVE Eastbound					Int. Total
	Right	Thru	Left	Peds	App. Total	Right	Thru	Left	Peds	App. Total	Right	Thru	Left	Peds	App. Total	Right	Thru	Left	Peds	App. Total	
04:00 PM	41	6	1	55	103	0	126	7	39	172	0	0	0	33	33	84	137	0	18	239	547
04:15 PM	38	16	0	42	96	0	125	8	38	171	0	0	0	45	45	97	140	0	28	265	577
04:30 PM	36	17	0	48	101	0	90	0	30	120	0	0	0	41	41	83	150	0	29	262	524
04:45 PM	38	13	1	50	102	0	111	5	32	148	0	0	0	46	46	79	145	0	34	258	554
Total	153	52	2	195	402	0	452	20	139	611	0	0	0	165	165	343	572	0	109	1024	2202
05:00 PM	42	15	2	76	135	0	108	7	31	146	0	0	0	48	48	89	150	0	30	269	598
05:15 PM	37	16	3	48	104	0	100	7	20	127	0	0	0	56	56	105	158	0	24	287	574
05:30 PM	36	20	5	71	132	0	104	4	37	145	0	0	0	63	63	105	139	0	26	270	610
05:45 PM	40	14	4	78	136	0	97	9	47	153	0	0	0	79	79	97	140	0	32	269	637
Total	155	65	14	273	507	0	409	27	135	571	0	0	0	246	246	396	587	0	112	1095	2419
Grand Total	308	117	16	468	909	0	861	47	274	1182	0	0	0	411	411	739	1159	0	221	2119	4621
Apprch %	33.9	12.9	1.8	51.5		0	72.8	4	23.2		0	0	0	100		34.9	54.7	0	10.4		
Total %	6.7	2.5	0.3	10.1	19.7	0	18.6	1	5.9	25.6	0	0	0	8.9	8.9	16	25.1	0	4.8	45.9	

Start Time	HIGH ST Southbound				UNIVERSITY AVE Westbound				HIGH ST Northbound				UNIVERSITY AVE Eastbound				Int. Total
	Right	Thru	Left	App. Total	Right	Thru	Left	App. Total	Right	Thru	Left	App. Total	Right	Thru	Left	App. Total	
05:00 PM	42	15	2	59	0	108	7	115	0	0	0	0	89	150	0	239	413
05:15 PM	37	16	3	56	0	100	7	107	0	0	0	0	105	158	0	263	426
05:30 PM	36	20	5	61	0	104	4	108	0	0	0	0	105	139	0	244	413
05:45 PM	40	14	4	58	0	97	9	106	0	0	0	0	97	140	0	237	401
Total Volume	155	65	14	234	0	409	27	436	0	0	0	0	396	587	0	983	1653
% App. Total	66.2	27.8	6		0	93.8	6.2		0	0	0		40.3	59.7	0		
PHF	.923	.813	.700	.959	.000	.947	.750	.948	.000	.000	.000	.000	.943	.929	.000	.934	.970

Peak Hour Analysis From 04:00 PM to 05:45 PM - Peak 1 of 1

Peak Hour for Entire Intersection Begins at 05:00 PM

Traffic Data Service

Campbell, CA
 (408) 377-2988
 tdsbay@cs.com

File Name : 84PM FINAL
 Site Code : 00000084
 Start Date : 6/4/2013
 Page No : 2

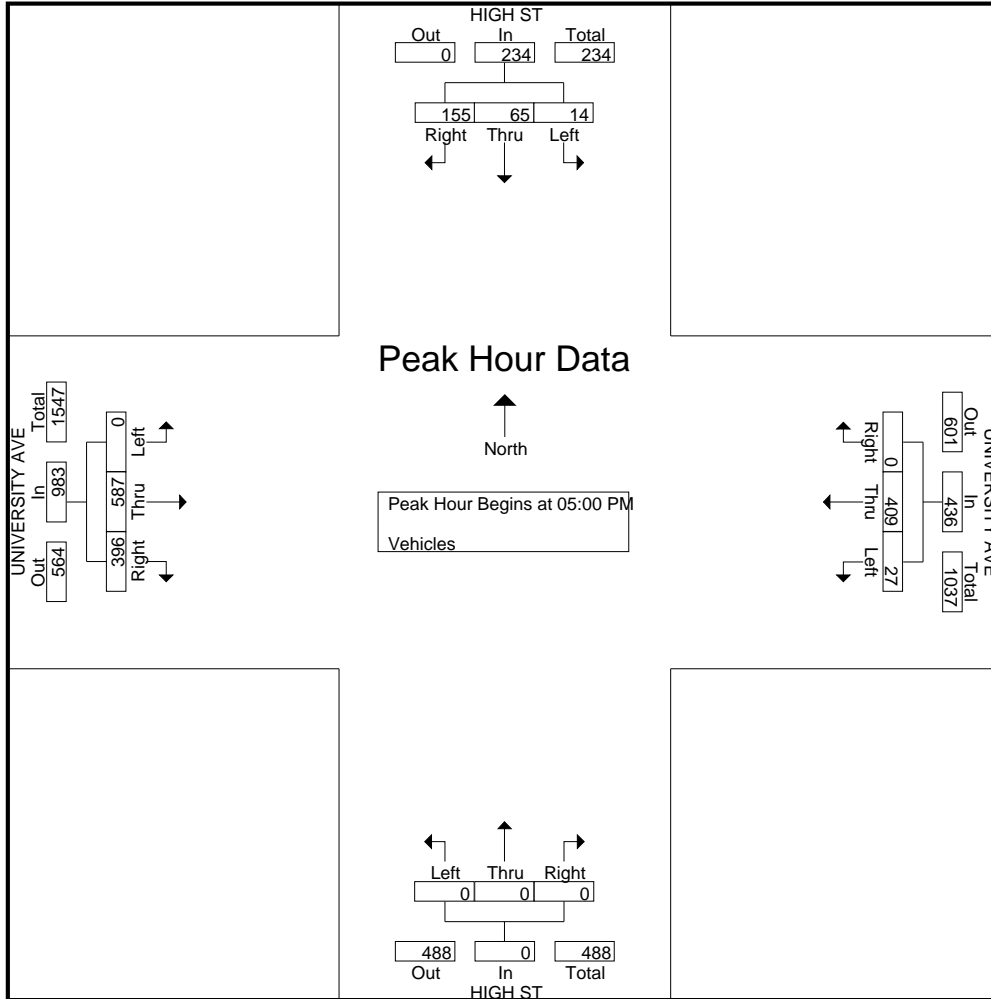

Traffic Data Service

Campbell, CA
 (408) 377-2988
 tdsbay@cs.com

File Name : 84PM FINAL
 Site Code : 00000084
 Start Date : 6/4/2013
 Page No : 1

Groups Printed- Bikes

Start Time	HIGH ST Southbound					UNIVERSITY AVE Westbound					HIGH ST Northbound					UNIVERSITY AVE Eastbound					Int. Total
	Right	Thru	Left	Peds	App. Total	Right	Thru	Left	Peds	App. Total	Right	Thru	Left	Peds	App. Total	Right	Thru	Left	Peds	App. Total	
04:00 PM	2	0	0	0	2	0	6	0	0	6	0	0	0	0	0	0	6	0	0	6	14
04:15 PM	2	0	0	0	2	0	6	0	0	6	0	0	0	0	0	0	5	0	0	5	13
04:30 PM	1	0	0	0	1	0	5	0	0	5	0	0	0	0	0	1	7	0	0	8	14
04:45 PM	0	0	0	0	0	0	7	0	0	7	0	0	0	0	0	0	7	0	0	7	14
Total	5	0	0	0	5	0	24	0	0	24	0	0	0	0	0	1	25	0	0	26	55
05:00 PM	3	1	1	0	5	0	3	0	0	3	0	0	0	0	0	2	9	0	0	11	19
05:15 PM	0	2	0	0	2	0	7	0	0	7	0	0	0	0	0	2	13	0	0	15	24
05:30 PM	0	1	0	0	1	0	4	0	0	4	0	0	0	0	0	2	7	0	0	9	14
05:45 PM	0	1	0	0	1	0	10	0	0	10	0	0	0	0	0	3	12	0	0	15	26
Total	3	5	1	0	9	0	24	0	0	24	0	0	0	0	0	9	41	0	0	50	83
Grand Total	8	5	1	0	14	0	48	0	0	48	0	0	0	0	0	10	66	0	0	76	138
Apprch %	57.1	35.7	7.1	0		0	100	0	0		0	0	0	0		13.2	86.8	0	0		
Total %	5.8	3.6	0.7	0	10.1	0	34.8	0	0	34.8	0	0	0	0	0	7.2	47.8	0	0	55.1	

Start Time	HIGH ST Southbound				UNIVERSITY AVE Westbound				HIGH ST Northbound				UNIVERSITY AVE Eastbound				Int. Total
	Right	Thru	Left	App. Total	Right	Thru	Left	App. Total	Right	Thru	Left	App. Total	Right	Thru	Left	App. Total	
05:00 PM	3	1	1	5	0	3	0	3	0	0	0	0	2	9	0	11	19
05:15 PM	0	2	0	2	0	7	0	7	0	0	0	0	2	13	0	15	24
05:30 PM	0	1	0	1	0	4	0	4	0	0	0	0	2	7	0	9	14
05:45 PM	0	1	0	1	0	10	0	10	0	0	0	0	3	12	0	15	26
Total Volume	3	5	1	9	0	24	0	24	0	0	0	0	9	41	0	50	83
% App. Total	33.3	55.6	11.1		0	100	0		0	0	0		18	82	0		
PHF	.250	.625	.250	.450	.000	.600	.000	.600	.000	.000	.000	.000	.750	.788	.000	.833	.798

Peak Hour Analysis From 04:00 PM to 05:45 PM - Peak 1 of 1

Peak Hour for Entire Intersection Begins at 05:00 PM

Traffic Data Service

Campbell, CA
(408) 377-2988
tdsbay@cs.com

File Name : 84PM FINAL
Site Code : 00000084
Start Date : 6/4/2013
Page No : 2

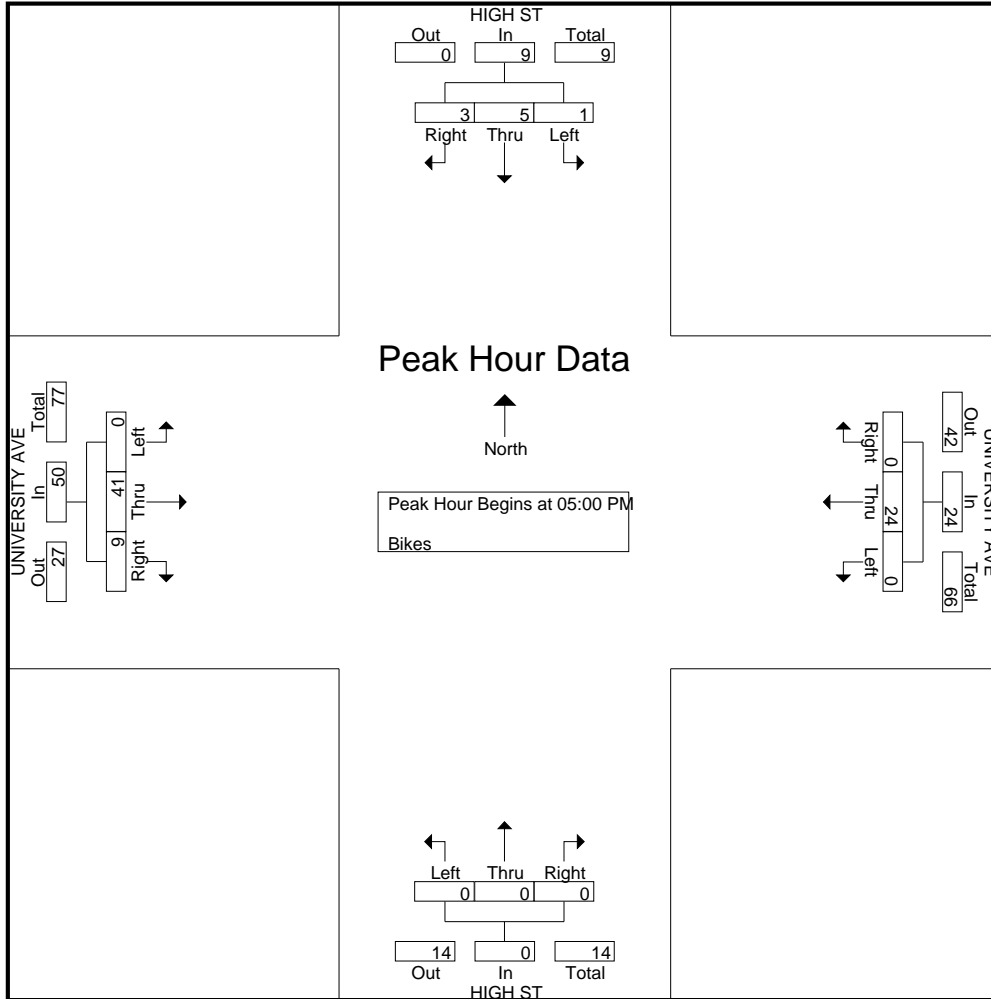

MARKS TRAFFIC DATA

mietekm@comcast.net
916.806.0250

CITY OF PALO ALTO
ALMA ST. - EMBARCADERO RD. to CHURCHILL ST.

Site Code: 10
alma10-n class

NORTHBOUND

Start Time	Bikes	Cars & Trailers	2 Axle Long	Buses	2 Axle 6 Tire	3 Axle Single	4 Axle Single	<5 Axl Double	5 Axle Double	>6 Axl Double	<6 Axl Multi	6 Axle Multi	>6 Axl Multi	Not Classed	Total
04/16/13	1	29	1	0	0	0	0	0	0	0	0	0	0	1	32
01:00	2	7	0	0	1	0	0	0	0	0	0	0	0	1	11
02:00	0	7	1	0	0	0	0	1	0	0	0	0	0	0	9
03:00	1	7	1	0	0	0	0	0	0	0	0	0	0	2	11
04:00	0	17	3	1	2	0	0	0	1	0	0	0	0	1	25
05:00	2	95	12	0	1	0	0	1	0	0	0	0	0	2	113
06:00	8	257	31	3	4	4	0	2	1	0	0	0	0	12	322
07:00	31	607	54	4	10	4	0	9	3	0	0	0	2	41	765
08:00	63	740	42	8	10	17	0	15	1	4	3	0	3	119	1025
09:00	68	712	51	6	10	9	4	10	2	2	1	0	1	98	974
10:00	16	620	45	0	13	5	0	11	1	1	0	1	0	30	743
11:00	6	560	54	1	7	8	1	6	2	2	0	0	0	12	659
12 PM	13	596	55	0	6	7	0	10	0	0	1	1	0	13	702
13:00	13	536	56	1	6	3	0	10	0	0	0	0	1	9	635
14:00	10	509	50	1	8	6	0	5	1	2	1	0	0	13	606
15:00	7	653	60	0	7	9	0	11	0	1	2	0	1	30	781
16:00	5	705	44	0	8	11	1	7	3	0	0	0	0	38	822
17:00	18	848	34	2	9	8	0	7	2	4	1	0	1	37	971
18:00	16	842	35	0	3	22	1	3	1	1	0	0	0	31	955
19:00	10	559	25	0	1	4	0	2	2	1	0	0	1	15	620
20:00	11	334	24	0	0	2	0	1	0	0	0	0	0	9	381
21:00	6	248	11	0	0	1	0	0	1	0	0	0	0	5	272
22:00	4	139	8	0	2	0	0	0	0	0	0	0	0	2	155
23:00	1	54	8	0	1	0	0	0	0	0	0	0	0	1	65
Total	312	9681	705	27	109	120	7	111	21	18	9	2	10	522	11654
Percent	2.7%	83.1%	6.0%	0.2%	0.9%	1.0%	0.1%	1.0%	0.2%	0.2%	0.1%	0.0%	0.1%	4.5%	
AM Peak	09:00	08:00	07:00	08:00	10:00	08:00	09:00	08:00	07:00	08:00	08:00	10:00	08:00	08:00	
Vol.	68	740	54	8	13	17	4	15	3	4	3	1	3	119	
PM Peak	17:00	17:00	15:00	17:00	17:00	18:00	16:00	15:00	16:00	17:00	15:00	12:00	13:00	16:00	
Vol.	18	848	60	2	9	22	1	11	3	4	2	1	1	38	

Source: Rafael Rius, City of Palo Alto, (650) 329-2305, rafael.rius@cityofpaloalto.org. Transmitted 9/26/13.

MARKS TRAFFIC DATA

mietekm@comcast.net
916.806.0250

CITY OF PALO ALTO
ALMA ST. - EMBARCADERO RD. to CHURCHILL ST.

Site Code: 10
alma10-n class

NORTHBOUND

Start Time	Bikes	Cars & Trailers	2 Axle Long	Buses	2 Axle 6 Tire	3 Axle Single	4 Axle Single	<5 Axl Double	5 Axle Double	>6 Axl Double	<6 Axl Multi	6 Axle Multi	>6 Axl Multi	Not Classed	Total
04/17/13	2	19	1	0	0	0	0	0	0	0	0	0	0	2	24
01:00	0	14	0	0	0	0	0	0	0	0	0	0	0	0	14
02:00	1	9	0	0	0	0	0	0	0	0	0	0	0	1	11
03:00	0	6	2	0	0	0	0	0	0	0	0	0	0	1	9
04:00	1	18	1	0	4	0	0	0	0	0	0	0	0	2	26
05:00	2	87	10	1	3	0	0	2	1	0	0	0	0	2	108
06:00	2	266	26	2	5	0	0	1	0	0	0	0	0	1	303
07:00	16	724	76	5	10	10	1	8	1	0	0	1	2	26	880
08:00	45	940	48	2	8	12	1	12	2	1	1	0	3	74	1149
09:00	27	825	41	3	10	13	0	8	1	1	0	0	2	45	976
10:00	11	658	54	2	7	5	0	5	3	3	1	0	1	39	789
11:00	7	602	40	0	5	7	0	6	0	1	5	0	2	15	690
12 PM	31	519	47	4	8	7	1	3	0	1	0	0	0	48	669
13:00	4	559	64	0	8	7	1	5	1	0	3	0	2	11	665
14:00	7	612	48	1	7	5	0	5	3	0	1	1	0	20	710
15:00	15	624	64	0	2	8	0	4	2	0	0	0	0	22	741
16:00	12	722	46	2	8	8	0	8	0	0	0	0	0	22	828
17:00	14	851	43	0	9	8	1	8	2	3	1	0	0	29	969
18:00	25	802	34	2	4	10	0	8	1	1	1	2	0	37	927
19:00	14	557	40	0	1	7	0	2	0	1	0	0	1	14	637
20:00	6	343	21	0	0	1	0	1	1	1	0	0	0	4	378
21:00	3	238	9	0	0	3	0	0	0	0	0	0	0	5	258
22:00	0	178	6	0	0	0	0	1	0	0	0	0	0	1	186
23:00	1	66	10	0	0	0	0	0	0	0	0	0	0	0	77
Total	246	10239	731	24	99	111	5	87	18	13	13	4	13	421	12024
Percent	2.0%	85.2%	6.1%	0.2%	0.8%	0.9%	0.0%	0.7%	0.1%	0.1%	0.1%	0.0%	0.1%	3.5%	
AM Peak	08:00	08:00	07:00	07:00	07:00	09:00	07:00	08:00	10:00	10:00	11:00	07:00	08:00	08:00	
Vol.	45	940	76	5	10	13	1	12	3	3	5	1	3	74	
PM Peak	12:00	17:00	13:00	12:00	17:00	18:00	12:00	16:00	14:00	17:00	13:00	18:00	13:00	12:00	
Vol.	31	851	64	4	9	10	1	8	3	3	3	2	2	48	

MARKS TRAFFIC DATA

mietekm@comcast.net
916.806.0250

CITY OF PALO ALTO
ALMA ST. - EMBARCADERO RD. to CHURCHILL ST.

Site Code: 10
alma10-n class

NORTHBOUND

Start Time	Bikes	Cars & Trailers	2 Axle Long	Buses	2 Axle 6 Tire	3 Axle Single	4 Axle Single	<5 Axl Double	5 Axle Double	>6 Axl Double	<6 Axl Multi	6 Axle Multi	>6 Axl Multi	Not Classed	Total
04/18/13	0	29	1	0	0	0	0	0	0	0	0	0	0	0	30
01:00	0	18	0	0	0	0	0	0	0	0	0	0	0	0	18
02:00	0	10	1	0	0	0	0	0	0	0	0	0	0	0	11
03:00	1	7	1	0	0	0	0	0	0	0	0	0	0	2	11
04:00	1	23	6	0	3	0	0	1	1	0	0	0	0	1	36
05:00	0	96	9	2	1	1	0	0	0	0	0	0	0	1	110
06:00	4	254	30	2	13	0	0	5	0	0	0	0	1	4	313
07:00	4	649	52	2	6	10	0	6	1	2	2	0	2	16	752
08:00	26	932	53	5	10	14	0	16	1	0	3	0	2	62	1124
09:00	27	827	61	2	13	12	1	3	1	2	1	0	1	59	1010
10:00	10	666	65	2	5	10	0	6	2	0	2	0	1	21	790
11:00	13	599	55	2	7	5	1	11	3	0	2	0	0	19	717
12 PM	9	616	45	3	6	3	1	4	1	0	0	0	1	11	700
13:00	2	549	55	0	7	5	0	7	1	0	0	0	0	18	644
14:00	6	572	55	0	4	2	0	7	1	2	0	0	0	11	660
15:00	12	689	59	2	3	8	1	8	1	1	1	1	0	25	811
16:00	6	717	47	2	8	6	0	2	1	3	1	0	0	25	818
17:00	10	928	45	3	8	13	1	4	0	1	2	1	2	32	1050
18:00	10	893	35	1	2	17	1	9	1	0	0	0	1	38	1008
19:00	9	557	28	1	3	7	1	1	0	0	0	0	0	23	630
20:00	8	332	21	0	0	2	1	3	0	0	0	0	0	9	376
21:00	7	258	8	0	0	0	0	1	0	0	0	0	0	3	277
22:00	2	163	11	0	0	0	0	0	0	0	0	0	0	0	176
23:00	3	85	8	0	0	0	0	0	0	0	0	0	0	4	100
Total	170	10469	751	29	99	115	8	94	15	11	14	2	11	384	12172
Percent	1.4%	86.0%	6.2%	0.2%	0.8%	0.9%	0.1%	0.8%	0.1%	0.1%	0.1%	0.0%	0.1%	3.2%	
AM Peak	09:00	08:00	10:00	08:00	06:00	08:00	09:00	08:00	11:00	07:00	08:00		07:00	08:00	
Vol.	27	932	65	5	13	14	1	16	3	2	3		2	62	
PM Peak	15:00	17:00	15:00	12:00	16:00	18:00	12:00	18:00	12:00	16:00	17:00	15:00	17:00	18:00	
Vol.	12	928	59	3	8	17	1	9	1	3	2	1	2	38	
Grand Total	728	30389	2187	80	307	346	20	292	54	42	36	8	34	1327	35850
Percent	2.0%	84.8%	6.1%	0.2%	0.9%	1.0%	0.1%	0.8%	0.2%	0.1%	0.1%	0.0%	0.1%	3.7%	

MARKS TRAFFIC DATA

mietekm@comcast.net
916.806.0250

CITY OF PALO ALTO
ALMA ST. - EMBARCADERO RD. to CHURCHILL

Site Code: 10
alma10-s class

SOUTHBOUND

Start Time	Bikes	Cars & Trailers	2 Axle Long	Buses	2 Axle 6 Tire	3 Axle Single	4 Axle Single	<5 Axl Double	5 Axle Double	>6 Axl Double	<6 Axl Multi	6 Axle Multi	>6 Axl Multi	Not Classed	Total
04/16/13	0	71	1	0	0	0	0	0	0	0	0	0	0	0	72
01:00	1	28	0	0	0	1	0	0	0	0	0	0	0	1	31
02:00	0	9	0	0	1	0	0	0	0	0	0	0	0	0	10
03:00	0	10	1	0	0	0	0	0	0	0	0	0	0	0	11
04:00	0	13	1	0	1	0	0	0	0	0	0	0	0	0	15
05:00	0	46	3	1	1	1	0	1	2	0	0	0	0	1	56
06:00	2	101	12	0	3	0	0	0	0	0	0	0	0	2	120
07:00	10	350	34	1	9	4	0	3	0	0	0	0	0	21	432
08:00	12	562	57	2	13	10	0	4	0	0	0	0	0	44	704
09:00	8	493	36	4	13	1	0	1	0	0	0	0	0	19	575
10:00	3	401	47	1	8	5	0	1	1	0	0	0	0	12	479
11:00	3	481	44	3	7	5	0	2	1	0	0	0	0	9	555
12 PM	11	532	55	0	11	8	0	1	0	0	0	0	0	23	641
13:00	6	602	57	1	13	6	0	2	0	1	0	0	0	19	707
14:00	16	659	50	0	9	16	0	6	1	0	0	0	0	37	794
15:00	7	659	63	1	9	15	1	1	0	0	0	0	0	46	802
16:00	31	851	50	2	6	14	2	5	2	0	0	0	0	99	1062
17:00	22	986	65	2	7	21	0	4	0	0	0	0	0	152	1259
18:00	10	907	38	1	6	23	0	0	1	0	0	0	0	64	1050
19:00	9	666	24	1	3	13	0	0	0	0	0	0	0	33	749
20:00	6	497	24	0	0	6	0	0	0	0	0	0	0	23	556
21:00	5	485	14	2	1	4	0	0	0	1	0	0	0	18	530
22:00	4	345	13	0	1	1	0	0	1	0	0	0	0	10	375
23:00	5	159	9	0	2	2	0	0	0	0	0	0	0	3	180
Total	171	9913	698	22	124	156	3	31	9	2	0	0	0	636	11765
Percent	1.5%	84.3%	5.9%	0.2%	1.1%	1.3%	0.0%	0.3%	0.1%	0.0%	0.0%	0.0%	0.0%	5.4%	
AM Peak	08:00	08:00	08:00	09:00	08:00	08:00		08:00	05:00					08:00	
Vol.	12	562	57	4	13	10		4	2					44	
PM Peak	16:00	17:00	17:00	16:00	13:00	18:00	16:00	14:00	16:00	13:00				17:00	
Vol.	31	986	65	2	13	23	2	6	2	1				152	

Source: Rafael Rius, City of Palo Alto, (650) 329-2305, rafael.rius@cityofpaloalto.org. Transmitted 9/26/13.

MARKS TRAFFIC DATA

mietekm@comcast.net
916.806.0250

CITY OF PALO ALTO
ALMA ST. - EMBARCADERO RD. to CHURCHILL

Site Code: 10
alma10-s class

SOUTHBOUND

Start Time	Bikes	Cars & Trailers	2 Axle Long	Buses	2 Axle 6 Tire	3 Axle Single	4 Axle Single	<5 Axl Double	5 Axle Double	>6 Axl Double	<6 Axl Multi	6 Axle Multi	>6 Axl Multi	Not Classed	Total
04/17/13	2	77	2	0	0	0	0	0	0	0	0	0	0	1	82
01:00	1	36	2	0	0	0	0	0	0	0	0	0	0	0	39
02:00	0	15	2	0	0	0	0	1	0	0	0	0	0	0	18
03:00	0	3	1	0	0	0	0	0	0	0	0	0	0	0	4
04:00	0	9	0	1	2	0	0	0	0	0	0	0	0	0	12
05:00	0	41	6	0	1	0	1	1	0	0	0	0	0	0	50
06:00	1	101	15	1	5	1	0	1	2	0	0	0	0	4	131
07:00	6	354	24	2	10	4	0	1	1	0	0	0	0	12	414
08:00	12	601	61	3	12	5	0	2	0	0	0	0	0	36	732
09:00	7	446	35	3	12	8	0	3	0	0	0	0	0	18	532
10:00	4	435	49	1	13	3	0	2	0	0	0	1	0	12	520
11:00	7	499	51	1	11	7	0	1	1	0	0	0	0	17	595
12 PM	7	568	48	1	4	11	0	6	0	0	0	0	0	29	674
13:00	5	621	46	1	10	9	0	3	0	0	1	0	0	24	720
14:00	8	738	52	3	9	4	2	2	2	0	0	0	0	25	845
15:00	13	810	72	2	8	9	0	2	0	0	0	0	0	32	948
16:00	13	890	65	1	8	13	0	3	2	0	1	0	0	81	1077
17:00	27	1023	52	2	9	13	0	2	1	0	0	0	1	112	1242
18:00	15	938	30	1	7	12	0	1	0	0	0	0	0	60	1064
19:00	6	695	25	0	3	11	0	2	0	0	0	0	0	26	768
20:00	4	548	21	0	0	3	0	2	1	0	0	0	0	15	594
21:00	6	483	18	0	1	5	0	2	0	0	0	0	0	16	531
22:00	9	341	19	1	1	6	0	1	0	0	0	0	0	19	397
23:00	3	176	14	0	1	0	0	0	0	0	0	0	0	3	197
Total	156	10448	710	24	127	124	3	38	10	0	2	1	1	542	12186
Percent	1.3%	85.7%	5.8%	0.2%	1.0%	1.0%	0.0%	0.3%	0.1%	0.0%	0.0%	0.0%	0.0%	4.4%	
AM Peak	08:00	08:00	08:00	08:00	10:00	09:00	05:00	09:00	06:00			10:00		08:00	
Vol.	12	601	61	3	13	8	1	3	2			1		36	
PM Peak	17:00	17:00	15:00	14:00	13:00	16:00	14:00	12:00	14:00		13:00		17:00	17:00	
Vol.	27	1023	72	3	10	13	2	6	2		1		1	112	

MARKS TRAFFIC DATA

mietekm@comcast.net
916.806.0250

CITY OF PALO ALTO
ALMA ST. - EMBARCADERO RD. to CHURCHILL

Site Code: 10
alma10-s class

SOUTHBOUND

Start Time	Bikes	Cars & Trailers	2 Axle Long	Buses	2 Axle 6 Tire	3 Axle Single	4 Axle Single	<5 Axl Double	5 Axle Double	>6 Axl Double	<6 Axl Multi	6 Axle Multi	>6 Axl Multi	Not Classed	Total
04/18/13	1	68	9	0	0	1	0	0	0	0	0	0	0	3	82
01:00	0	39	6	0	0	0	0	0	0	0	0	0	0	0	45
02:00	0	15	1	0	0	0	0	0	0	0	0	0	0	0	16
03:00	0	7	1	0	0	0	0	0	0	0	0	0	0	0	8
04:00	0	8	1	0	0	0	0	0	0	0	0	0	0	0	9
05:00	0	35	6	0	2	1	0	0	1	0	0	0	0	2	47
06:00	0	105	15	1	4	0	0	0	0	0	0	0	0	2	127
07:00	3	346	26	2	13	9	0	3	0	0	0	0	0	28	430
08:00	18	574	53	4	14	6	0	4	0	0	0	0	0	36	709
09:00	3	518	41	2	17	5	0	0	0	0	1	0	0	23	610
10:00	3	467	60	2	6	2	0	3	1	0	0	0	0	17	561
11:00	7	513	59	0	13	8	0	2	0	0	0	0	0	22	624
12 PM	9	597	50	1	10	6	0	1	1	0	0	0	0	25	700
13:00	11	614	62	0	9	4	1	1	1	0	1	0	0	21	725
14:00	12	742	65	4	3	17	0	4	0	0	0	0	0	41	888
15:00	6	775	59	1	13	17	0	6	0	0	0	0	0	42	919
16:00	21	872	57	1	13	23	0	5	1	0	2	1	0	75	1071
17:00	41	920	37	4	7	22	0	3	0	0	0	0	0	134	1168
18:00	9	941	36	1	3	16	0	5	1	0	0	0	0	51	1063
19:00	8	749	18	1	0	6	0	1	0	0	0	0	0	22	805
20:00	9	563	19	0	0	8	0	0	0	0	0	0	0	32	631
21:00	4	534	27	0	3	7	1	0	0	0	0	0	0	23	599
22:00	2	379	20	1	1	5	0	1	1	0	0	0	0	10	420
23:00	1	228	9	0	0	0	0	0	0	0	0	0	0	4	242
Total	168	10609	737	25	131	163	2	39	7	0	4	1	0	613	12499
Percent	1.3%	84.9%	5.9%	0.2%	1.0%	1.3%	0.0%	0.3%	0.1%	0.0%	0.0%	0.0%	0.0%	4.9%	
AM Peak	08:00	08:00	10:00	08:00	09:00	07:00		08:00	05:00		09:00			08:00	
Vol.	18	574	60	4	17	9		4	1		1			36	
PM Peak	17:00	18:00	14:00	14:00	15:00	16:00	13:00	15:00	12:00		16:00	16:00		17:00	
Vol.	41	941	65	4	13	23	1	6	1		2	1		134	
Grand Total	495	30970	2145	71	382	443	8	108	26	2	6	2	1	1791	36450
Percent	1.4%	85.0%	5.9%	0.2%	1.0%	1.2%	0.0%	0.3%	0.1%	0.0%	0.0%	0.0%	0.0%	4.9%	

Traffic Data Service

Campbell, CA
 (408) 377-2988
 tdsbay@cs.com

File Name : 3AMPM FINAL
 Site Code : 00000003
 Start Date : 11/2/2011
 Page No : 1

Groups Printed- Vehicles

Start Time	ALMA ST Southbound					CHURCHILL AVE Westbound					ALMA ST Northbound					CHURCHILL AVE Eastbound					Int. Total
	Right	Thru	Left	Peds	App. Total	Right	Thru	Left	Peds	App. Total	Right	Thru	Left	Peds	App. Total	Right	Thru	Left	Peds	App. Total	
07:00 AM	8	55	1	0	64	2	12	2	0	16	2	123	40	0	165	22	10	10	0	42	287
07:15 AM	17	81	0	0	98	1	16	6	0	23	2	170	47	0	219	11	16	7	0	34	374
07:30 AM	18	95	0	0	113	1	15	12	0	28	5	225	46	0	276	26	22	15	0	63	480
07:45 AM	35	127	5	0	167	2	15	28	0	45	8	326	70	0	404	22	30	8	0	60	676
Total	78	358	6	0	442	6	58	48	0	112	17	844	203	0	1064	81	78	40	0	199	1817
08:00 AM	80	158	0	0	238	0	58	29	0	87	7	370	56	0	433	31	39	14	0	84	842
08:15 AM	46	152	0	0	198	2	28	18	0	48	3	267	61	0	331	22	41	22	0	85	662
08:30 AM	32	183	0	0	215	1	26	20	0	47	2	280	44	0	326	23	30	11	0	64	652
08:45 AM	32	150	0	0	182	0	31	12	0	43	1	250	50	0	301	25	28	27	0	80	606
Total	190	643	0	0	833	3	143	79	0	225	13	1167	211	0	1391	101	138	74	0	313	2762
09:00 AM	36	129	1	0	166	0	16	10	0	26	8	269	69	0	346	17	17	9	0	43	581
09:15 AM	31	143	1	0	175	1	17	13	0	31	6	263	64	0	333	16	19	14	0	49	588
09:30 AM	29	123	1	0	153	0	15	18	0	33	7	253	46	0	306	17	24	17	0	58	550
09:45 AM	25	124	0	0	149	2	19	10	0	31	2	258	56	0	316	20	27	23	0	70	566
Total	121	519	3	0	643	3	67	51	0	121	23	1043	235	0	1301	70	87	63	0	220	2285
10:00 AM	24	110	0	0	134	2	17	4	0	23	4	209	36	0	249	13	22	18	0	53	459
10:15 AM	13	102	2	0	117	0	17	7	0	24	5	202	61	0	268	16	27	23	0	66	475
10:30 AM	25	120	1	0	146	3	19	6	0	28	3	184	51	0	238	18	28	13	0	59	471
10:45 AM	25	100	0	0	125	3	16	2	0	21	5	131	26	0	162	21	11	14	0	46	354
Total	87	432	3	0	522	8	69	19	0	96	17	726	174	0	917	68	88	68	0	224	1759
11:00 AM	26	127	2	0	155	1	15	10	0	26	6	162	20	0	188	19	19	8	0	46	415
11:15 AM	22	137	2	0	161	0	19	7	0	26	4	150	37	0	191	15	15	21	0	51	429
11:30 AM	30	113	1	0	144	0	19	12	0	31	2	125	25	0	152	29	20	36	0	85	412
11:45 AM	33	148	1	0	182	1	18	9	0	28	9	184	45	0	238	22	24	26	0	72	520
Total	111	525	6	0	642	2	71	38	0	111	21	621	127	0	769	85	78	91	0	254	1776
12:00 PM	31	120	2	0	153	0	13	7	0	20	0	157	49	0	206	32	24	25	0	81	460
12:15 PM	32	144	0	0	176	1	11	5	0	17	5	138	29	0	172	25	16	20	0	61	426
12:30 PM	30	131	2	0	163	1	13	10	0	24	7	137	31	0	175	17	19	21	0	57	419
12:45 PM	31	150	4	0	185	0	15	4	0	19	3	153	51	0	207	42	28	28	0	98	509
Total	124	545	8	0	677	2	52	26	0	80	15	585	160	0	760	116	87	94	0	297	1814
01:00 PM	31	142	2	0	175	0	18	8	0	26	1	171	35	0	207	23	27	20	0	70	478
01:15 PM	27	162	0	0	189	0	22	7	0	29	5	174	38	0	217	38	31	38	0	107	542
01:30 PM	23	150	3	0	176	0	27	10	0	37	2	136	40	0	178	17	21	19	0	57	448
01:45 PM	37	158	2	0	197	1	21	11	0	33	1	131	49	0	181	49	22	29	0	100	511
Total	118	612	7	0	737	1	88	36	0	125	9	612	162	0	783	127	101	106	0	334	1979
02:00 PM	30	171	4	0	205	2	21	8	0	31	7	124	40	0	171	42	27	28	0	97	504
02:15 PM	34	176	1	0	211	2	17	11	0	30	2	131	28	0	161	26	26	14	0	66	468
02:30 PM	24	166	1	0	191	3	19	8	0	30	1	154	30	0	185	38	27	23	0	88	494
02:45 PM	27	177	0	0	204	0	17	10	0	27	1	167	53	0	221	43	18	42	0	103	555
Total	115	690	6	0	811	7	74	37	0	118	11	576	151	0	738	149	98	107	0	354	2021
03:00 PM	21	178	1	0	200	0	44	10	0	54	10	128	23	0	161	47	18	25	0	90	505
03:15 PM	31	188	0	0	219	0	22	24	0	46	5	158	30	0	193	61	50	16	0	127	585
03:30 PM	19	202	0	0	221	2	31	12	0	45	5	183	30	0	218	51	32	20	0	103	587
03:45 PM	30	221	2	0	253	1	27	27	0	55	12	201	45	0	258	97	36	19	0	152	718
Total	101	789	3	0	893	3	124	73	0	200	32	670	128	0	830	256	136	80	0	472	2395
04:00 PM	18	231	0	0	249	1	26	24	0	51	4	179	30	0	213	80	33	42	0	155	668
04:15 PM	23	250	0	0	273	3	21	25	0	49	5	169	23	0	197	53	41	30	0	124	643
04:30 PM	37	242	0	0	279	1	23	11	0	35	10	183	32	0	225	70	40	22	0	132	671
04:45 PM	24	269	2	0	295	0	24	16	0	40	7	201	28	0	236	64	45	19	0	128	699
Total	102	992	2	0	1096	5	94	76	0	175	26	732	113	0	871	267	159	113	0	539	2681
05:00 PM	27	230	1	0	258	3	19	23	0	45	10	175	25	0	210	49	33	28	0	110	623

Traffic Data Service

Campbell, CA

(408) 377-2988

tdsbay@cs.com

File Name : 3AMPM FINAL

Site Code : 00000003

Start Date : 11/2/2011

Page No : 2

Groups Printed- Vehicles

Start Time	ALMA ST Southbound					CHURCHILL AVE Westbound					ALMA ST Northbound					CHURCHILL AVE Eastbound					Int. Total
	Right	Thru	Left	Peds	App. Total	Right	Thru	Left	Peds	App. Total	Right	Thru	Left	Peds	App. Total	Right	Thru	Left	Peds	App. Total	
05:15 PM	21	282	0	0	303	0	15	22	0	37	9	176	35	0	220	62	44	17	0	123	683
05:30 PM	25	202	0	0	227	3	33	27	0	63	8	145	27	0	180	69	43	19	0	131	601
05:45 PM	22	240	0	0	262	0	32	18	0	50	4	230	51	0	285	46	56	25	0	127	724
Total	95	954	1	0	1050	6	99	90	0	195	31	726	138	0	895	226	176	89	0	491	2631
06:00 PM	20	206	7	0	233	3	22	8	0	33	8	228	57	0	293	66	42	35	0	143	702
06:15 PM	20	281	3	0	304	2	32	25	0	59	6	216	40	0	262	63	29	34	0	126	751
06:30 PM	36	462	10	0	508	10	30	30	0	70	16	198	30	0	244	78	50	22	0	150	972
06:45 PM	44	341	1	0	386	3	24	45	0	72	19	141	27	0	187	49	46	33	0	128	773
Total	120	1290	21	0	1431	18	108	108	0	234	49	783	154	0	986	256	167	124	0	547	3198
Grand Total	1362	8349	66	0	9777	64	1047	681	0	1792	264	9085	1956	0	11305	1802	1393	1049	0	4244	27118
Apprch %	13.9	85.4	0.7	0		3.6	58.4	38	0		2.3	80.4	17.3	0		42.5	32.8	24.7	0		
Total %	5	30.8	0.2	0	36.1	0.2	3.9	2.5	0	6.6	1	33.5	7.2	0	41.7	6.6	5.1	3.9	0	15.7	

Start Time	ALMA ST Southbound					CHURCHILL AVE Westbound					ALMA ST Northbound					CHURCHILL AVE Eastbound					Int. Total
	Right	Thru	Left	Peds	App. Total	Right	Thru	Left	Peds	App. Total	Right	Thru	Left	Peds	App. Total	Right	Thru	Left	Peds	App. Total	
Peak Hour Analysis From 07:00 AM to 09:45 AM - Peak 1 of 1																					
Peak Hour for Entire Intersection Begins at 07:45 AM																					
07:45 AM	35	127	5	0	167	2	15	28	0	45	8	326	70	0	404	22	30	8	0	60	676
08:00 AM	80	158	0	0	238	0	58	29	0	87	7	370	56	0	433	31	39	14	0	84	842
08:15 AM	46	152	0	0	198	2	28	18	0	48	3	267	61	0	331	22	41	22	0	85	662
08:30 AM	32	183	0	0	215	1	26	20	0	47	2	280	44	0	326	23	30	11	0	64	652
Total Volume	193	620	5	0	818	5	127	95	0	227	20	1243	231	0	1494	98	140	55	0	293	2832
% App. Total	23.6	75.8	0.6	0		2.2	55.9	41.9	0		1.3	83.2	15.5	0		33.4	47.8	18.8	0		
PHF	.603	.847	.250	.000	.859	.625	.547	.819	.000	.652	.625	.840	.825	.000	.863	.790	.854	.625	.000	.862	.841

Traffic Data Service

Campbell, CA
(408) 377-2988
 tdsbay@cs.com

File Name : 3AMPM FINAL
 Site Code : 00000003
 Start Date : 11/2/2011
 Page No : 3

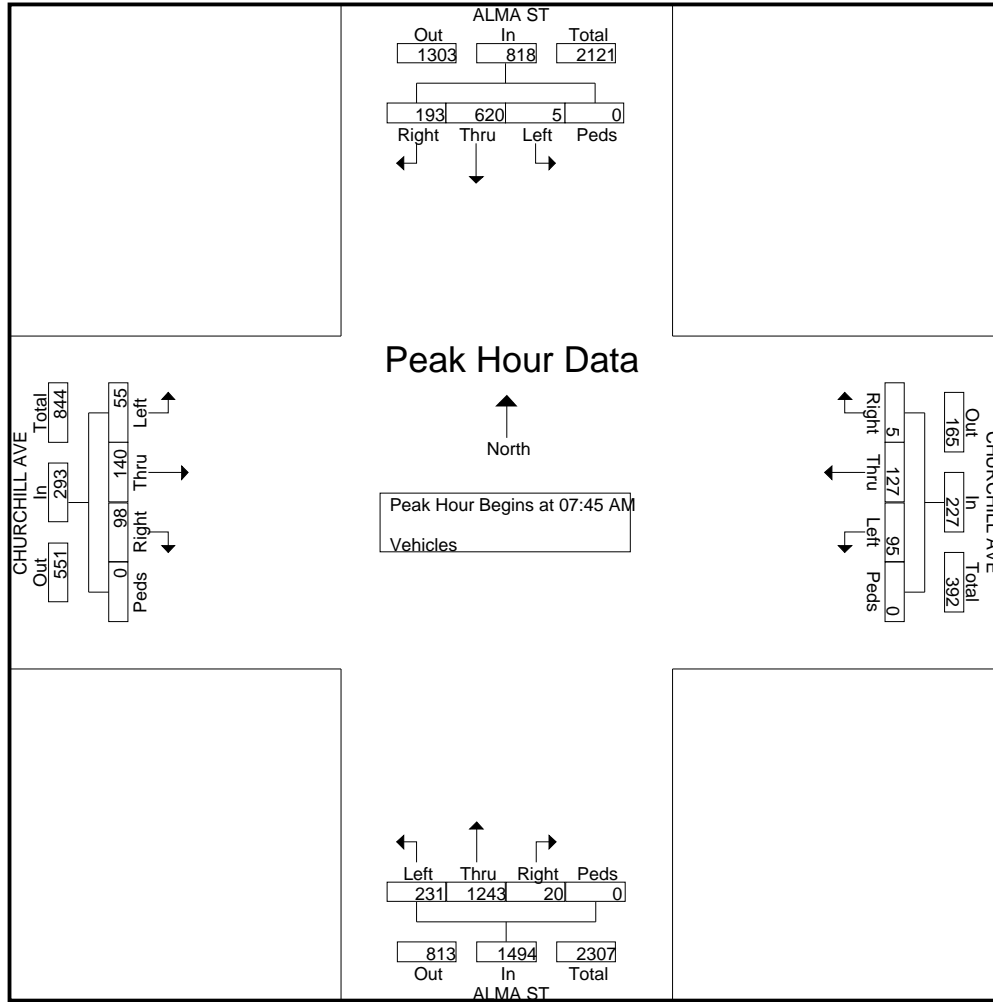

Peak Hour Analysis From 10:00 AM to 01:45 PM - Peak 1 of 1

Peak Hour for Entire Intersection Begins at 01:00 PM

01:00 PM	31	142	2	0	175	0	18	8	0	26	1	171	35	0	207	23	27	20	0	70	478
01:15 PM	27	162	0	0	189	0	22	7	0	29	5	174	38	0	217	38	31	38	0	107	542
01:30 PM	23	150	3	0	176	0	27	10	0	37	2	136	40	0	178	17	21	19	0	57	448
01:45 PM	37	158	2	0	197	1	21	11	0	33	1	131	49	0	181	49	22	29	0	100	511
Total Volume	118	612	7	0	737	1	88	36	0	125	9	612	162	0	783	127	101	106	0	334	1979
% App. Total	16	83	0.9	0		0.8	70.4	28.8	0		1.1	78.2	20.7	0		38	30.2	31.7	0		
PHF	.797	.944	.583	.000	.935	.250	.815	.818	.000	.845	.450	.879	.827	.000	.902	.648	.815	.697	.000	.780	.913

Traffic Data Service

Campbell, CA
(408) 377-2988
 tdsbay@cs.com

File Name : 3AMPM FINAL
 Site Code : 00000003
 Start Date : 11/2/2011
 Page No : 4

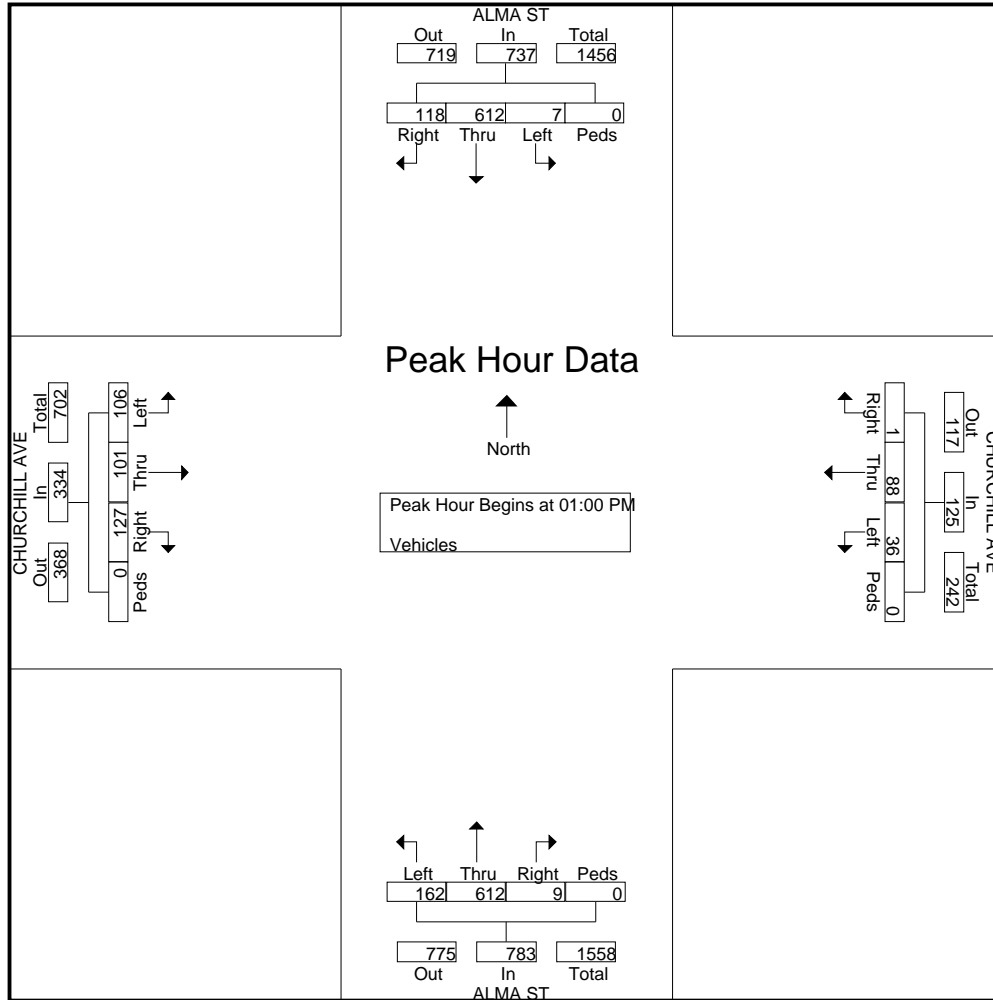

Peak Hour Analysis From 02:00 PM to 06:45 PM - Peak 1 of 1

Peak Hour for Entire Intersection Begins at 06:00 PM

06:00 PM	20	206	7	0	233	3	22	8	0	33	8	228	57	0	293	66	42	35	0	143	702
06:15 PM	20	281	3	0	304	2	32	25	0	59	6	216	40	0	262	63	29	34	0	126	751
06:30 PM	36	462	10	0	508	10	30	30	0	70	16	198	30	0	244	78	50	22	0	150	972
06:45 PM	44	341	1	0	386	3	24	45	0	72	19	141	27	0	187	49	46	33	0	128	773
Total Volume	120	1290	21	0	1431	18	108	108	0	234	49	783	154	0	986	256	167	124	0	547	3198
% App. Total	8.4	90.1	1.5	0		7.7	46.2	46.2	0		5	79.4	15.6	0		46.8	30.5	22.7	0		
PHF	.682	.698	.525	.000	.704	.450	.844	.600	.000	.813	.645	.859	.675	.000	.841	.821	.835	.886	.000	.912	.823

Traffic Data Service

Campbell, CA
(408) 377-2988
 tdsbay@cs.com

File Name : 3AMPM FINAL
 Site Code : 00000003
 Start Date : 11/2/2011
 Page No : 5

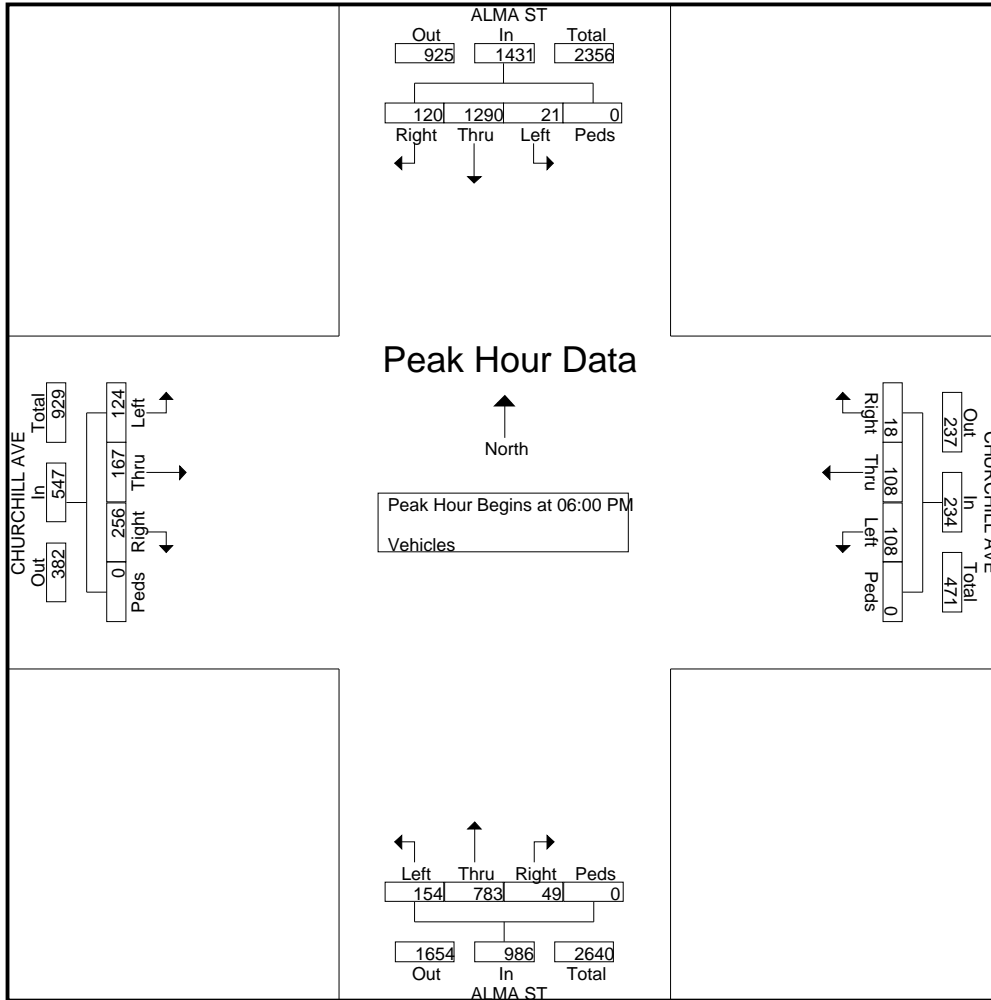

All Traffic Data

(916) 771-8700

City of Palo Alto

File Name : 12-7153-023 Park-West Meadow

Site Code : 00000000

Start Date : 4/17/2012

Page No : 1

Groups Printed- Unshifted

Start Time	Park Boulevard Southbound				West Meadow Drive Westbound				Park Boulevard Northbound				West Meadow Drive Eastbound				Int. Total
	Left	Thru	Right	App. Total	Left	Thru	Right	App. Total	Left	Thru	Right	App. Total	Left	Thru	Right	App. Total	
07:00	0	0	2	2	0	25	4	29	1	0	0	1	0	34	0	34	66
07:15	0	0	2	2	0	34	3	37	0	0	2	2	0	47	1	48	89
07:30	0	0	1	1	0	56	9	65	0	0	9	9	0	71	0	71	146
07:45	0	0	2	2	0	100	9	109	3	0	6	9	0	86	2	88	208
Total	0	0	7	7	0	215	25	240	4	0	17	21	0	238	3	241	509
08:00	0	0	0	0	0	120	20	140	4	0	7	11	0	92	2	94	245
08:15	0	0	3	3	0	81	20	101	1	0	8	9	0	92	0	92	205
08:30	0	0	1	1	0	72	14	86	2	0	3	5	0	98	0	98	190
08:45	0	0	1	1	0	43	16	59	2	0	4	6	0	88	2	90	156
Total	0	0	5	5	0	316	70	386	9	0	22	31	0	370	4	374	796
16:00	1	0	1	2	0	79	17	96	0	0	2	2	0	72	2	74	174
16:15	0	0	2	2	0	58	10	68	0	0	4	4	0	81	2	83	157
16:30	0	0	4	4	0	44	15	59	5	0	5	10	0	88	1	89	162
16:45	0	0	2	2	0	62	16	78	2	0	0	2	0	96	4	100	182
Total	1	0	9	10	0	243	58	301	7	0	11	18	0	337	9	346	675
17:00	0	0	3	3	0	77	20	97	2	1	6	9	0	73	7	80	189
17:15	0	0	1	1	0	90	20	110	2	0	5	7	0	90	4	94	212
17:30	0	0	5	5	0	92	25	117	1	0	5	6	0	87	6	93	221
17:45	0	0	11	11	0	78	22	100	2	0	5	7	0	85	1	86	204
Total	0	0	20	20	0	337	87	424	7	1	21	29	0	335	18	353	826
Grand Total	1	0	41	42	0	1111	240	1351	27	1	71	99	0	1280	34	1314	2806
Apprch %	2.4	0	97.6		0	82.2	17.8		27.3	1	71.7		0	97.4	2.6		
Total %	0	0	1.5	1.5	0	39.6	8.6	48.1	1	0	2.5	3.5	0	45.6	1.2	46.8	

Start Time	Park Boulevard Southbound				West Meadow Drive Westbound				Park Boulevard Northbound				West Meadow Drive Eastbound				Int. Total
	Left	Thru	Right	App. Total	Left	Thru	Right	App. Total	Left	Thru	Right	App. Total	Left	Thru	Right	App. Total	
Peak Hour Analysis From 07:00 to 08:45 - Peak 1 of 1																	
Peak Hour for Entire Intersection Begins at 07:45																	
07:45	0	0	2	2	0	100	9	109	3	0	6	9	0	86	2	88	208
08:00	0	0	0	0	0	120	20	140	4	0	7	11	0	92	2	94	245
08:15	0	0	3	3	0	81	20	101	1	0	8	9	0	92	0	92	205
08:30	0	0	1	1	0	72	14	86	2	0	3	5	0	98	0	98	190
Total Volume	0	0	6	6	0	373	63	436	10	0	24	34	0	368	4	372	848
% App. Total	0	0	100		0	85.6	14.4		29.4	0	70.6		0	98.9	1.1		

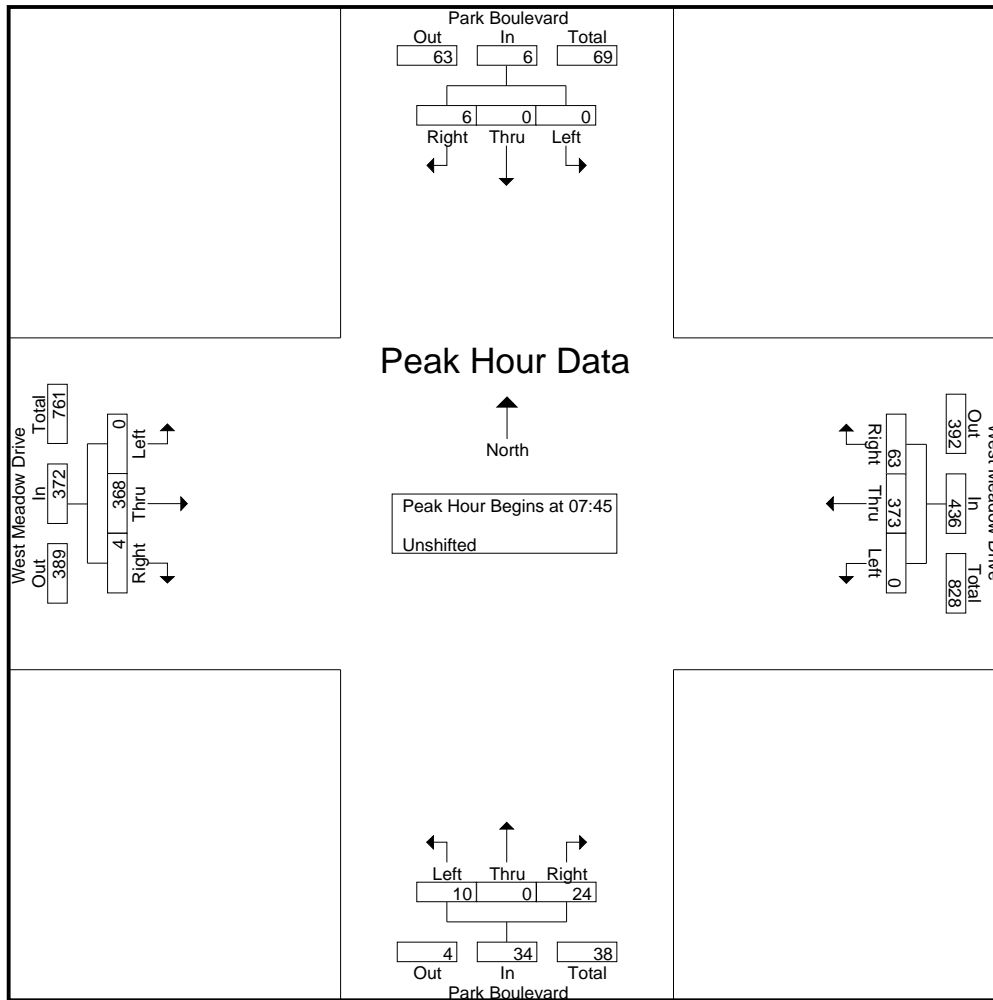

Peak Hour Analysis From 16:00 to 17:45 - Peak 1 of 1
Peak Hour for Entire Intersection Begins at 17:00

17:00	0	0	3	3	0	77	20	97	2	1	6	9	0	73	7	80	189
17:15	0	0	1	1	0	90	20	110	2	0	5	7	0	90	4	94	212
17:30	0	0	5	5	0	92	25	117	1	0	5	6	0	87	6	93	221
17:45	0	0	11	11	0	78	22	100	2	0	5	7	0	85	1	86	204
Total Volume	0	0	20	20	0	337	87	424	7	1	21	29	0	335	18	353	826
% App. Total	0	0	100		0	79.5	20.5		24.1	3.4	72.4		0	94.9	5.1		
PHF	.000	.000	.455	.455	.000	.916	.870	.906	.875	.250	.875	.806	.000	.931	.643	.939	.934

All Traffic Data

(916) 771-8700

City of Palo Alto

File Name : 12-7153-023 Park-West Meadow

Site Code : 00000000

Start Date : 4/17/2012

Page No : 3

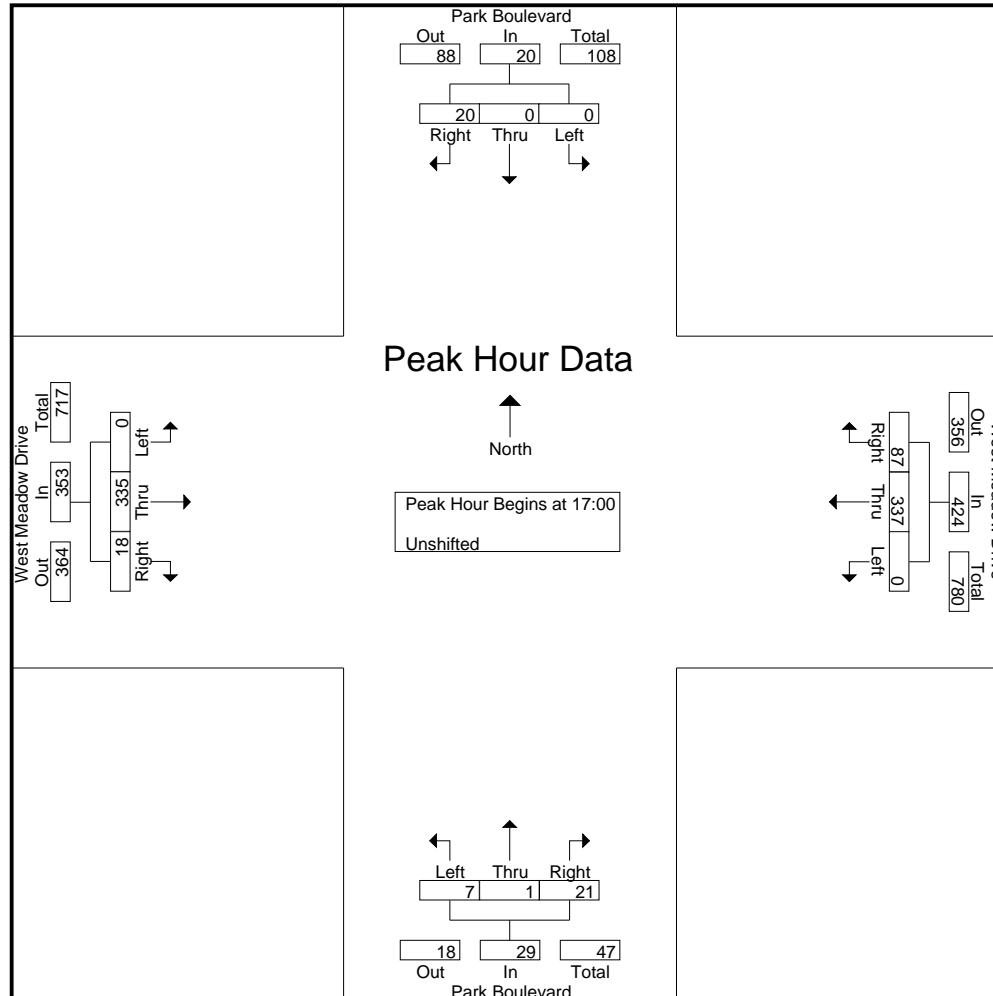

Traffic Data Service

Campbell, CA
(408) 377-2988
tdsbay@cs.com

File Name : 10AM FINAL
 Site Code : 00000001
 Start Date : 5/17/2012
 Page No : 1

Groups Printed- Pedal Bikes

Start Time	ALMA ST Southbound					CHARLESTON RD Westbound					ALMA ST Northbound					CHARLESTON RD Eastbound					Int. Total
	Right	Thru	Left	Peds	App. Total	Right	Thru	Left	Peds	App. Total	Right	Thru	Left	Peds	App. Total	Right	Thru	Left	Peds	App. Total	
07:00 AM	0	0	0	0	0	0	3	0	0	3	0	0	0	0	0	0	2	0	0	2	5
07:15 AM	0	0	0	0	0	0	5	0	0	5	0	1	0	0	1	0	1	1	0	2	8
07:30 AM	0	1	0	0	1	0	2	0	0	2	0	0	0	0	0	0	7	0	0	7	10
07:45 AM	0	0	0	0	0	0	15	0	0	15	0	0	0	0	0	1	3	0	0	4	19
Total	0	1	0	0	1	0	25	0	0	25	0	1	0	0	1	1	13	1	0	15	42
08:00 AM	0	0	0	0	0	0	34	0	0	34	0	3	1	0	4	0	5	0	0	5	43
08:15 AM	0	0	0	0	0	0	14	0	0	14	0	3	0	0	3	0	14	0	0	14	31
08:30 AM	0	0	0	0	0	0	8	0	0	8	0	0	0	0	0	0	5	0	0	5	13
08:45 AM	0	0	0	0	0	0	5	0	0	5	0	0	0	0	0	0	0	0	0	0	5
Total	0	0	0	0	0	0	61	0	0	61	0	6	1	0	7	0	24	0	0	24	92
09:00 AM	0	0	0	0	0	0	5	0	0	5	0	1	0	0	1	1	14	0	0	15	21
09:15 AM	0	1	0	0	1	0	7	0	0	7	0	0	0	0	0	1	7	0	0	8	16
09:30 AM	0	0	0	0	0	0	6	0	0	6	0	0	0	0	0	0	1	0	0	1	7
09:45 AM	0	0	0	0	0	0	4	0	0	4	0	0	0	0	0	0	2	0	0	2	6
Total	0	1	0	0	1	0	22	0	0	22	0	1	0	0	1	2	24	0	0	26	50
Grand Total	0	2	0	0	2	0	108	0	0	108	0	8	1	0	9	3	61	1	0	65	184
Apprch %	0	100	0	0		0	100	0	0		0	88.9	11.1	0		4.6	93.8	1.5	0		
Total %	0	1.1	0	0	1.1	0	58.7	0	0	58.7	0	4.3	0.5	0	4.9	1.6	33.2	0.5	0	35.3	

Start Time	ALMA ST Southbound					CHARLESTON RD Westbound					ALMA ST Northbound					CHARLESTON RD Eastbound					Int. Total
	Right	Thru	Left	Peds	App. Total	Right	Thru	Left	Peds	App. Total	Right	Thru	Left	Peds	App. Total	Right	Thru	Left	Peds	App. Total	
Peak Hour Analysis From 07:00 AM to 09:45 AM - Peak 1 of 1																					
Peak Hour for Entire Intersection Begins at 07:45 AM																					
07:45 AM	0	0	0	0	0	0	15	0	0	15	0	0	0	0	0	1	3	0	0	4	19
08:00 AM	0	0	0	0	0	0	34	0	0	34	0	3	1	0	4	0	5	0	0	5	43
08:15 AM	0	0	0	0	0	0	14	0	0	14	0	3	0	0	3	0	14	0	0	14	31
08:30 AM	0	0	0	0	0	0	8	0	0	8	0	0	0	0	0	0	5	0	0	5	13
Total Volume	0	0	0	0	0	0	71	0	0	71	0	6	1	0	7	1	27	0	0	28	106
% App. Total	0	0	0	0		0	100	0	0		0	85.7	14.3	0		3.6	96.4	0	0		
PHF	.000	.000	.000	.000	.000	.000	.522	.000	.000	.522	.000	.500	.250	.000	.438	.250	.482	.000	.000	.500	.616

Traffic Data Service

Campbell, CA

(408) 377-2988

tdsbay@cs.com

File Name : 10AM FINAL

Site Code : 00000001

Start Date : 5/17/2012

Page No : 2

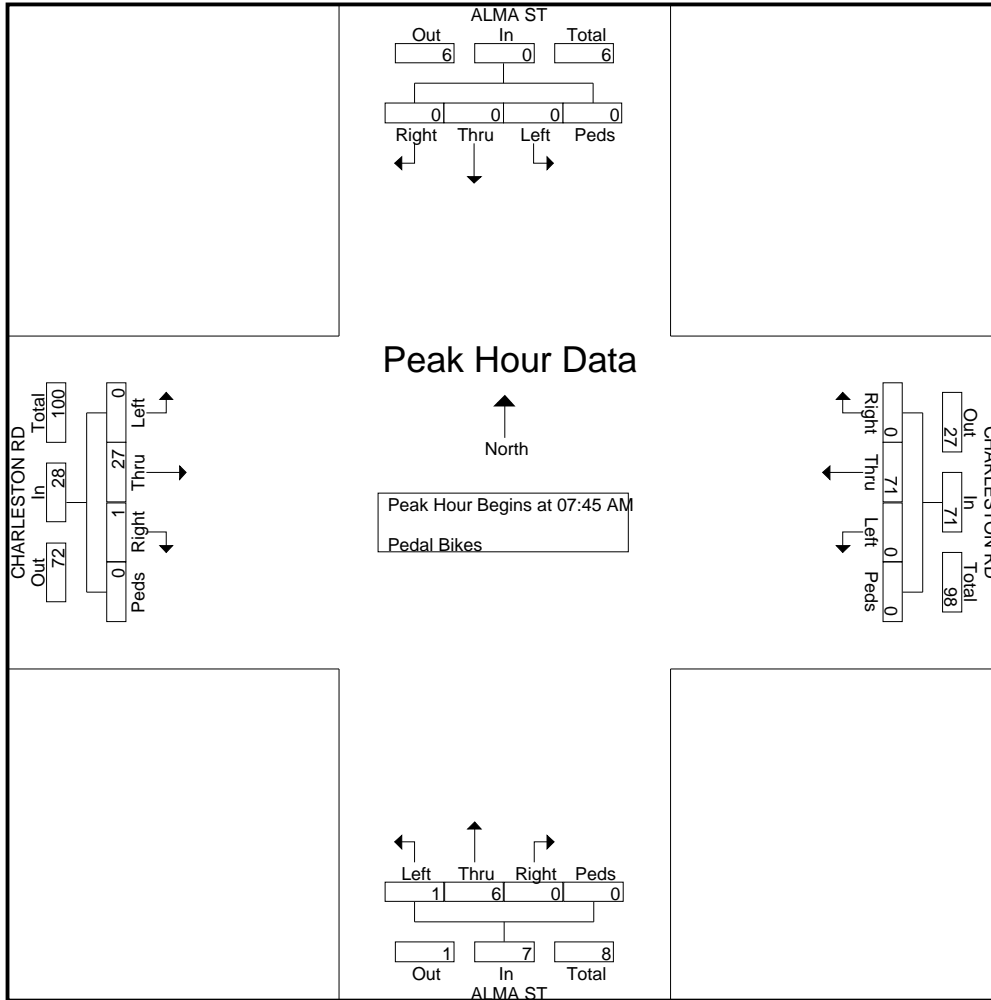

Traffic Data Service

Campbell, CA

(408) 377-2988

tdsbay@cs.com

File Name : 10AM FINAL

Site Code : 00000001

Start Date : 5/17/2012

Page No : 1

Groups Printed- Vehicles - Motor Bikes

Start Time	ALMA ST Southbound					CHARLESTON RD Westbound					ALMA ST Northbound					CHARLESTON RD Eastbound					Int. Total
	Right	Thru	Left	Peds	App. Total	Right	Thru	Left	Peds	App. Total	Right	Thru	Left	Peds	App. Total	Right	Thru	Left	Peds	App. Total	
07:00 AM	5	57	7	0	69	10	46	1	0	57	6	175	44	1	226	8	41	12	0	61	413
07:15 AM	9	91	7	0	107	15	50	3	0	68	4	284	31	0	319	17	48	14	0	79	573
07:30 AM	14	89	11	1	115	13	52	5	0	70	4	302	59	8	373	21	90	12	0	123	681
07:45 AM	6	133	16	6	161	31	84	13	0	128	2	331	61	3	397	16	114	26	0	156	842
Total	34	370	41	7	452	69	232	22	0	323	16	1092	195	12	1315	62	293	64	0	419	2509
08:00 AM	11	180	8	5	204	21	62	18	5	106	7	350	55	6	418	26	87	28	0	141	869
08:15 AM	12	198	15	2	227	33	74	24	4	135	6	316	47	6	375	44	122	27	0	193	930
08:30 AM	20	189	15	0	224	23	73	18	3	117	16	345	41	3	405	21	96	32	0	149	895
08:45 AM	27	208	35	0	270	24	65	10	0	99	14	354	80	5	453	36	118	33	0	187	1009
Total	70	775	73	7	925	101	274	70	12	457	43	1365	223	20	1651	127	423	120	0	670	3703
09:00 AM	13	166	19	1	199	22	80	9	0	111	16	246	64	2	328	37	105	20	0	162	800
09:15 AM	16	132	22	1	171	17	88	14	1	120	11	276	53	3	343	18	84	19	0	121	755
09:30 AM	18	153	19	1	191	15	48	12	3	78	9	288	34	0	331	16	62	26	0	104	704
09:45 AM	10	118	27	1	156	23	47	7	0	77	7	254	105	0	366	22	101	18	0	141	740
Total	57	569	87	4	717	77	263	42	4	386	43	1064	256	5	1368	93	352	83	0	528	2999
Grand Total	161	1714	201	18	2094	247	769	134	16	1166	102	3521	674	37	4334	282	1068	267	0	1617	9211
Apprch %	7.7	81.9	9.6	0.9		21.2	66	11.5	1.4		2.4	81.2	15.6	0.9		17.4	66	16.5	0		
Total %	1.7	18.6	2.2	0.2	22.7	2.7	8.3	1.5	0.2	12.7	1.1	38.2	7.3	0.4	47.1	3.1	11.6	2.9	0	17.6	
Vehicles	161	1709	200	18	2088	247	762	133	16	1158	102	3510	669	37	4318	282	1066	267	0	1615	9179
% Vehicles	100	99.7	99.5	100	99.7	100	99.1	99.3	100	99.3	100	99.7	99.3	100	99.6	100	99.8	100	0	99.9	99.7
Motor Bikes	0	5	1	0	6	0	7	1	0	8	0	11	5	0	16	0	2	0	0	2	32
% Motor Bikes																					

Start Time	ALMA ST Southbound					CHARLESTON RD Westbound					ALMA ST Northbound					CHARLESTON RD Eastbound					Int. Total
	Right	Thru	Left	Peds	App. Total	Right	Thru	Left	Peds	App. Total	Right	Thru	Left	Peds	App. Total	Right	Thru	Left	Peds	App. Total	
Peak Hour Analysis From 07:00 AM to 09:45 AM - Peak 1 of 1																					
Peak Hour for Entire Intersection Begins at 08:00 AM																					
08:00 AM	11	180	8	5	204	21	62	18	5	106	7	350	55	6	418	26	87	28	0	141	869
08:15 AM	12	198	15	2	227	33	74	24	4	135	6	316	47	6	375	44	122	27	0	193	930
08:30 AM	20	189	15	0	224	23	73	18	3	117	16	345	41	3	405	21	96	32	0	149	895
08:45 AM	27	208	35	0	270	24	65	10	0	99	14	354	80	5	453	36	118	33	0	187	1009
Total Volume	70	775	73	7	925	101	274	70	12	457	43	1365	223	20	1651	127	423	120	0	670	3703
% App. Total																					
PHF	.648	.931	.521	.350	.856	.765	.926	.729	.600	.846	.672	.964	.697	.833	.911	.722	.867	.909	.000	.868	.917

Traffic Data Service

Campbell, CA

(408) 377-2988

tdsbay@cs.com

File Name : 10AM FINAL

Site Code : 00000001

Start Date : 5/17/2012

Page No : 2

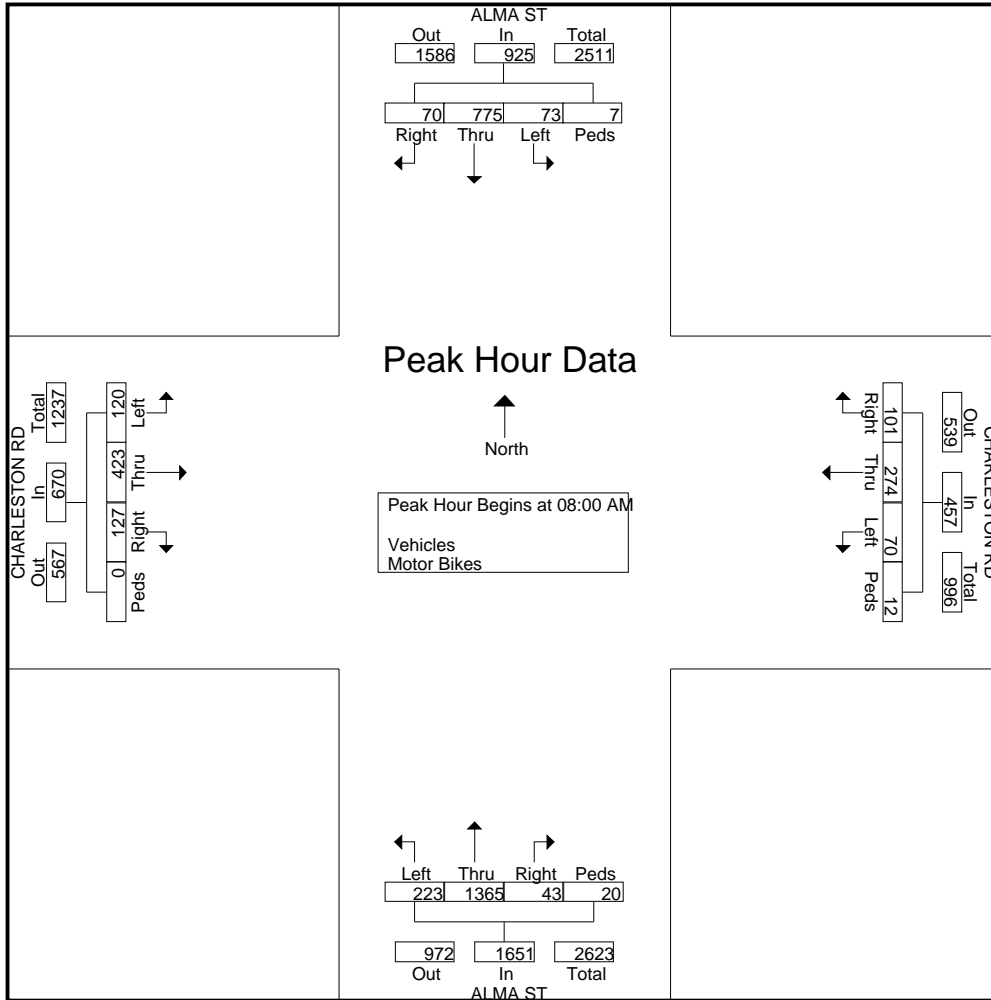

Traffic Data Service

Campbell, CA

(408) 377-2988

tdsbay@cs.com

File Name : 10PM FINAL

Site Code : 00000001

Start Date : 5/17/2012

Page No : 1

Groups Printed- Pedal Bikes

Start Time	ALMA ST Southbound					CHARLESTON RD Westbound					ALMA ST Northbound					CHARLESTON RD Eastbound					Int. Total
	Right	Thru	Left	Peds	App. Total	Right	Thru	Left	Peds	App. Total	Right	Thru	Left	Peds	App. Total	Right	Thru	Left	Peds	App. Total	
04:00 PM	0	0	0	0	0	0	0	0	0	0	0	0	0	0	0	0	3	0	0	3	3
04:15 PM	0	1	0	0	1	0	6	0	0	6	0	0	0	0	0	0	5	0	0	5	12
04:30 PM	0	0	0	0	0	0	6	0	0	6	0	0	0	0	0	1	9	0	0	10	16
04:45 PM	0	0	0	0	0	0	1	0	0	1	1	0	0	0	1	0	3	0	0	3	5
Total	0	1	0	0	1	0	13	0	0	13	1	0	0	0	1	1	20	0	0	21	36
05:00 PM	0	2	0	0	2	0	10	0	0	10	0	0	1	0	1	0	0	0	0	0	13
05:15 PM	0	2	0	0	2	0	5	0	0	5	0	1	2	0	3	0	5	0	0	5	15
05:30 PM	0	2	0	0	2	0	5	0	0	5	0	0	0	0	0	0	4	0	0	4	11
05:45 PM	0	0	0	0	0	1	6	0	0	7	0	1	0	0	1	1	11	0	0	12	20
Total	0	6	0	0	6	1	26	0	0	27	0	2	3	0	5	1	20	0	0	21	59
06:00 PM	0	0	0	0	0	0	5	0	0	5	0	0	0	0	0	0	6	0	0	6	11
06:15 PM	0	0	0	0	0	0	5	0	0	5	0	0	0	0	0	0	7	0	0	7	12
06:30 PM	0	0	0	0	0	0	7	0	0	7	0	0	0	0	0	0	5	0	0	5	12
06:45 PM	0	0	0	0	0	0	6	0	0	6	0	0	0	0	0	0	7	0	0	7	13
Total	0	0	0	0	0	0	23	0	0	23	0	0	0	0	0	0	25	0	0	25	48
Grand Total	0	7	0	0	7	1	62	0	0	63	1	2	3	0	6	2	65	0	0	67	143
Apprch %	0	100	0	0		1.6	98.4	0	0		16.7	33.3	50	0		3	97	0	0		
Total %	0	4.9	0	0	4.9	0.7	43.4	0	0	44.1	0.7	1.4	2.1	0	4.2	1.4	45.5	0	0	46.9	

Start Time	ALMA ST Southbound					CHARLESTON RD Westbound					ALMA ST Northbound					CHARLESTON RD Eastbound					Int. Total
	Right	Thru	Left	Peds	App. Total	Right	Thru	Left	Peds	App. Total	Right	Thru	Left	Peds	App. Total	Right	Thru	Left	Peds	App. Total	
Peak Hour Analysis From 04:00 PM to 06:45 PM - Peak 1 of 1																					
Peak Hour for Entire Intersection Begins at 05:00 PM																					
05:00 PM	0	2	0	0	2	0	10	0	0	10	0	0	1	0	1	0	0	0	0	0	13
05:15 PM	0	2	0	0	2	0	5	0	0	5	0	1	2	0	3	0	5	0	0	5	15
05:30 PM	0	2	0	0	2	0	5	0	0	5	0	0	0	0	0	0	4	0	0	4	11
05:45 PM	0	0	0	0	0	1	6	0	0	7	0	1	0	0	1	1	11	0	0	12	20
Total Volume	0	6	0	0	6	1	26	0	0	27	0	2	3	0	5	1	20	0	0	21	59
% App. Total	0	100	0	0		3.7	96.3	0	0		0	40	60	0		4.8	95.2	0	0		
PHF	.000	.750	.000	.000	.750	.250	.650	.000	.000	.675	.000	.500	.375	.000	.417	.250	.455	.000	.000	.438	.738

Traffic Data Service

Campbell, CA
(408) 377-2988
 tdsbay@cs.com

File Name : 10PM FINAL
 Site Code : 0000001
 Start Date : 5/17/2012
 Page No : 2

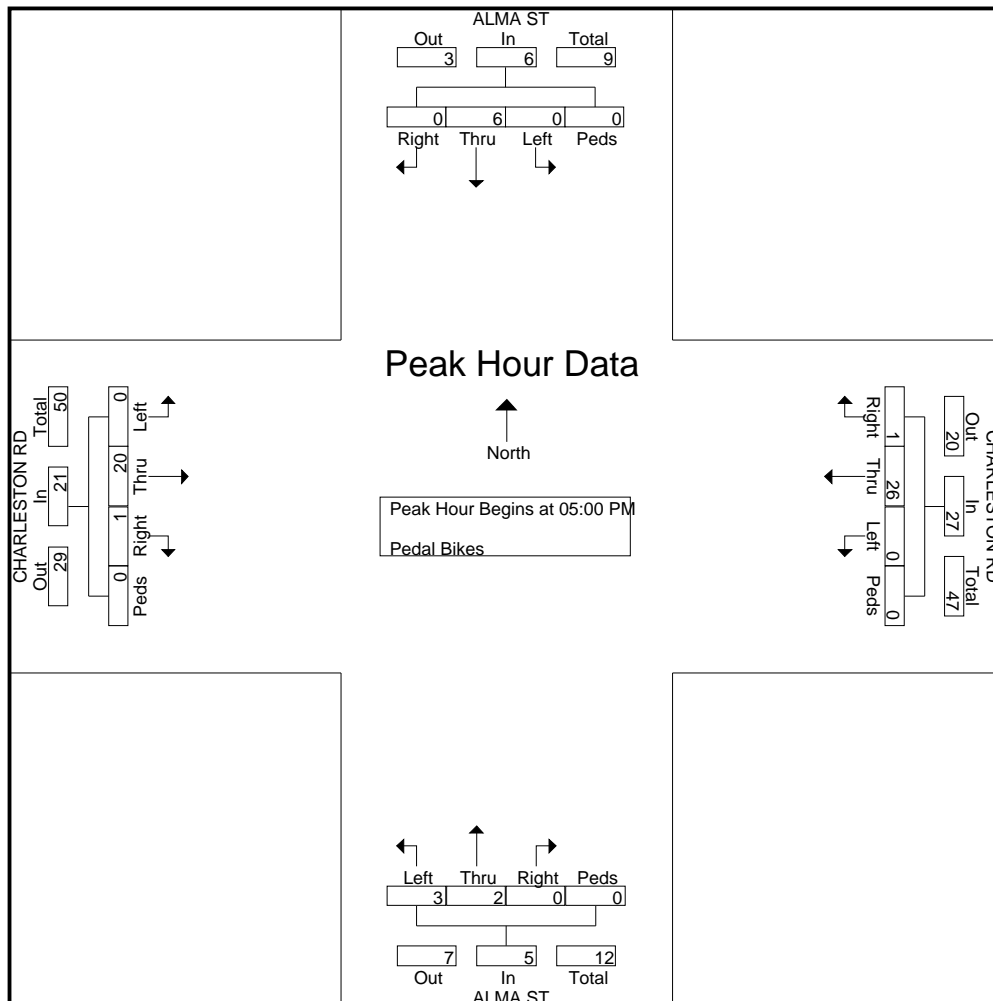

Traffic Data Service

Campbell, CA

(408) 377-2988

tdsbay@cs.com

File Name : 10PM FINAL

Site Code : 00000001

Start Date : 5/17/2012

Page No : 1

Groups Printed- Vehicles - Motor Bikes

Start Time	ALMA ST Southbound					CHARLESTON RD Westbound					ALMA ST Northbound					CHARLESTON RD Eastbound					Int. Total
	Right	Thru	Left	Peds	App. Total	Right	Thru	Left	Peds	App. Total	Right	Thru	Left	Peds	App. Total	Right	Thru	Left	Peds	App. Total	
04:00 PM	21	263	27	2	313	32	76	18	0	126	11	170	22	3	206	38	85	22	0	145	790
04:15 PM	19	289	35	0	343	27	84	5	1	117	12	223	47	1	283	56	73	30	0	159	902
04:30 PM	16	286	12	3	317	36	91	9	0	136	15	227	35	2	279	47	80	23	1	151	883
04:45 PM	16	335	37	2	390	23	68	9	3	103	13	292	47	2	354	57	88	22	0	167	1014
Total	72	1173	111	7	1363	118	319	41	4	482	51	912	151	8	1122	198	326	97	1	622	3589
05:00 PM	25	319	29	2	375	22	108	9	3	142	14	254	44	0	312	48	90	20	0	158	987
05:15 PM	23	319	21	2	365	27	123	17	0	167	18	260	47	2	327	37	77	18	0	132	991
05:30 PM	18	319	36	3	376	32	79	16	0	127	22	294	52	2	370	66	114	26	0	206	1079
05:45 PM	30	303	18	0	351	26	91	12	0	129	23	276	41	1	341	51	100	25	0	176	997
Total	96	1260	104	7	1467	107	401	54	3	565	77	1084	184	5	1350	202	381	89	0	672	4054
06:00 PM	18	321	25	3	367	27	96	17	1	141	17	300	56	3	376	55	91	18	0	164	1048
06:15 PM	16	291	30	0	337	23	115	10	2	150	17	248	49	2	316	58	113	11	0	182	985
06:30 PM	21	332	22	1	376	18	101	10	1	130	10	259	35	4	308	43	70	18	1	132	946
06:45 PM	16	275	29	2	322	24	82	10	1	117	9	221	43	6	279	36	57	12	0	105	823
Total	71	1219	106	6	1402	92	394	47	5	538	53	1028	183	15	1279	192	331	59	1	583	3802
Grand Total	239	3652	321	20	4232	317	1114	142	12	1585	181	3024	518	28	3751	592	1038	245	2	1877	11445
Apprch %	5.6	86.3	7.6	0.5		20	70.3	9	0.8		4.8	80.6	13.8	0.7		31.5	55.3	13.1	0.1		
Total %	2.1	31.9	2.8	0.2	37	2.8	9.7	1.2	0.1	13.8	1.6	26.4	4.5	0.2	32.8	5.2	9.1	2.1	0	16.4	
Vehicles	239	3640	321	20	4220	316	1109	142	12	1579	181	3015	518	28	3742	590	1025	245	2	1862	11403
% Vehicles	100	99.7	100	100	99.7	99.7	99.6	100	100	99.6	100	99.7	100	100	99.8	99.7	98.7	100	100	99.2	99.6
Motor Bikes	0	12	0	0	12	1	5	0	0	6	0	9	0	0	9	2	13	0	0	15	42
% Motor Bikes																					

Start Time	ALMA ST Southbound					CHARLESTON RD Westbound					ALMA ST Northbound					CHARLESTON RD Eastbound					Int. Total
	Right	Thru	Left	Peds	App. Total	Right	Thru	Left	Peds	App. Total	Right	Thru	Left	Peds	App. Total	Right	Thru	Left	Peds	App. Total	
Peak Hour Analysis From 04:00 PM to 06:45 PM - Peak 1 of 1																					
Peak Hour for Entire Intersection Begins at 05:15 PM																					
05:15 PM	23	319	21	2	365	27	123	17	0	167	18	260	47	2	327	37	77	18	0	132	991
05:30 PM	18	319	36	3	376	32	79	16	0	127	22	294	52	2	370	66	114	26	0	206	1079
05:45 PM	30	303	18	0	351	26	91	12	0	129	23	276	41	1	341	51	100	25	0	176	997
06:00 PM	18	321	25	3	367	27	96	17	1	141	17	300	56	3	376	55	91	18	0	164	1048
Total Volume	89	1262	100	8	1459	112	389	62	1	564	80	1130	196	8	1414	209	382	87	0	678	4115
% App. Total																					
PHF	.742	.983	.694	.667	.970	.875	.791	.912	.250	.844	.870	.942	.875	.667	.940	.792	.838	.837	.000	.823	.953

Traffic Data Service

Campbell, CA
(408) 377-2988
 tdsbay@cs.com

File Name : 10PM FINAL
 Site Code : 00000001
 Start Date : 5/17/2012
 Page No : 2

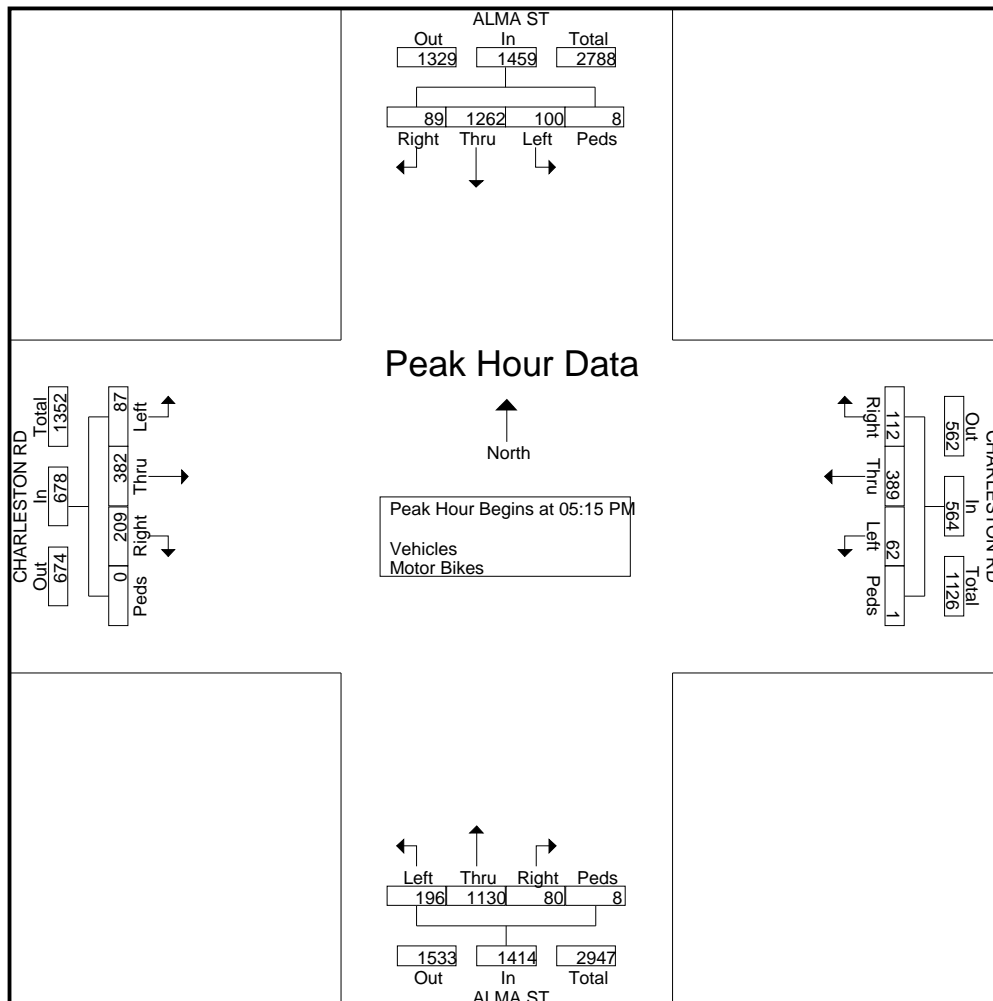

Traffic Data Service

Campbell, CA
 (408) 377-2988
 tdsbay@cs.com

File Name : 24AM FINAL
 Site Code : 00000024
 Start Date : 5/22/2013
 Page No : 1

Groups Printed- Vehicles

Start Time	SHOWERS DR Southbound					Westbound					SHOWERS DR Northbound					PACCHETTI WAY Eastbound					Int. Total
	Right	Thru	Left	Peds	App. Total	Right	Thru	Left	Peds	App. Total	Right	Thru	Left	Peds	App. Total	Right	Thru	Left	Peds	App. Total	
07:00 AM	1	8	0	0	9	0	0	0	0	0	0	6	0	4	10	1	0	0	1	2	21
07:15 AM	7	11	4	5	27	0	0	0	0	0	0	11	3	6	20	0	0	1	0	1	48
07:30 AM	6	8	3	6	23	0	0	0	0	0	0	4	0	1	5	0	0	1	5	6	34
07:45 AM	7	15	1	1	24	0	0	0	0	0	0	4	0	0	4	1	0	0	0	1	29
Total	21	42	8	12	83	0	0	0	0	0	0	25	3	11	39	2	0	2	6	10	132
08:00 AM	2	12	2	3	19	0	0	0	0	0	0	3	1	0	4	0	0	0	2	2	25
08:15 AM	4	13	2	3	22	0	0	0	0	0	0	10	4	7	21	0	0	1	6	7	50
08:30 AM	7	15	2	5	29	0	0	0	0	0	0	6	4	6	16	0	0	1	3	4	49
08:45 AM	8	13	0	5	26	0	0	0	0	0	0	5	2	6	13	1	0	2	1	4	43
Total	21	53	6	16	96	0	0	0	0	0	0	24	11	19	54	1	0	4	12	17	167
Grand Total	42	95	14	28	179	0	0	0	0	0	0	49	14	30	93	3	0	6	18	27	299
Apprch %	23.5	53.1	7.8	15.6		0	0	0	0	0	0	52.7	15.1	32.3		11.1	0	22.2	66.7		
Total %	14	31.8	4.7	9.4	59.9	0	0	0	0	0	0	16.4	4.7	10	31.1	1	0	2	6	9	

Start Time	SHOWERS DR Southbound				Westbound				SHOWERS DR Northbound				PACCHETTI WAY Eastbound				Int. Total
	Right	Thru	Left	App. Total	Right	Thru	Left	App. Total	Right	Thru	Left	App. Total	Right	Thru	Left	App. Total	
Peak Hour Analysis From 07:00 AM to 08:45 AM - Peak 1 of 1																	
Peak Hour for Entire Intersection Begins at 08:00 AM																	
08:00 AM	2	12	2	16	0	0	0	0	0	3	1	4	0	0	0	0	20
08:15 AM	4	13	2	19	0	0	0	0	0	10	4	14	0	0	1	1	34
08:30 AM	7	15	2	24	0	0	0	0	0	6	4	10	0	0	1	1	35
08:45 AM	8	13	0	21	0	0	0	0	0	5	2	7	1	0	2	3	31
Total Volume	21	53	6	80	0	0	0	0	0	24	11	35	1	0	4	5	120
% App. Total	26.2	66.2	7.5		0	0	0		0	68.6	31.4		20	0	80		
PHF	.656	.883	.750	.833	.000	.000	.000	.000	.000	.600	.688	.625	.250	.000	.500	.417	.857

Traffic Data Service

Campbell, CA
 (408) 377-2988
 tdsbay@cs.com

File Name : 24AM FINAL
 Site Code : 00000024
 Start Date : 5/22/2013
 Page No : 2

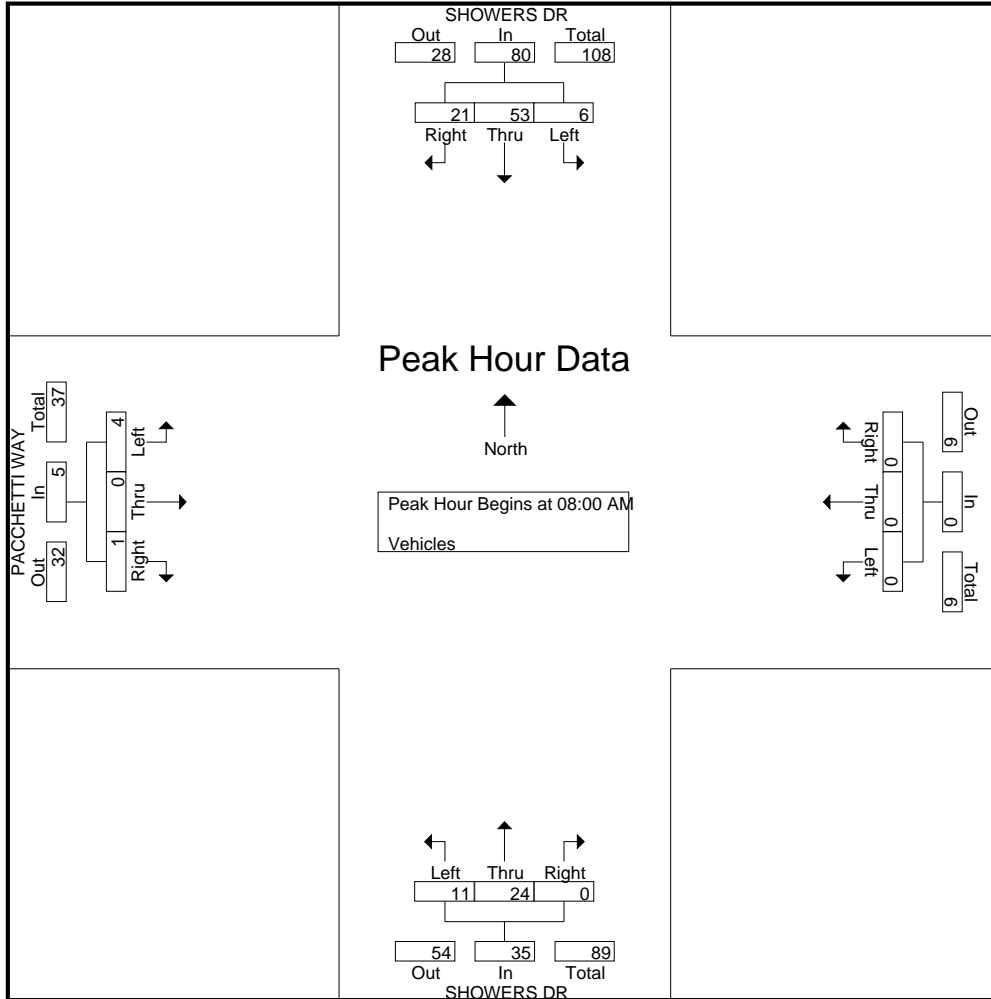

Traffic Data Service

Campbell, CA
 (408) 377-2988
 tdsbay@cs.com

File Name : 24AM FINAL
 Site Code : 00000024
 Start Date : 5/22/2013
 Page No : 1

Groups Printed- Bikes

Start Time	SHOWERS DR Southbound					Westbound					SHOWERS DR Northbound					PACCHETTI WAY Eastbound					Int. Total
	Right	Thru	Left	Peds	App. Total	Right	Thru	Left	Peds	App. Total	Right	Thru	Left	Peds	App. Total	Right	Thru	Left	Peds	App. Total	
07:00 AM	0	0	0	0	0	0	0	0	0	0	0	2	0	0	2	0	0	0	0	0	0
07:15 AM	0	0	0	0	0	0	0	0	0	0	0	0	0	0	0	0	0	0	0	0	0
07:30 AM	1	1	0	0	2	0	0	0	0	0	0	1	0	0	1	0	0	0	0	0	3
07:45 AM	0	1	0	0	1	0	0	0	0	0	0	0	0	0	0	0	0	0	0	0	1
Total	1	2	0	0	3	0	0	0	0	0	0	3	0	0	3	0	0	0	0	0	6
08:00 AM	0	0	0	0	0	0	0	0	0	0	0	0	0	0	0	0	0	0	0	0	0
08:15 AM	0	0	0	0	0	0	0	0	0	0	0	1	0	0	1	0	0	0	0	0	1
08:30 AM	0	4	0	0	4	0	0	0	0	0	0	0	0	0	0	0	0	0	0	0	4
08:45 AM	0	0	0	0	0	0	0	0	0	0	0	0	0	0	0	0	0	0	0	0	0
Total	0	4	0	0	4	0	0	0	0	0	0	1	0	0	1	0	0	0	0	0	5
Grand Total	1	6	0	0	7	0	0	0	0	0	0	4	0	0	4	0	0	0	0	0	11
Apprch %	14.3	85.7	0	0		0	0	0	0		0	100	0	0		0	0	0	0		
Total %	9.1	54.5	0	0	63.6	0	0	0	0		0	36.4	0	0	36.4	0	0	0	0		

Start Time	SHOWERS DR Southbound					Westbound					SHOWERS DR Northbound					PACCHETTI WAY Eastbound					Int. Total
	Right	Thru	Left	Peds	App. Total	Right	Thru	Left	Peds	App. Total	Right	Thru	Left	Peds	App. Total	Right	Thru	Left	Peds	App. Total	
07:00 AM	0	0	0	0	0	0	0	0	0	0	0	2	0	0	2	0	0	0	0	0	2
07:15 AM	0	0	0	0	0	0	0	0	0	0	0	0	0	0	0	0	0	0	0	0	0
07:30 AM	1	1	0	0	2	0	0	0	0	0	0	1	0	0	1	0	0	0	0	0	3
07:45 AM	0	1	0	0	1	0	0	0	0	0	0	0	0	0	0	0	0	0	0	0	1
Total Volume	1	2	0	0	3	0	0	0	0	0	0	3	0	0	3	0	0	0	0	0	6
% App. Total	33.3	66.7	0	0		0	0	0	0		0	100	0	0		0	0	0	0		
PHF	.250	.500	.000	.000	.375	.000	.000	.000	.000	.000	.000	.375	.000	.000	.375	.000	.000	.000	.000	.000	.500

Peak Hour Analysis From 07:00 AM to 08:45 AM - Peak 1 of 1

Peak Hour for Entire Intersection Begins at 07:00 AM

Traffic Data Service

Campbell, CA
(408) 377-2988
tdsbay@cs.com

File Name : 24AM FINAL
Site Code : 00000024
Start Date : 5/22/2013
Page No : 2

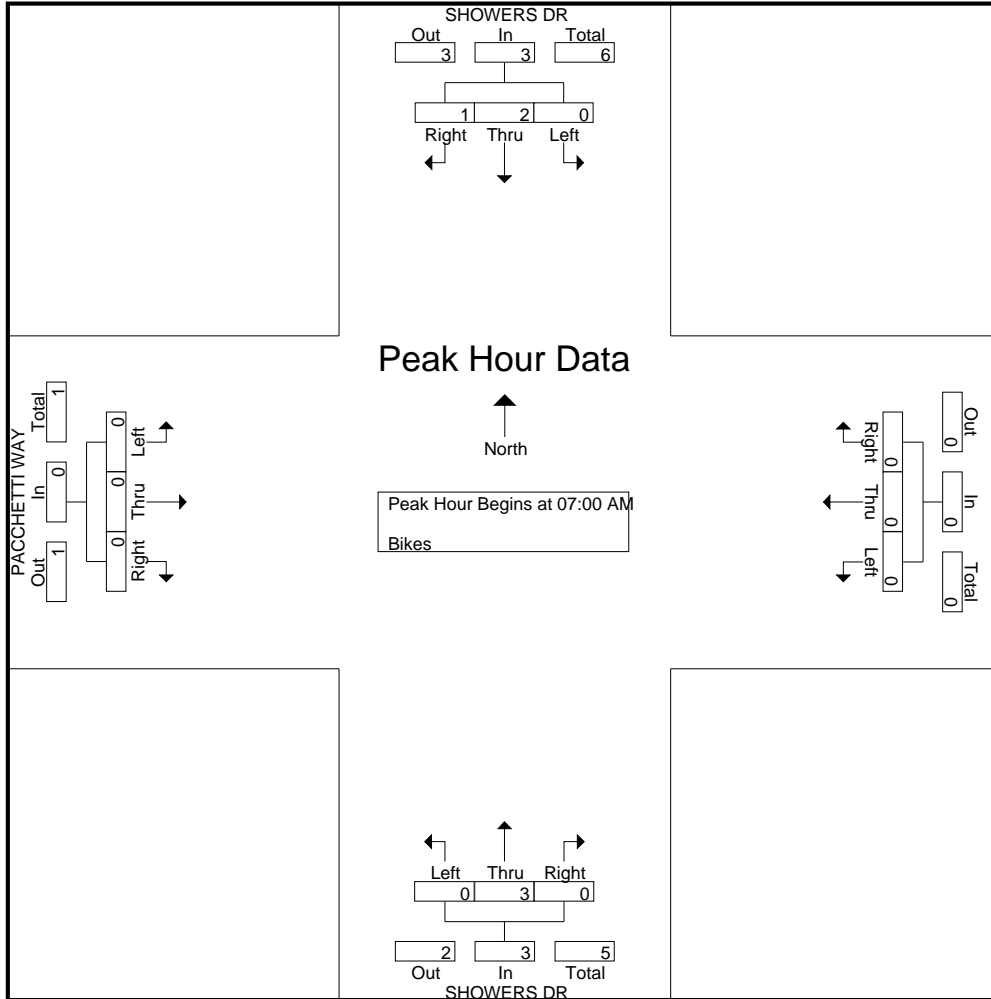

Traffic Data Service

Campbell, CA
 (408) 377-2988
 tdsbay@cs.com

File Name : 24PM FINAL
 Site Code : 00000024
 Start Date : 5/22/2013
 Page No : 1

Groups Printed- Vehicles

Start Time	SHOWERS DR Southbound					Westbound					SHOWERS DR Northbound					PACCHETTI WAY Eastbound					Int. Total
	Right	Thru	Left	Peds	App. Total	Right	Thru	Left	Peds	App. Total	Right	Thru	Left	Peds	App. Total	Right	Thru	Left	Peds	App. Total	
04:00 PM	10	32	0	5	47	0	0	0	0	0	0	5	1	4	10	1	0	1	1	3	60
04:15 PM	11	28	2	1	42	0	0	0	0	0	0	2	0	3	5	2	0	3	0	5	52
04:30 PM	15	31	1	2	49	0	0	0	0	0	0	4	2	2	8	3	0	0	3	6	63
04:45 PM	9	37	1	2	49	0	0	0	0	0	0	9	1	3	13	2	0	1	3	6	68
Total	45	128	4	10	187	0	0	0	0	0	0	20	4	12	36	8	0	5	7	20	243
05:00 PM	8	29	0	2	39	0	0	0	0	0	0	1	1	6	8	1	0	1	8	10	57
05:15 PM	12	42	0	1	55	0	0	0	0	0	0	4	1	7	12	4	0	2	0	6	73
05:30 PM	7	49	0	2	58	0	0	0	0	0	0	8	0	7	15	1	0	3	1	5	78
05:45 PM	13	48	2	13	76	0	0	0	0	0	0	6	1	13	20	3	0	4	6	13	109
Total	40	168	2	18	228	0	0	0	0	0	0	19	3	33	55	9	0	10	15	34	317
Grand Total	85	296	6	28	415	0	0	0	0	0	0	39	7	45	91	17	0	15	22	54	560
Apprch %	20.5	71.3	1.4	6.7		0	0	0	0	0	0	42.9	7.7	49.5		31.5	0	27.8	40.7		
Total %	15.2	52.9	1.1	5	74.1	0	0	0	0	0	0	7	1.2	8	16.2	3	0	2.7	3.9	9.6	

Start Time	SHOWERS DR Southbound				Westbound				SHOWERS DR Northbound				PACCHETTI WAY Eastbound				Int. Total
	Right	Thru	Left	App. Total	Right	Thru	Left	App. Total	Right	Thru	Left	App. Total	Right	Thru	Left	App. Total	
Peak Hour Analysis From 04:00 PM to 05:45 PM - Peak 1 of 1																	
Peak Hour for Entire Intersection Begins at 05:00 PM																	
05:00 PM	8	29	0	37	0	0	0	0	0	1	1	2	1	0	1	2	41
05:15 PM	12	42	0	54	0	0	0	0	0	4	1	5	4	0	2	6	65
05:30 PM	7	49	0	56	0	0	0	0	0	8	0	8	1	0	3	4	68
05:45 PM	13	48	2	63	0	0	0	0	0	6	1	7	3	0	4	7	77
Total Volume	40	168	2	210	0	0	0	0	0	19	3	22	9	0	10	19	251
% App. Total	19	80	1		0	0	0		0	86.4	13.6		47.4	0	52.6		
PHF	.769	.857	.250	.833	.000	.000	.000	.000	.000	.594	.750	.688	.563	.000	.625	.679	.815

Traffic Data Service

Campbell, CA

(408) 377-2988

tdsbay@cs.com

File Name : 24PM FINAL

Site Code : 00000024

Start Date : 5/22/2013

Page No : 2

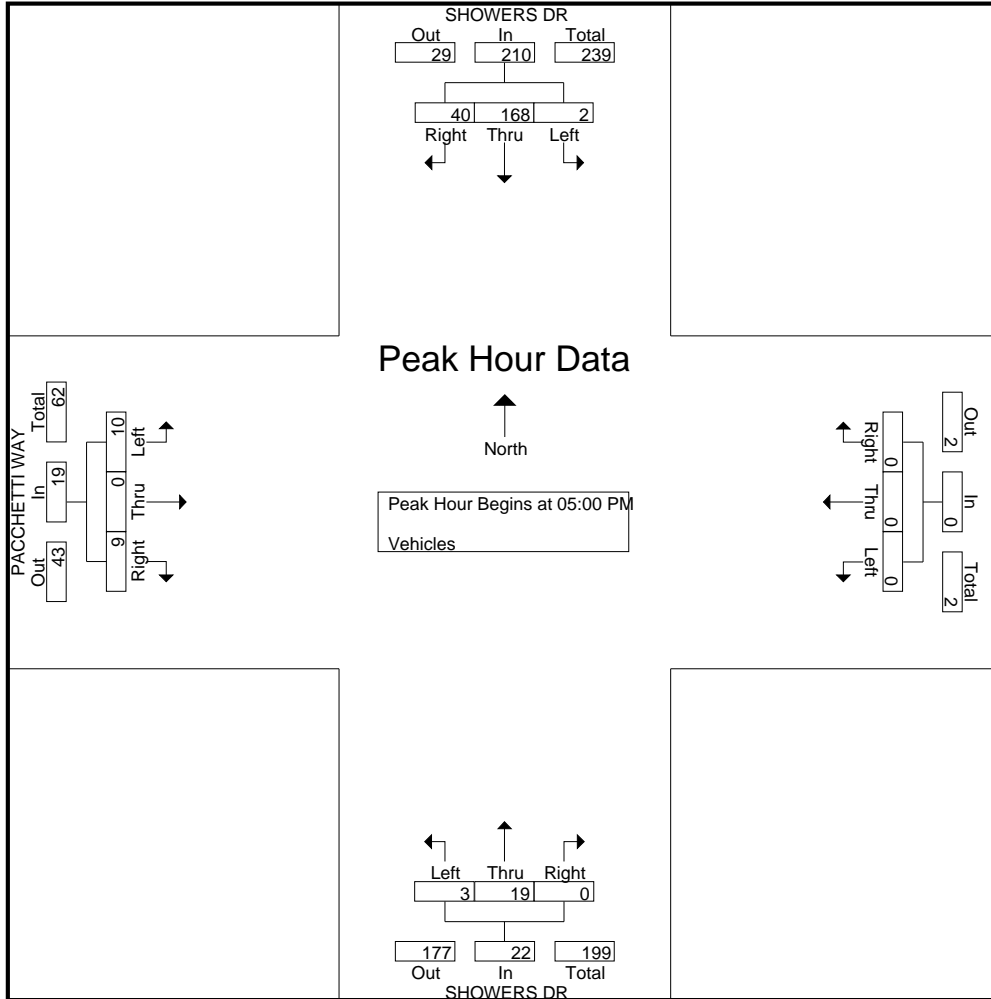

Traffic Data Service

Campbell, CA
 (408) 377-2988
 tdsbay@cs.com

File Name : 24PM FINAL
 Site Code : 00000024
 Start Date : 5/22/2013
 Page No : 1

Groups Printed- Bikes

Start Time	SHOWERS DR Southbound					Westbound					SHOWERS DR Northbound					PACCHETTI WAY Eastbound					Int. Total
	Right	Thru	Left	Peds	App. Total	Right	Thru	Left	Peds	App. Total	Right	Thru	Left	Peds	App. Total	Right	Thru	Left	Peds	App. Total	
04:00 PM	2	0	0	0	2	0	0	0	0	0	0	0	0	0	0	0	0	1	0	1	3
04:15 PM	1	0	0	0	1	0	0	0	0	0	0	0	0	0	0	0	0	0	0	0	1
04:30 PM	0	2	0	0	2	0	0	0	0	0	0	0	0	0	0	0	0	0	0	0	2
04:45 PM	0	0	0	0	0	0	0	0	0	0	0	1	0	0	1	0	0	0	0	0	1
Total	3	2	0	0	5	0	0	0	0	0	0	1	0	1	0	0	0	1	0	1	7
05:00 PM	0	1	0	0	1	0	0	0	0	0	0	0	1	0	1	0	0	0	0	0	2
05:15 PM	1	0	0	0	1	0	0	0	0	0	0	0	0	0	0	0	0	0	0	0	1
05:30 PM	1	1	0	0	2	0	0	0	0	0	0	1	0	0	1	0	0	1	0	1	4
05:45 PM	0	4	0	0	4	0	0	0	0	0	0	0	0	0	0	0	0	0	0	0	4
Total	2	6	0	0	8	0	0	0	0	0	0	1	1	0	2	0	0	1	0	1	11
Grand Total	5	8	0	0	13	0	0	0	0	0	0	2	1	0	3	0	0	2	0	2	18
Apprch %	38.5	61.5	0	0		0	0	0	0		0	66.7	33.3	0		0	0	100	0		
Total %	27.8	44.4	0	0	72.2	0	0	0	0	0	0	11.1	5.6	0	16.7	0	0	11.1	0	11.1	

Start Time	SHOWERS DR Southbound					Westbound					SHOWERS DR Northbound					PACCHETTI WAY Eastbound					Int. Total
	Right	Thru	Left	Peds	App. Total	Right	Thru	Left	Peds	App. Total	Right	Thru	Left	Peds	App. Total	Right	Thru	Left	Peds	App. Total	
05:00 PM	0	1	0	0	1	0	0	0	0	0	0	0	1	1	0	0	0	0	0	0	2
05:15 PM	1	0	0	0	1	0	0	0	0	0	0	0	0	0	0	0	0	0	0	0	1
05:30 PM	1	1	0	0	2	0	0	0	0	0	0	1	0	1	0	0	0	1	0	1	4
05:45 PM	0	4	0	0	4	0	0	0	0	0	0	0	0	0	0	0	0	0	0	0	4
Total Volume	2	6	0	0	8	0	0	0	0	0	0	1	1	2	0	0	1	1	0	1	11
% App. Total	25	75	0	0		0	0	0	0		0	50	50		0	0	100	0			
PHF	.500	.375	.000	.000	.500	.000	.000	.000	.000	.000	.000	.250	.250	.500	.000	.000	.250	.250	.000	.250	.688

Peak Hour Analysis From 04:00 PM to 05:45 PM - Peak 1 of 1

Peak Hour for Entire Intersection Begins at 05:00 PM

Traffic Data Service

Campbell, CA
(408) 377-2988
tdsbay@cs.com

File Name : 24PM FINAL
Site Code : 00000024
Start Date : 5/22/2013
Page No : 2

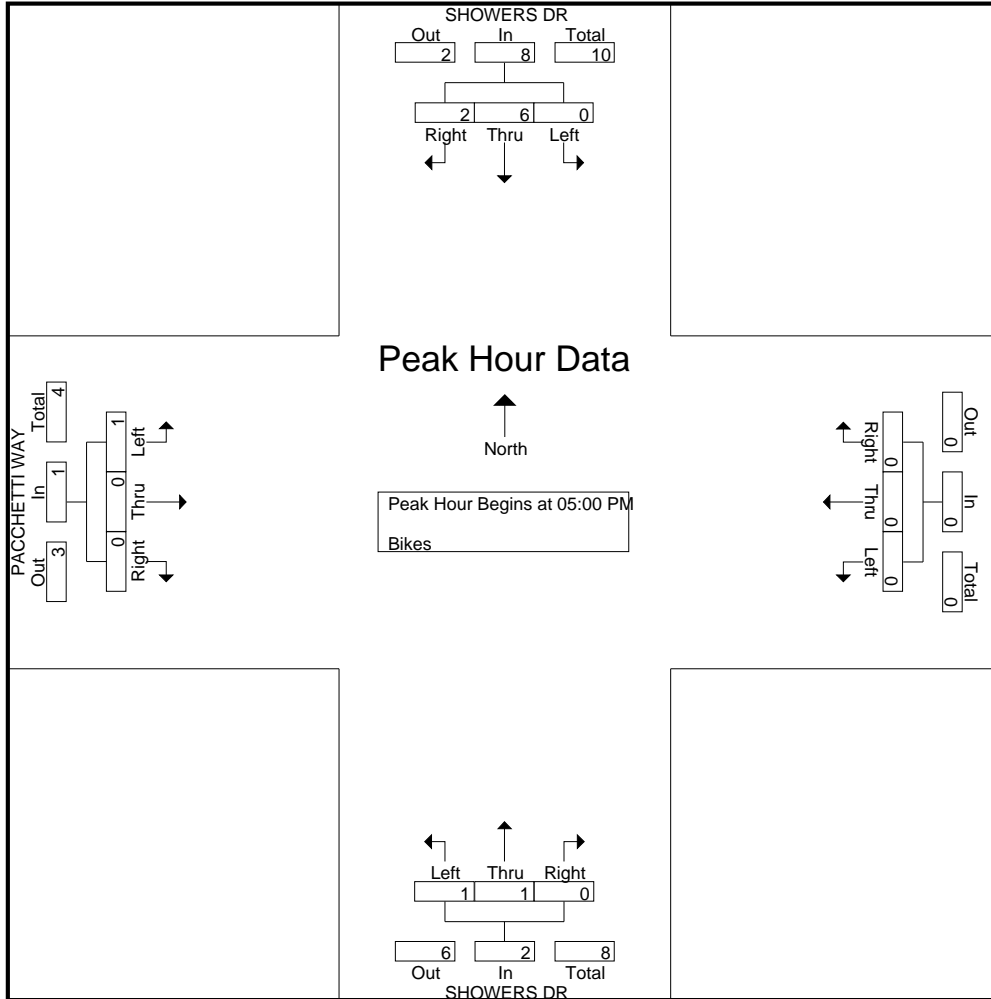

Traffic Data Service

Campbell, CA
 (408) 377-2988
 tdsbay@cs.com

File Name : 89AM FINAL
 Site Code : 00000089
 Start Date : 6/4/2013
 Page No : 1

Groups Printed- Vehicles

Start Time	N. RENGSTORFF AVE Southbound					CENTRAL EXPY Westbound					S. RENGSTORFF AVE Northbound					CENTRAL EXPY Eastbound					Int. Total
	Right	Thru	Left	Peds	App. Total	Right	Thru	Left	Peds	App. Total	Right	Thru	Left	Peds	App. Total	Right	Thru	Left	Peds	App. Total	
07:00 AM	11	37	3	2	53	15	205	20	9	249	6	56	24	0	86	5	58	5	3	71	459
07:15 AM	8	41	9	2	60	37	261	21	11	330	18	63	23	0	104	5	75	9	5	94	588
07:30 AM	12	42	5	2	61	43	378	34	12	467	17	124	35	1	177	9	100	8	6	123	828
07:45 AM	10	73	8	1	92	50	315	36	3	404	22	112	41	2	177	11	145	22	2	180	853
Total	41	193	25	7	266	145	1159	111	35	1450	63	355	123	3	544	30	378	44	16	468	2728
08:00 AM	21	66	14	0	101	76	343	25	6	450	16	103	28	3	150	26	153	19	10	208	909
08:15 AM	16	60	11	0	87	49	337	38	5	429	14	118	67	0	199	29	168	31	4	232	947
08:30 AM	17	44	5	0	66	57	351	36	8	452	30	128	44	0	202	35	227	19	5	286	1006
08:45 AM	15	76	21	0	112	66	318	31	5	420	32	140	39	0	211	23	165	28	5	221	964
Total	69	246	51	0	366	248	1349	130	24	1751	92	489	178	3	762	113	713	97	24	947	3826
Grand Total	110	439	76	7	632	393	2508	241	59	3201	155	844	301	6	1306	143	1091	141	40	1415	6554
Apprch %	17.4	69.5	12	1.1		12.3	78.4	7.5	1.8		11.9	64.6	23	0.5		10.1	77.1	10	2.8		
Total %	1.7	6.7	1.2	0.1	9.6	6	38.3	3.7	0.9	48.8	2.4	12.9	4.6	0.1	19.9	2.2	16.6	2.2	0.6	21.6	

Start Time	N. RENGSTORFF AVE Southbound				CENTRAL EXPY Westbound				S. RENGSTORFF AVE Northbound				CENTRAL EXPY Eastbound				Int. Total
	Right	Thru	Left	App. Total	Right	Thru	Left	App. Total	Right	Thru	Left	App. Total	Right	Thru	Left	App. Total	
Peak Hour Analysis From 07:00 AM to 08:45 AM - Peak 1 of 1																	
Peak Hour for Entire Intersection Begins at 08:00 AM																	
08:00 AM	21	66	14	101	76	343	25	444	16	103	28	147	26	153	19	198	890
08:15 AM	16	60	11	87	49	337	38	424	14	118	67	199	29	168	31	228	938
08:30 AM	17	44	5	66	57	351	36	444	30	128	44	202	35	227	19	281	993
08:45 AM	15	76	21	112	66	318	31	415	32	140	39	211	23	165	28	216	954
Total Volume	69	246	51	366	248	1349	130	1727	92	489	178	759	113	713	97	923	3775
% App. Total	18.9	67.2	13.9		14.4	78.1	7.5		12.1	64.4	23.5		12.2	77.2	10.5		
PHF	.821	.809	.607	.817	.816	.961	.855	.972	.719	.873	.664	.899	.807	.785	.782	.821	.950

Traffic Data Service

Campbell, CA
 (408) 377-2988
 tdsbay@cs.com

File Name : 89AM FINAL
 Site Code : 00000089
 Start Date : 6/4/2013
 Page No : 2

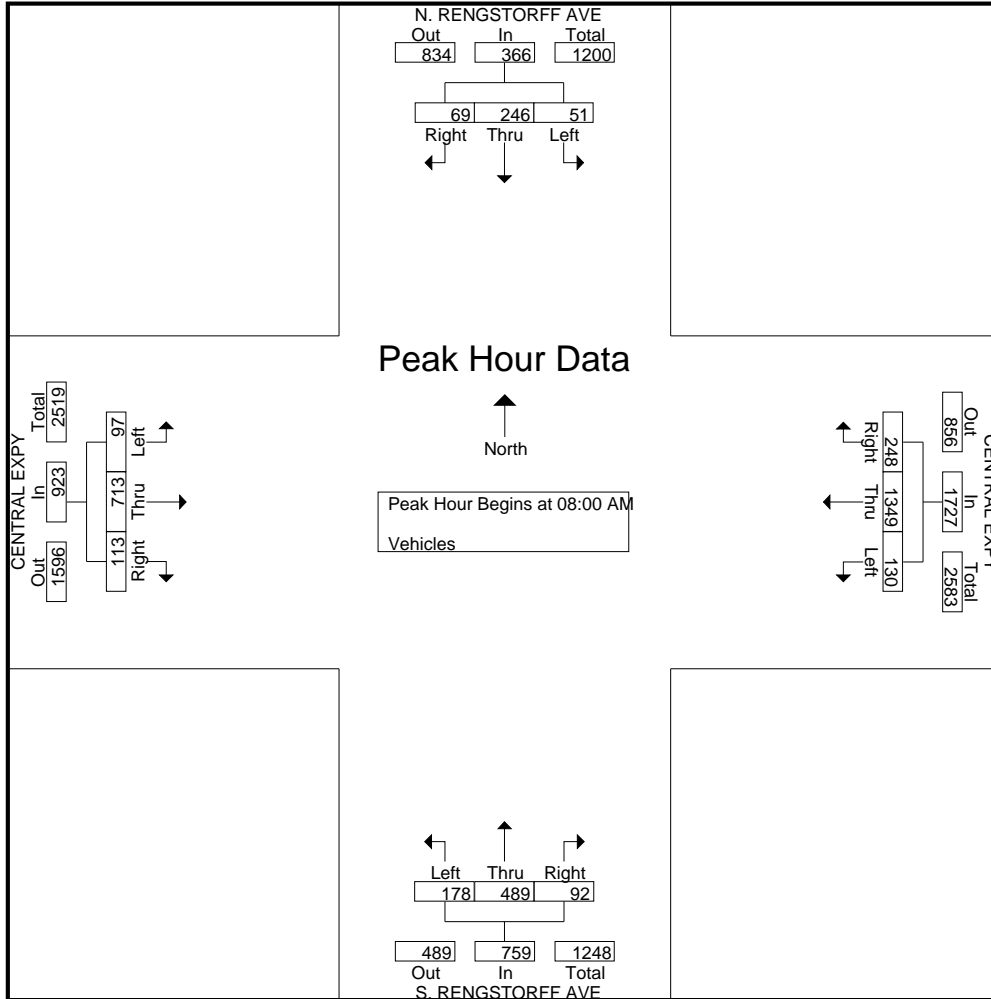

Traffic Data Service

Campbell, CA
 (408) 377-2988
 tdsbay@cs.com

File Name : 89AM FINAL
 Site Code : 00000089
 Start Date : 6/4/2013
 Page No : 1

Groups Printed- Bikes

Start Time	N. RENGSTORFF AVE Southbound					CENTRAL EXPY Westbound					S. RENGSTORFF AVE Northbound					CENTRAL EXPY Eastbound					Int. Total
	Right	Thru	Left	Peds	App. Total	Right	Thru	Left	Peds	App. Total	Right	Thru	Left	Peds	App. Total	Right	Thru	Left	Peds	App. Total	
07:00 AM	0	0	0	0	0	0	3	0	0	3	0	2	1	0	3	0	3	0	0	3	9
07:15 AM	0	1	0	0	1	0	3	0	0	3	0	5	0	0	5	0	2	0	0	2	11
07:30 AM	0	0	0	0	0	0	1	0	0	1	0	6	1	0	7	0	1	0	0	1	9
07:45 AM	0	0	0	0	0	0	2	0	0	2	0	2	1	0	3	0	0	0	0	0	5
Total	0	1	0	0	1	0	9	0	0	9	0	15	3	0	18	0	6	0	0	6	34
08:00 AM	0	3	0	0	3	0	0	1	0	1	0	7	0	0	7	0	4	0	0	4	15
08:15 AM	1	0	0	0	1	0	5	2	0	7	1	11	0	0	12	0	0	0	0	0	20
08:30 AM	0	0	0	0	0	0	2	0	0	2	0	13	1	0	14	1	4	0	0	5	21
08:45 AM	0	1	0	0	1	0	4	1	0	5	0	13	0	0	13	1	4	0	0	5	24
Total	1	4	0	0	5	0	11	4	0	15	1	44	1	0	46	2	12	0	0	14	80
Grand Total	1	5	0	0	6	0	20	4	0	24	1	59	4	0	64	2	18	0	0	20	114
Apprch %	16.7	83.3	0	0		0	83.3	16.7	0		1.6	92.2	6.2	0		10	90	0	0		
Total %	0.9	4.4	0	0	5.3	0	17.5	3.5	0	21.1	0.9	51.8	3.5	0	56.1	1.8	15.8	0	0	17.5	

Start Time	N. RENGSTORFF AVE Southbound				CENTRAL EXPY Westbound				S. RENGSTORFF AVE Northbound				CENTRAL EXPY Eastbound				Int. Total
	Right	Thru	Left	App. Total	Right	Thru	Left	App. Total	Right	Thru	Left	App. Total	Right	Thru	Left	App. Total	
08:00 AM	0	3	0	3	0	0	1	1	0	7	0	7	0	4	0	4	15
08:15 AM	1	0	0	1	0	5	2	7	1	11	0	12	0	0	0	0	20
08:30 AM	0	0	0	0	0	2	0	2	0	13	1	14	1	4	0	5	21
08:45 AM	0	1	0	1	0	4	1	5	0	13	0	13	1	4	0	5	24
Total Volume	1	4	0	5	0	11	4	15	1	44	1	46	2	12	0	14	80
% App. Total	20	80	0		0	73.3	26.7		2.2	95.7	2.2		14.3	85.7	0		
PHF	.250	.333	.000	.417	.000	.550	.500	.536	.250	.846	.250	.821	.500	.750	.000	.700	.833

Peak Hour Analysis From 07:00 AM to 08:45 AM - Peak 1 of 1

Peak Hour for Entire Intersection Begins at 08:00 AM

Traffic Data Service

Campbell, CA
(408) 377-2988
tdsbay@cs.com

File Name : 89AM FINAL
Site Code : 00000089
Start Date : 6/4/2013
Page No : 2

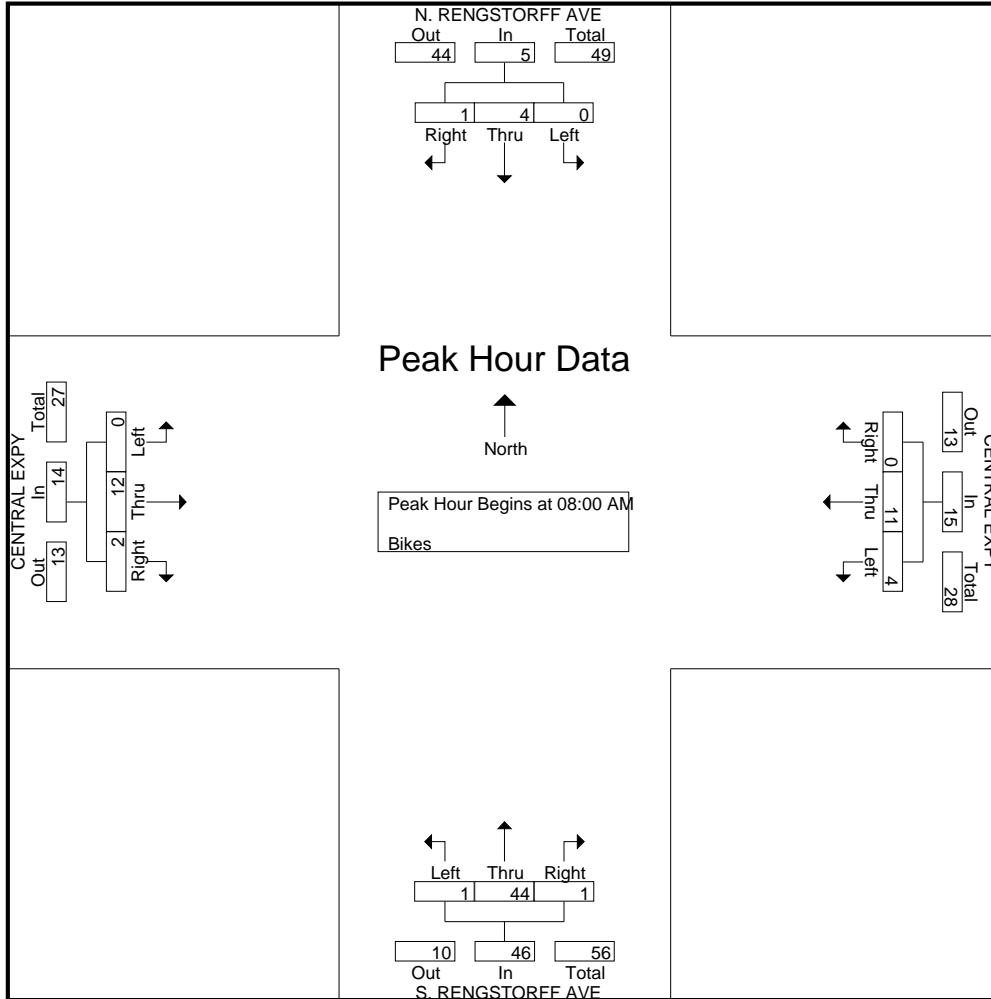

Traffic Data Service

Campbell, CA
 (408) 377-2988
 tdsbay@cs.com

File Name : 89PM FINAL
 Site Code : 00000089
 Start Date : 6/4/2013
 Page No : 1

Groups Printed- Vehicles

Start Time	N. RENGSTORFF AVE Southbound					CENTRAL EXPY Westbound					S. RENGSTORFF AVE Northbound					CENTRAL EXPY Eastbound					Int. Total
	Right	Thru	Left	Peds	App. Total	Right	Thru	Left	Peds	App. Total	Right	Thru	Left	Peds	App. Total	Right	Thru	Left	Peds	App. Total	
04:00 PM	14	78	23	1	116	21	173	24	3	221	33	68	16	0	117	18	243	26	6	293	747
04:15 PM	18	126	35	0	179	21	171	25	1	218	32	94	27	1	154	30	249	24	4	307	858
04:30 PM	15	96	27	6	144	34	188	25	4	251	33	86	30	1	150	14	323	21	9	367	912
04:45 PM	6	121	32	7	166	29	203	37	7	276	40	73	18	1	132	22	349	31	10	412	986
Total	53	421	117	14	605	105	735	111	15	966	138	321	91	3	553	84	1164	102	29	1379	3503
05:00 PM	7	125	27	3	162	30	233	40	5	308	28	77	17	2	124	39	302	22	16	379	973
05:15 PM	17	124	36	4	181	34	231	46	12	323	26	92	23	2	143	29	275	18	10	332	979
05:30 PM	16	114	49	8	187	31	274	34	3	342	28	67	33	2	130	38	323	21	22	404	1063
05:45 PM	8	98	43	5	154	37	267	31	19	354	40	45	17	0	102	39	322	29	14	404	1014
Total	48	461	155	20	684	132	1005	151	39	1327	122	281	90	6	499	145	1222	90	62	1519	4029
Grand Total	101	882	272	34	1289	237	1740	262	54	2293	260	602	181	9	1052	229	2386	192	91	2898	7532
Apprch %	7.8	68.4	21.1	2.6		10.3	75.9	11.4	2.4		24.7	57.2	17.2	0.9		7.9	82.3	6.6	3.1		
Total %	1.3	11.7	3.6	0.5	17.1	3.1	23.1	3.5	0.7	30.4	3.5	8	2.4	0.1	14	3	31.7	2.5	1.2	38.5	

Start Time	N. RENGSTORFF AVE Southbound				CENTRAL EXPY Westbound				S. RENGSTORFF AVE Northbound				CENTRAL EXPY Eastbound				Int. Total
	Right	Thru	Left	App. Total	Right	Thru	Left	App. Total	Right	Thru	Left	App. Total	Right	Thru	Left	App. Total	
Peak Hour Analysis From 04:00 PM to 05:45 PM - Peak 1 of 1																	
Peak Hour for Entire Intersection Begins at 05:00 PM																	
05:00 PM	7	125	27	159	30	233	40	303	28	77	17	122	39	302	22	363	947
05:15 PM	17	124	36	177	34	231	46	311	26	92	23	141	29	275	18	322	951
05:30 PM	16	114	49	179	31	274	34	339	28	67	33	128	38	323	21	382	1028
05:45 PM	8	98	43	149	37	267	31	335	40	45	17	102	39	322	29	390	976
Total Volume	48	461	155	664	132	1005	151	1288	122	281	90	493	145	1222	90	1457	3902
% App. Total	7.2	69.4	23.3		10.2	78	11.7		24.7	57	18.3		10	83.9	6.2		
PHF	.706	.922	.791	.927	.892	.917	.821	.950	.763	.764	.682	.874	.929	.946	.776	.934	.949

Traffic Data Service

Campbell, CA
 (408) 377-2988
 tdsbay@cs.com

File Name : 89PM FINAL
 Site Code : 00000089
 Start Date : 6/4/2013
 Page No : 2

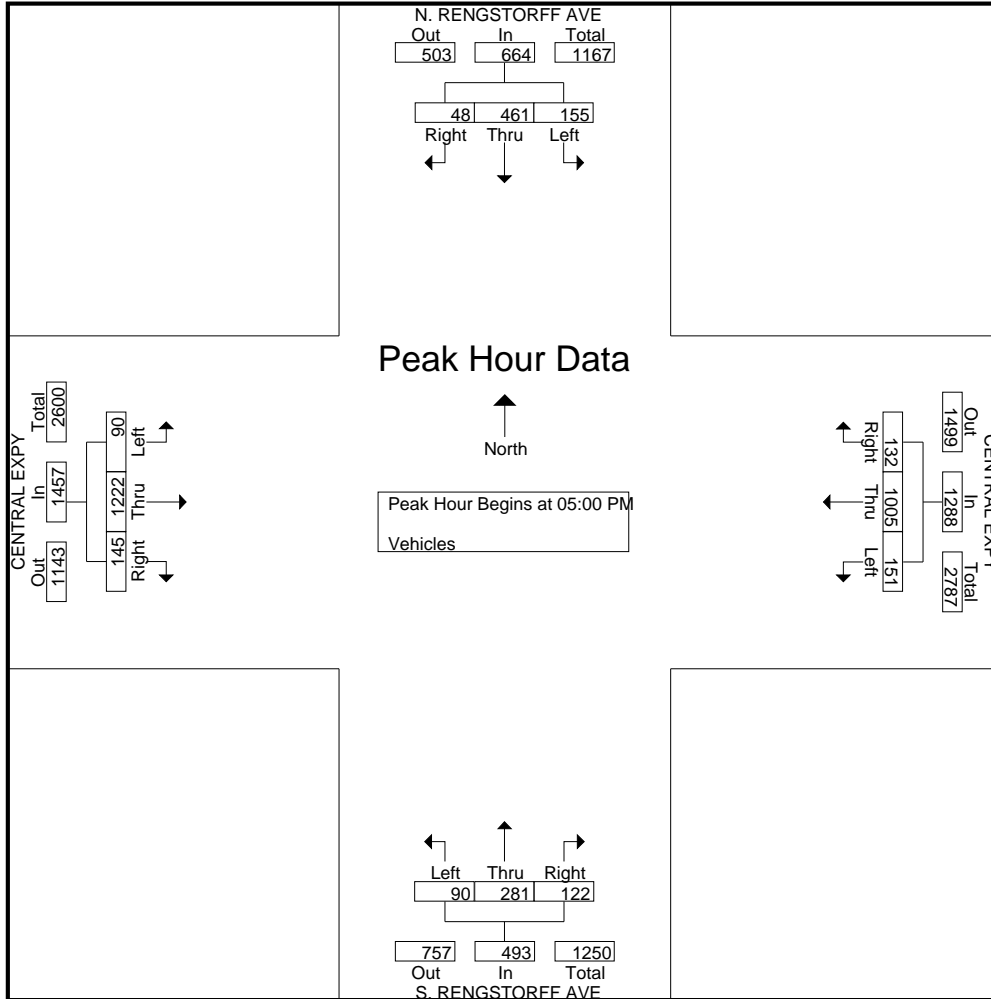

Traffic Data Service

Campbell, CA
 (408) 377-2988
 tdsbay@cs.com

File Name : 89PM FINAL
 Site Code : 00000089
 Start Date : 6/4/2013
 Page No : 1

Groups Printed- Bikes

Start Time	N. RENGSTORFF AVE Southbound					CENTRAL EXPY Westbound					S. RENGSTORFF AVE Northbound					CENTRAL EXPY Eastbound					Int. Total
	Right	Thru	Left	Peds	App. Total	Right	Thru	Left	Peds	App. Total	Right	Thru	Left	Peds	App. Total	Right	Thru	Left	Peds	App. Total	
04:00 PM	0	0	0	0	0	0	0	0	0	0	0	3	0	0	3	0	0	0	0	0	0
04:15 PM	0	1	0	0	1	0	0	0	0	0	0	1	0	0	1	0	0	0	0	0	0
04:30 PM	0	4	0	0	4	0	2	0	0	2	0	1	0	0	1	0	3	0	0	3	10
04:45 PM	0	5	0	0	5	0	2	0	0	2	0	2	0	0	2	0	1	0	0	1	10
Total	0	10	0	0	10	0	4	0	0	4	0	7	0	0	7	0	4	0	0	4	25
05:00 PM	0	6	0	0	6	0	2	0	0	2	0	1	0	0	1	0	0	0	0	0	9
05:15 PM	0	3	0	0	3	0	1	0	0	1	0	3	0	0	3	1	3	0	0	4	11
05:30 PM	0	5	0	0	5	0	2	0	0	2	0	0	0	0	0	0	1	0	0	1	8
05:45 PM	0	7	0	0	7	0	2	0	0	2	0	5	0	0	5	0	1	0	0	1	15
Total	0	21	0	0	21	0	7	0	0	7	0	9	0	0	9	1	5	0	0	6	43
Grand Total	0	31	0	0	31	0	11	0	0	11	0	16	0	0	16	1	9	0	0	10	68
Apprch %	0	100	0	0		0	100	0	0		0	100	0	0		10	90	0	0		
Total %	0	45.6	0	0	45.6	0	16.2	0	0	16.2	0	23.5	0	0	23.5	1.5	13.2	0	0	14.7	

Start Time	N. RENGSTORFF AVE Southbound				CENTRAL EXPY Westbound				S. RENGSTORFF AVE Northbound				CENTRAL EXPY Eastbound				Int. Total
	Right	Thru	Left	App. Total	Right	Thru	Left	App. Total	Right	Thru	Left	App. Total	Right	Thru	Left	App. Total	
05:00 PM	0	6	0	6	0	2	0	2	0	1	0	1	0	0	0	0	9
05:15 PM	0	3	0	3	0	1	0	1	0	3	0	3	1	3	0	4	11
05:30 PM	0	5	0	5	0	2	0	2	0	0	0	0	0	1	0	1	8
05:45 PM	0	7	0	7	0	2	0	2	0	5	0	5	0	1	0	1	15
Total Volume	0	21	0	21	0	7	0	7	0	9	0	9	1	5	0	6	43
% App. Total	0	100	0		0	100	0		0	100	0		16.7	83.3	0		
PHF	.000	.750	.000	.750	.000	.875	.000	.875	.000	.450	.000	.450	.250	.417	.000	.375	.717

Peak Hour Analysis From 04:00 PM to 05:45 PM - Peak 1 of 1

Peak Hour for Entire Intersection Begins at 05:00 PM

Traffic Data Service

Campbell, CA

(408) 377-2988

tdsbay@cs.com

File Name : 89PM FINAL

Site Code : 00000089

Start Date : 6/4/2013

Page No : 2

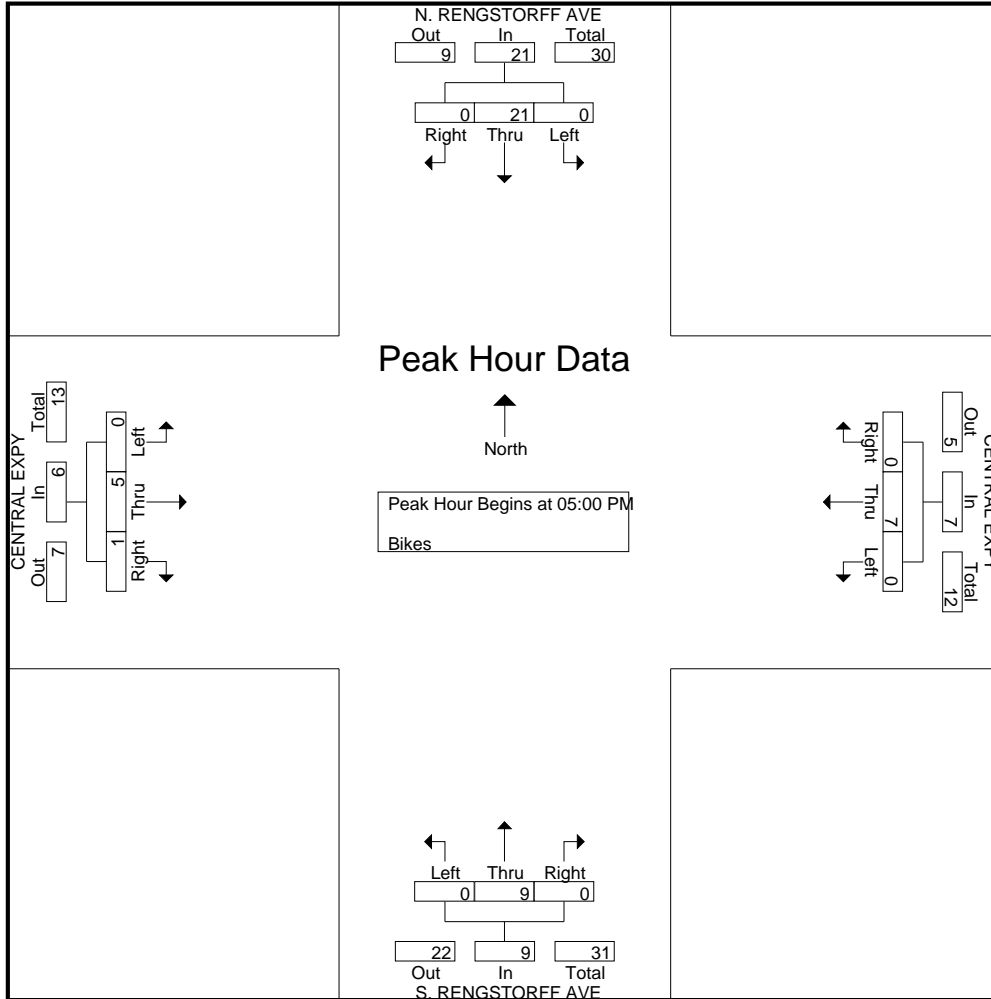

Traffic Data Service

Campbell, CA
 (408) 377-2988
 tdsbay@cs.com

File Name : 90AM FINAL
 Site Code : 00000090
 Start Date : 6/5/2013
 Page No : 1

Groups Printed- Vehicles

Start Time	MOFFETT BLVD Southbound					CENTRAL EXPY Westbound					CASTRO ST Northbound					CENTRAL EXPY Eastbound					Int. Total
	Right	Thru	Left	Peds	App. Total	Right	Thru	Left	Peds	App. Total	Right	Thru	Left	Peds	App. Total	Right	Thru	Left	Peds	App. Total	
07:00 AM	25	25	0	1	51	7	193	18	15	233	6	21	29	8	64	15	68	8	6	97	445
07:15 AM	33	17	3	5	58	17	297	15	16	345	6	36	27	3	72	11	93	9	5	118	593
07:30 AM	47	18	0	6	71	27	417	26	24	494	9	34	32	5	80	16	118	9	3	146	791
07:45 AM	37	22	6	20	85	24	359	27	54	464	20	33	44	19	116	21	144	31	18	214	879
Total	142	82	9	32	265	75	1266	86	109	1536	41	124	132	35	332	63	423	57	32	575	2708
08:00 AM	42	40	5	7	94	34	363	32	42	471	17	45	44	8	114	29	174	29	11	243	922
08:15 AM	27	19	3	4	53	42	346	33	32	453	24	65	56	8	153	41	171	25	14	251	910
08:30 AM	62	37	14	6	119	35	360	29	21	445	17	59	42	11	129	35	257	36	13	341	1034
08:45 AM	43	37	16	15	111	37	294	34	49	414	31	78	51	9	169	44	215	28	20	307	1001
Total	174	133	38	32	377	148	1363	128	144	1783	89	247	193	36	565	149	817	118	58	1142	3867
Grand Total	316	215	47	64	642	223	2629	214	253	3319	130	371	325	71	897	212	1240	175	90	1717	6575
Apprch %	49.2	33.5	7.3	10		6.7	79.2	6.4	7.6		14.5	41.4	36.2	7.9		12.3	72.2	10.2	5.2		
Total %	4.8	3.3	0.7	1	9.8	3.4	40	3.3	3.8	50.5	2	5.6	4.9	1.1	13.6	3.2	18.9	2.7	1.4	26.1	

Start Time	MOFFETT BLVD Southbound				CENTRAL EXPY Westbound				CASTRO ST Northbound				CENTRAL EXPY Eastbound				Int. Total
	Right	Thru	Left	App. Total	Right	Thru	Left	App. Total	Right	Thru	Left	App. Total	Right	Thru	Left	App. Total	
Peak Hour Analysis From 07:00 AM to 08:45 AM - Peak 1 of 1																	
Peak Hour for Entire Intersection Begins at 08:00 AM																	
08:00 AM	42	40	5	87	34	363	32	429	17	45	44	106	29	174	29	232	854
08:15 AM	27	19	3	49	42	346	33	421	24	65	56	145	41	171	25	237	852
08:30 AM	62	37	14	113	35	360	29	424	17	59	42	118	35	257	36	328	983
08:45 AM	43	37	16	96	37	294	34	365	31	78	51	160	44	215	28	287	908
Total Volume	174	133	38	345	148	1363	128	1639	89	247	193	529	149	817	118	1084	3597
% App. Total	50.4	38.6	11		9	83.2	7.8		16.8	46.7	36.5		13.7	75.4	10.9		
PHF	.702	.831	.594	.763	.881	.939	.941	.955	.718	.792	.862	.827	.847	.795	.819	.826	.915

Traffic Data Service

Campbell, CA
(408) 377-2988
tdsbay@cs.com

File Name : 90AM FINAL
Site Code : 00000090
Start Date : 6/5/2013
Page No : 2

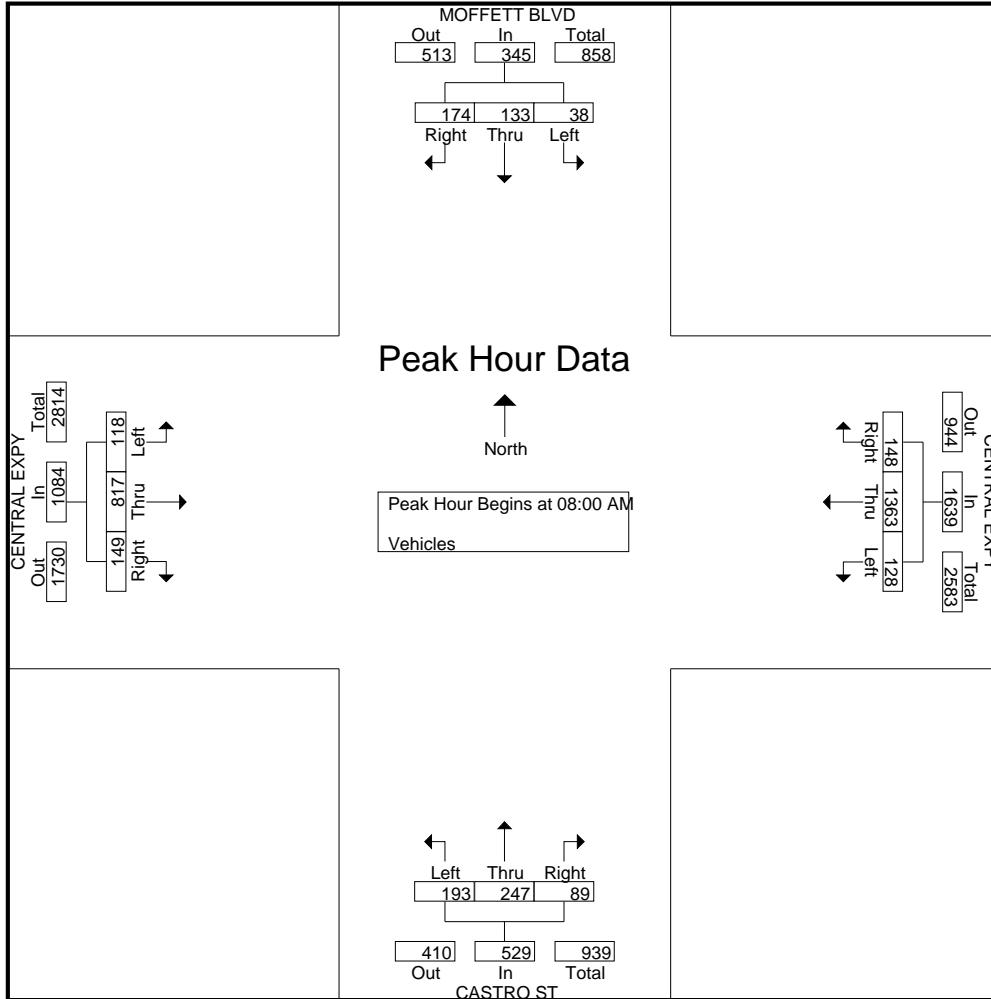

Traffic Data Service

Campbell, CA
 (408) 377-2988
 tdsbay@cs.com

File Name : 90AM FINAL
 Site Code : 00000090
 Start Date : 6/5/2013
 Page No : 1

Groups Printed- Bikes

Start Time	MOFFETT BLVD Southbound					CENTRAL EXPY Westbound					CASTRO ST Northbound					CENTRAL EXPY Eastbound					Int. Total
	Right	Thru	Left	Peds	App. Total	Right	Thru	Left	Peds	App. Total	Right	Thru	Left	Peds	App. Total	Right	Thru	Left	Peds	App. Total	
07:00 AM	0	1	0	0	1	0	0	0	0	0	2	4	2	0	8	0	2	0	0	2	11
07:15 AM	0	1	0	0	1	0	0	0	0	0	0	6	0	0	6	0	1	0	0	1	8
07:30 AM	0	0	0	0	0	0	1	0	0	1	2	8	1	0	11	1	4	0	0	5	17
07:45 AM	0	1	0	0	1	0	0	0	0	0	6	8	0	0	14	0	1	0	0	1	16
Total	0	3	0	0	3	0	1	0	0	1	10	26	3	0	39	1	8	0	0	9	52
08:00 AM	0	2	0	0	2	0	1	0	0	1	2	9	2	0	13	0	0	0	0	0	16
08:15 AM	1	0	0	0	1	0	0	0	0	0	1	6	1	0	8	1	0	0	0	1	10
08:30 AM	0	0	0	0	0	0	1	0	0	1	1	8	0	0	9	1	1	0	0	2	12
08:45 AM	1	1	0	0	2	0	0	0	0	0	3	15	1	0	19	1	1	0	0	2	23
Total	2	3	0	0	5	0	2	0	0	2	7	38	4	0	49	3	2	0	0	5	61
Grand Total	2	6	0	0	8	0	3	0	0	3	17	64	7	0	88	4	10	0	0	14	113
Apprch %	25	75	0	0		0	100	0	0		19.3	72.7	8	0		28.6	71.4	0	0		
Total %	1.8	5.3	0	0	7.1	0	2.7	0	0	2.7	15	56.6	6.2	0	77.9	3.5	8.8	0	0	12.4	

Start Time	MOFFETT BLVD Southbound				CENTRAL EXPY Westbound				CASTRO ST Northbound				CENTRAL EXPY Eastbound				Int. Total
	Right	Thru	Left	App. Total	Right	Thru	Left	App. Total	Right	Thru	Left	App. Total	Right	Thru	Left	App. Total	
08:00 AM	0	2	0	2	0	1	0	1	2	9	2	13	0	0	0	0	16
08:15 AM	1	0	0	1	0	0	0	0	1	6	1	8	1	0	0	1	10
08:30 AM	0	0	0	0	0	1	0	1	1	8	0	9	1	1	0	2	12
08:45 AM	1	1	0	2	0	0	0	0	3	15	1	19	1	1	0	2	23
Total Volume	2	3	0	5	0	2	0	2	7	38	4	49	3	2	0	5	61
% App. Total	40	60	0		0	100	0		14.3	77.6	8.2		60	40	0		
PHF	.500	.375	.000	.625	.000	.500	.000	.500	.583	.633	.500	.645	.750	.500	.000	.625	.663

Peak Hour Analysis From 07:00 AM to 08:45 AM - Peak 1 of 1

Peak Hour for Entire Intersection Begins at 08:00 AM

Traffic Data Service

Campbell, CA

(408) 377-2988

tdsbay@cs.com

File Name : 90AM FINAL

Site Code : 00000090

Start Date : 6/5/2013

Page No : 2

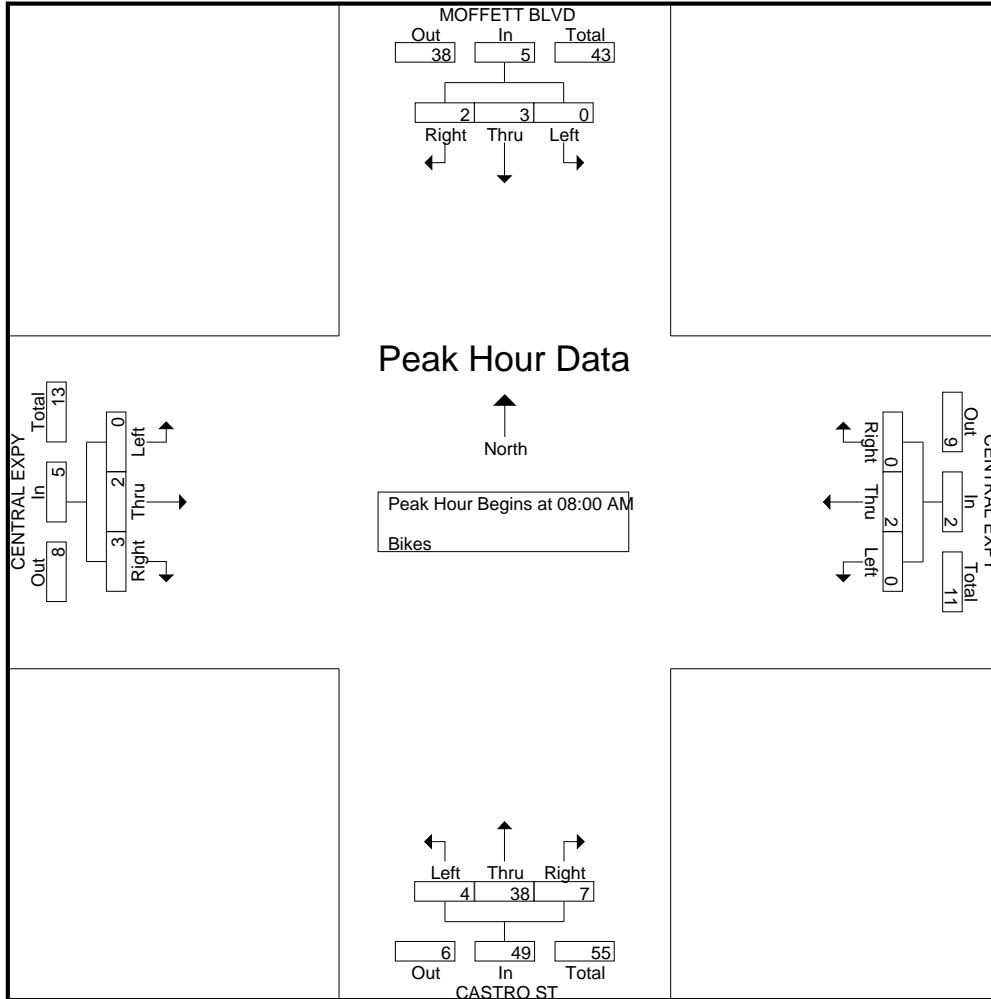

Traffic Data Service

Campbell, CA
 (408) 377-2988
 tdsbay@cs.com

File Name : 90PM FINAL
 Site Code : 00000090
 Start Date : 6/5/2013
 Page No : 1

Groups Printed- Vehicles

Start Time	MOFFETT BLVD Southbound					CENTRAL EXPY Westbound					CASTRO ST Northbound					CENTRAL EXPY Eastbound					Int. Total
	Right	Thru	Left	Peds	App. Total	Right	Thru	Left	Peds	App. Total	Right	Thru	Left	Peds	App. Total	Right	Thru	Left	Peds	App. Total	
04:00 PM	16	42	10	5	73	11	150	28	26	215	24	49	41	4	118	38	273	32	10	353	759
04:15 PM	27	50	8	4	89	14	162	36	24	236	22	65	43	17	147	48	289	30	19	386	858
04:30 PM	28	54	15	2	99	9	176	39	32	256	34	57	36	7	134	42	271	20	14	347	836
04:45 PM	19	41	4	13	77	13	254	39	40	346	30	51	24	12	117	60	375	39	8	482	1022
Total	90	187	37	24	338	47	742	142	122	1053	110	222	144	40	516	188	1208	121	51	1568	3475
05:00 PM	23	73	23	14	133	19	216	51	65	351	37	69	46	6	158	37	306	12	8	363	1005
05:15 PM	19	75	10	15	119	22	319	47	45	433	46	48	37	6	137	37	343	24	22	426	1115
05:30 PM	22	59	4	13	98	23	289	55	48	415	30	46	31	5	112	55	337	26	13	431	1056
05:45 PM	6	29	7	18	60	23	287	62	84	456	29	52	29	22	132	49	328	31	14	422	1070
Total	70	236	44	60	410	87	1111	215	242	1655	142	215	143	39	539	178	1314	93	57	1642	4246
Grand Total	160	423	81	84	748	134	1853	357	364	2708	252	437	287	79	1055	366	2522	214	108	3210	7721
Apprch %	21.4	56.6	10.8	11.2		4.9	68.4	13.2	13.4		23.9	41.4	27.2	7.5		11.4	78.6	6.7	3.4		
Total %	2.1	5.5	1	1.1	9.7	1.7	24	4.6	4.7	35.1	3.3	5.7	3.7	1	13.7	4.7	32.7	2.8	1.4	41.6	

Start Time	MOFFETT BLVD Southbound				CENTRAL EXPY Westbound				CASTRO ST Northbound				CENTRAL EXPY Eastbound				Int. Total
	Right	Thru	Left	App. Total	Right	Thru	Left	App. Total	Right	Thru	Left	App. Total	Right	Thru	Left	App. Total	
Peak Hour Analysis From 04:00 PM to 05:45 PM - Peak 1 of 1																	
Peak Hour for Entire Intersection Begins at 04:45 PM																	
04:45 PM	19	41	4	64	13	254	39	306	30	51	24	105	60	375	39	474	949
05:00 PM	23	73	23	119	19	216	51	286	37	69	46	152	37	306	12	355	912
05:15 PM	19	75	10	104	22	319	47	388	46	48	37	131	37	343	24	404	1027
05:30 PM	22	59	4	85	23	289	55	367	30	46	31	107	55	337	26	418	977
Total Volume	83	248	41	372	77	1078	192	1347	143	214	138	495	189	1361	101	1651	3865
% App. Total	22.3	66.7	11		5.7	80	14.3		28.9	43.2	27.9		11.4	82.4	6.1		
PHF	.902	.827	.446	.782	.837	.845	.873	.868	.777	.775	.750	.814	.788	.907	.647	.871	.941

Traffic Data Service

Campbell, CA
(408) 377-2988
tdsbay@cs.com

File Name : 90PM FINAL
Site Code : 00000090
Start Date : 6/5/2013
Page No : 2

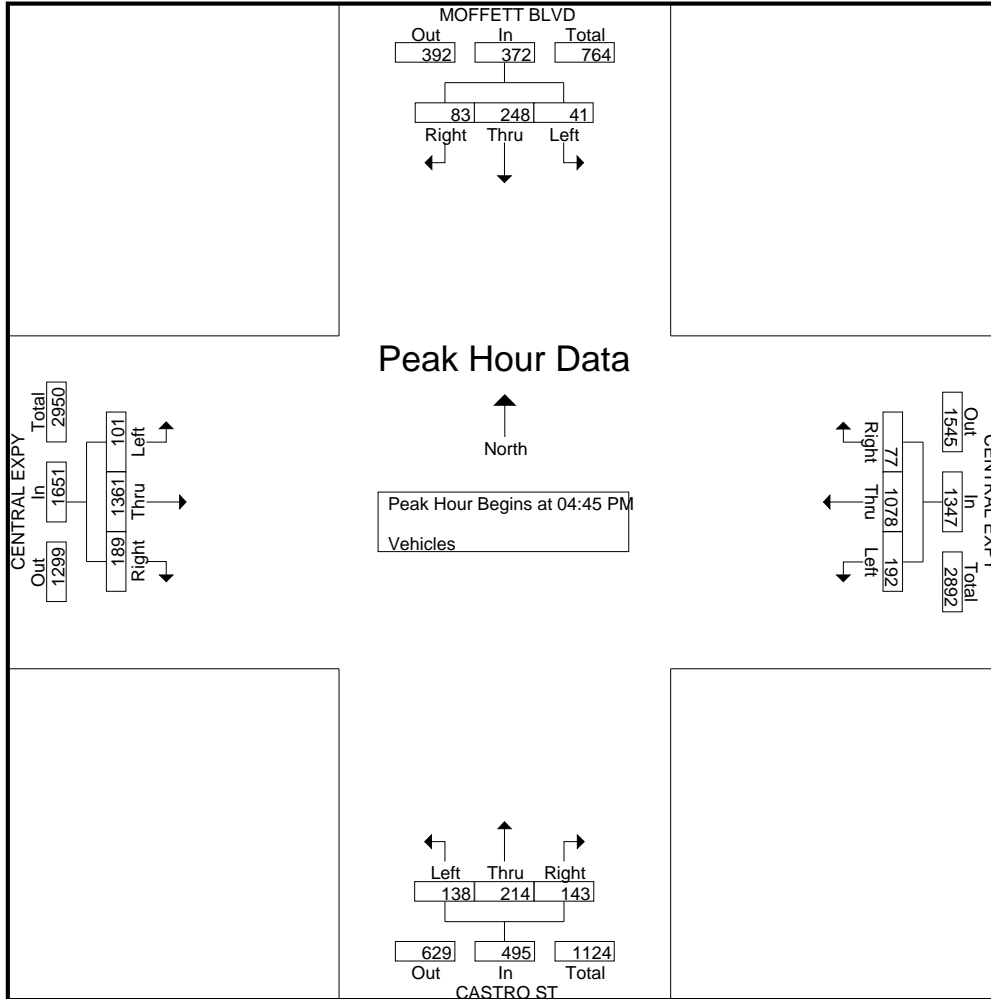

Traffic Data Service

Campbell, CA
(408) 377-2988
tdsbay@cs.com

File Name : 90PM FINAL
Site Code : 00000090
Start Date : 6/5/2013
Page No : 1

Groups Printed- Bikes

Start Time	MOFFETT BLVD Southbound					CENTRAL EXPY Westbound					CASTRO ST Northbound					CENTRAL EXPY Eastbound					Int. Total
	Right	Thru	Left	Peds	App. Total	Right	Thru	Left	Peds	App. Total	Right	Thru	Left	Peds	App. Total	Right	Thru	Left	Peds	App. Total	
04:00 PM	0	1	0	0	1	0	0	0	0	0	0	1	1	0	2	0	1	0	0	1	4
04:15 PM	0	5	0	0	5	0	0	1	0	1	0	8	0	0	8	0	0	0	0	0	14
04:30 PM	0	5	1	0	6	0	0	0	0	0	0	2	1	0	3	1	1	0	0	2	11
04:45 PM	1	4	0	0	5	1	3	0	0	4	0	2	0	0	2	0	1	0	0	1	12
Total	1	15	1	0	17	1	3	1	0	5	0	13	2	0	15	1	3	0	0	4	41
05:00 PM	0	0	0	0	0	0	0	0	0	0	0	1	0	0	1	0	3	0	0	3	4
05:15 PM	0	1	0	0	1	0	1	0	0	1	0	3	0	0	3	0	2	0	0	2	7
05:30 PM	0	1	0	0	1	0	1	0	0	1	0	7	1	0	8	0	4	0	0	4	14
05:45 PM	0	7	0	0	7	0	0	0	0	0	0	5	2	0	7	0	1	0	0	1	15
Total	0	9	0	0	9	0	2	0	0	2	0	16	3	0	19	0	10	0	0	10	40
Grand Total	1	24	1	0	26	1	5	1	0	7	0	29	5	0	34	1	13	0	0	14	81
Apprch %	3.8	92.3	3.8	0		14.3	71.4	14.3	0		0	85.3	14.7	0		7.1	92.9	0	0		
Total %	1.2	29.6	1.2	0	32.1	1.2	6.2	1.2	0	8.6	0	35.8	6.2	0	42	1.2	16	0	0	17.3	

Start Time	MOFFETT BLVD Southbound				CENTRAL EXPY Westbound				CASTRO ST Northbound				CENTRAL EXPY Eastbound				Int. Total
	Right	Thru	Left	App. Total	Right	Thru	Left	App. Total	Right	Thru	Left	App. Total	Right	Thru	Left	App. Total	
Peak Hour Analysis From 04:00 PM to 05:45 PM - Peak 1 of 1																	
Peak Hour for Entire Intersection Begins at 04:00 PM																	
04:00 PM	0	1	0	1	0	0	0	0	0	1	1	2	0	1	0	1	4
04:15 PM	0	5	0	5	0	0	1	1	0	8	0	8	0	0	0	0	14
04:30 PM	0	5	1	6	0	0	0	0	0	2	1	3	1	1	0	2	11
04:45 PM	1	4	0	5	1	3	0	4	0	2	0	2	0	1	0	1	12
Total Volume	1	15	1	17	1	3	1	5	0	13	2	15	1	3	0	4	41
% App. Total	5.9	88.2	5.9		20	60	20		0	86.7	13.3		25	75	0		
PHF	.250	.750	.250	.708	.250	.250	.250	.313	.000	.406	.500	.469	.250	.750	.000	.500	.732

Traffic Data Service

Campbell, CA

(408) 377-2988

tdsbay@cs.com

File Name : 90PM FINAL

Site Code : 00000090

Start Date : 6/5/2013

Page No : 2

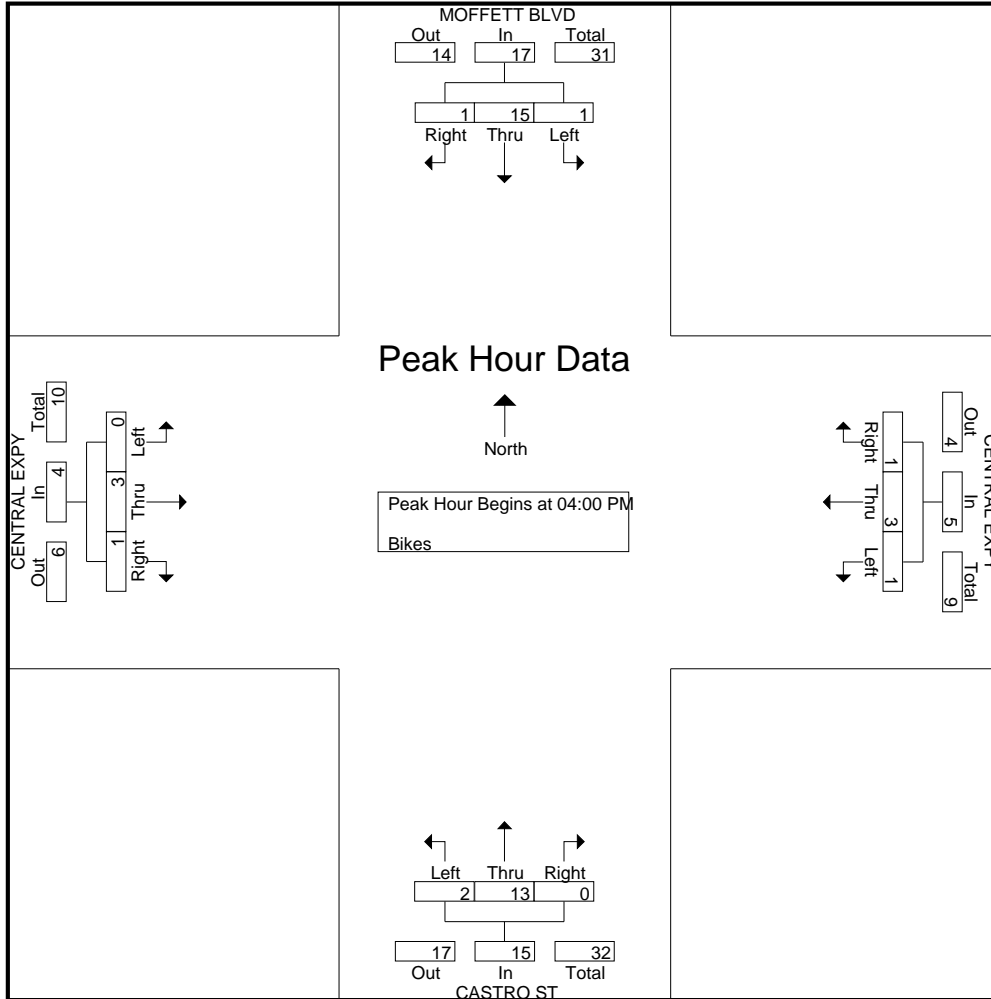

Traffic Data Service

Campbell, CA
 (408) 377-2988
 tdsbay@cs.com

File Name : 5AM FINAL
 Site Code : 00000005
 Start Date : 9/24/2013
 Page No : 1

Groups Printed- Vehicles

Start Time	OUTER LOOP Southbound					INNER LOOP Southwestbound					W EVELYN AVE Westbound					HOPE ST Northbound					W EVELYN AVE Eastbound					Int. Total			
	Right	Thru	Left	Peds	App. Total	Bear Right	Bear Left	Hard Left	Peds	App. Total	Hard Right	Right	Thru	Left	Peds	App. Total	Right	Bear Right	Thru	Left	Peds	App. Total	Right	Thru	Bear Left		Left	Peds	App. Total
07:00 AM	3	2	0	8	13	2	0	2	0	4	2	2	30	11	6	51	6	0	3	1	5	15	1	0	0	1	1	3	86
07:15 AM	0	4	0	10	14	0	0	0	0	0	0	0	37	9	8	54	7	0	3	2	3	15	2	2	0	0	0	4	87
07:30 AM	0	0	0	6	6	0	0	0	0	0	0	1	44	8	9	62	12	2	3	6	5	28	2	2	0	1	0	5	101
07:45 AM	5	3	0	15	23	3	1	1	0	5	4	1	47	7	40	99	31	0	4	5	15	55	0	1	0	0	0	1	183
Total	8	9	0	39	56	5	1	3	0	9	6	4	158																
08:00 AM	2	1	0	18	21	2	1	5	0	8	3	0	56	14	9	82	13	1	3	2	7	26	0	7	0	0	2	9	146
08:15 AM	2	3	0	19	24	1	1	0	0	2	2	2	69	11	20	104	9	0	1	2	4	16	0	7	0	2	3	12	158
08:30 AM	2	0	0	13	15	0	0	0	0	0	5	0	73	11	20	109	15	0	4	8	9	36	2	1	0	1	2	6	166
08:45 AM	2	4	0	26	32	1	1	4	0	6	4	0	64	12	17	97	17	0	1	7	7	32	2	4	0	1	2	9	176
Total	8	8	0	76	92	4	3	9	0	16	14	2	262																
Grand Total	16	17	0	115	148	9	4	12	0	25	20	6	420	83	129	658	110	3	22	33	55	223	9	24	0	6	10	49	1103
Apprch %	10.8	11.5	0	77.7	36	16	48	0	2.3	3	0.9	63.8	12.6	19.6	49.3	1.3	9.9	14.8	24.7	18.4	49	0	12.2	20.4					
Total %	1.5	1.5	0	10.4	13.4	0.8	0.4	1.1	0	2.3	1.8	0.5	38.1	7.5	11.7	59.7	10	0.3	2	3	5	20.2	0.8	2.2	0	0.5	0.9	4.4	

Start Time	OUTER LOOP Southbound					INNER LOOP Southwestbound					W EVELYN AVE Westbound					HOPE ST Northbound					W EVELYN AVE Eastbound					Int. Total
	Right	Thru	Left	App. Total	Bear Right	Bear Left	Hard Left	App. Total	Hard Right	Right	Thru	Left	App. Total	Right	Bear Right	Thru	Left	App. Total	Right	Thru	Bear Left	Left	App. Total			
Peak Hour Analysis From 07:00 AM to 08:45 AM - Peak 1 of 1																										
Peak Hour for Entire Intersection Begins at 08:00 AM																										
08:00 AM	2	1	0	3	2	1	5	8	3	0	56	14	73	13	1	3	2	19	0	7	0	0	7	110		
08:15 AM	2	3	0	5	1	1	0	2	2	2	69	11	84	9	0	1	2	12	0	7	0	2	9	112		
08:30 AM	2	0	0	2	0	0	0	0	5	0	73	11	89	15	0	4	8	27	2	1	0	1	4	122		
08:45 AM	2	4	0	6	1	1	4	6	4	0	64	12	80	17	0	1	7	25	2	4	0	1	7	124		
Total Volume	8	8	0	16	4	3	9	16	14	2	262	48	326	54	1	9	19	83	4	19	0	4	27	468		
% App. Total	50	50	0	25	18.8	56.2	4.3	0.6	80.4	14.7	65.1	1.2	10.8	22.9	14.8	70.4	0	14.8								
PHF	1.0	.500	.000	.667	.500	.750	.450	.500	.700	.250	.897	.857	.916	.794	.250	.563	.594	.769	.500	.679	.000	.500	.750	.944		

Traffic Data Service

Campbell, CA
 (408) 377-2988
 tdsbay@cs.com

File Name : 5AM FINAL
 Site Code : 00000005
 Start Date : 9/24/2013
 Page No : 2

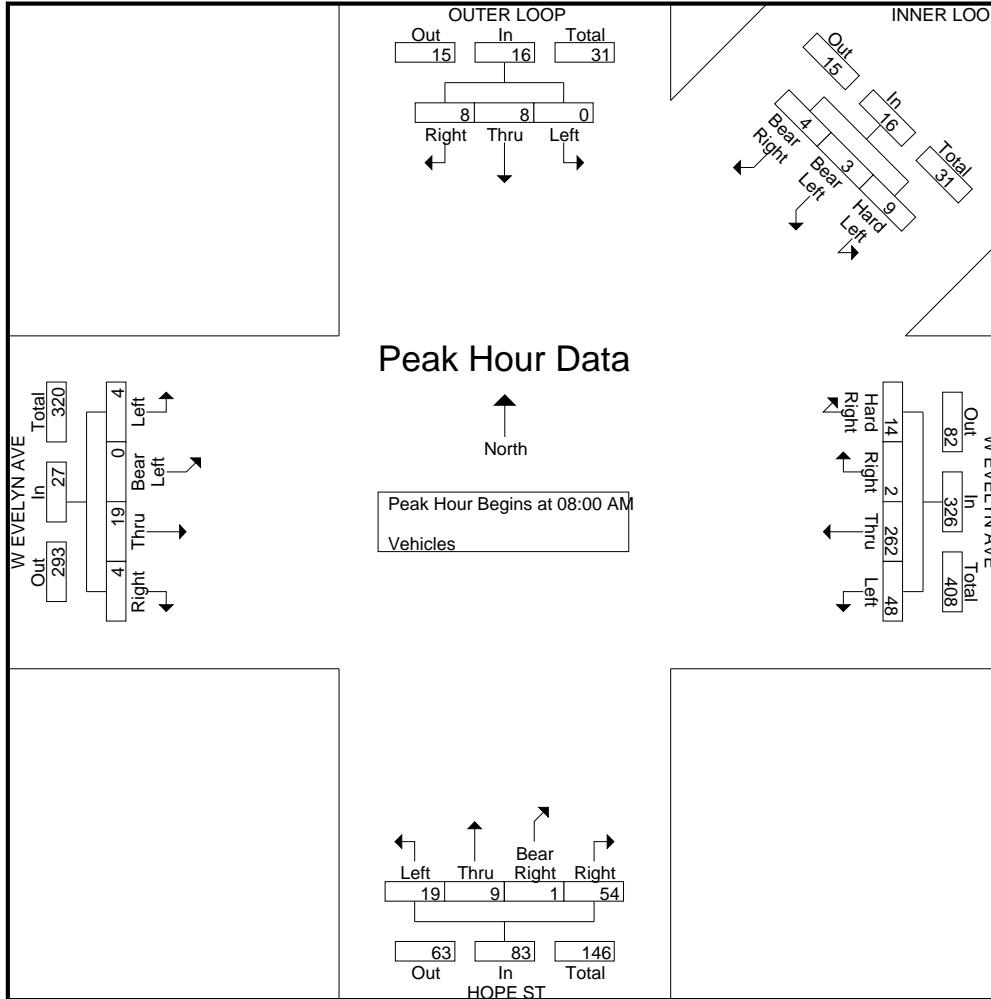

Traffic Data Service

Campbell, CA
 (408) 377-2988
 tdsbay@cs.com

File Name : 5AM FINAL
 Site Code : 00000005
 Start Date : 9/24/2013
 Page No : 1

Groups Printed- Bikes

Start Time	OUTER LOOP Southbound					INNER LOOP Southwestbound					W EVELYN AVE Westbound					HOPE ST Northbound					W EVELYN AVE Eastbound					Int. Total									
	Right	Thru	Left	Peds	App. Total	Bear Right	Bear Left	Hard Left	Peds	App. Total	Hard Right	Right	Thru	Left	Peds	App. Total	Right	Bear Right	Thru	Left	Peds	App. Total	Right	Thru	Bear Left		Left	Peds	App. Total						
07:00 AM	0	0	0	0	0	0	0	0	0	0	0	0	4	0	0	4	2	1	0	0	0	3	1	1	0	0	0	2	9						
07:15 AM	0	0	0	0	0	0	0	0	0	0	0	0	0	0	0	0	0	0	0	1	0	1	0	0	0	1	0	1	2						
07:30 AM	0	1	0	0	1	0	0	0	0	0	0	0	3	0	0	3	0	0	0	0	0	0	0	0	0	0	0	0	4						
07:45 AM	0	0	0	0	0	0	0	0	0	0	0	0	8	2	0	10	1	0	0	0	0	1	0	0	0	0	0	0	11						
Total	0	1	0	0	1	0	0	0	0	0	0	0	15	2	0	17	3	1	0	1	0	5	1	1	0	1	0	3	26						
08:00 AM	0	1	0	0	1	0	0	0	0	0	1	0	3	1	0	5	0	0	0	0	0	0	1	0	0	0	0	1	7						
08:15 AM	0	1	0	0	1	0	0	0	0	0	0	0	2	1	0	3	0	0	0	0	0	0	0	0	0	0	0	0	4						
08:30 AM	0	0	0	0	0	0	0	0	0	0	0	0	2	0	0	2	1	0	0	0	0	1	1	0	0	1	0	2	5						
08:45 AM	0	0	0	0	0	0	0	0	0	0	0	0	5	0	0	5	0	1	1	1	0	3	1	0	0	1	0	2	10						
Total	0	2	0	0	2	0	0	0	0	0	1	0	12	2	0	15	1	1	1	1	0	4	3	0	0	2	0	5	26						
Grand Total																																			
Apprch %	100					3.1					84.4 12.5					44.4 22.2 11.1 22.2					12.5 37.5														
	5.8					1.9					51.9 7.7					61.5					7.7 3.8 1.9 3.8					17.3					7.7 1.9 5.8 15.4				

Start Time	OUTER LOOP Southbound				INNER LOOP Southwestbound				W EVELYN AVE Westbound				HOPE ST Northbound				W EVELYN AVE Eastbound				Int. Total			
	Right	Thru	Left	App. Total	Bear Right	Bear Left	Hard Left	App. Total	Hard Right	Right	Thru	Left	App. Total	Right	Bear Right	Thru	Left	App. Total	Right	Thru		Bear Left	Left	App. Total
07:45 AM	0	0	0	0	0	0	0	0	0	0	8	2	10	1	0	0	0	1	0	0	0	0	0	11
08:00 AM	0	1	0	1	0	0	0	0	1	0	3	1	5	0	0	0	0	0	1	0	0	0	0	7
08:15 AM	0	1	0	1	0	0	0	0	0	0	2	1	3	0	0	0	0	0	0	0	0	0	0	4
08:30 AM	0	0	0	0	0	0	0	0	0	0	2	0	2	1	0	0	0	1	1	0	0	1	0	5
Total Volume	0	2	0	2	0	0	0	0	1	0	15	4	20	2	0	0	0	2	2	0	0	1	0	27
% App. Total	0	100	0		0	0	0		5	0	75	20		100	0	0	0		66.7	0	0	33.3		
PHF	.000	.500	.000	.500	.000	.000	.000	.000	.250	.000	.469	.500	.500	.500	.000	.000	.000	.500	.500	.000	.000	.250	.375	.614

Peak Hour Analysis From 07:00 AM to 08:45 AM - Peak 1 of 1

Peak Hour for Entire Intersection Begins at 07:45 AM

Traffic Data Service

Campbell, CA
 (408) 377-2988
 tdsbay@cs.com

File Name : 5AM FINAL
 Site Code : 00000005
 Start Date : 9/24/2013
 Page No : 2

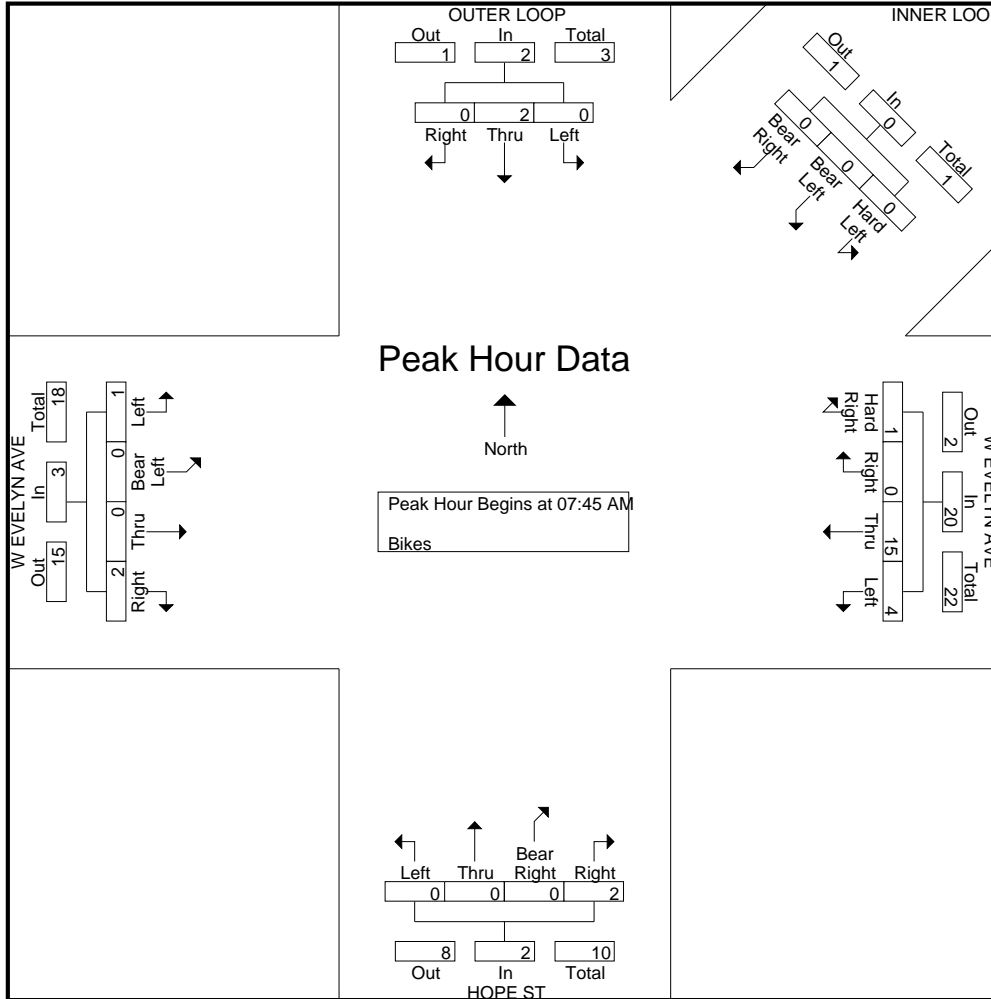

Traffic Data Service

Campbell, CA
(408) 377-2988
tdsbay@cs.com

File Name : 5PM FINAL
Site Code : 00000005
Start Date : 9/24/2013
Page No : 1

Groups Printed- Vehicles

Start Time	OUTER LOOP Southbound					INNER LOOP Southwestbound					W EVELYN AVE Westbound					HOPE ST Northbound					W EVELYN AVE Eastbound					Int. Total			
	Right	Thru	Left	Peds	App. Total	Bear Right	Bear Left	Hard Left	Peds	App. Total	Hard Right	Right	Thru	Left	Peds	App. Total	Right	Bear Right	Thru	Left	Peds	App. Total	Right	Thru	Bear Left		Left	Peds	App. Total
04:00 PM	1	0	0	2	3	0	0	0	0	0	0	0	24	5	2	31	24	0	0	3	2	29	2	2	0	1	1	6	69
04:15 PM	0	1	0	8	9	4	0	0	0	4	1	0	32	15	14	62	26	2	0	6	5	39	3	6	0	2	3	14	128
04:30 PM	0	2	0	9	11	3	0	0	0	3	2	1	33	14	16	66	29	2	0	7	0	38	1	3	0	0	1	5	123
04:45 PM	0	1	0	18	19	5	0	0	0	5	1	0	49	11	29	90	31	2	0	6	11	50	6	9	1	0	1	17	181
Total	1	4	0	37	42	12	0	0	0	12	4	1	138				110												
05:00 PM	0	1	1	10	12	1	0	0	0	1	0	0	35	18	20	73	36	1	1	15	6	59	3	5	0	1	1	10	155
05:15 PM	0	1	0	16	17	4	0	0	0	4	1	0	33	23	18	75	25	4	0	11	11	51	2	12	0	1	1	16	163
05:30 PM	2	0	0	21	23	1	1	0	0	2	0	0	47	16	35	98	39	0	1	14	15	69	5	4	0	2	1	12	204
05:45 PM	0	2	0	13	15	5	0	0	0	5	1	1	33	15	29	79	34	4	1	10	4	53	3	8	0	0	1	12	164
Total	2	4	1	60	67	11	1	0	0	12	2	1	148				134												
Grand Total	3	8	1	97	109	23	1	0	0	24	6	2	286	117	163	574	244	15	3	72	54	388	25	49	1	7	10	92	1187
Apprch %	2.8	7.3	0.9	89		95.8	4.2	0	0		1	0.3	49.8	20.4	28.4		62.9	3.9	0.8	18.6	13.9		27.2	53.3	1.1	7.6	10.9		
Total %	0.3	0.7	0.1	8.2	9.2	1.9	0.1	0	0	2	0.5	0.2	24.1	9.9	13.7	48.4	20.6	1.3	0.3	6.1	4.5	32.7	2.1	4.1	0.1	0.6	0.8	7.8	

Start Time	OUTER LOOP Southbound				INNER LOOP Southwestbound					W EVELYN AVE Westbound					HOPE ST Northbound					W EVELYN AVE Eastbound					Int. Total	
	Right	Thru	Left	App. Total	Bear Right	Bear Left	Hard Left	Peds	App. Total	Hard Right	Right	Thru	Left	App. Total	Right	Bear Right	Thru	Left	App. Total	Right	Thru	Bear Left	Left	App. Total		
Peak Hour Analysis From 04:00 PM to 05:45 PM - Peak 1 of 1																										
Peak Hour for Entire Intersection Begins at 04:45 PM																										
04:45 PM	0	1	0	1	5	0	0	0	5	1	0	49	11	61	31	2	0	6	39	6	9	1	0	16	122	
05:00 PM	0	1	1	2	1	0	0	0	1	0	0	35	18	53	36	1	1	15	53	3	5	0	1	9	118	
05:15 PM	0	1	0	1	4	0	0	0	4	1	0	33	23	57	25	4	0	11	40	2	12	0	1	15	117	
05:30 PM	2	0	0	2	1	1	0	0	2	0	0	47	16	63	39	0	1	14	54	5	4	0	2	11	132	
Total Volume	2	3	1	6	11	1	0	0	12	2	0	164	68	234	131	7	2	46	186	16	30	1	4	51	489	
% App. Total	33.3	50	16.7		91.7	8.3	0	0		0.9	0	70.1	29.1		70.4	3.8	1.1	24.7		31.4	58.8	2	7.8			
PHF	.250	.750	.250	.750	.550	.250	.000	.000	.600	.500	.000	.837	.739	.929	.840	.438	.500	.767	.861	.667	.625	.250	.500	.797	.926	

Traffic Data Service

Campbell, CA
 (408) 377-2988
 tdsbay@cs.com

File Name : 5PM FINAL
 Site Code : 00000005
 Start Date : 9/24/2013
 Page No : 2

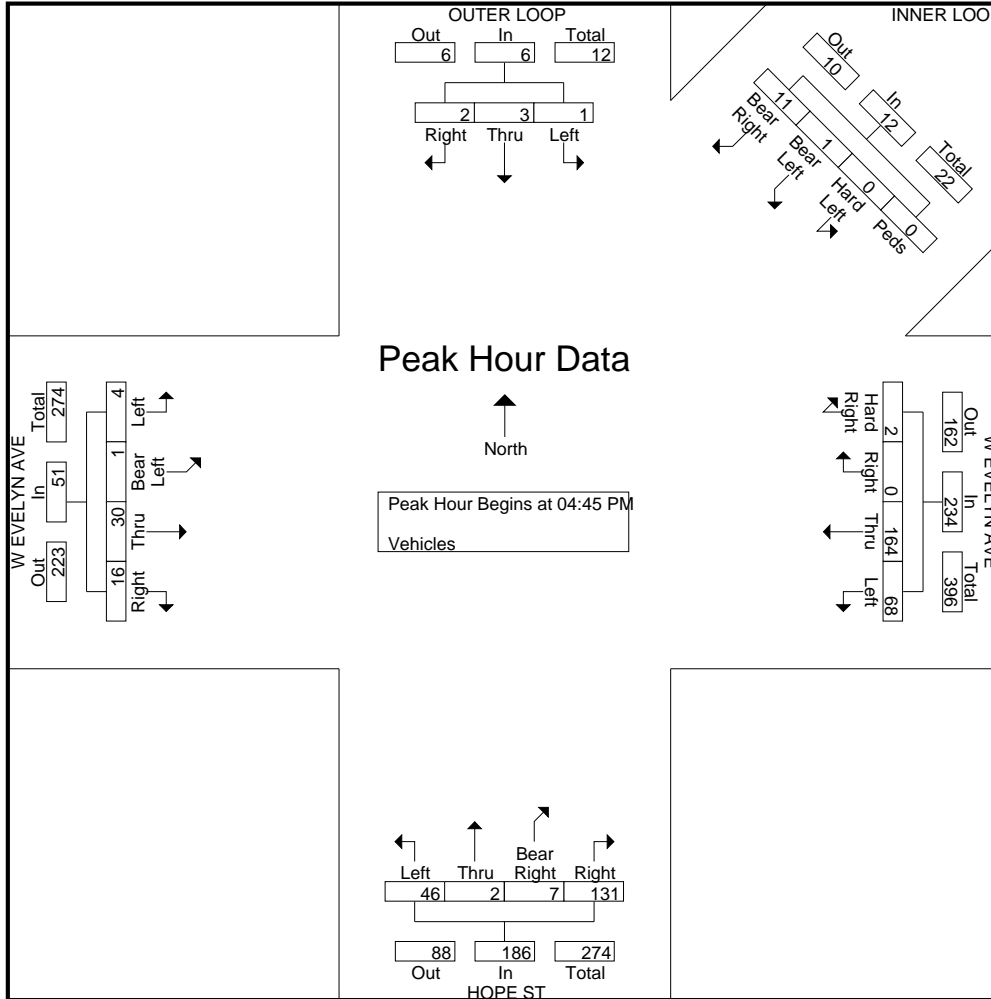

Traffic Data Service

Campbell, CA
 (408) 377-2988
 tdsbay@cs.com

File Name : 5PM FINAL
 Site Code : 00000005
 Start Date : 9/24/2013
 Page No : 1

Groups Printed- Bikes

Start Time	OUTER LOOP Southbound					INNER LOOP Southwestbound					W EVELYN AVE Westbound					HOPE ST Northbound					W EVELYN AVE Eastbound					Int. Total																																							
	Right	Thru	Left	Peds	App. Total	Bear Right	Bear Left	Hard Left	Peds	App. Total	Hard Right	Right	Thru	Left	Peds	App. Total	Right	Bear Right	Thru	Left	Peds	App. Total	Right	Thru	Bear Left		Left	Peds	App. Total																																				
04:00 PM	0	0	0	0	0	0	0	0	0	0	0	0	1	0	0	1	0	0	0	0	0	0	0	0	0	0	0	1																																					
04:15 PM	0	0	0	0	0	0	0	0	0	0	0	0	0	0	0	0	0	0	1	0	0	1	0	0	0	0	1	2																																					
04:30 PM	0	0	0	0	0	0	0	0	0	0	0	0	0	0	0	0	3	0	0	0	0	0	3	0	2	0	1	3																																					
04:45 PM	0	0	0	0	0	0	0	0	0	0	0	0	2	0	0	2	2	0	0	0	0	0	2	1	1	0	2	4																																					
Total	0	0	0	0	0	0	0	0	0	0	0	0	3	0	0	3	5	0	1	0	0	0	6	1	4	0	3	8	17																																				
05:00 PM	0	1	0	0	1	0	0	0	0	0	0	0	0	0	0	1	0	0	0	0	0	1	1	1	0	0	0	2	4																																				
05:15 PM	0	0	0	0	0	0	0	0	0	0	0	0	0	0	0	2	0	0	0	0	0	2	0	1	0	0	0	1	3																																				
05:30 PM	0	0	0	0	0	0	0	0	0	0	1	0	3	0	0	4	1	0	0	0	0	1	0	0	0	0	0	0	5																																				
05:45 PM	0	0	0	0	0	1	0	0	0	1	0	0	1	2	0	3	4	0	0	0	0	0	4	0	1	0	1	0	2	10																																			
Total	0	1	0	0	1	1	0	0	0	1	1	0	4	2	0	7	8	0	0	0	0	0	8	1	3	0	1	0	5	22																																			
Grand Total																																																																	
Apprch %	100					100					2.6					92.9					7.1					15.4					53.8					30.8					33.3																								
	2.6					2.6					2.6					17.9					5.1					25.6					33.3					2.6					35.9					5.1					17.9					10.3					33.3				

Start Time	OUTER LOOP Southbound					INNER LOOP Southwestbound					W EVELYN AVE Westbound					HOPE ST Northbound					W EVELYN AVE Eastbound					Int. Total									
	Right	Thru	Left	App. Total		Bear Right	Bear Left	Hard Left	Peds	App. Total	Hard Right	Right	Thru	Left	App. Total	Right	Bear Right	Thru	Left	App. Total	Right	Thru	Bear Left	Left	App. Total										
05:00 PM	0	1	0	1		0	0	0	0	0	0	0	0	0	0	1	0	0	0	0	1	1	1	0	0	2	4								
05:15 PM	0	0	0	0		0	0	0	0	0	0	0	0	0	0	2	0	0	0	0	2	0	1	0	0	0	1	3							
05:30 PM	0	0	0	0		0	0	0	0	0	1	0	3	0	4	1	0	0	0	0	1	0	0	0	0	0	0	5							
05:45 PM	0	0	0	0		1	0	0	0	1	0	0	1	2	3	4	0	0	0	0	4	0	1	0	1	2	10								
Total Volume	0	1	0	1		1	0	0	0	1	1	0	4	2	7	8	0	0	0	0	8	1	3	0	1	5	22								
% App. Total	100					100					14.3					57.1					28.6					100									
PHF	.000	.250	.000	.250		.250	.000	.000	.000	.250	.250	.000	.333	.250	.438	.500	.000	.000	.000	.500	.250	.750	.000	.250	.625	.550									

Peak Hour Analysis From 04:00 PM to 05:45 PM - Peak 1 of 1

Peak Hour for Entire Intersection Begins at 05:00 PM

Traffic Data Service

Campbell, CA
 (408) 377-2988
 tdsbay@cs.com

File Name : 5PM FINAL
 Site Code : 00000005
 Start Date : 9/24/2013
 Page No : 2

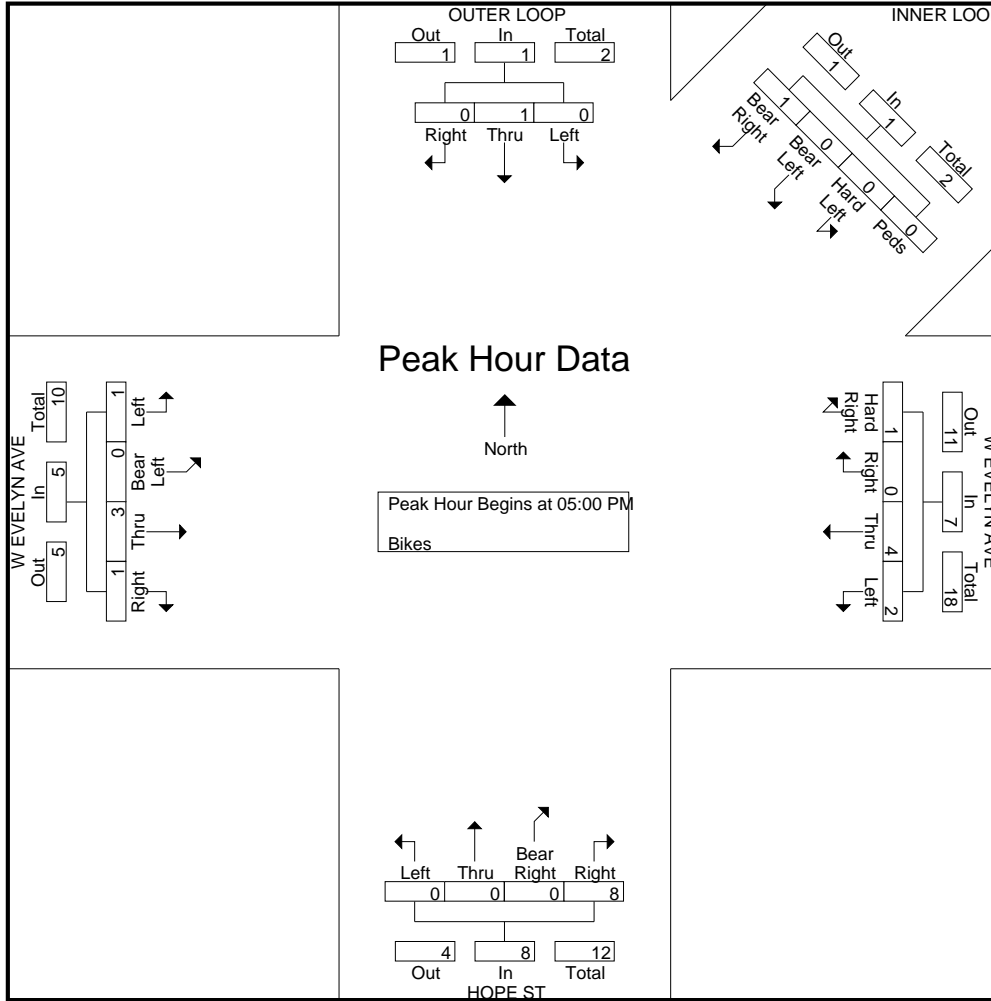

All Traffic Data

(916) 771-8700

City of Mountain View

File Name : 12-7153-025 California-Rengstorff

Site Code : 00000000

Start Date : 4/17/2012

Page No : 1

Groups Printed- Unshifted

Start Time	California Street Southbound				Rengstorff Avenue Westbound				California Street Northbound				Rengstorff Avenue Eastbound				Int. Total
	Left	Thru	Right	App. Total	Left	Thru	Right	App. Total	Left	Thru	Right	App. Total	Left	Thru	Right	App. Total	
07:00	17	30	5	52	6	33	16	55	4	44	16	64	5	26	7	38	209
07:15	22	27	8	57	23	51	21	95	10	53	19	82	9	40	6	55	289
07:30	25	48	15	88	22	68	19	109	14	56	25	95	7	53	9	69	361
07:45	12	49	16	77	17	94	26	137	18	81	18	117	8	64	10	82	413
Total	76	154	44	274	68	246	82	396	46	234	78	358	29	183	32	244	1272
08:00	32	60	18	110	23	75	31	129	14	71	28	113	7	89	9	105	457
08:15	31	48	19	98	34	71	23	128	14	82	33	129	11	100	6	117	472
08:30	24	42	6	72	23	83	31	137	7	79	41	127	17	86	3	106	442
08:45	29	52	14	95	20	52	26	98	16	73	27	116	14	92	7	113	422
Total	116	202	57	375	100	281	111	492	51	305	129	485	49	367	25	441	1793
16:00	39	98	16	153	23	86	44	153	11	68	18	97	9	75	15	99	502
16:15	36	102	13	151	37	80	47	164	9	74	20	103	8	49	16	73	491
16:30	46	101	7	154	26	89	47	162	14	79	20	113	9	76	12	97	526
16:45	48	99	9	156	24	81	42	147	15	58	20	93	4	68	15	87	483
Total	169	400	45	614	110	336	180	626	49	279	78	406	30	268	58	356	2002
17:00	27	101	9	137	44	86	46	176	7	87	21	115	14	59	12	85	513
17:15	42	118	13	173	45	106	52	203	21	84	23	128	8	69	14	91	595
17:30	43	128	15	186	40	124	37	201	8	87	23	118	6	82	11	99	604
17:45	32	138	17	187	49	77	45	171	15	89	18	122	11	83	16	110	590
Total	144	485	54	683	178	393	180	751	51	347	85	483	39	293	53	385	2302
Grand Total	505	1241	200	1946	456	1256	553	2265	197	1165	370	1732	147	1111	168	1426	7369
Apprch %	26	63.8	10.3		20.1	55.5	24.4		11.4	67.3	21.4		10.3	77.9	11.8		
Total %	6.9	16.8	2.7	26.4	6.2	17	7.5	30.7	2.7	15.8	5	23.5	2	15.1	2.3	19.4	

Start Time	California Street Southbound				Rengstorff Avenue Westbound				California Street Northbound				Rengstorff Avenue Eastbound				Int. Total
	Left	Thru	Right	App. Total	Left	Thru	Right	App. Total	Left	Thru	Right	App. Total	Left	Thru	Right	App. Total	
Peak Hour Analysis From 07:00 to 08:45 - Peak 1 of 1																	
Peak Hour for Entire Intersection Begins at 08:00																	
08:00	32	60	18	110	23	75	31	129	14	71	28	113	7	89	9	105	457
08:15	31	48	19	98	34	71	23	128	14	82	33	129	11	100	6	117	472
08:30	24	42	6	72	23	83	31	137	7	79	41	127	17	86	3	106	442
08:45	29	52	14	95	20	52	26	98	16	73	27	116	14	92	7	113	422
Total Volume	116	202	57	375	100	281	111	492	51	305	129	485	49	367	25	441	1793
% App. Total	30.9	53.9	15.2		20.3	57.1	22.6		10.5	62.9	26.6		11.1	83.2	5.7		

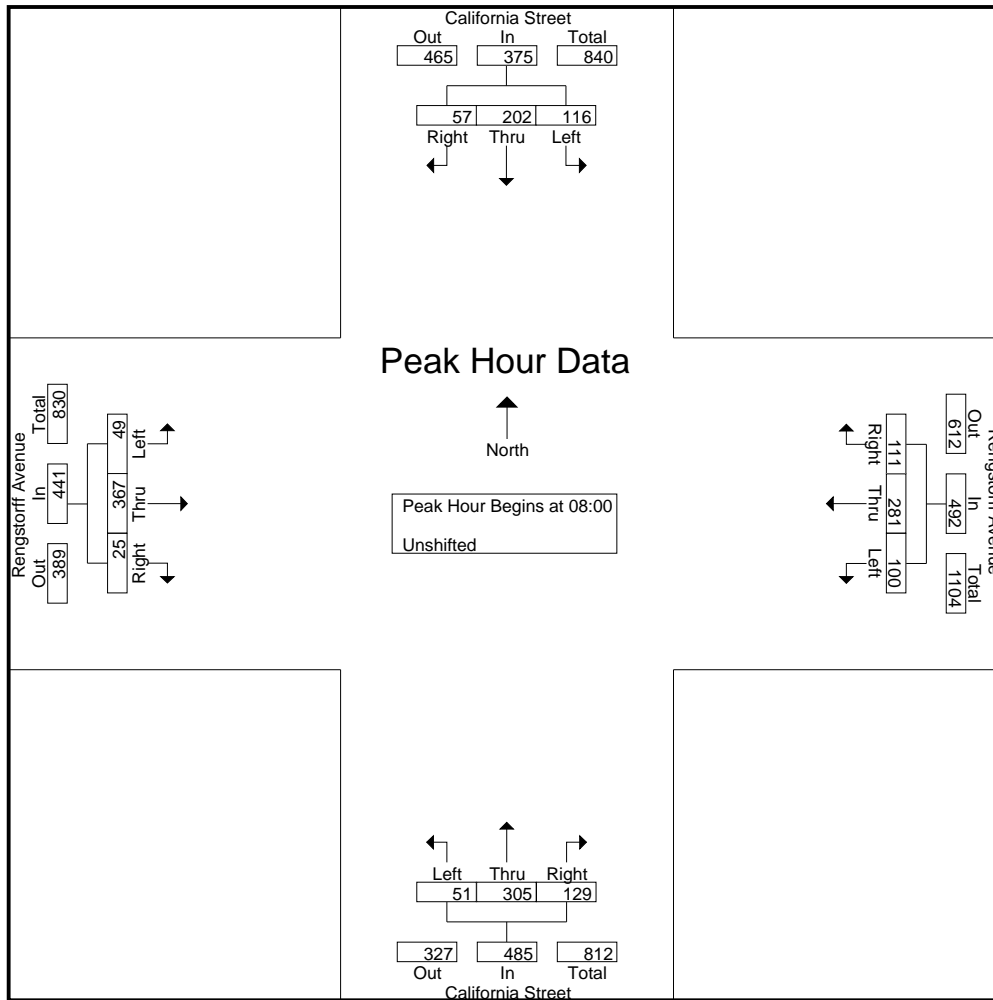

Peak Hour Analysis From 16:00 to 17:45 - Peak 1 of 1
 Peak Hour for Entire Intersection Begins at 17:00

17:00	27	101	9	137	44	86	46	176	7	87	21	115	14	59	12	85	513
17:15	42	118	13	173	45	106	52	203	21	84	23	128	8	69	14	91	595
17:30	43	128	15	186	40	124	37	201	8	87	23	118	6	82	11	99	604
17:45	32	138	17	187	49	77	45	171	15	89	18	122	11	83	16	110	590
Total Volume	144	485	54	683	178	393	180	751	51	347	85	483	39	293	53	385	2302
% App. Total	21.1	71	7.9		23.7	52.3	24		10.6	71.8	17.6		10.1	76.1	13.8		
PHF	.837	.879	.794	.913	.908	.792	.865	.925	.607	.975	.924	.943	.696	.883	.828	.875	.953

All Traffic Data

(916) 771-8700

City of Mountain View

File Name : 12-7153-025 California-Rengstorff

Site Code : 00000000

Start Date : 4/17/2012

Page No : 3

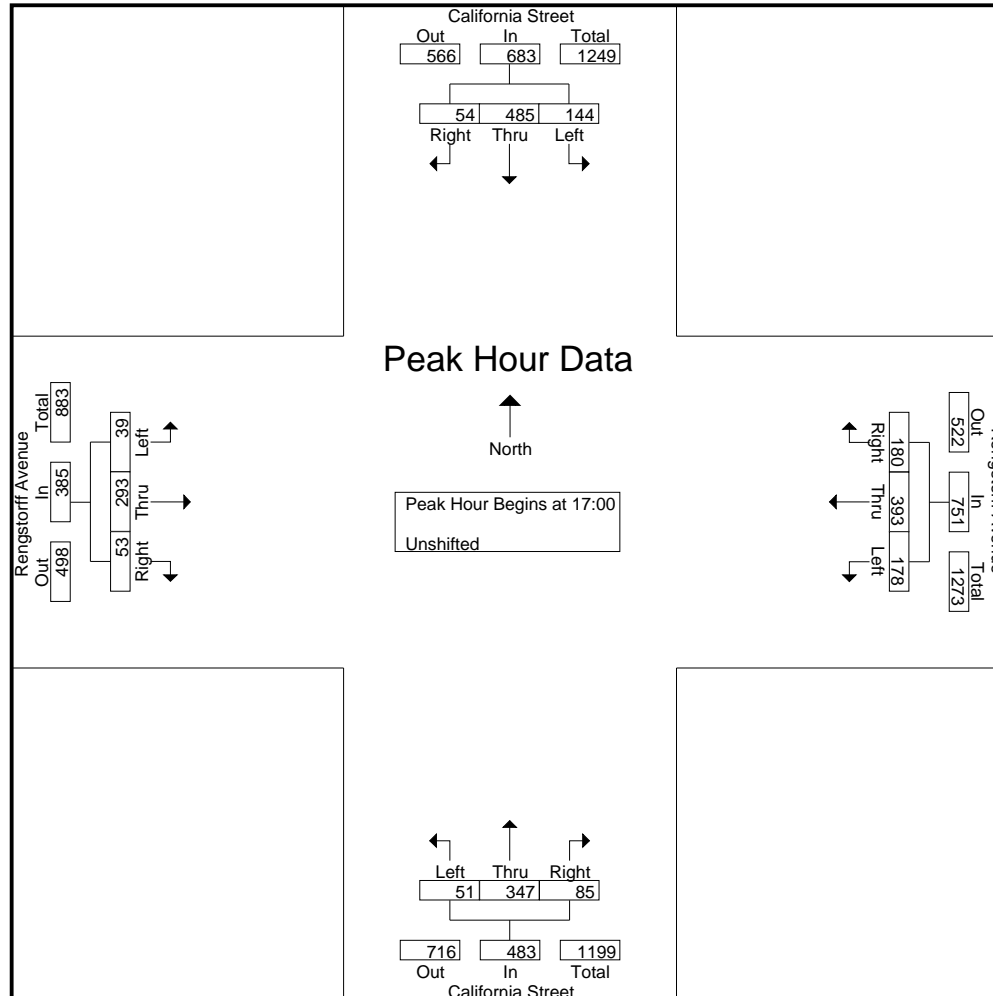

Turning Movement Count

60 Minute Counts

DATE	TIME	INTID	NBL	NBT	NBR	SBL	SBT	SBR
#####	1700	5			226	33		338
#####	1700	8			83			55
#####	1700	10						
#####	1700	11						
#####	1700	14					8	8
#####	1700	16					12	4
#####	1700	92		19		64		
#####	1700	229	16	171	33	134	197	7

EBL	EBT	EBR	WBL	WBT	WBR	
					287	
		309			234	
		309			234	
		99			325	
	1	91			310	15
	10	23			283	6
		28	7	48	270	
	49	142	8	36	159	39

Turning Movement Count

60 Minute Counts

DATE	TIME	INTID	NBL	NBT	NBR	SBL	SBT	SBR
#####	1700	5			313	56		504
#####	1700	8			186			86
#####	1700	10						
#####	1700	11						
#####	1700	14					4	2
#####	1700	16					1	11
#####	1700	92	46			140		
#####	1700	229	34	248	37	202	239	63

EBL	EBT	EBR	WBL	WBT	WBR
					224
		430		267	
		430		267	
		174		242	
	4	170		234	8
	6	50		213	
		34	17	69	167
	62	191	32	22	186
					59

Traffic Data Service

Campbell, CA
 (408) 377-2988
 tdsbay@cs.com

File Name : 93AM FINAL
 Site Code : 00000093
 Start Date : 6/4/2013
 Page No : 1

Groups Printed- Vehicles

Start Time	N. MARY AVE Southbound					W. EVELYN AVE Westbound					S. MARY AVE Northbound					W. EVELYN AVE Eastbound					Int. Total
	Right	Thru	Left	Peds	App. Total	Right	Thru	Left	Peds	App. Total	Right	Thru	Left	Peds	App. Total	Right	Thru	Left	Peds	App. Total	
07:00 AM	29	57	4	0	90	18	30	8	5	61	7	71	3	2	83	8	27	35	1	71	305
07:15 AM	41	100	5	0	146	17	41	9	2	69	3	95	11	1	110	4	16	24	4	48	373
07:30 AM	46	105	6	0	157	26	56	21	2	105	4	155	8	1	168	6	28	27	2	63	493
07:45 AM	59	130	13	0	202	43	60	15	6	124	11	229	16	3	259	7	29	36	3	75	660
Total	175	392	28	0	595	104	187	53	15	359	25	550	38	7	620	25	100	122	10	257	1831
08:00 AM	41	130	22	0	193	51	59	22	3	135	7	242	22	10	281	9	39	40	7	95	704
08:15 AM	49	79	14	2	144	59	78	22	4	163	5	279	12	6	302	7	33	50	4	94	703
08:30 AM	34	65	11	0	110	59	70	12	2	143	8	286	22	1	317	12	33	67	2	114	684
08:45 AM	37	63	12	0	112	59	57	12	2	130	8	271	19	8	306	3	25	33	7	68	616
Total	161	337	59	2	559	228	264	68	11	571	28	1078	75	25	1206	31	130	190	20	371	2707
Grand Total	336	729	87	2	1154	332	451	121	26	930	53	1628	113	32	1826	56	230	312	30	628	4538
Apprch %	29.1	63.2	7.5	0.2		35.7	48.5	13	2.8		2.9	89.2	6.2	1.8		8.9	36.6	49.7	4.8		
Total %	7.4	16.1	1.9	0	25.4	7.3	9.9	2.7	0.6	20.5	1.2	35.9	2.5	0.7	40.2	1.2	5.1	6.9	0.7	13.8	

Start Time	N. MARY AVE Southbound				W. EVELYN AVE Westbound				S. MARY AVE Northbound				W. EVELYN AVE Eastbound				Int. Total
	Right	Thru	Left	App. Total	Right	Thru	Left	App. Total	Right	Thru	Left	App. Total	Right	Thru	Left	App. Total	
Peak Hour Analysis From 07:00 AM to 08:45 AM - Peak 1 of 1																	
Peak Hour for Entire Intersection Begins at 07:45 AM																	
07:45 AM	59	130	13	202	43	60	15	118	11	229	16	256	7	29	36	72	648
08:00 AM	41	130	22	193	51	59	22	132	7	242	22	271	9	39	40	88	684
08:15 AM	49	79	14	142	59	78	22	159	5	279	12	296	7	33	50	90	687
08:30 AM	34	65	11	110	59	70	12	141	8	286	22	316	12	33	67	112	679
Total Volume	183	404	60	647	212	267	71	550	31	1036	72	1139	35	134	193	362	2698
% App. Total	28.3	62.4	9.3		38.5	48.5	12.9		2.7	91	6.3		9.7	37	53.3		
PHF	.775	.777	.682	.801	.898	.856	.807	.865	.705	.906	.818	.901	.729	.859	.720	.808	.982

Traffic Data Service

Campbell, CA
 (408) 377-2988
 tdsbay@cs.com

File Name : 93AM FINAL
 Site Code : 00000093
 Start Date : 6/4/2013
 Page No : 2

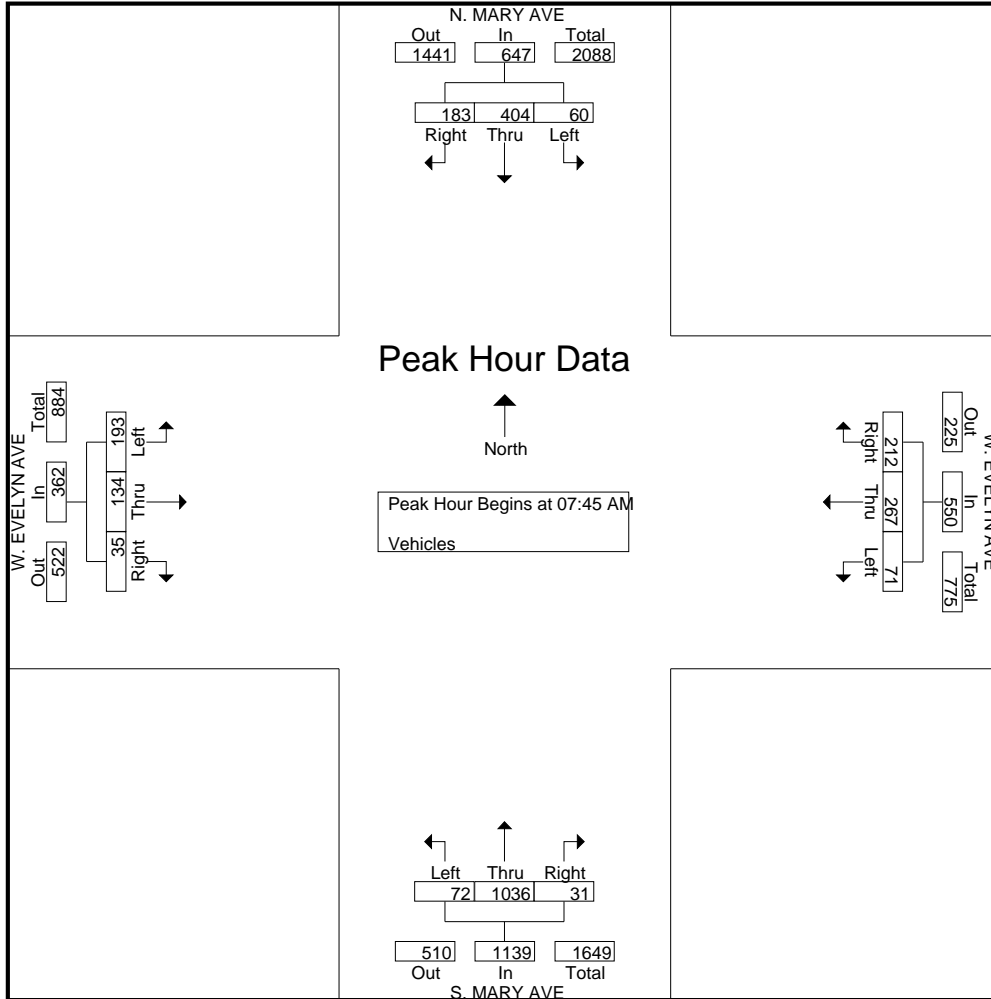

Traffic Data Service

Campbell, CA
 (408) 377-2988
 tdsbay@cs.com

File Name : 93AM FINAL
 Site Code : 00000093
 Start Date : 6/4/2013
 Page No : 1

Groups Printed- Bikes

Start Time	N. MARY AVE Southbound					W. EVELYN AVE Westbound					S. MARY AVE Northbound					W. EVELYN AVE Eastbound					Int. Total
	Right	Thru	Left	Peds	App. Total	Right	Thru	Left	Peds	App. Total	Right	Thru	Left	Peds	App. Total	Right	Thru	Left	Peds	App. Total	
07:00 AM	0	0	0	0	0	1	11	0	0	12	0	1	0	0	1	0	1	1	0	2	15
07:15 AM	2	0	0	0	2	1	4	0	0	5	0	2	0	0	2	0	3	1	0	4	13
07:30 AM	0	0	1	0	1	3	7	0	0	10	0	4	0	0	4	0	7	0	0	7	22
07:45 AM	1	1	0	0	2	0	10	0	0	10	0	3	0	0	3	0	5	2	0	7	22
Total	3	1	1	0	5	5	32	0	0	37	0	10	0	0	10	0	16	4	0	20	72
08:00 AM	1	0	0	0	1	5	5	0	0	10	0	2	0	0	2	0	3	4	0	7	20
08:15 AM	4	0	0	0	4	1	7	0	0	8	0	6	0	0	6	1	7	0	0	8	26
08:30 AM	1	1	0	0	2	1	14	0	0	15	0	4	0	0	4	0	2	0	0	2	23
08:45 AM	2	0	1	0	3	2	4	0	0	6	0	4	0	0	4	0	3	0	0	3	16
Total	8	1	1	0	10	9	30	0	0	39	0	16	0	0	16	1	15	4	0	20	85
Grand Total	11	2	2	0	15	14	62	0	0	76	0	26	0	0	26	1	31	8	0	40	157
Apprch %	73.3	13.3	13.3	0		18.4	81.6	0	0		0	100	0	0		2.5	77.5	20	0		
Total %	7	1.3	1.3	0	9.6	8.9	39.5	0	0	48.4	0	16.6	0	0	16.6	0.6	19.7	5.1	0	25.5	

Start Time	N. MARY AVE Southbound				W. EVELYN AVE Westbound				S. MARY AVE Northbound				W. EVELYN AVE Eastbound				Int. Total
	Right	Thru	Left	App. Total	Right	Thru	Left	App. Total	Right	Thru	Left	App. Total	Right	Thru	Left	App. Total	
Peak Hour Analysis From 07:00 AM to 08:45 AM - Peak 1 of 1																	
Peak Hour for Entire Intersection Begins at 07:45 AM																	
07:45 AM	1	1	0	2	0	10	0	10	0	3	0	3	0	5	2	7	22
08:00 AM	1	0	0	1	5	5	0	10	0	2	0	2	0	3	4	7	20
08:15 AM	4	0	0	4	1	7	0	8	0	6	0	6	1	7	0	8	26
08:30 AM	1	1	0	2	1	14	0	15	0	4	0	4	0	2	0	2	23
Total Volume	7	2	0	9	7	36	0	43	0	15	0	15	1	17	6	24	91
% App. Total	77.8	22.2	0		16.3	83.7	0		0	100	0		4.2	70.8	25		
PHF	.438	.500	.000	.563	.350	.643	.000	.717	.000	.625	.000	.625	.250	.607	.375	.750	.875

Traffic Data Service

Campbell, CA
(408) 377-2988
tdsbay@cs.com

File Name : 93AM FINAL
Site Code : 00000093
Start Date : 6/4/2013
Page No : 2

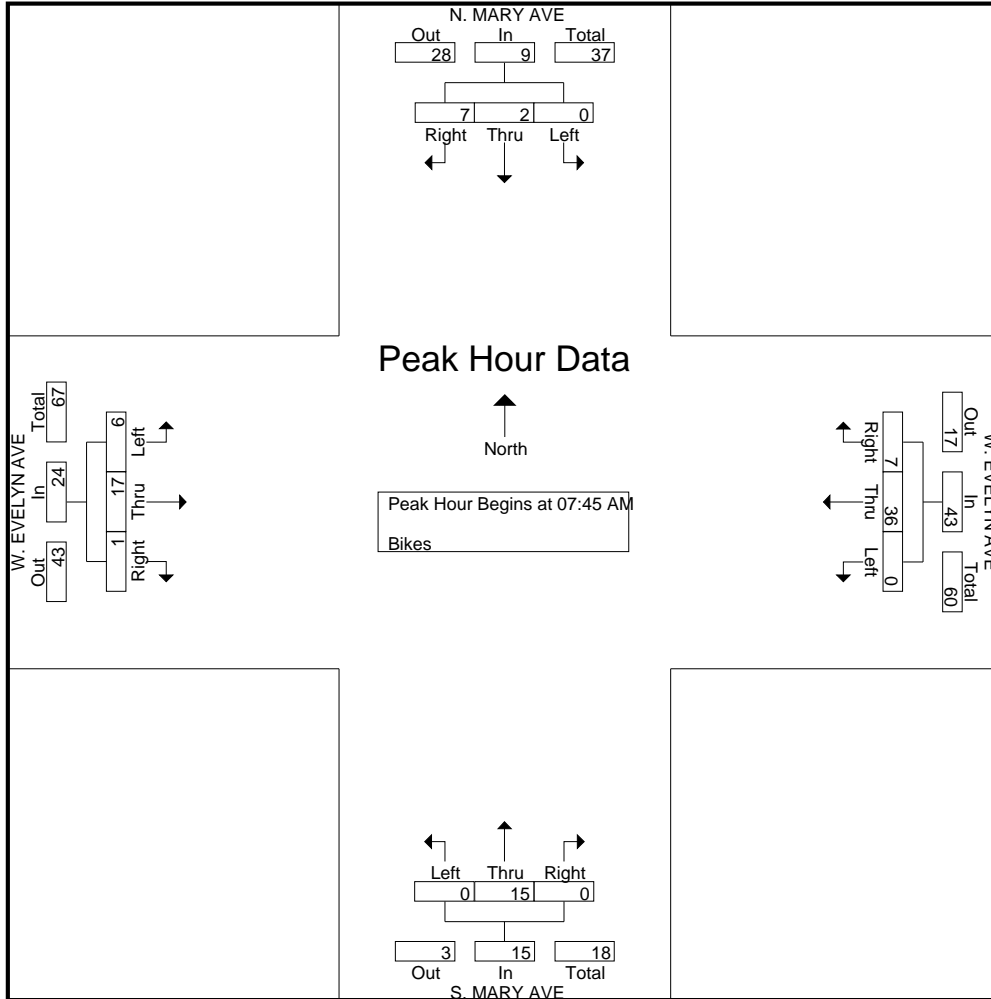

Traffic Data Service

Campbell, CA
 (408) 377-2988
 tdsbay@cs.com

File Name : 93PM FINAL
 Site Code : 00000093
 Start Date : 6/4/2013
 Page No : 1

Groups Printed- Vehicles

Start Time	N. MARY AVE Southbound					W. EVELYN AVE Westbound					S. MARY AVE Northbound					W. EVELYN AVE Eastbound					Int. Total
	Right	Thru	Left	Peds	App. Total	Right	Thru	Left	Peds	App. Total	Right	Thru	Left	Peds	App. Total	Right	Thru	Left	Peds	App. Total	
04:00 PM	40	151	18	0	209	17	27	15	1	60	5	85	6	0	96	11	42	48	1	102	467
04:15 PM	58	165	29	0	252	26	47	12	2	87	7	97	4	0	108	7	53	40	1	101	548
04:30 PM	45	165	24	0	234	19	39	9	6	73	16	82	7	3	108	15	55	48	5	123	538
04:45 PM	51	209	26	0	286	19	53	21	7	100	5	73	9	4	91	20	58	43	2	123	600
Total	194	690	97	0	981	81	166	57	16	320	33	337	26	7	403	53	208	179	9	449	2153
05:00 PM	68	305	39	0	412	26	51	10	3	90	8	99	7	2	116	16	70	70	4	160	778
05:15 PM	66	341	49	0	456	24	45	15	2	86	8	95	11	1	115	17	95	43	1	156	813
05:30 PM	74	381	40	0	495	23	45	23	3	94	7	96	9	2	114	28	84	60	9	181	884
05:45 PM	85	288	29	1	403	21	45	11	2	79	8	98	9	5	120	25	65	52	2	144	746
Total	293	1315	157	1	1766	94	186	59	10	349	31	388	36	10	465	86	314	225	16	641	3221
Grand Total	487	2005	254	1	2747	175	352	116	26	669	64	725	62	17	868	139	522	404	25	1090	5374
Apprch %	17.7	73	9.2	0		26.2	52.6	17.3	3.9		7.4	83.5	7.1	2		12.8	47.9	37.1	2.3		
Total %	9.1	37.3	4.7	0	51.1	3.3	6.6	2.2	0.5	12.4	1.2	13.5	1.2	0.3	16.2	2.6	9.7	7.5	0.5	20.3	

Start Time	N. MARY AVE Southbound				W. EVELYN AVE Westbound				S. MARY AVE Northbound				W. EVELYN AVE Eastbound				Int. Total
	Right	Thru	Left	App. Total	Right	Thru	Left	App. Total	Right	Thru	Left	App. Total	Right	Thru	Left	App. Total	
Peak Hour Analysis From 04:00 PM to 05:45 PM - Peak 1 of 1																	
Peak Hour for Entire Intersection Begins at 05:00 PM																	
05:00 PM	68	305	39	412	26	51	10	87	8	99	7	114	16	70	70	156	769
05:15 PM	66	341	49	456	24	45	15	84	8	95	11	114	17	95	43	155	809
05:30 PM	74	381	40	495	23	45	23	91	7	96	9	112	28	84	60	172	870
05:45 PM	85	288	29	402	21	45	11	77	8	98	9	115	25	65	52	142	736
Total Volume	293	1315	157	1765	94	186	59	339	31	388	36	455	86	314	225	625	3184
% App. Total	16.6	74.5	8.9		27.7	54.9	17.4		6.8	85.3	7.9		13.8	50.2	36		
PHF	.862	.863	.801	.891	.904	.912	.641	.931	.969	.980	.818	.989	.768	.826	.804	.908	.915

Traffic Data Service

Campbell, CA
(408) 377-2988
tdsbay@cs.com

File Name : 93PM FINAL
Site Code : 00000093
Start Date : 6/4/2013
Page No : 2

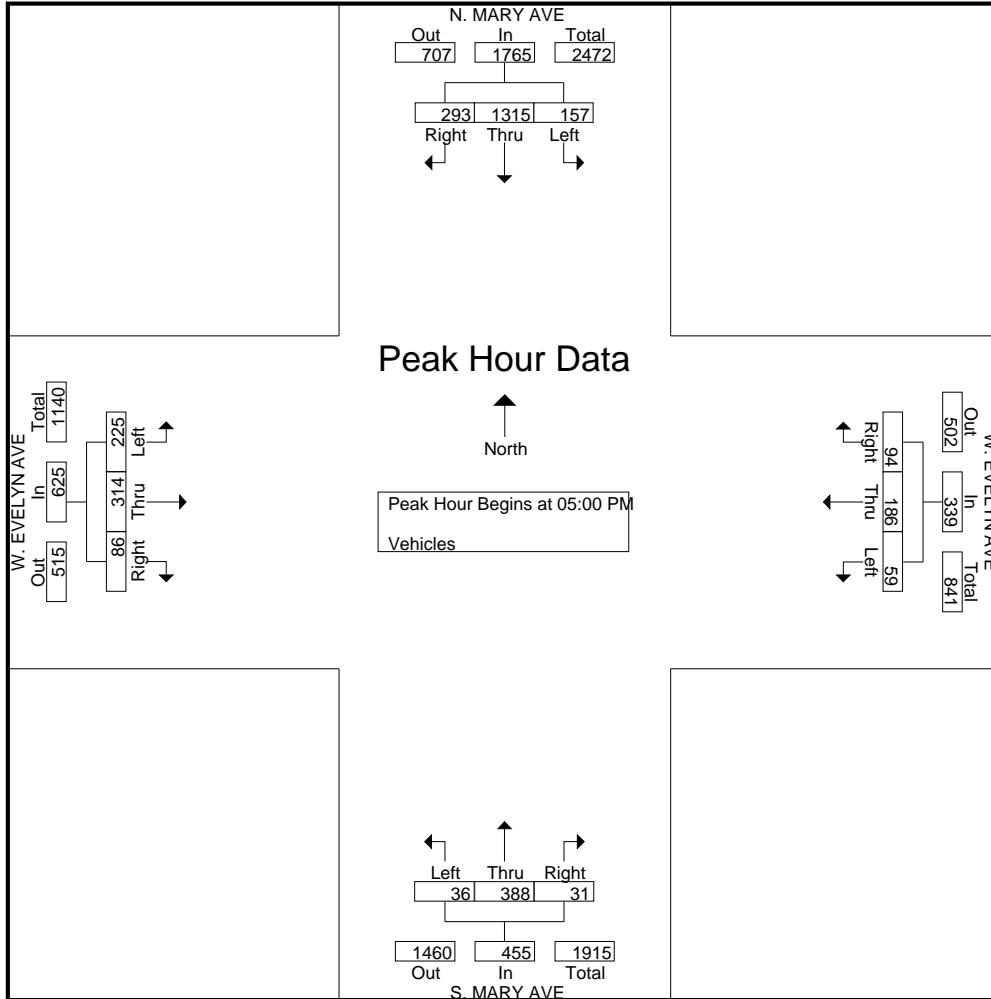

Traffic Data Service

Campbell, CA
 (408) 377-2988
 tdsbay@cs.com

File Name : 93PM FINAL
 Site Code : 00000093
 Start Date : 6/4/2013
 Page No : 1

Groups Printed- Bikes

Start Time	N. MARY AVE Southbound					W. EVELYN AVE Westbound					S. MARY AVE Northbound					W. EVELYN AVE Eastbound					Int. Total
	Right	Thru	Left	Peds	App. Total	Right	Thru	Left	Peds	App. Total	Right	Thru	Left	Peds	App. Total	Right	Thru	Left	Peds	App. Total	
04:00 PM	0	1	0	0	1	0	0	0	0	0	0	0	0	0	0	0	1	1	0	2	3
04:15 PM	2	2	0	0	4	0	1	0	0	1	0	1	0	0	1	0	2	0	0	2	8
04:30 PM	1	3	1	0	5	1	3	0	0	4	0	0	0	0	0	0	3	1	0	4	13
04:45 PM	2	2	1	0	5	0	2	0	0	2	0	0	0	0	0	1	1	0	0	2	9
Total	5	8	2	0	15	1	6	0	0	7	0	1	0	0	1	1	7	2	0	10	33
05:00 PM	1	1	3	0	5	2	3	0	0	5	0	0	0	0	0	0	6	1	0	7	17
05:15 PM	2	4	1	0	7	0	10	0	0	10	0	0	0	0	0	0	6	2	0	8	25
05:30 PM	4	2	1	0	7	0	3	0	0	3	1	0	0	0	1	0	8	0	0	8	19
05:45 PM	5	2	3	0	10	0	4	1	0	5	0	0	0	0	0	0	8	0	0	8	23
Total	12	9	8	0	29	2	20	1	0	23	1	0	0	0	1	0	28	3	0	31	84
Grand Total	17	17	10	0	44	3	26	1	0	30	1	1	0	0	2	1	35	5	0	41	117
Apprch %	38.6	38.6	22.7	0		10	86.7	3.3	0		50	50	0	0		2.4	85.4	12.2	0		
Total %	14.5	14.5	8.5	0	37.6	2.6	22.2	0.9	0	25.6	0.9	0.9	0	0	1.7	0.9	29.9	4.3	0	35	

Start Time	N. MARY AVE Southbound				W. EVELYN AVE Westbound				S. MARY AVE Northbound				W. EVELYN AVE Eastbound				Int. Total
	Right	Thru	Left	App. Total	Right	Thru	Left	App. Total	Right	Thru	Left	App. Total	Right	Thru	Left	App. Total	
05:00 PM	1	1	3	5	2	3	0	5	0	0	0	0	0	6	1	7	17
05:15 PM	2	4	1	7	0	10	0	10	0	0	0	0	0	6	2	8	25
05:30 PM	4	2	1	7	0	3	0	3	1	0	0	1	0	8	0	8	19
05:45 PM	5	2	3	10	0	4	1	5	0	0	0	0	0	8	0	8	23
Total Volume	12	9	8	29	2	20	1	23	1	0	0	1	0	28	3	31	84
% App. Total	41.4	31	27.6		8.7	87	4.3		100	0	0		0	90.3	9.7		
PHF	.600	.563	.667	.725	.250	.500	.250	.575	.250	.000	.000	.250	.000	.875	.375	.969	.840

Peak Hour Analysis From 04:00 PM to 05:45 PM - Peak 1 of 1

Peak Hour for Entire Intersection Begins at 05:00 PM

Traffic Data Service

Campbell, CA

(408) 377-2988

tdsbay@cs.com

File Name : 93PM FINAL

Site Code : 00000093

Start Date : 6/4/2013

Page No : 2

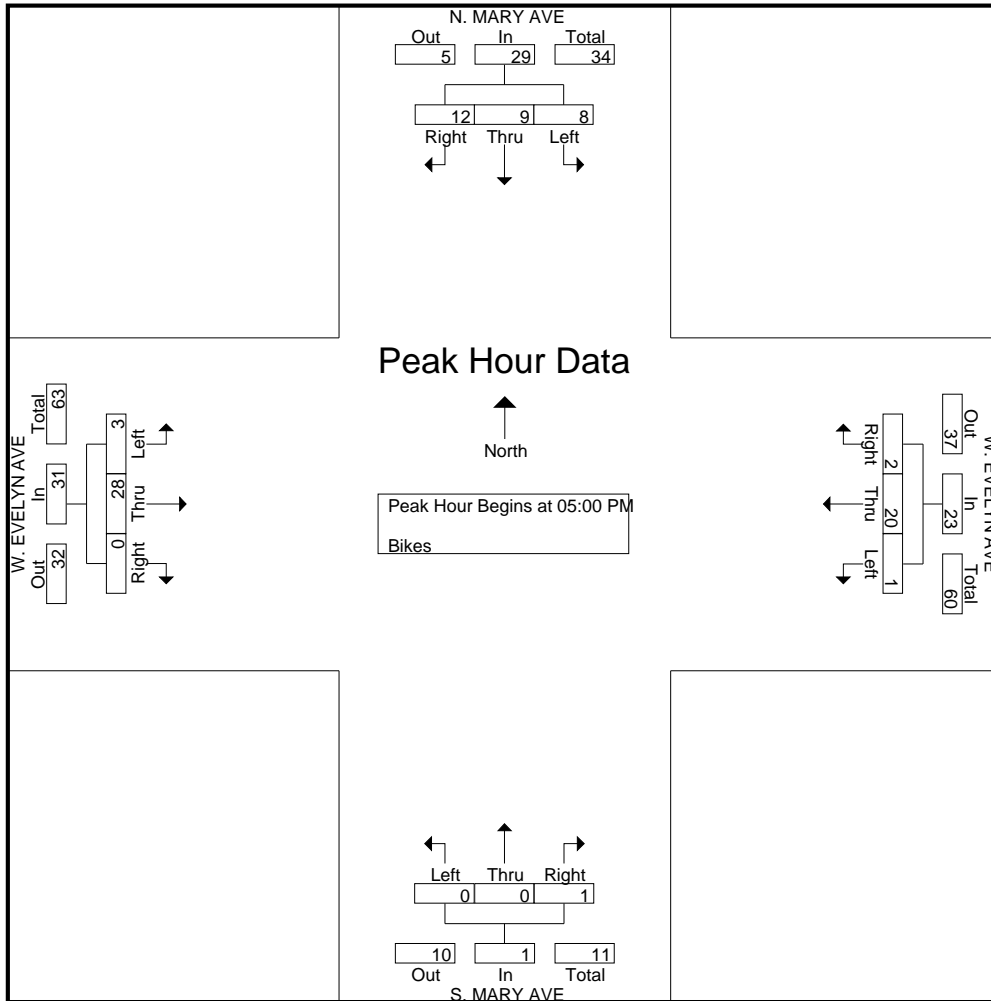

Traffic Data Service

Campbell, CA
 (408) 377-2988
 tdsbay@cs.com

File Name : 6AM FINAL
 Site Code : 00000006
 Start Date : 9/24/2013
 Page No : 1

Groups Printed- Vehicles

Start Time	CALTRAIN DW Southbound					W EVELYN AVE Westbound					S FRANCES ST Northbound					W EVELYN AVE Eastbound					Int. Total
	Right	Thru	Left	Peds	App. Total	Right	Thru	Left	Peds	App. Total	Right	Thru	Left	Peds	App. Total	Right	Thru	Left	Peds	App. Total	
07:00 AM	8	2	19	0	29	39	47	4	21	111	2	4	6	5	17	2	17	20	3	42	199
07:15 AM	8	0	11	0	19	9	60	2	11	82	5	2	2	4	13	3	27	13	0	43	157
07:30 AM	7	1	8	2	18	14	73	2	5	94	0	2	1	2	5	1	24	10	5	40	157
07:45 AM	12	4	17	2	35	24	86	3	22	135	2	9	5	2	18	3	47	35	18	103	291
Total	35	7	55	4	101	86	266	11	59	422	9	17	14	13	53	9	115	78	26	228	804
08:00 AM	16	8	27	1	52	36	128	15	28	207	2	8	2	7	19	9	50	17	2	78	356
08:15 AM	15	3	15	4	37	33	131	8	18	190	3	4	5	4	16	7	50	9	9	75	318
08:30 AM	11	3	10	0	24	17	116	5	1	139	1	0	2	1	4	2	41	7	9	59	226
08:45 AM	10	2	13	2	27	25	120	11	19	175	2	1	6	8	17	6	50	10	18	84	303
Total	52	16	65	7	140	111	495	39	66	711	8	13	15	20	56	24	191	43	38	296	1203
Grand Total	87	23	120	11	241	197	761	50	125	1133	17	30	29	33	109	33	306	121	64	524	2007
Apprch %	36.1	9.5	49.8	4.6		17.4	67.2	4.4	11		15.6	27.5	26.6	30.3		6.3	58.4	23.1	12.2		
Total %	4.3	1.1	6	0.5	12	9.8	37.9	2.5	6.2	56.5	0.8	1.5	1.4	1.6	5.4	1.6	15.2	6	3.2	26.1	

Start Time	CALTRAIN DW Southbound				W EVELYN AVE Westbound				S FRANCES ST Northbound				W EVELYN AVE Eastbound				Int. Total
	Right	Thru	Left	App. Total	Right	Thru	Left	App. Total	Right	Thru	Left	App. Total	Right	Thru	Left	App. Total	
Peak Hour Analysis From 07:00 AM to 08:45 AM - Peak 1 of 1																	
Peak Hour for Entire Intersection Begins at 08:00 AM																	
08:00 AM	16	8	27	51	36	128	15	179	2	8	2	12	9	50	17	76	318
08:15 AM	15	3	15	33	33	131	8	172	3	4	5	12	7	50	9	66	283
08:30 AM	11	3	10	24	17	116	5	138	1	0	2	3	2	41	7	50	215
08:45 AM	10	2	13	25	25	120	11	156	2	1	6	9	6	50	10	66	256
Total Volume	52	16	65	133	111	495	39	645	8	13	15	36	24	191	43	258	1072
% App. Total	39.1	12	48.9		17.2	76.7	6		22.2	36.1	41.7		9.3	74	16.7		
PHF	.813	.500	.602	.652	.771	.945	.650	.901	.667	.406	.625	.750	.667	.955	.632	.849	.843

Traffic Data Service

Campbell, CA
 (408) 377-2988
 tdsbay@cs.com

File Name : 6AM FINAL
 Site Code : 00000006
 Start Date : 9/24/2013
 Page No : 2

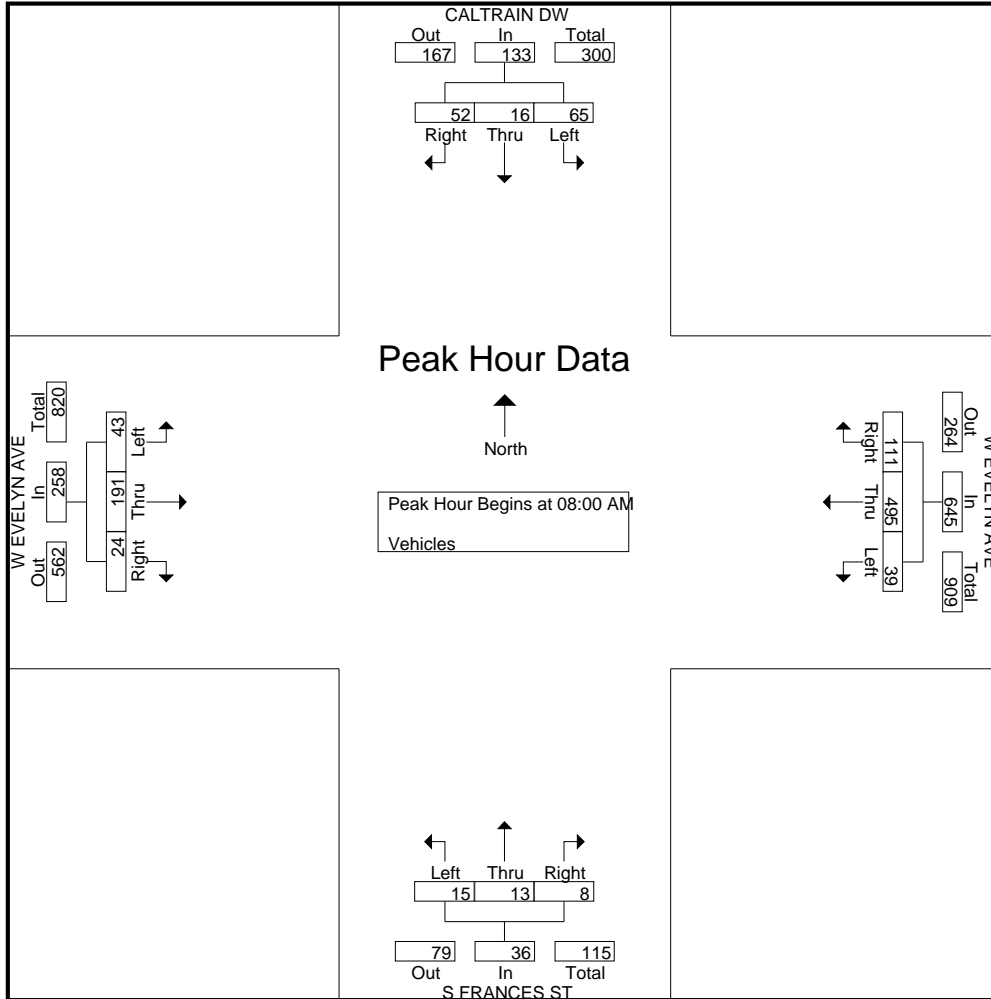

Traffic Data Service

Campbell, CA
 (408) 377-2988
 tdsbay@cs.com

File Name : 6AM FINAL
 Site Code : 00000006
 Start Date : 9/24/2013
 Page No : 1

Groups Printed- Bikes

Start Time	CALTRAIN DW Southbound					W EVELYN AVE Westbound					S FRANCES ST Northbound					W EVELYN AVE Eastbound					Int. Total
	Right	Thru	Left	Peds	App. Total	Right	Thru	Left	Peds	App. Total	Right	Thru	Left	Peds	App. Total	Right	Thru	Left	Peds	App. Total	
07:00 AM	0	0	0	0	0	0	8	0	0	8	0	0	0	0	0	0	3	0	0	3	11
07:15 AM	0	0	0	0	0	0	7	0	0	7	0	0	0	0	0	0	1	0	0	1	8
07:30 AM	0	0	0	0	0	1	5	0	0	6	0	0	0	0	0	0	4	0	0	4	10
07:45 AM	0	0	0	0	0	0	9	0	0	9	0	1	0	0	1	0	8	0	0	8	18
Total	0	0	0	0	0	1	29	0	0	30	0	1	0	0	1	0	16	0	0	16	47
08:00 AM	0	0	0	0	0	0	9	0	0	9	0	0	0	0	0	1	6	0	0	7	16
08:15 AM	0	0	0	0	0	2	9	0	0	11	0	1	0	0	1	0	7	0	0	7	19
08:30 AM	0	1	1	0	2	3	11	0	0	14	0	0	0	0	0	0	0	0	0	0	16
08:45 AM	0	0	5	0	5	0	11	0	0	11	0	1	1	0	2	0	8	0	0	8	26
Total	0	1	6	0	7	5	40	0	0	45	0	2	1	0	3	1	21	0	0	22	77
Grand Total	0	1	6	0	7	6	69	0	0	75	0	3	1	0	4	1	37	0	0	38	124
Apprch %	0	14.3	85.7	0		8	92	0	0		0	75	25	0		2.6	97.4	0	0		
Total %	0	0.8	4.8	0	5.6	4.8	55.6	0	0	60.5	0	2.4	0.8	0	3.2	0.8	29.8	0	0	30.6	

Start Time	CALTRAIN DW Southbound				W EVELYN AVE Westbound				S FRANCES ST Northbound				W EVELYN AVE Eastbound				Int. Total
	Right	Thru	Left	App. Total	Right	Thru	Left	App. Total	Right	Thru	Left	App. Total	Right	Thru	Left	App. Total	
Peak Hour Analysis From 07:00 AM to 08:45 AM - Peak 1 of 1																	
Peak Hour for Entire Intersection Begins at 08:00 AM																	
08:00 AM	0	0	0	0	0	9	0	9	0	0	0	0	1	6	0	7	16
08:15 AM	0	0	0	0	2	9	0	11	0	1	0	1	0	7	0	7	19
08:30 AM	0	1	1	2	3	11	0	14	0	0	0	0	0	0	0	0	16
08:45 AM	0	0	5	5	0	11	0	11	0	1	1	2	0	8	0	8	26
Total Volume	0	1	6	7	5	40	0	45	0	2	1	3	1	21	0	22	77
% App. Total	0	14.3	85.7		11.1	88.9	0		0	66.7	33.3		4.5	95.5	0		
PHF	.000	.250	.300	.350	.417	.909	.000	.804	.000	.500	.250	.375	.250	.656	.000	.688	.740

Traffic Data Service

Campbell, CA
 (408) 377-2988
 tdsbay@cs.com

File Name : 6AM FINAL
 Site Code : 00000006
 Start Date : 9/24/2013
 Page No : 2

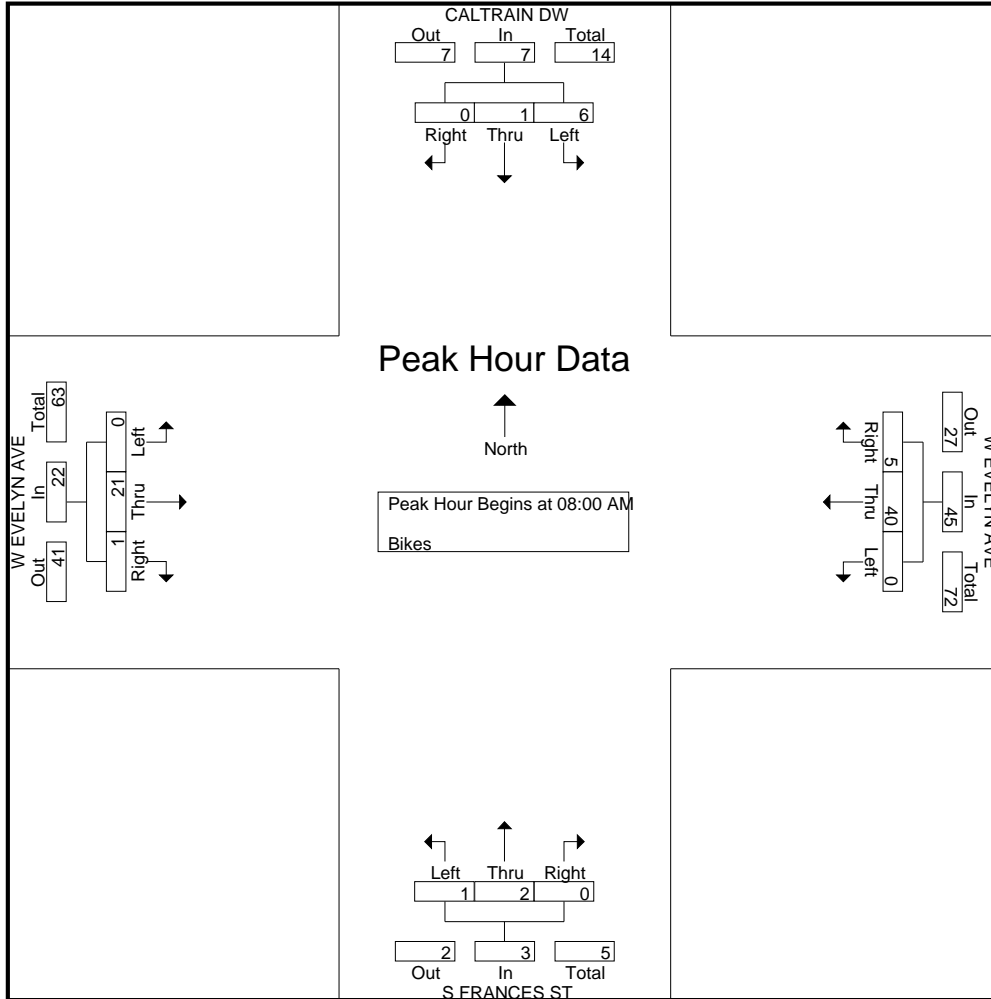

Traffic Data Service

Campbell, CA
 (408) 377-2988
 tdsbay@cs.com

File Name : 6PM FINAL
 Site Code : 00000006
 Start Date : 9/24/2013
 Page No : 1

Groups Printed- Vehicles

Start Time	CALTRAIN DW Southbound					W EVELYN AVE Westbound					S FRANCES ST Northbound					W EVELYN AVE Eastbound					Int. Total
	Right	Thru	Left	Peds	App. Total	Right	Thru	Left	Peds	App. Total	Right	Thru	Left	Peds	App. Total	Right	Thru	Left	Peds	App. Total	
04:00 PM	4	0	3	2	9	5	51	6	11	73	7	0	5	4	16	5	52	2	4	63	161
04:15 PM	9	3	13	4	29	7	69	6	11	93	1	2	5	6	14	14	70	3	17	104	240
04:30 PM	5	1	5	1	12	15	56	9	15	95	3	1	4	3	11	10	70	8	2	90	208
04:45 PM	12	4	16	5	37	9	65	12	16	102	5	3	7	5	20	24	85	6	14	129	288
Total	30	8	37	12	87	36	241	33	53	363	16	6	21	18	61	53	277	19	37	386	897
05:00 PM	7	2	3	2	14	16	72	10	5	103	5	2	6	0	13	18	95	3	1	117	247
05:15 PM	25	11	33	8	77	21	111	31	30	193	5	5	5	4	19	16	120	12	20	168	457
05:30 PM	4	2	17	0	23	12	78	20	5	115	6	2	8	5	21	16	126	11	7	160	319
05:45 PM	8	1	18	0	27	20	78	12	20	130	1	5	5	3	14	18	130	10	21	179	350
Total	44	16	71	10	141	69	339	73	60	541	17	14	24	12	67	68	471	36	49	624	1373
Grand Total	74	24	108	22	228	105	580	106	113	904	33	20	45	30	128	121	748	55	86	1010	2270
Apprch %	32.5	10.5	47.4	9.6		11.6	64.2	11.7	12.5		25.8	15.6	35.2	23.4		12	74.1	5.4	8.5		
Total %	3.3	1.1	4.8	1	10	4.6	25.6	4.7	5	39.8	1.5	0.9	2	1.3	5.6	5.3	33	2.4	3.8	44.5	

Start Time	CALTRAIN DW Southbound				W EVELYN AVE Westbound				S FRANCES ST Northbound				W EVELYN AVE Eastbound				Int. Total
	Right	Thru	Left	App. Total	Right	Thru	Left	App. Total	Right	Thru	Left	App. Total	Right	Thru	Left	App. Total	
Peak Hour Analysis From 04:00 PM to 05:45 PM - Peak 1 of 1																	
Peak Hour for Entire Intersection Begins at 05:00 PM																	
05:00 PM	7	2	3	12	16	72	10	98	5	2	6	13	18	95	3	116	239
05:15 PM	25	11	33	69	21	111	31	163	5	5	5	15	16	120	12	148	395
05:30 PM	4	2	17	23	12	78	20	110	6	2	8	16	16	126	11	153	302
05:45 PM	8	1	18	27	20	78	12	110	1	5	5	11	18	130	10	158	306
Total Volume	44	16	71	131	69	339	73	481	17	14	24	55	68	471	36	575	1242
% App. Total	33.6	12.2	54.2		14.3	70.5	15.2		30.9	25.5	43.6		11.8	81.9	6.3		
PHF	.440	.364	.538	.475	.821	.764	.589	.738	.708	.700	.750	.859	.944	.906	.750	.910	.786

Traffic Data Service

Campbell, CA
 (408) 377-2988
 tdsbay@cs.com

File Name : 6PM FINAL
 Site Code : 00000006
 Start Date : 9/24/2013
 Page No : 2

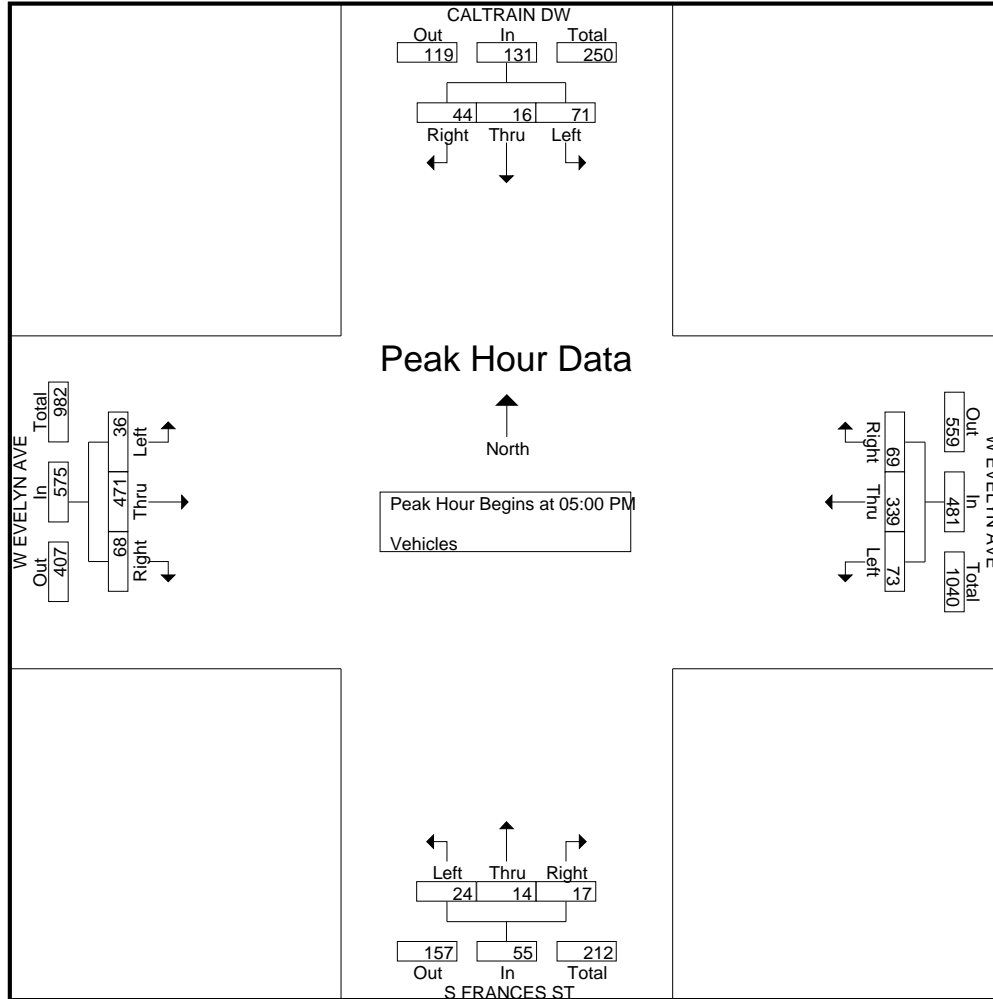

Traffic Data Service

Campbell, CA
 (408) 377-2988
 tdsbay@cs.com

File Name : 6PM FINAL
 Site Code : 00000006
 Start Date : 9/24/2013
 Page No : 1

Groups Printed- Bikes

Start Time	CALTRAIN DW Southbound					W EVELYN AVE Westbound					S FRANCES ST Northbound					W EVELYN AVE Eastbound					Int. Total
	Right	Thru	Left	Peds	App. Total	Right	Thru	Left	Peds	App. Total	Right	Thru	Left	Peds	App. Total	Right	Thru	Left	Peds	App. Total	
04:00 PM	0	0	0	0	0	0	1	0	0	1	0	0	0	0	0	0	0	0	0	0	1
04:15 PM	0	0	1	0	1	0	1	0	0	1	0	0	0	0	0	0	0	0	0	0	2
04:30 PM	0	0	0	0	0	0	4	0	0	4	0	1	0	0	1	0	2	0	0	2	7
04:45 PM	0	0	0	0	0	0	3	0	0	3	0	1	0	0	1	0	3	0	0	3	7
Total	0	0	1	0	1	0	9	0	0	9	0	2	0	0	2	0	5	0	0	5	17
05:00 PM	0	0	0	0	0	2	3	0	0	5	0	0	0	0	0	0	9	0	0	9	14
05:15 PM	0	3	7	0	10	0	3	0	0	3	0	0	0	0	0	0	7	0	0	7	20
05:30 PM	0	0	2	0	2	1	5	0	0	6	0	0	0	0	0	0	12	0	0	12	20
05:45 PM	0	1	5	0	6	0	4	0	0	4	0	1	0	0	1	0	9	0	0	9	20
Total	0	4	14	0	18	3	15	0	0	18	0	1	0	0	1	0	37	0	0	37	74
Grand Total	0	4	15	0	19	3	24	0	0	27	0	3	0	0	3	0	42	0	0	42	91
Apprch %	0	21.1	78.9	0		11.1	88.9	0	0		0	100	0	0		0	100	0	0		
Total %	0	4.4	16.5	0	20.9	3.3	26.4	0	0	29.7	0	3.3	0	0	3.3	0	46.2	0	0	46.2	

Start Time	CALTRAIN DW Southbound				W EVELYN AVE Westbound				S FRANCES ST Northbound				W EVELYN AVE Eastbound				Int. Total
	Right	Thru	Left	App. Total	Right	Thru	Left	App. Total	Right	Thru	Left	App. Total	Right	Thru	Left	App. Total	
Peak Hour Analysis From 04:00 PM to 05:45 PM - Peak 1 of 1																	
Peak Hour for Entire Intersection Begins at 05:00 PM																	
05:00 PM	0	0	0	0	2	3	0	5	0	0	0	0	0	9	0	9	14
05:15 PM	0	3	7	10	0	3	0	3	0	0	0	0	0	7	0	7	20
05:30 PM	0	0	2	2	1	5	0	6	0	0	0	0	0	12	0	12	20
05:45 PM	0	1	5	6	0	4	0	4	0	1	0	1	0	9	0	9	20
Total Volume	0	4	14	18	3	15	0	18	0	1	0	1	0	37	0	37	74
% App. Total	0	22.2	77.8		16.7	83.3	0		0	100	0		0	100	0		
PHF	.000	.333	.500	.450	.375	.750	.000	.750	.000	.250	.000	.250	.000	.771	.000	.771	.925

Traffic Data Service

Campbell, CA
 (408) 377-2988
 tdsbay@cs.com

File Name : 6PM FINAL
 Site Code : 00000006
 Start Date : 9/24/2013
 Page No : 2

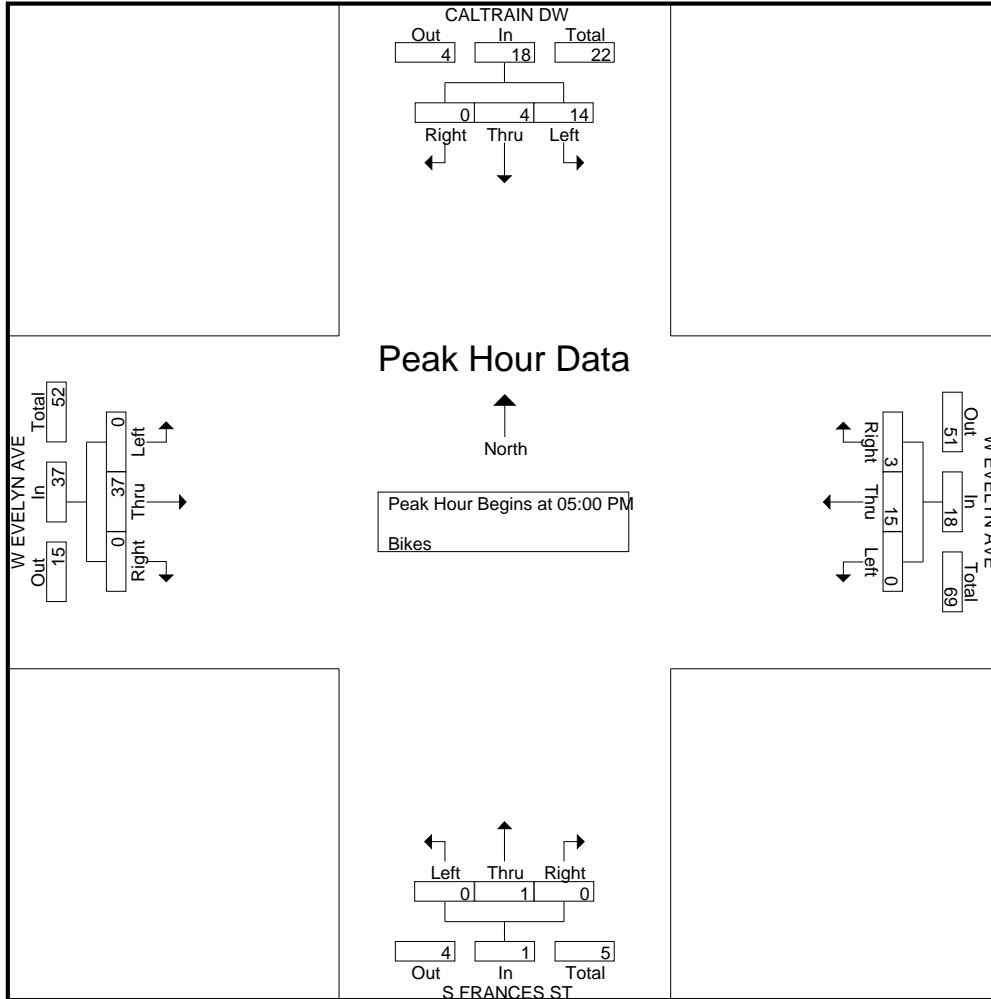

Traffic Data Service

Campbell, CA
 (408) 377-2988
 tdsbay@cs.com

File Name : 96AM FINAL
 Site Code : 00000096
 Start Date : 6/5/2013
 Page No : 1

Groups Printed- Vehicles

Start Time	LAWRENCE EXPY Southbound					KIFER RD Westbound					LAWRENCE EXPY Northbound					KIFER RD Eastbound					Int. Total
	Right	Thru	Left	Peds	App. Total	Right	Thru	Left	Peds	App. Total	Right	Thru	Left	Peds	App. Total	Right	Thru	Left	Peds	App. Total	
07:00 AM	80	193	45	0	318	16	17	3	1	37	73	493	44	0	610	17	6	17	0	40	1005
07:15 AM	72	237	34	0	343	16	21	6	0	43	79	648	37	0	764	11	11	18	0	40	1190
07:30 AM	74	286	40	0	400	13	33	22	0	68	72	698	54	0	824	11	15	20	0	46	1338
07:45 AM	85	370	70	0	525	12	32	22	1	67	93	881	58	0	1032	26	24	18	0	68	1692
Total	311	1086	189	0	1586	57	103	53	2	215	317	2720	193	0	3230	65	56	73	0	194	5225
08:00 AM	104	314	74	0	492	24	33	14	1	72	99	1102	92	0	1293	23	25	34	1	83	1940
08:15 AM	93	365	54	0	512	26	37	20	1	84	168	1129	56	0	1353	50	32	32	1	115	2064
08:30 AM	93	292	36	0	421	28	42	18	0	88	120	1174	43	0	1337	40	33	21	0	94	1940
08:45 AM	105	305	46	0	456	23	43	18	0	84	136	1148	57	0	1341	38	55	23	0	116	1997
Total	395	1276	210	0	1881	101	155	70	2	328	523	4553	248	0	5324	151	145	110	2	408	7941
Grand Total	706	2362	399	0	3467	158	258	123	4	543	840	7273	441	0	8554	216	201	183	2	602	13166
Apprch %	20.4	68.1	11.5	0		29.1	47.5	22.7	0.7		9.8	85	5.2	0		35.9	33.4	30.4	0.3		
Total %	5.4	17.9	3	0	26.3	1.2	2	0.9	0	4.1	6.4	55.2	3.3	0	65	1.6	1.5	1.4	0	4.6	

Start Time	LAWRENCE EXPY Southbound				KIFER RD Westbound				LAWRENCE EXPY Northbound				KIFER RD Eastbound				Int. Total
	Right	Thru	Left	App. Total	Right	Thru	Left	App. Total	Right	Thru	Left	App. Total	Right	Thru	Left	App. Total	
Peak Hour Analysis From 07:00 AM to 08:45 AM - Peak 1 of 1																	
Peak Hour for Entire Intersection Begins at 08:00 AM																	
08:00 AM	104	314	74	492	24	33	14	71	99	1102	92	1293	23	25	34	82	1938
08:15 AM	93	365	54	512	26	37	20	83	168	1129	56	1353	50	32	32	114	2062
08:30 AM	93	292	36	421	28	42	18	88	120	1174	43	1337	40	33	21	94	1940
08:45 AM	105	305	46	456	23	43	18	84	136	1148	57	1341	38	55	23	116	1997
Total Volume	395	1276	210	1881	101	155	70	326	523	4553	248	5324	151	145	110	406	7937
% App. Total	21	67.8	11.2		31	47.5	21.5		9.8	85.5	4.7		37.2	35.7	27.1		
PHF	.940	.874	.709	.918	.902	.901	.875	.926	.778	.970	.674	.984	.755	.659	.809	.875	.962

Traffic Data Service

Campbell, CA

(408) 377-2988

tdsbay@cs.com

File Name : 96AM FINAL

Site Code : 00000096

Start Date : 6/5/2013

Page No : 2

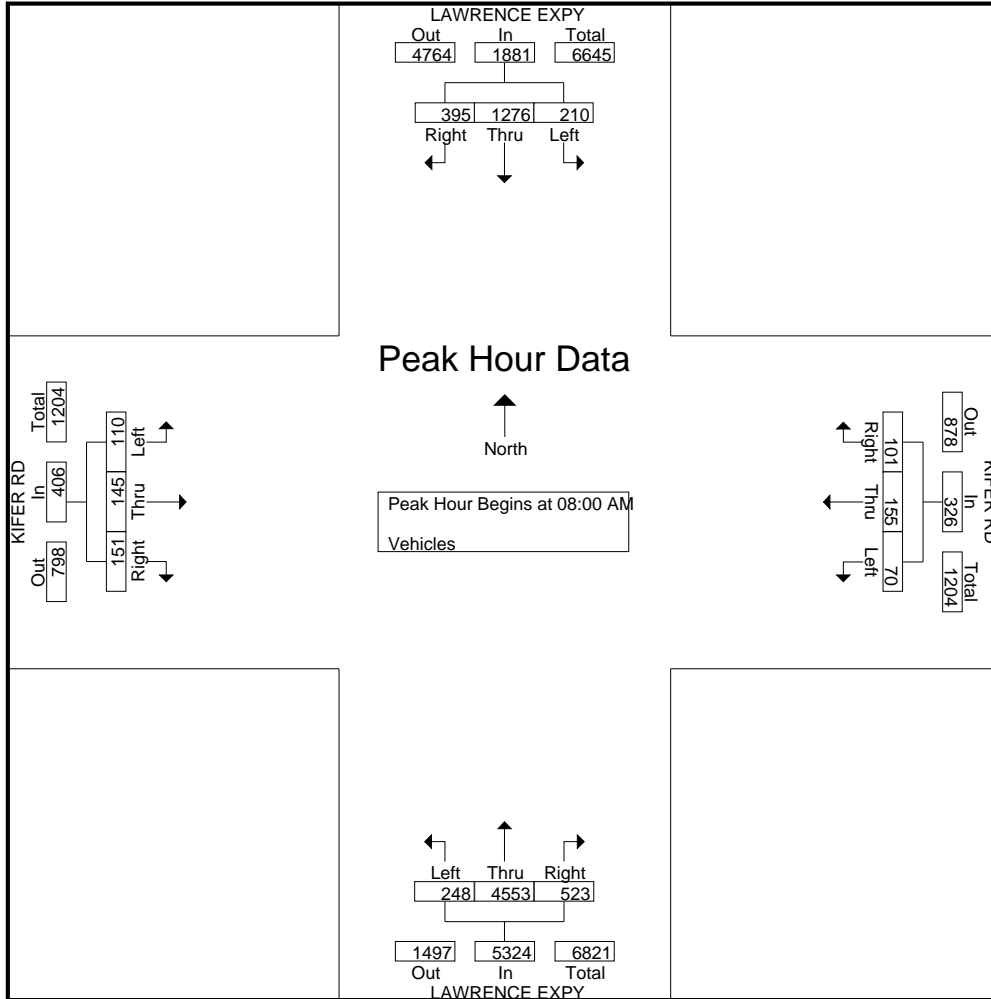

Traffic Data Service

Campbell, CA
 (408) 377-2988
 tdsbay@cs.com

File Name : 96AM FINAL
 Site Code : 00000096
 Start Date : 6/5/2013
 Page No : 1

Groups Printed- Bikes

Start Time	LAWRENCE EXPY Southbound					KIFER RD Westbound					LAWRENCE EXPY Northbound					KIFER RD Eastbound					Int. Total
	Right	Thru	Left	Peds	App. Total	Right	Thru	Left	Peds	App. Total	Right	Thru	Left	Peds	App. Total	Right	Thru	Left	Peds	App. Total	
07:00 AM	0	0	0	0	0	0	0	0	0	0	0	2	0	0	2	0	0	0	0	0	2
07:15 AM	0	0	0	0	0	0	0	0	0	0	3	3	0	0	6	0	3	2	0	5	11
07:30 AM	0	0	0	0	0	0	0	0	0	0	2	1	0	0	3	0	1	0	0	1	4
07:45 AM	0	0	0	0	0	0	0	0	0	0	2	1	0	0	3	0	2	0	0	2	5
Total	0	0	0	0	0	0	0	0	0	0	7	7	0	0	14	0	6	2	0	8	22
08:00 AM	0	0	0	0	0	0	0	0	0	0	0	2	0	0	2	0	0	0	0	0	2
08:15 AM	0	0	0	0	0	0	0	0	0	0	2	5	1	0	8	0	1	0	0	1	9
08:30 AM	0	0	0	0	0	0	0	0	0	0	0	3	0	0	3	0	3	0	0	3	6
08:45 AM	0	0	0	0	0	0	0	0	0	0	1	2	2	0	5	0	1	0	0	1	6
Total	0	0	0	0	0	0	0	0	0	0	3	12	3	0	18	0	5	0	0	5	23
Grand Total	0	0	0	0	0	0	0	0	0	0	10	19	3	0	32	0	11	2	0	13	45
Apprch %	0	0	0	0	0	0	0	0	0	0	31.2	59.4	9.4	0		0	84.6	15.4	0		
Total %	0	0	0	0	0	0	0	0	0	0	22.2	42.2	6.7	0	71.1	0	24.4	4.4	0	28.9	

Start Time	LAWRENCE EXPY Southbound				KIFER RD Westbound				LAWRENCE EXPY Northbound				KIFER RD Eastbound				Int. Total
	Right	Thru	Left	App. Total	Right	Thru	Left	App. Total	Right	Thru	Left	App. Total	Right	Thru	Left	App. Total	
08:00 AM	0	0	0	0	0	0	0	0	0	2	0	2	0	0	0	0	2
08:15 AM	0	0	0	0	0	0	0	0	2	5	1	8	0	1	0	1	9
08:30 AM	0	0	0	0	0	0	0	0	0	3	0	3	0	3	0	3	6
08:45 AM	0	0	0	0	0	0	0	0	1	2	2	5	0	1	0	1	6
Total Volume	0	0	0	0	0	0	0	0	3	12	3	18	0	5	0	5	23
% App. Total	0	0	0	0	0	0	0	0	16.7	66.7	16.7		0	100	0		
PHF	.000	.000	.000	.000	.000	.000	.000	.000	.375	.600	.375	.563	.000	.417	.000	.417	.639

Peak Hour Analysis From 07:00 AM to 08:45 AM - Peak 1 of 1

Peak Hour for Entire Intersection Begins at 08:00 AM

Traffic Data Service

Campbell, CA
(408) 377-2988
tdsbay@cs.com

File Name : 96AM FINAL
Site Code : 00000096
Start Date : 6/5/2013
Page No : 2

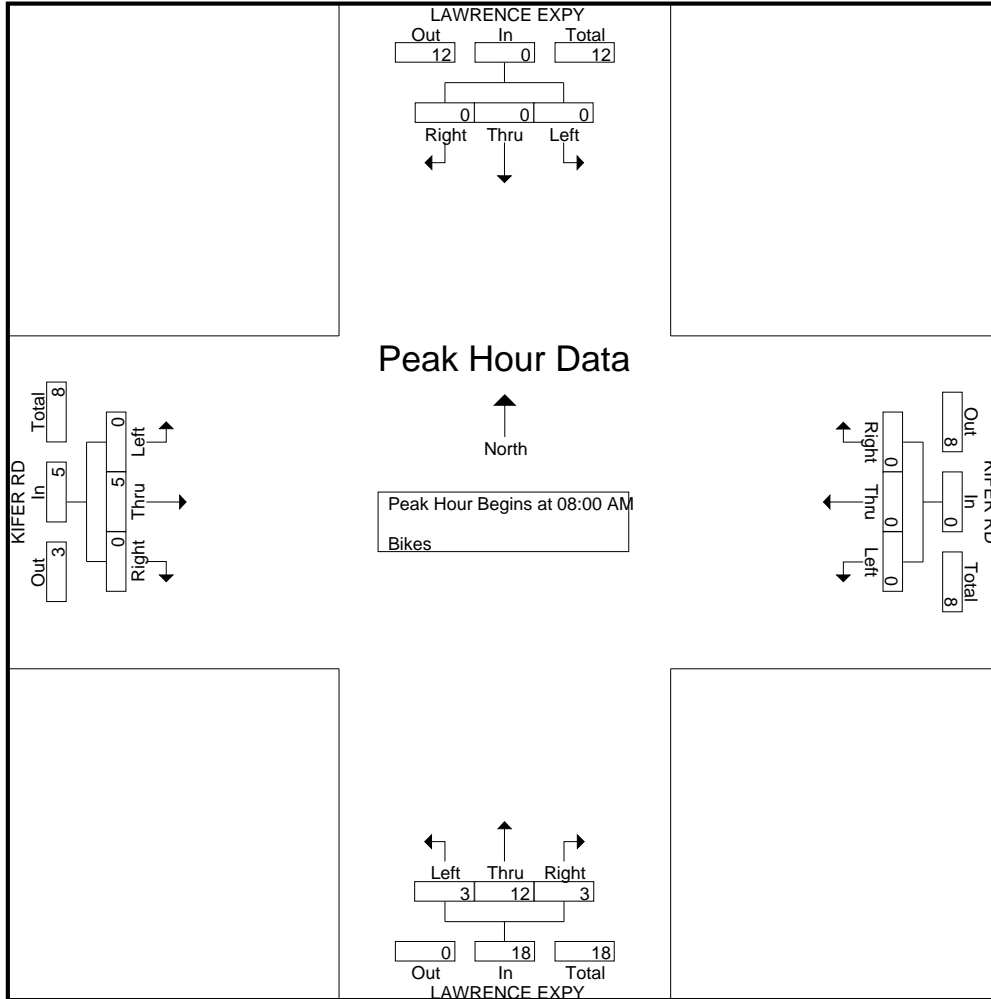

Traffic Data Service

Campbell, CA
 (408) 377-2988
 tdsbay@cs.com

File Name : 96PM FINAL
 Site Code : 00000096
 Start Date : 6/5/2013
 Page No : 1

Groups Printed- Vehicles

Start Time	LAWRENCE EXPY Southbound					KIFER RD Westbound					LAWRENCE EXPY Northbound					KIFER RD Eastbound					Int. Total
	Right	Thru	Left	Peds	App. Total	Right	Thru	Left	Peds	App. Total	Right	Thru	Left	Peds	App. Total	Right	Thru	Left	Peds	App. Total	
04:00 PM	21	427	40	0	488	40	55	58	2	155	116	394	6	2	518	88	20	36	1	145	1306
04:15 PM	23	493	42	0	558	69	68	79	0	216	125	403	14	1	543	105	55	44	0	204	1521
04:30 PM	27	551	30	0	608	96	70	73	0	239	118	430	38	0	586	192	70	57	1	320	1753
04:45 PM	10	698	57	0	765	56	95	110	0	261	101	344	12	0	457	158	92	58	2	310	1793
Total	81	2169	169	0	2419	261	288	320	2	871	460	1571	70	3	2104	543	237	195	4	979	6373
05:00 PM	15	793	118	0	926	40	189	128	0	357	44	457	13	0	514	168	54	64	0	286	2083
05:15 PM	14	705	82	1	802	64	212	154	0	430	79	396	31	0	506	265	159	70	1	495	2233
05:30 PM	6	879	78	0	963	41	293	164	0	498	63	414	17	0	494	310	177	80	1	568	2523
05:45 PM	10	891	109	0	1010	44	198	153	0	395	59	518	23	1	601	335	144	62	1	542	2548
Total	45	3268	387	1	3701	189	892	599	0	1680	245	1785	84	1	2115	1078	534	276	3	1891	9387
Grand Total	126	5437	556	1	6120	450	1180	919	2	2551	705	3356	154	4	4219	1621	771	471	7	2870	15760
Apprch %	2.1	88.8	9.1	0		17.6	46.3	36	0.1		16.7	79.5	3.7	0.1		56.5	26.9	16.4	0.2		
Total %	0.8	34.5	3.5	0	38.8	2.9	7.5	5.8	0	16.2	4.5	21.3	1	0	26.8	10.3	4.9	3	0	18.2	

Start Time	LAWRENCE EXPY Southbound				KIFER RD Westbound				LAWRENCE EXPY Northbound				KIFER RD Eastbound				Int. Total
	Right	Thru	Left	App. Total	Right	Thru	Left	App. Total	Right	Thru	Left	App. Total	Right	Thru	Left	App. Total	
Peak Hour Analysis From 04:00 PM to 05:45 PM - Peak 1 of 1																	
Peak Hour for Entire Intersection Begins at 05:00 PM																	
05:00 PM	15	793	118	926	40	189	128	357	44	457	13	514	168	54	64	286	2083
05:15 PM	14	705	82	801	64	212	154	430	79	396	31	506	265	159	70	494	2231
05:30 PM	6	879	78	963	41	293	164	498	63	414	17	494	310	177	80	567	2522
05:45 PM	10	891	109	1010	44	198	153	395	59	518	23	600	335	144	62	541	2546
Total Volume	45	3268	387	3700	189	892	599	1680	245	1785	84	2114	1078	534	276	1888	9382
% App. Total	1.2	88.3	10.5		11.2	53.1	35.7		11.6	84.4	4		57.1	28.3	14.6		
PHF	.750	.917	.820	.916	.738	.761	.913	.843	.775	.861	.677	.881	.804	.754	.863	.832	.921

Traffic Data Service

Campbell, CA
 (408) 377-2988
 tdsbay@cs.com

File Name : 96PM FINAL
 Site Code : 00000096
 Start Date : 6/5/2013
 Page No : 2

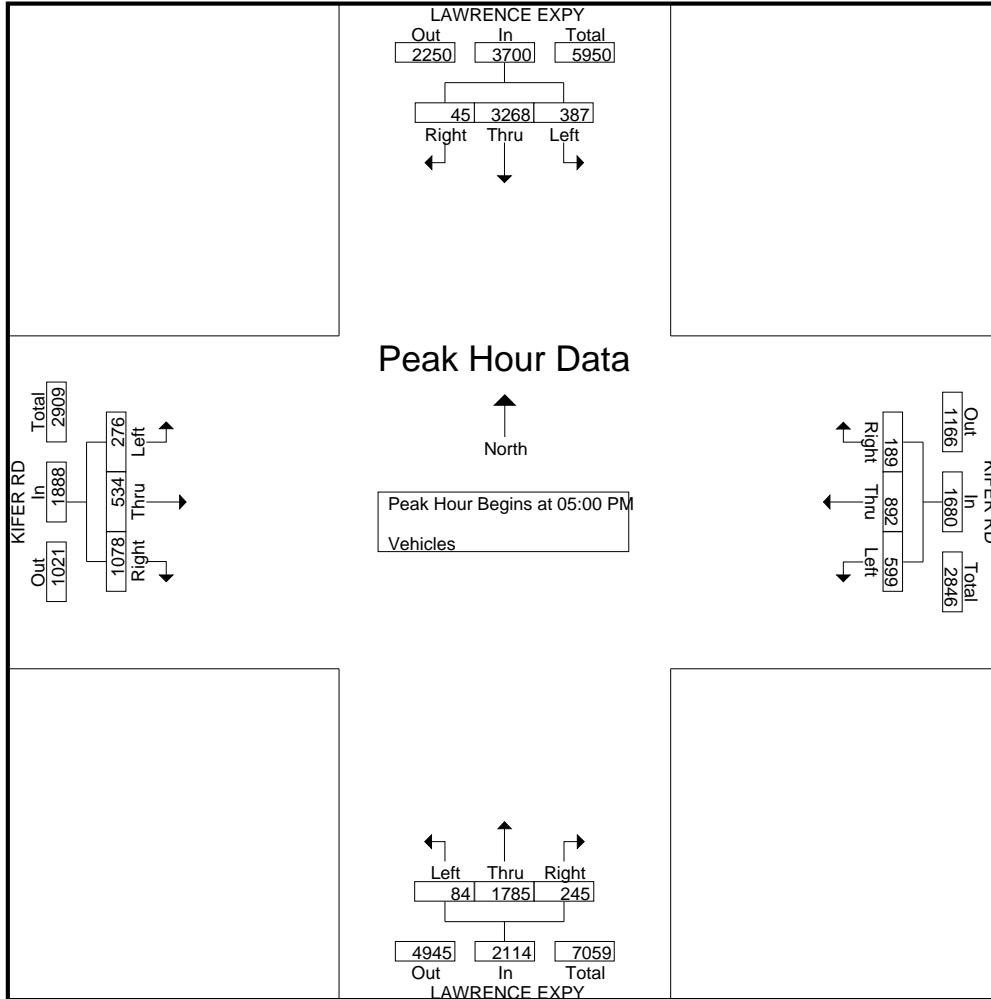

Traffic Data Service

Campbell, CA
 (408) 377-2988
 tdsbay@cs.com

File Name : 96PM FINAL
 Site Code : 00000096
 Start Date : 6/5/2013
 Page No : 1

Groups Printed- Bikes

Start Time	LAWRENCE EXPY Southbound					KIFER RD Westbound					LAWRENCE EXPY Northbound					KIFER RD Eastbound					Int. Total					
	Right	Thru	Left	Peds	App. Total	Right	Thru	Left	Peds	App. Total	Right	Thru	Left	Peds	App. Total	Right	Thru	Left	Peds	App. Total						
04:00 PM	0	0	0	0	0	0	0	0	0	0	0	0	0	0	0	0	0	0	0	0	0	0	0	0	0	0
04:15 PM	0	0	0	0	0	0	0	0	0	0	0	1	0	0	1	1	0	0	0	0	1	0	0	0	1	2
04:30 PM	0	0	0	0	0	0	0	0	0	0	0	0	0	0	0	0	0	0	0	0	0	0	0	0	0	0
04:45 PM	0	0	0	0	0	0	0	0	0	0	0	0	0	0	0	0	0	0	0	0	0	0	0	0	0	0
Total	0	0	0	0	0	0	0	0	0	0	0	1	0	0	1	1	0	0	0	0	1	0	0	0	1	2
05:00 PM	0	0	0	0	0	0	0	0	0	0	0	0	0	0	0	0	0	0	0	0	0	0	0	0	0	0
05:15 PM	0	0	0	0	0	0	0	0	0	0	0	0	0	0	0	0	15	0	0	15	15	0	0	0	15	15
05:30 PM	0	0	0	0	0	0	0	0	0	0	0	0	0	0	0	0	0	0	0	0	0	0	0	0	0	0
05:45 PM	0	0	0	0	0	0	0	0	0	0	0	0	0	0	0	0	1	0	0	1	1	0	0	0	1	1
Total	0	0	0	0	0	0	0	0	0	0	0	0	0	0	0	0	16	0	0	16	16	0	0	0	16	16
Grand Total	0	0	0	0	0	0	0	0	0	0	0	1	0	0	1	1	16	0	0	17	17	0	0	0	17	18
Apprch %	0	0	0	0	0	0	0	0	0	0	0	100	0	0	5.6	5.9	94.1	0	0	94.4	94.4	0	0	0	94.4	
Total %	0	0	0	0	0	0	0	0	0	0	0	5.6	0	0	5.6	5.6	88.9	0	0	94.4	94.4	0	0	0	94.4	

Start Time	LAWRENCE EXPY Southbound				KIFER RD Westbound				LAWRENCE EXPY Northbound				KIFER RD Eastbound				Int. Total				
	Right	Thru	Left	App. Total	Right	Thru	Left	App. Total	Right	Thru	Left	App. Total	Right	Thru	Left	App. Total					
05:00 PM	0	0	0	0	0	0	0	0	0	0	0	0	0	0	0	0	0	0	0	0	0
05:15 PM	0	0	0	0	0	0	0	0	0	0	0	0	0	15	0	15	15	0	0	0	15
05:30 PM	0	0	0	0	0	0	0	0	0	0	0	0	0	0	0	0	0	0	0	0	0
05:45 PM	0	0	0	0	0	0	0	0	0	0	0	0	0	1	0	1	1	0	0	0	1
Total Volume	0	0	0	0	0	0	0	0	0	0	0	0	0	16	0	16	16	0	0	0	16
% App. Total	0	0	0	0	0	0	0	0	0	0	0	0	0	100	0	94.4	94.4	0	0	0	94.4
PHF	.000	.000	.000	.000	.000	.000	.000	.000	.000	.000	.000	.000	.000	.267	.000	.267	.267	.000	.000	.000	.267

Peak Hour Analysis From 04:00 PM to 05:45 PM - Peak 1 of 1

Peak Hour for Entire Intersection Begins at 05:00 PM

Traffic Data Service

Campbell, CA

(408) 377-2988

tdsbay@cs.com

File Name : 96PM FINAL

Site Code : 00000096

Start Date : 6/5/2013

Page No : 2

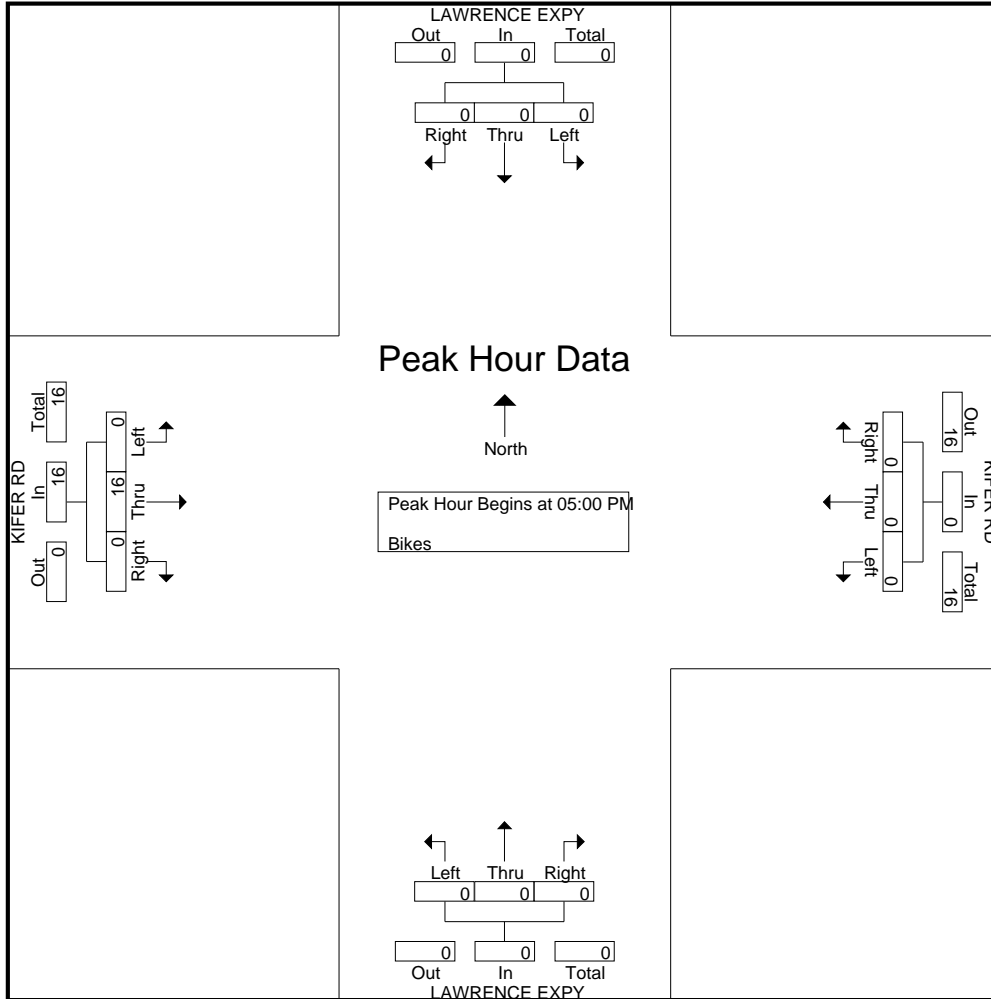

Traffic Data Service

Campbell, CA
 (408) 377-2988
 tdsbay@cs.com

File Name : 97AM FINAL
 Site Code : 00000097
 Start Date : 6/6/2013
 Page No : 1

Groups Printed- Vehicles

Start Time	LAWRENCE EXPY Southbound					MONROE ST Westbound					LAWRENCE EXPY Northbound					REED AVE Eastbound					Int. Total
	Right	Thru	Left	Peds	App. Total	Right	Thru	Left	Peds	App. Total	Right	Thru	Left	Peds	App. Total	Right	Thru	Left	Peds	App. Total	
07:00 AM	30	130	5	1	166	60	20	18	0	98	11	502	34	3	550	13	16	55	2	86	900
07:15 AM	37	185	10	0	232	76	47	28	0	151	10	519	16	1	546	32	20	52	0	104	1033
07:30 AM	31	239	20	1	291	64	32	35	3	134	27	744	19	0	790	32	29	104	0	165	1380
07:45 AM	45	261	36	0	342	66	86	116	2	270	52	815	37	13	917	57	138	142	5	342	1871
Total	143	815	71	2	1031	266	185	197	5	653	100	2580	106	17	2803	134	203	353	7	697	5184
08:00 AM	37	287	28	0	352	102	103	64	1	270	27	924	31	0	982	42	68	134	1	245	1849
08:15 AM	56	305	16	0	377	67	54	43	0	164	33	1144	42	1	1220	54	72	128	1	255	2016
08:30 AM	26	286	26	0	338	59	29	41	0	129	15	1182	40	1	1238	65	83	172	0	320	2025
08:45 AM	40	240	12	0	292	67	36	34	4	141	28	1199	83	0	1310	56	84	222	2	364	2107
Total	159	1118	82	0	1359	295	222	182	5	704	103	4449	196	2	4750	217	307	656	4	1184	7997
Grand Total	302	1933	153	2	2390	561	407	379	10	1357	203	7029	302	19	7553	351	510	1009	11	1881	13181
Apprch %	12.6	80.9	6.4	0.1		41.3	30	27.9	0.7		2.7	93.1	4	0.3		18.7	27.1	53.6	0.6		
Total %	2.3	14.7	1.2	0	18.1	4.3	3.1	2.9	0.1	10.3	1.5	53.3	2.3	0.1	57.3	2.7	3.9	7.7	0.1	14.3	

Start Time	LAWRENCE EXPY Southbound				MONROE ST Westbound				LAWRENCE EXPY Northbound				REED AVE Eastbound				Int. Total
	Right	Thru	Left	App. Total	Right	Thru	Left	App. Total	Right	Thru	Left	App. Total	Right	Thru	Left	App. Total	
Peak Hour Analysis From 07:00 AM to 08:45 AM - Peak 1 of 1																	
Peak Hour for Entire Intersection Begins at 08:00 AM																	
08:00 AM	37	287	28	352	102	103	64	269	27	924	31	982	42	68	134	244	1847
08:15 AM	56	305	16	377	67	54	43	164	33	1144	42	1219	54	72	128	254	2014
08:30 AM	26	286	26	338	59	29	41	129	15	1182	40	1237	65	83	172	320	2024
08:45 AM	40	240	12	292	67	36	34	137	28	1199	83	1310	56	84	222	362	2101
Total Volume	159	1118	82	1359	295	222	182	699	103	4449	196	4748	217	307	656	1180	7986
% App. Total	11.7	82.3	6		42.2	31.8	26		2.2	93.7	4.1		18.4	26	55.6		
PHF	.710	.916	.732	.901	.723	.539	.711	.650	.780	.928	.590	.906	.835	.914	.739	.815	.950

Traffic Data Service

Campbell, CA
 (408) 377-2988
 tdsbay@cs.com

File Name : 97AM FINAL
 Site Code : 00000097
 Start Date : 6/6/2013
 Page No : 2

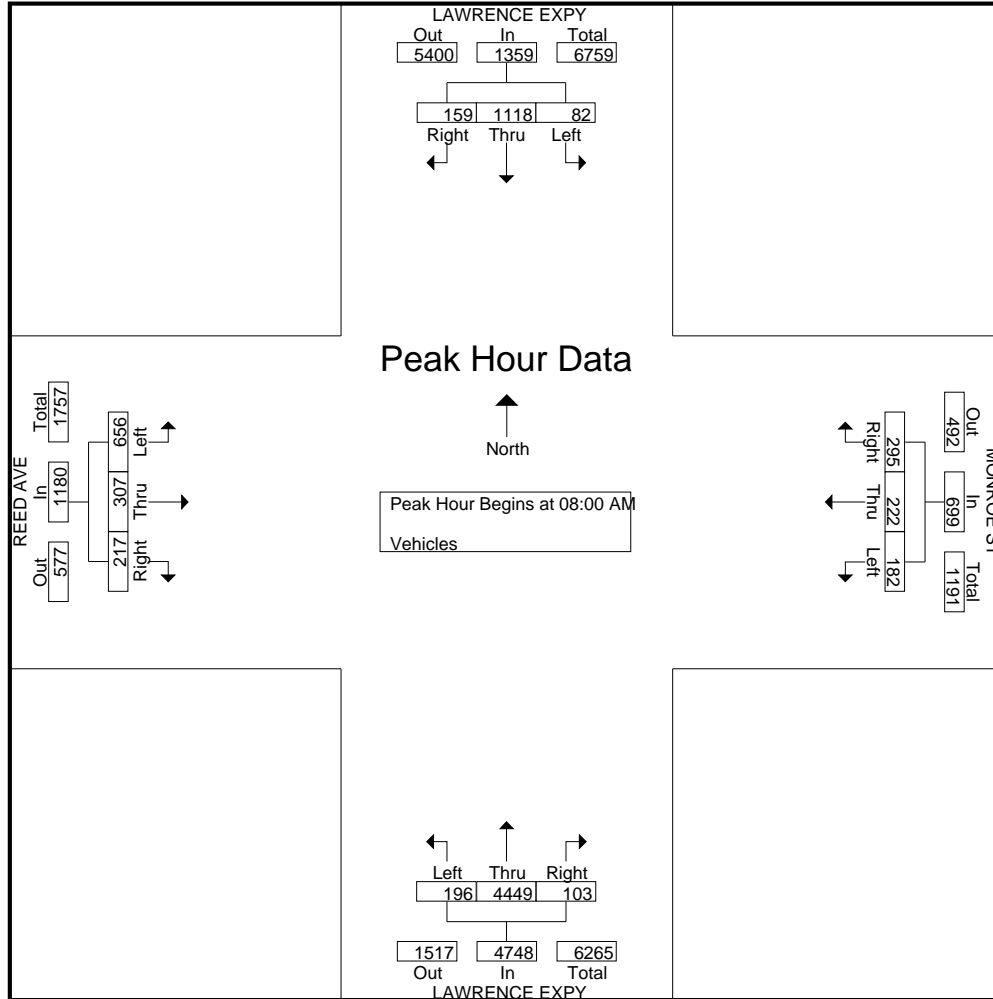

Traffic Data Service

Campbell, CA
 (408) 377-2988
 tdsbay@cs.com

File Name : 97AM FINAL
 Site Code : 00000097
 Start Date : 6/6/2013
 Page No : 1

Groups Printed- Bikes

Start Time	LAWRENCE EXPY Southbound					MONROE ST Westbound					LAWRENCE EXPY Northbound					REED AVE Eastbound					Int. Total
	Right	Thru	Left	Peds	App. Total	Right	Thru	Left	Peds	App. Total	Right	Thru	Left	Peds	App. Total	Right	Thru	Left	Peds	App. Total	
07:00 AM	0	0	0	0	0	0	3	0	0	3	0	0	0	0	0	0	1	0	0	1	4
07:15 AM	0	0	0	0	0	0	0	0	0	0	0	0	0	0	0	0	1	0	0	1	1
07:30 AM	0	0	0	0	0	0	0	0	0	0	0	2	0	0	2	0	1	0	0	1	3
07:45 AM	0	1	0	0	1	0	3	0	0	3	0	1	0	0	1	0	8	0	0	8	13
Total	0	1	0	0	1	0	6	0	0	6	0	3	0	0	3	0	11	0	0	11	21
08:00 AM	0	0	0	0	0	0	1	0	0	1	0	0	0	0	0	0	2	0	0	2	3
08:15 AM	0	2	0	0	2	0	5	0	0	5	0	3	0	0	3	1	1	0	0	2	12
08:30 AM	0	0	0	0	0	0	0	0	0	0	0	0	0	0	0	0	1	0	0	1	1
08:45 AM	0	0	0	0	0	0	0	0	0	0	0	2	0	0	2	0	1	0	0	1	3
Total	0	2	0	0	2	0	6	0	0	6	0	5	0	0	5	1	5	0	0	6	19
Grand Total	0	3	0	0	3	0	12	0	0	12	0	8	0	0	8	1	16	0	0	17	40
Apprch %	0	100	0	0		0	100	0	0		0	100	0	0		5.9	94.1	0	0		
Total %	0	7.5	0	0	7.5	0	30	0	0	30	0	20	0	0	20	2.5	40	0	0	42.5	

Start Time	LAWRENCE EXPY Southbound				MONROE ST Westbound				LAWRENCE EXPY Northbound				REED AVE Eastbound				Int. Total
	Right	Thru	Left	App. Total	Right	Thru	Left	App. Total	Right	Thru	Left	App. Total	Right	Thru	Left	App. Total	
Peak Hour Analysis From 07:00 AM to 08:45 AM - Peak 1 of 1																	
Peak Hour for Entire Intersection Begins at 07:30 AM																	
07:30 AM	0	0	0	0	0	0	0	0	0	2	0	2	0	1	0	1	3
07:45 AM	0	1	0	1	0	3	0	3	0	1	0	1	0	8	0	8	13
08:00 AM	0	0	0	0	0	1	0	1	0	0	0	0	0	2	0	2	3
08:15 AM	0	2	0	2	0	5	0	5	0	3	0	3	1	1	0	2	12
Total Volume	0	3	0	3	0	9	0	9	0	6	0	6	1	12	0	13	31
% App. Total	0	100	0		0	100	0		0	100	0		7.7	92.3	0		
PHF	.000	.375	.000	.375	.000	.450	.000	.450	.000	.500	.000	.500	.250	.375	.000	.406	.596

Traffic Data Service

Campbell, CA

(408) 377-2988

tdsbay@cs.com

File Name : 97AM FINAL

Site Code : 00000097

Start Date : 6/6/2013

Page No : 2

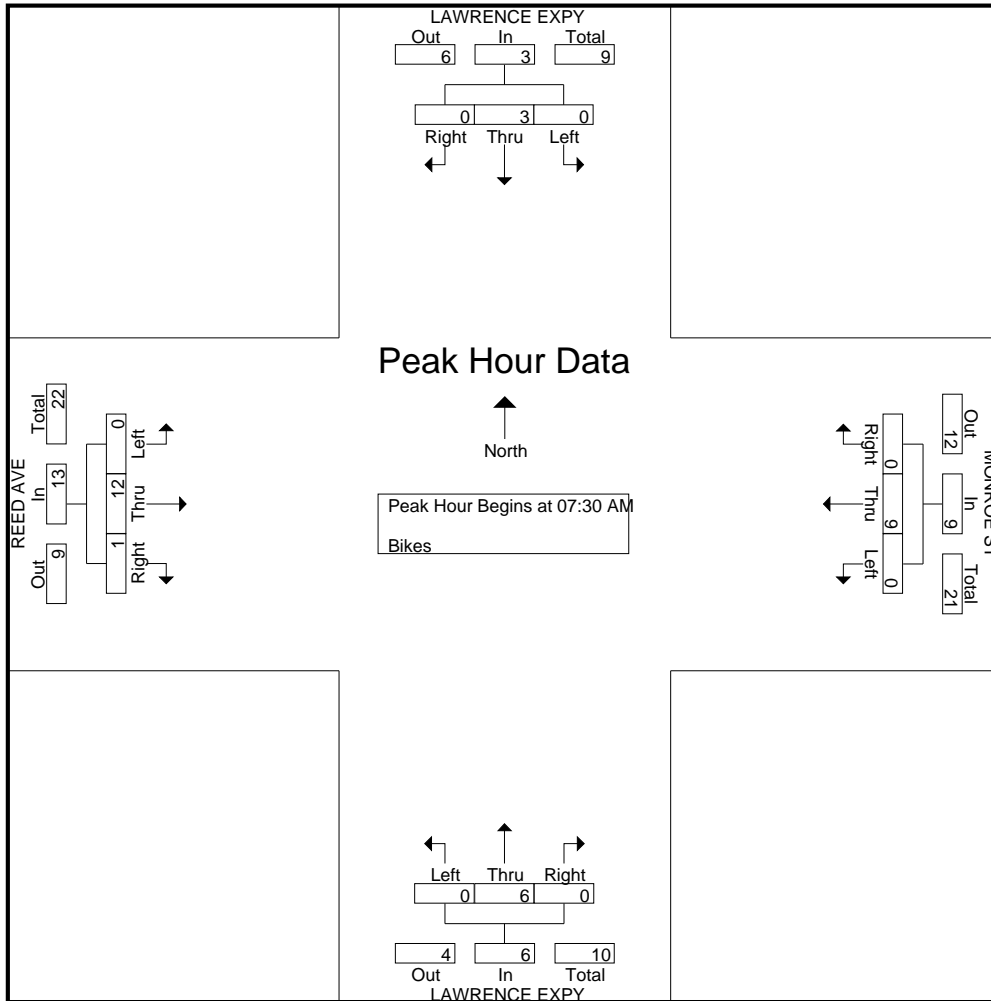

Traffic Data Service

Campbell, CA
 (408) 377-2988
 tdsbay@cs.com

File Name : 97PM FINAL
 Site Code : 00000097
 Start Date : 6/6/2013
 Page No : 1

Groups Printed- Vehicles

Start Time	LAWRENCE EXPY Southbound					MONROE ST Westbound					LAWRENCE EXPY Northbound					REED AVE Eastbound					Int. Total
	Right	Thru	Left	Peds	App. Total	Right	Thru	Left	Peds	App. Total	Right	Thru	Left	Peds	App. Total	Right	Thru	Left	Peds	App. Total	
04:00 PM	95	622	49	0	766	16	29	34	0	79	34	445	50	1	530	42	52	60	0	154	1529
04:15 PM	80	807	41	0	928	17	43	40	0	100	38	384	30	2	454	59	58	74	0	191	1673
04:30 PM	63	821	95	0	979	14	66	44	1	125	55	373	57	0	485	58	72	81	0	211	1800
04:45 PM	57	845	140	0	1042	4	87	63	0	154	63	389	65	1	518	75	73	108	0	256	1970
Total	295	3095	325	0	3715	51	225	181	1	458	190	1591	202	4	1987	234	255	323	0	812	6972
05:00 PM	53	836	173	0	1062	11	43	41	2	97	61	360	65	3	489	67	89	76	0	232	1880
05:15 PM	74	807	151	0	1032	17	64	91	0	172	67	389	63	6	525	80	139	84	0	303	2032
05:30 PM	78	894	125	1	1098	22	71	122	3	218	114	408	76	1	599	100	188	111	0	399	2314
05:45 PM	131	1148	154	0	1433	20	119	88	0	227	100	517	65	0	682	115	137	92	2	346	2688
Total	336	3685	603	1	4625	70	297	342	5	714	342	1674	269	10	2295	362	553	363	2	1280	8914
Grand Total	631	6780	928	1	8340	121	522	523	6	1172	532	3265	471	14	4282	596	808	686	2	2092	15886
Apprch %	7.6	81.3	11.1	0		10.3	44.5	44.6	0.5		12.4	76.2	11	0.3		28.5	38.6	32.8	0.1		
Total %	4	42.7	5.8	0	52.5	0.8	3.3	3.3	0	7.4	3.3	20.6	3	0.1	27	3.8	5.1	4.3	0	13.2	

Start Time	LAWRENCE EXPY Southbound				MONROE ST Westbound				LAWRENCE EXPY Northbound				REED AVE Eastbound				Int. Total
	Right	Thru	Left	App. Total	Right	Thru	Left	App. Total	Right	Thru	Left	App. Total	Right	Thru	Left	App. Total	
Peak Hour Analysis From 04:00 PM to 05:45 PM - Peak 1 of 1																	
Peak Hour for Entire Intersection Begins at 05:00 PM																	
05:00 PM	53	836	173	1062	11	43	41	95	61	360	65	486	67	89	76	232	1875
05:15 PM	74	807	151	1032	17	64	91	172	67	389	63	519	80	139	84	303	2026
05:30 PM	78	894	125	1097	22	71	122	215	114	408	76	598	100	188	111	399	2309
05:45 PM	131	1148	154	1433	20	119	88	227	100	517	65	682	115	137	92	344	2686
Total Volume	336	3685	603	4624	70	297	342	709	342	1674	269	2285	362	553	363	1278	8896
% App. Total	7.3	79.7	13		9.9	41.9	48.2		15	73.3	11.8		28.3	43.3	28.4		
PHF	.641	.802	.871	.807	.795	.624	.701	.781	.750	.809	.885	.838	.787	.735	.818	.801	.828

Traffic Data Service

Campbell, CA
 (408) 377-2988
 tdsbay@cs.com

File Name : 97PM FINAL
 Site Code : 00000097
 Start Date : 6/6/2013
 Page No : 2

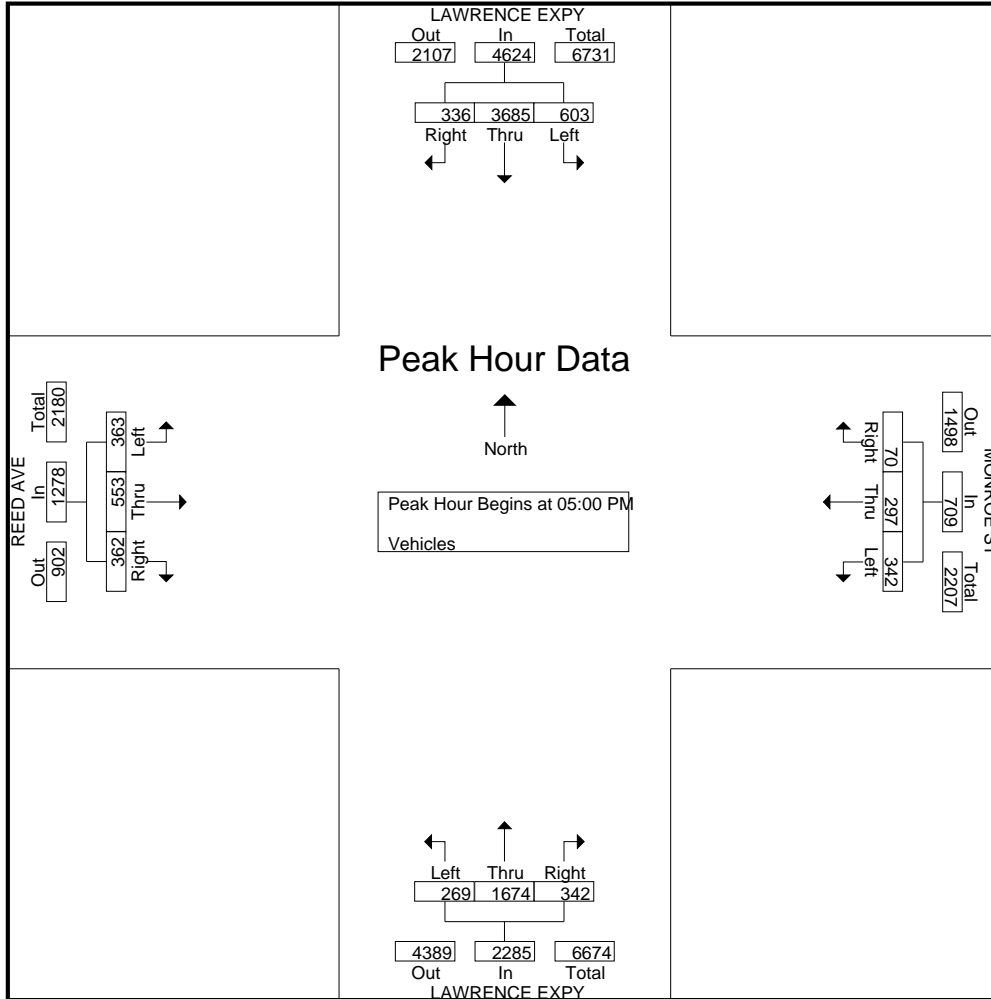

Traffic Data Service

Campbell, CA
 (408) 377-2988
 tdsbay@cs.com

File Name : 97PM FINAL
 Site Code : 00000097
 Start Date : 6/6/2013
 Page No : 1

Groups Printed- Bikes

Start Time	LAWRENCE EXPY Southbound					MONROE ST Westbound					LAWRENCE EXPY Northbound					REED AVE Eastbound					Int. Total
	Right	Thru	Left	Peds	App. Total	Right	Thru	Left	Peds	App. Total	Right	Thru	Left	Peds	App. Total	Right	Thru	Left	Peds	App. Total	
04:00 PM	0	0	0	0	0	1	3	0	0	4	0	0	0	0	0	0	1	0	0	1	5
04:15 PM	0	0	0	0	0	0	0	0	0	0	0	1	0	0	1	0	1	0	0	1	2
04:30 PM	0	0	0	0	0	0	2	0	0	2	0	0	0	0	0	1	4	0	0	5	7
04:45 PM	0	1	0	0	1	0	0	0	0	0	0	0	0	0	0	0	1	0	0	1	2
Total	0	1	0	0	1	1	5	0	0	6	0	1	0	0	1	1	7	0	0	8	16
05:00 PM	0	0	0	0	0	0	0	0	0	0	0	0	0	0	0	0	1	0	0	1	1
05:15 PM	0	1	0	0	1	0	0	0	0	0	0	1	1	0	2	0	4	0	0	4	7
05:30 PM	0	1	0	0	1	1	1	0	0	2	0	0	0	0	0	0	4	0	0	4	7
05:45 PM	0	0	0	0	0	0	1	0	0	1	0	3	1	0	4	0	1	0	0	1	6
Total	0	2	0	0	2	1	2	0	0	3	0	4	2	0	6	0	10	0	0	10	21
Grand Total	0	3	0	0	3	2	7	0	0	9	0	5	2	0	7	1	17	0	0	18	37
Apprch %	0	100	0	0		22.2	77.8	0	0		0	71.4	28.6	0		5.6	94.4	0	0		
Total %	0	8.1	0	0	8.1	5.4	18.9	0	0	24.3	0	13.5	5.4	0	18.9	2.7	45.9	0	0	48.6	

Start Time	LAWRENCE EXPY Southbound					MONROE ST Westbound					LAWRENCE EXPY Northbound					REED AVE Eastbound					Int. Total
	Right	Thru	Left	Peds	App. Total	Right	Thru	Left	Peds	App. Total	Right	Thru	Left	Peds	App. Total	Right	Thru	Left	Peds	App. Total	
Peak Hour Analysis From 04:00 PM to 05:45 PM - Peak 1 of 1																					
Peak Hour for Entire Intersection Begins at 05:00 PM																					
05:00 PM	0	0	0	0	0	0	0	0	0	0	0	0	0	0	0	0	1	0	0	1	1
05:15 PM	0	1	0	0	1	0	0	0	0	0	0	1	1	0	2	0	4	0	0	4	7
05:30 PM	0	1	0	0	1	1	1	0	0	2	0	0	0	0	0	0	4	0	0	4	7
05:45 PM	0	0	0	0	0	0	1	0	0	1	0	3	1	0	4	0	1	0	0	1	6
Total Volume	0	2	0	0	2	1	2	0	0	3	0	4	2	0	6	0	10	0	0	10	21
% App. Total	0	100	0	0		33.3	66.7	0	0		0	66.7	33.3	0		0	100	0	0		
PHF	.000	.500	.000	.000	.500	.250	.500	.000	.000	.375	.000	.333	.500	.375	.000	.625	.000	.000	.625	.750	

Traffic Data Service

Campbell, CA
(408) 377-2988
tdsbay@cs.com

File Name : 97PM FINAL
Site Code : 00000097
Start Date : 6/6/2013
Page No : 2

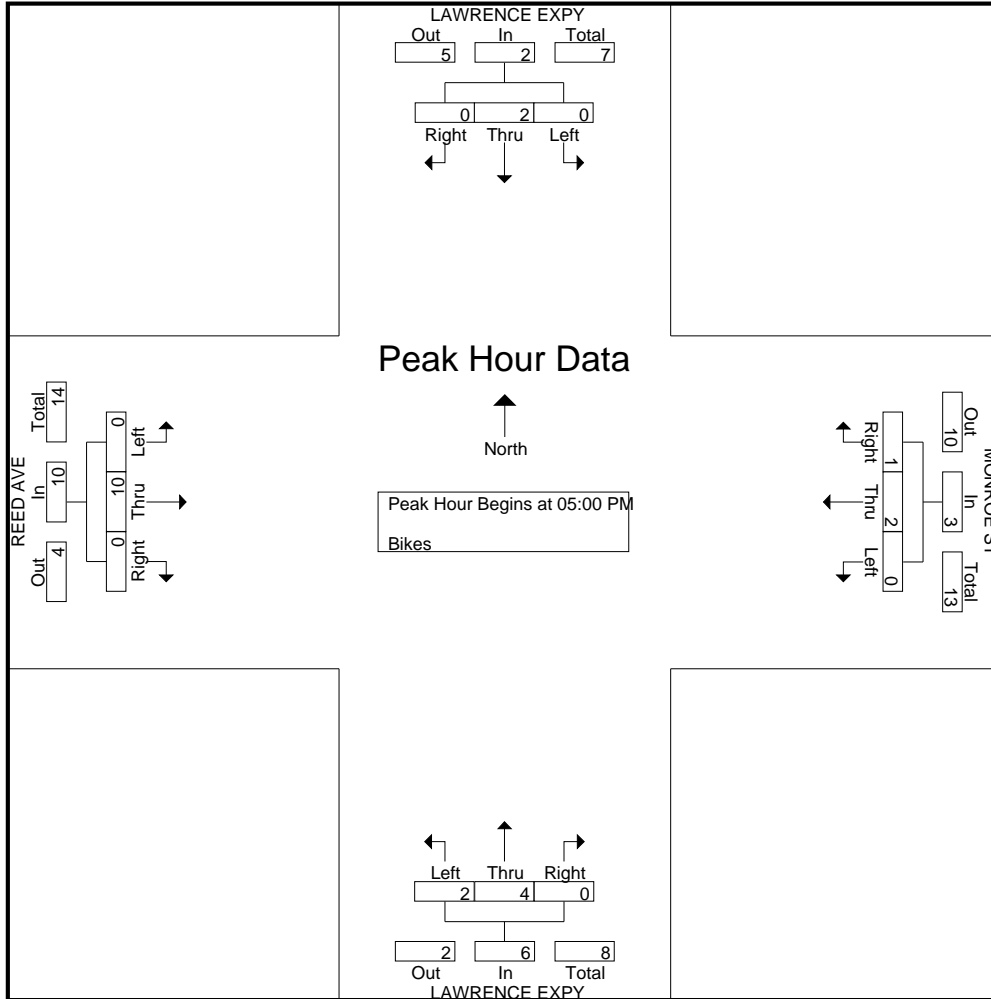

Traffic Data Service

Campbell, CA
 (408) 377-2988
 tdsbay@cs.com

File Name : 28AM FINAL
 Site Code : 00000028
 Start Date : 5/23/2013
 Page No : 1

Groups Printed- Vehicles

Start Time	EL CAMINO REAL Southbound					RAILROAD AVE Westbound					EL CAMINO REAL Northbound					PALM DR Eastbound					Int. Total
	Right	Thru	Left	Peds	App. Total	Right	Thru	Left	Peds	App. Total	Right	Thru	Left	Peds	App. Total	Right	Thru	Left	Peds	App. Total	
07:00 AM	10	47	7	4	68	8	1	10	4	23	11	135	20	5	171	3	1	2	0	6	268
07:15 AM	7	61	11	2	81	5	0	13	2	20	12	211	22	5	250	0	0	1	2	3	354
07:30 AM	13	74	8	8	103	10	3	4	1	18	8	234	25	6	273	4	1	1	3	9	403
07:45 AM	24	76	20	4	124	13	1	13	3	30	12	245	46	16	319	4	0	2	1	7	480
Total	54	258	46	18	376	36	5	40	10	91	43	825	113	32	1013	11	2	6	6	25	1505
08:00 AM	17	89	16	5	127	11	3	7	0	21	11	279	49	6	345	4	1	2	4	11	504
08:15 AM	21	83	17	4	125	13	4	9	6	32	17	254	52	6	329	4	0	2	4	10	496
08:30 AM	27	104	12	12	155	6	1	20	2	29	18	283	50	20	371	5	0	3	2	10	565
08:45 AM	34	108	11	5	158	8	6	10	1	25	5	221	47	11	284	8	1	1	2	12	479
Total	99	384	56	26	565	38	14	46	9	107	51	1037	198	43	1329	21	2	8	12	43	2044
Grand Total	153	642	102	44	941	74	19	86	19	198	94	1862	311	75	2342	32	4	14	18	68	3549
Apprch %	16.3	68.2	10.8	4.7		37.4	9.6	43.4	9.6		4	79.5	13.3	3.2		47.1	5.9	20.6	26.5		
Total %	4.3	18.1	2.9	1.2	26.5	2.1	0.5	2.4	0.5	5.6	2.6	52.5	8.8	2.1	66	0.9	0.1	0.4	0.5	1.9	

Start Time	EL CAMINO REAL Southbound				RAILROAD AVE Westbound				EL CAMINO REAL Northbound				PALM DR Eastbound				Int. Total
	Right	Thru	Left	App. Total	Right	Thru	Left	App. Total	Right	Thru	Left	App. Total	Right	Thru	Left	App. Total	
Peak Hour Analysis From 07:00 AM to 08:45 AM - Peak 1 of 1																	
Peak Hour for Entire Intersection Begins at 08:00 AM																	
08:00 AM	17	89	16	122	11	3	7	21	11	279	49	339	4	1	2	7	489
08:15 AM	21	83	17	121	13	4	9	26	17	254	52	323	4	0	2	6	476
08:30 AM	27	104	12	143	6	1	20	27	18	283	50	351	5	0	3	8	529
08:45 AM	34	108	11	153	8	6	10	24	5	221	47	273	8	1	1	10	460
Total Volume	99	384	56	539	38	14	46	98	51	1037	198	1286	21	2	8	31	1954
% App. Total	18.4	71.2	10.4		38.8	14.3	46.9		4	80.6	15.4		67.7	6.5	25.8		
PHF	.728	.889	.824	.881	.731	.583	.575	.907	.708	.916	.952	.916	.656	.500	.667	.775	.923

Traffic Data Service

Campbell, CA
 (408) 377-2988
 tdsbay@cs.com

File Name : 28AM FINAL
 Site Code : 00000028
 Start Date : 5/23/2013
 Page No : 2

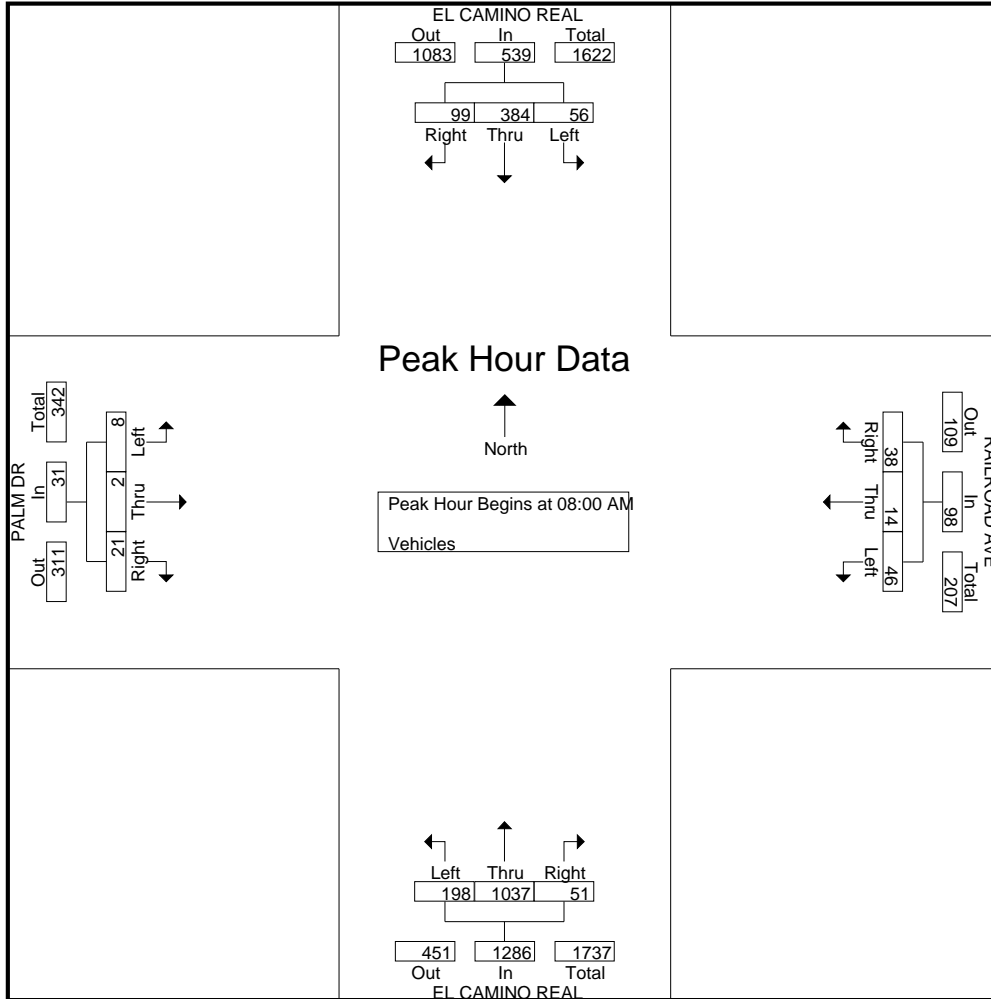

Traffic Data Service

Campbell, CA
 (408) 377-2988
 tdsbay@cs.com

File Name : 28AM FINAL
 Site Code : 00000028
 Start Date : 5/23/2013
 Page No : 1

Groups Printed- Bikes

Start Time	EL CAMINO REAL Southbound					RAILROAD AVE Westbound					EL CAMINO REAL Northbound					PALM DR Eastbound					Int. Total
	Right	Thru	Left	Peds	App. Total	Right	Thru	Left	Peds	App. Total	Right	Thru	Left	Peds	App. Total	Right	Thru	Left	Peds	App. Total	
07:00 AM	0	0	0	0	0	0	0	0	0	0	0	0	0	0	0	0	0	0	0	0	0
07:15 AM	0	1	0	0	1	1	3	0	0	4	0	1	0	0	1	0	0	0	0	0	0
07:30 AM	0	0	0	0	0	0	2	1	0	3	0	1	0	0	1	0	0	0	0	0	0
07:45 AM	0	1	0	0	1	0	0	0	0	0	0	0	0	0	0	0	1	0	0	0	1
Total	0	2	0	0	2	1	5	1	0	7	0	2	0	0	2	0	1	0	0	1	12
08:00 AM	0	0	0	0	0	1	0	0	0	1	0	0	0	0	0	0	0	0	0	0	0
08:15 AM	0	0	0	0	0	0	0	0	0	0	0	0	0	0	0	0	0	0	0	0	0
08:30 AM	0	0	0	0	0	0	0	0	0	0	0	0	0	0	0	1	0	0	0	0	1
08:45 AM	0	0	0	0	0	0	0	0	0	0	0	0	0	0	0	0	0	0	0	0	0
Total	0	0	0	0	0	1	0	0	0	1	0	0	0	0	0	1	0	0	0	1	2
Grand Total	0	2	0	0	2	2	5	1	0	8	0	2	0	0	2	1	1	0	0	2	14
Apprch %	0	100	0	0		25	62.5	12.5	0		0	100	0	0		50	50	0	0		
Total %	0	14.3	0	0	14.3	14.3	35.7	7.1	0	57.1	0	14.3	0	0	14.3	7.1	7.1	0	0	14.3	

Start Time	EL CAMINO REAL Southbound					RAILROAD AVE Westbound					EL CAMINO REAL Northbound					PALM DR Eastbound					Int. Total
	Right	Thru	Left	Peds	App. Total	Right	Thru	Left	Peds	App. Total	Right	Thru	Left	Peds	App. Total	Right	Thru	Left	Peds	App. Total	
07:15 AM	0	1	0	0	1	1	3	0	0	4	0	1	0	0	1	0	0	0	0	0	0
07:30 AM	0	0	0	0	0	0	2	1	0	3	0	1	0	0	1	0	0	0	0	0	0
07:45 AM	0	1	0	0	1	0	0	0	0	0	0	0	0	0	0	0	1	0	0	0	1
08:00 AM	0	0	0	0	0	1	0	0	0	1	0	0	0	0	0	0	0	0	0	0	0
Total Volume	0	2	0	0	2	2	5	1	0	8	0	2	0	0	2	0	1	0	0	1	13
% App. Total	0	100	0	0		25	62.5	12.5	0		0	100	0	0		0	100	0	0		
PHF	.000	.500	.000	.000	.500	.500	.417	.250	.500	.500	.000	.500	.000	.500	.500	.000	.250	.000	.250	.542	

Peak Hour Analysis From 07:00 AM to 08:45 AM - Peak 1 of 1

Peak Hour for Entire Intersection Begins at 07:15 AM

Traffic Data Service

Campbell, CA
(408) 377-2988
tdsbay@cs.com

File Name : 28AM FINAL
Site Code : 00000028
Start Date : 5/23/2013
Page No : 2

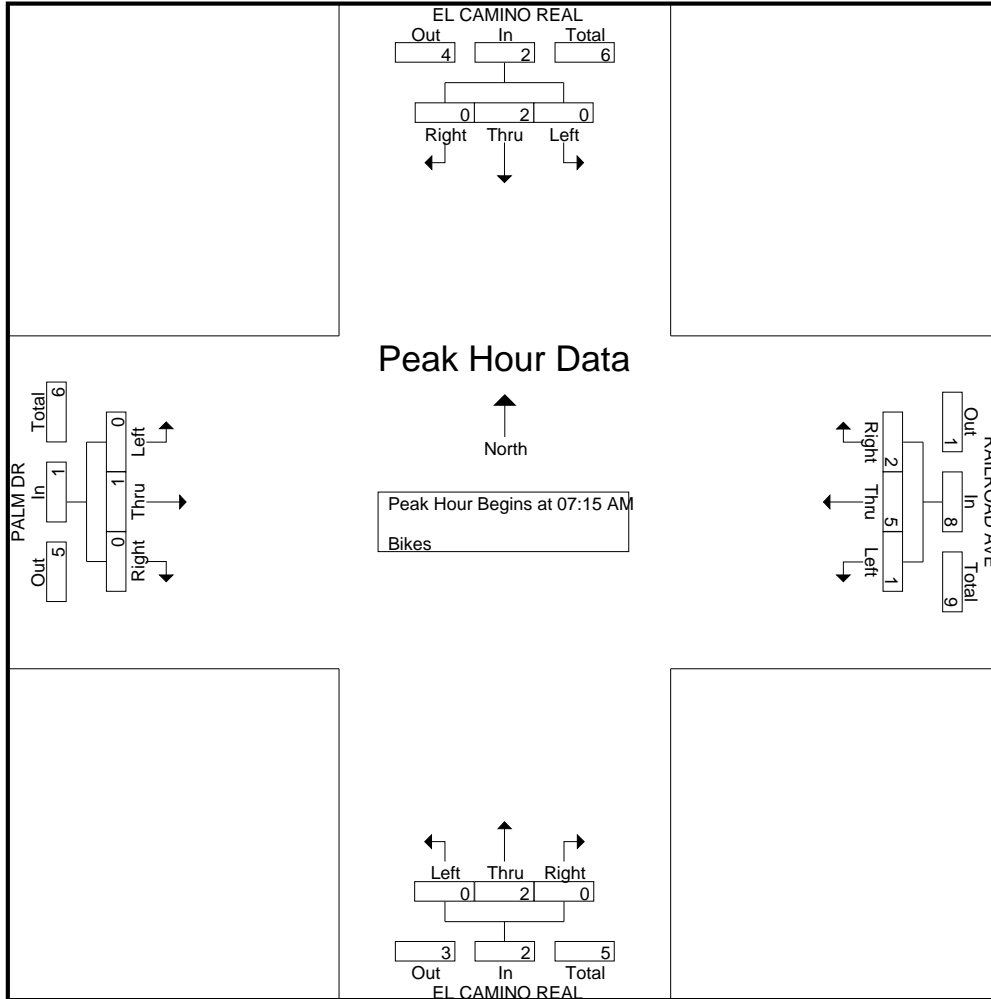

Traffic Data Service

Campbell, CA
 (408) 377-2988
 tdsbay@cs.com

File Name : 28PM FINAL
 Site Code : 00000028
 Start Date : 5/23/2013
 Page No : 1

Groups Printed- Vehicles

Start Time	EL CAMINO REAL Southbound					RAILROAD AVE Westbound					EL CAMINO REAL Northbound					PALM DR Eastbound					Int. Total
	Right	Thru	Left	Peds	App. Total	Right	Thru	Left	Peds	App. Total	Right	Thru	Left	Peds	App. Total	Right	Thru	Left	Peds	App. Total	
04:00 PM	14	201	18	2	235	9	1	11	3	24	3	137	16	9	165	24	1	8	3	36	460
04:15 PM	15	182	17	4	218	8	2	13	5	28	7	118	27	14	166	26	1	8	2	37	449
04:30 PM	32	242	22	21	317	14	1	15	3	33	4	150	22	4	180	30	1	5	2	38	568
04:45 PM	26	221	15	9	271	6	2	13	3	24	6	139	31	7	183	19	3	7	2	31	509
Total	87	846	72	36	1041	37	6	52	14	109	20	544	96	34	694	99	6	28	9	142	1986
05:00 PM	48	270	19	9	346	7	1	14	4	26	0	166	42	12	220	44	1	10	6	61	653
05:15 PM	42	309	20	7	378	3	3	7	6	19	4	154	56	9	223	29	0	18	4	51	671
05:30 PM	41	268	19	5	333	7	2	16	2	27	4	173	41	6	224	28	0	17	6	51	635
05:45 PM	25	274	8	12	319	6	2	28	0	36	10	166	28	10	214	15	1	9	2	27	596
Total	156	1121	66	33	1376	23	8	65	12	108	18	659	167	37	881	116	2	54	18	190	2555
Grand Total	243	1967	138	69	2417	60	14	117	26	217	38	1203	263	71	1575	215	8	82	27	332	4541
Apprch %	10.1	81.4	5.7	2.9		27.6	6.5	53.9	12		2.4	76.4	16.7	4.5		64.8	2.4	24.7	8.1		
Total %	5.4	43.3	3	1.5	53.2	1.3	0.3	2.6	0.6	4.8	0.8	26.5	5.8	1.6	34.7	4.7	0.2	1.8	0.6	7.3	

Start Time	EL CAMINO REAL Southbound				RAILROAD AVE Westbound				EL CAMINO REAL Northbound				PALM DR Eastbound				Int. Total
	Right	Thru	Left	App. Total	Right	Thru	Left	App. Total	Right	Thru	Left	App. Total	Right	Thru	Left	App. Total	
Peak Hour Analysis From 04:00 PM to 05:45 PM - Peak 1 of 1																	
Peak Hour for Entire Intersection Begins at 05:00 PM																	
05:00 PM	48	270	19	337	7	1	14	22	0	166	42	208	44	1	10	55	622
05:15 PM	42	309	20	371	3	3	7	13	4	154	56	214	29	0	18	47	645
05:30 PM	41	268	19	328	7	2	16	25	4	173	41	218	28	0	17	45	616
05:45 PM	25	274	8	307	6	2	28	36	10	166	28	204	15	1	9	25	572
Total Volume	156	1121	66	1343	23	8	65	96	18	659	167	844	116	2	54	172	2455
% App. Total	11.6	83.5	4.9		24	8.3	67.7		2.1	78.1	19.8		67.4	1.2	31.4		
PHF	.813	.907	.825	.905	.821	.667	.580	.667	.450	.952	.746	.968	.659	.500	.750	.782	.952

Traffic Data Service

Campbell, CA
(408) 377-2988
tdsbay@cs.com

File Name : 28PM FINAL
Site Code : 00000028
Start Date : 5/23/2013
Page No : 2

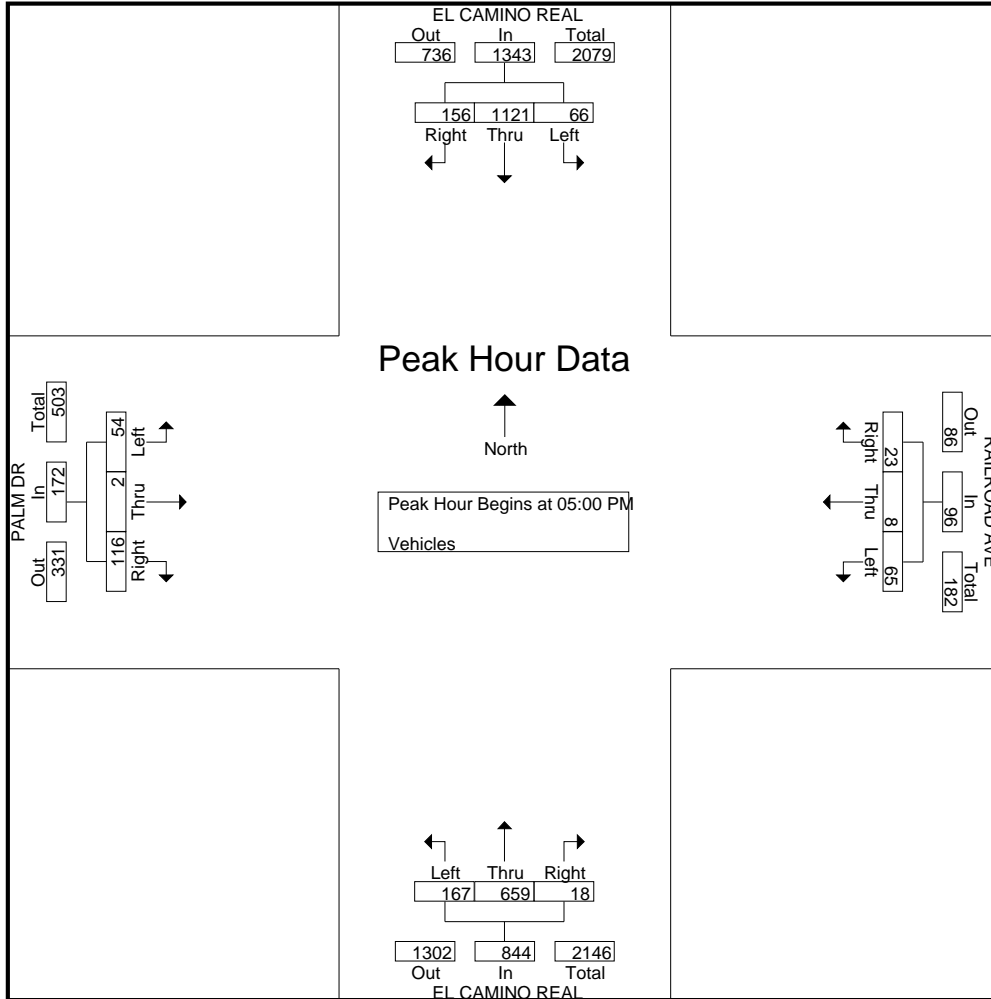

Traffic Data Service

Campbell, CA
 (408) 377-2988
 tdsbay@cs.com

File Name : 28PM FINAL
 Site Code : 00000028
 Start Date : 5/23/2013
 Page No : 1

Groups Printed- Bikes

Start Time	EL CAMINO REAL Southbound					RAILROAD AVE Westbound					EL CAMINO REAL Northbound					PALM DR Eastbound					Int. Total
	Right	Thru	Left	Peds	App. Total	Right	Thru	Left	Peds	App. Total	Right	Thru	Left	Peds	App. Total	Right	Thru	Left	Peds	App. Total	
04:00 PM	1	1	0	0	2	0	0	0	0	0	0	0	0	0	0	0	0	0	0	0	2
04:15 PM	0	0	0	0	0	0	0	0	0	0	0	0	0	0	0	0	3	0	0	0	3
04:30 PM	0	2	0	0	2	0	0	0	0	0	0	0	0	0	0	0	0	0	0	0	2
04:45 PM	0	1	0	0	1	0	5	0	0	5	0	0	0	0	0	0	0	0	0	0	6
Total	1	4	0	0	5	0	5	0	0	5	0	0	0	0	0	0	3	0	0	3	13
05:00 PM	0	1	0	0	1	0	0	0	0	0	0	0	0	0	0	0	0	0	0	0	1
05:15 PM	0	1	0	0	1	0	0	1	0	1	0	2	0	0	2	0	0	0	0	0	4
05:30 PM	0	2	0	0	2	0	0	0	0	0	0	0	0	0	0	0	0	0	0	0	2
05:45 PM	0	0	0	0	0	0	4	1	0	5	0	0	0	0	0	0	0	0	0	0	5
Total	0	4	0	0	4	0	4	2	0	6	0	2	0	0	2	0	0	0	0	0	12
Grand Total	1	8	0	0	9	0	9	2	0	11	0	2	0	0	2	0	3	0	0	3	25
Apprch %	11.1	88.9	0	0		0	81.8	18.2	0		0	100	0	0		0	100	0	0		
Total %	4	32	0	0	36	0	36	8	0	44	0	8	0	0	8	0	12	0	0	12	

Start Time	EL CAMINO REAL Southbound					RAILROAD AVE Westbound					EL CAMINO REAL Northbound					PALM DR Eastbound					Int. Total
	Right	Thru	Left	Peds	App. Total	Right	Thru	Left	Peds	App. Total	Right	Thru	Left	Peds	App. Total	Right	Thru	Left	Peds	App. Total	
04:00 PM	1	1	0	0	2	0	0	0	0	0	0	0	0	0	0	0	0	0	0	0	2
04:15 PM	0	0	0	0	0	0	0	0	0	0	0	0	0	0	0	0	3	0	0	0	3
04:30 PM	0	2	0	0	2	0	0	0	0	0	0	0	0	0	0	0	0	0	0	0	2
04:45 PM	0	1	0	0	1	0	5	0	0	5	0	0	0	0	0	0	0	0	0	0	6
Total Volume	1	4	0	0	5	0	5	0	0	5	0	0	0	0	0	0	3	0	0	3	13
% App. Total	20	80	0	0		0	100	0	0		0	0	0	0		0	100	0	0		
PHF	.250	.500	.000	.000	.625	.000	.250	.000	.000	.250	.000	.000	.000	.000	.000	.000	.250	.000	.000	.250	.542

Peak Hour Analysis From 04:00 PM to 05:45 PM - Peak 1 of 1

Peak Hour for Entire Intersection Begins at 04:00 PM

Traffic Data Service

Campbell, CA
(408) 377-2988
tdsbay@cs.com

File Name : 28PM FINAL
Site Code : 00000028
Start Date : 5/23/2013
Page No : 2

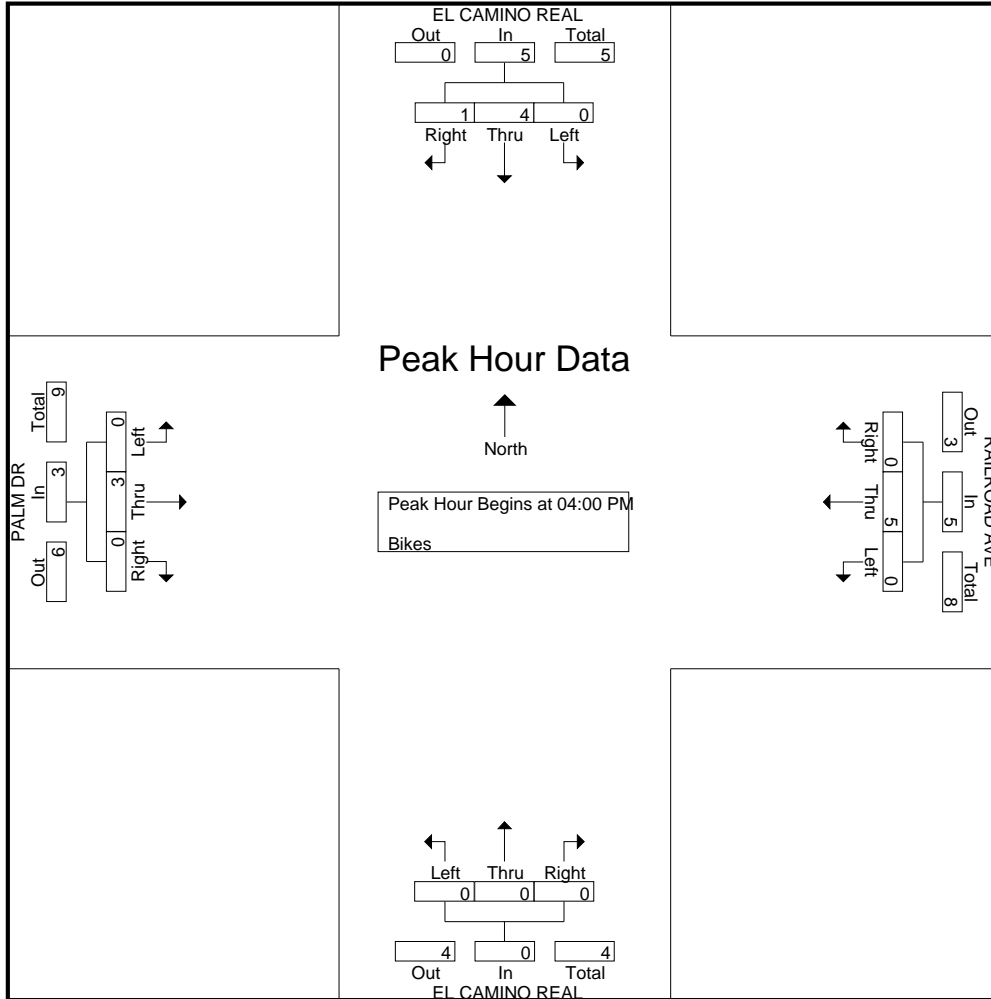

Traffic Data Service

Campbell, CA
 (408) 377-2988
 tdsbay@cs.com

File Name : 100AM FINAL
 Site Code : 00000100
 Start Date : 6/4/2013
 Page No : 1

Groups Printed- Vehicles

Start Time	DRIVEWAY Southbound					W. SANTA CLARA ST Westbound					CAHILL ST Northbound					W. SANTA CLARA ST Eastbound					Int. Total
	Right	Thru	Left	Peds	App. Total	Right	Thru	Left	Peds	App. Total	Right	Thru	Left	Peds	App. Total	Right	Thru	Left	Peds	App. Total	
07:00 AM	0	0	0	6	6	1	114	24	15	154	10	0	12	5	27	9	35	0	0	44	231
07:15 AM	0	0	0	6	6	0	168	20	22	210	7	0	17	3	27	20	62	0	0	82	325
07:30 AM	0	0	0	1	1	2	192	45	17	256	24	0	21	2	47	15	93	0	0	108	412
07:45 AM	0	0	0	6	6	1	255	34	20	310	24	0	22	7	53	20	120	0	0	140	509
Total	0	0	0	19	19	4	729	123	74	930	65	0	72	17	154	64	310	0	0	374	1477
08:00 AM	0	0	0	4	4	1	227	17	15	260	9	0	8	7	24	2	103	0	0	105	393
08:15 AM	0	0	0	4	4	1	212	15	16	244	6	0	12	9	27	10	126	0	1	137	412
08:30 AM	0	0	1	11	12	1	177	11	14	203	9	0	12	12	33	10	94	0	1	105	353
08:45 AM	0	0	0	4	4	2	163	13	17	195	4	0	3	9	16	6	102	0	0	108	323
Total	0	0	1	23	24	5	779	56	62	902	28	0	35	37	100	28	425	0	2	455	1481
Grand Total	0	0	1	42	43	9	1508	179	136	1832	93	0	107	54	254	92	735	0	2	829	2958
Apprch %	0	0	2.3	97.7		0.5	82.3	9.8	7.4		36.6	0	42.1	21.3		11.1	88.7	0	0.2		
Total %	0	0	0	1.4	1.5	0.3	51	6.1	4.6	61.9	3.1	0	3.6	1.8	8.6	3.1	24.8	0	0.1	28	

Start Time	DRIVEWAY Southbound					W. SANTA CLARA ST Westbound					CAHILL ST Northbound					W. SANTA CLARA ST Eastbound					Int. Total
	Right	Thru	Left	Peds	App. Total	Right	Thru	Left	Peds	App. Total	Right	Thru	Left	Peds	App. Total	Right	Thru	Left	Peds	App. Total	
07:30 AM	0	0	0	0	0	2	192	45	239	24	0	21	45	15	93	0	108	392			
07:45 AM	0	0	0	0	0	1	255	34	290	24	0	22	46	20	120	0	140	476			
08:00 AM	0	0	0	0	0	1	227	17	245	9	0	8	17	2	103	0	105	367			
08:15 AM	0	0	0	0	0	1	212	15	228	6	0	12	18	10	126	0	136	382			
Total Volume	0	0	0	0	0	5	886	111	1002	63	0	63	126	47	442	0	489	1617			
% App. Total	0	0	0	0		0.5	88.4	11.1		50	0	50		9.6	90.4	0					
PHF	.000	.000	.000	.000	.000	.625	.869	.617	.864	.656	.000	.716	.685	.588	.877	.000	.873	.849			

Peak Hour Analysis From 07:00 AM to 08:45 AM - Peak 1 of 1

Peak Hour for Entire Intersection Begins at 07:30 AM

Traffic Data Service

Campbell, CA
 (408) 377-2988
 tdsbay@cs.com

File Name : 100AM FINAL
 Site Code : 00000100
 Start Date : 6/4/2013
 Page No : 2

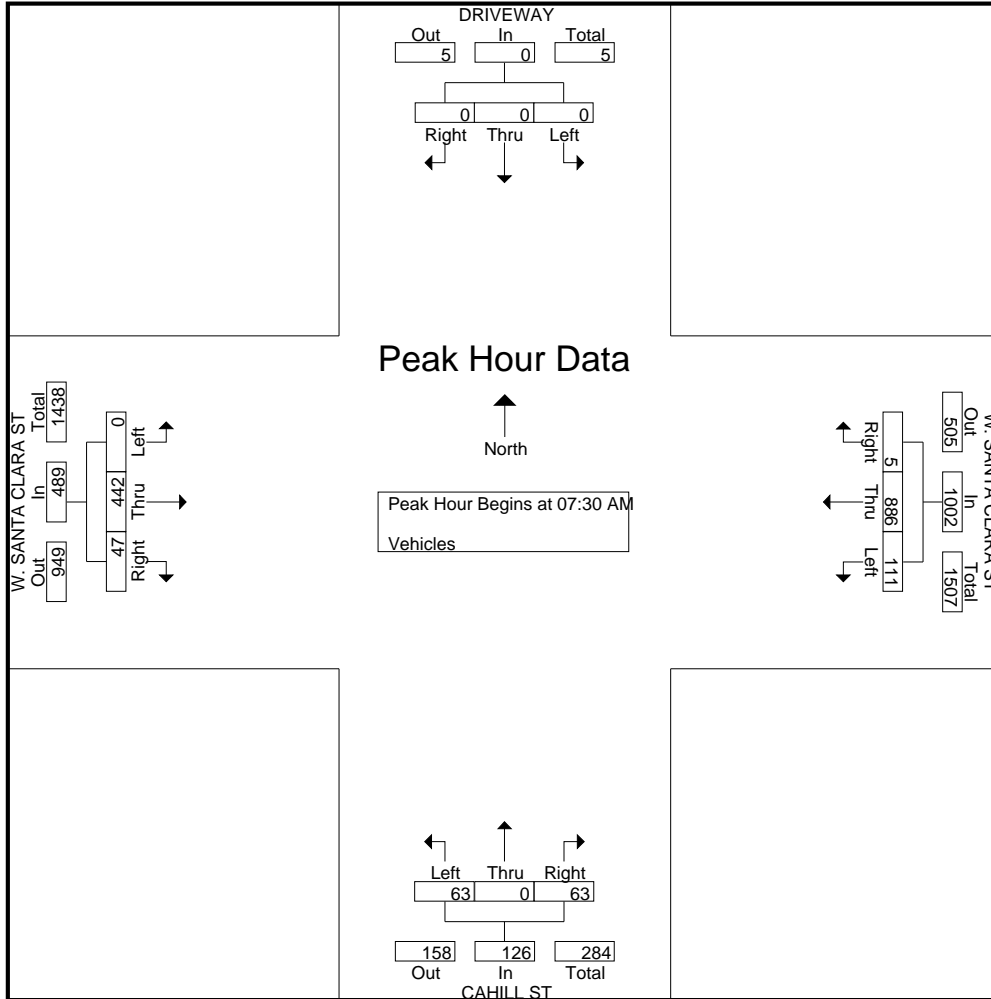

Traffic Data Service

Campbell, CA
 (408) 377-2988
 tdsbay@cs.com

File Name : 100AM FINAL
 Site Code : 00000100
 Start Date : 6/4/2013
 Page No : 1

Groups Printed- Bikes

Start Time	DRIVEWAY Southbound					W. SANTA CLARA ST Westbound					CAHILL ST Northbound					W. SANTA CLARA ST Eastbound					Int. Total
	Right	Thru	Left	Peds	App. Total	Right	Thru	Left	Peds	App. Total	Right	Thru	Left	Peds	App. Total	Right	Thru	Left	Peds	App. Total	
07:00 AM	0	0	0	0	0	0	0	0	0	0	1	0	1	0	2	0	2	0	0	2	4
07:15 AM	0	0	0	0	0	0	1	1	0	2	1	0	0	0	1	0	2	1	0	3	6
07:30 AM	0	0	0	0	0	0	0	6	0	6	1	0	1	0	2	0	2	0	0	2	10
07:45 AM	0	0	0	0	0	0	0	0	0	0	0	0	1	0	1	2	1	0	0	3	4
Total	0	0	0	0	0	0	1	7	0	8	3	0	3	0	6	2	7	1	0	10	24
08:00 AM	0	0	0	0	0	0	0	0	0	0	1	1	0	0	2	1	2	0	0	3	5
08:15 AM	0	0	0	0	0	0	1	0	0	1	1	0	0	0	1	0	2	0	0	2	4
08:30 AM	0	0	0	0	0	0	1	0	0	1	1	0	0	0	1	0	0	0	0	0	2
08:45 AM	1	0	0	0	1	0	0	0	0	0	0	0	0	0	0	1	1	0	0	2	3
Total	1	0	0	0	1	0	2	0	0	2	3	1	0	0	4	2	5	0	0	7	14
Grand Total	1	0	0	0	1	0	3	7	0	10	6	1	3	0	10	4	12	1	0	17	38
Apprch %	100	0	0	0		0	30	70	0		60	10	30	0		23.5	70.6	5.9	0		
Total %	2.6	0	0	0	2.6	0	7.9	18.4	0	26.3	15.8	2.6	7.9	0	26.3	10.5	31.6	2.6	0	44.7	

Start Time	DRIVEWAY Southbound					W. SANTA CLARA ST Westbound					CAHILL ST Northbound					W. SANTA CLARA ST Eastbound					Int. Total
	Right	Thru	Left	Peds	App. Total	Right	Thru	Left	Peds	App. Total	Right	Thru	Left	Peds	App. Total	Right	Thru	Left	Peds	App. Total	
07:15 AM	0	0	0	0	0	0	1	1	0	2	1	0	0	0	1	0	2	1	0	3	6
07:30 AM	0	0	0	0	0	0	0	6	0	6	1	0	1	0	2	0	2	0	0	2	10
07:45 AM	0	0	0	0	0	0	0	0	0	0	0	0	1	0	1	2	1	0	0	3	4
08:00 AM	0	0	0	0	0	0	0	0	0	0	1	1	0	0	2	1	2	0	0	3	5
Total Volume	0	0	0	0	0	0	1	7	0	8	3	1	2	0	6	3	7	1	0	11	25
% App. Total	0	0	0	0		0	12.5	87.5	0		50	16.7	33.3	0		27.3	63.6	9.1	0		
PHF	.000	.000	.000	.000	.000	.000	.250	.292	.333	.333	.750	.250	.500	.750	.750	.375	.875	.250	.917	.917	.625

Peak Hour Analysis From 07:00 AM to 08:45 AM - Peak 1 of 1

Peak Hour for Entire Intersection Begins at 07:15 AM

Traffic Data Service

Campbell, CA
(408) 377-2988
tdsbay@cs.com

File Name : 100AM FINAL
Site Code : 00000100
Start Date : 6/4/2013
Page No : 2

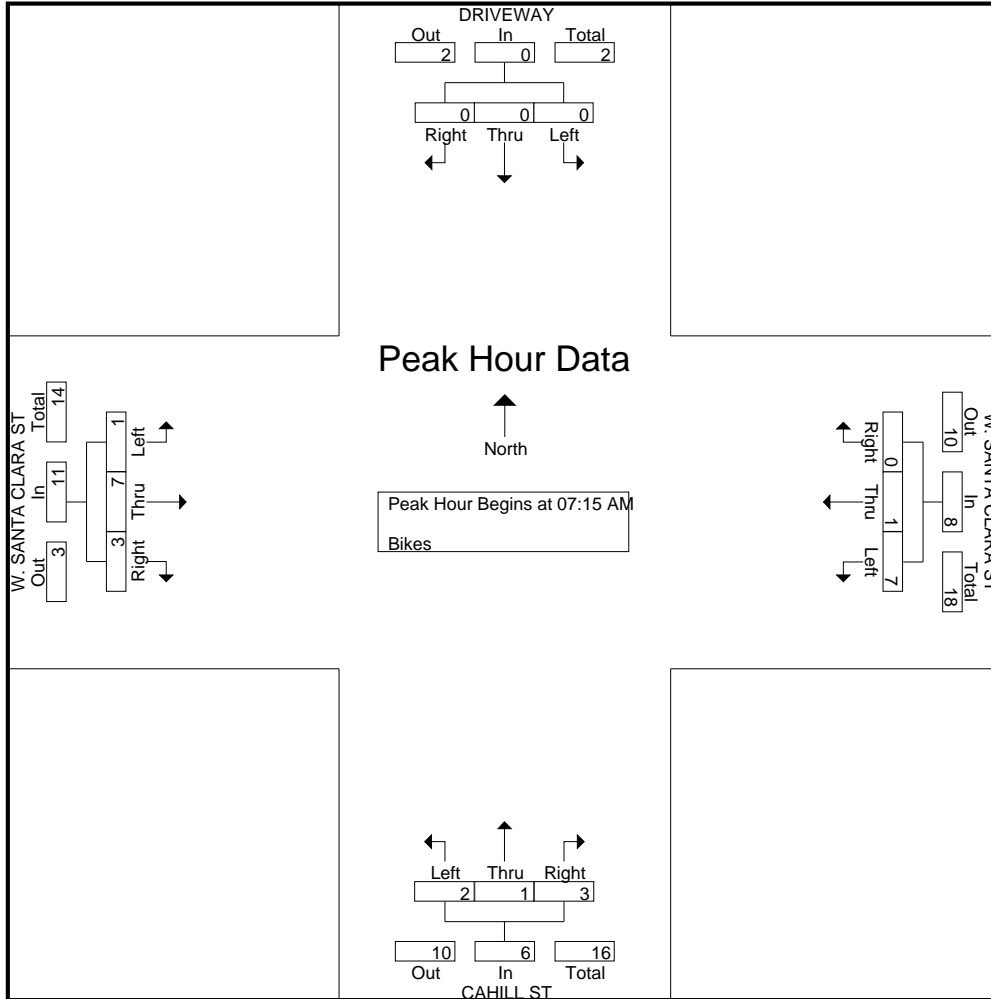

Traffic Data Service

Campbell, CA
 (408) 377-2988
 tdsbay@cs.com

File Name : 100PM FINAL
 Site Code : 00000100
 Start Date : 6/4/2013
 Page No : 1

Groups Printed- Vehicles

Start Time	DRIVEWAY Southbound					W. SANTA CLARA ST Westbound					CAHILL ST Northbound					W. SANTA CLARA ST Eastbound					Int. Total
	Right	Thru	Left	Peds	App. Total	Right	Thru	Left	Peds	App. Total	Right	Thru	Left	Peds	App. Total	Right	Thru	Left	Peds	App. Total	
04:00 PM	0	0	0	5	5	2	133	12	9	156	8	0	15	12	35	13	148	0	0	161	357
04:15 PM	0	0	0	7	7	0	135	11	9	155	4	0	5	10	19	9	194	0	0	203	384
04:30 PM	1	0	2	3	6	0	157	15	6	178	6	0	6	10	22	10	184	0	0	194	400
04:45 PM	0	0	0	7	7	0	153	15	4	172	12	0	4	7	23	10	193	0	0	203	405
Total	1	0	2	22	25	2	578	53	28	661	30	0	30	39	99	42	719	0	0	761	1546
05:00 PM	1	1	0	10	12	0	144	34	0	178	25	0	36	0	61	15	189	0	0	204	455
05:15 PM	0	0	0	8	8	0	155	30	0	185	16	0	13	2	31	20	211	0	0	231	455
05:30 PM	1	0	0	4	5	0	130	22	7	159	20	0	33	4	57	29	201	0	0	230	451
05:45 PM	0	0	0	10	10	0	187	12	0	199	15	0	12	0	27	12	192	0	0	204	440
Total	2	1	0	32	35	0	616	98	7	721	76	0	94	6	176	76	793	0	0	869	1801
Grand Total	3	1	2	54	60	2	1194	151	35	1382	106	0	124	45	275	118	1512	0	0	1630	3347
Apprch %	5	1.7	3.3	90		0.1	86.4	10.9	2.5		38.5	0	45.1	16.4		7.2	92.8	0	0		
Total %	0.1	0	0.1	1.6	1.8	0.1	35.7	4.5	1	41.3	3.2	0	3.7	1.3	8.2	3.5	45.2	0	0	48.7	

Start Time	DRIVEWAY Southbound				W. SANTA CLARA ST Westbound				CAHILL ST Northbound				W. SANTA CLARA ST Eastbound				Int. Total
	Right	Thru	Left	App. Total	Right	Thru	Left	App. Total	Right	Thru	Left	App. Total	Right	Thru	Left	App. Total	
Peak Hour Analysis From 04:00 PM to 05:45 PM - Peak 1 of 1																	
Peak Hour for Entire Intersection Begins at 05:00 PM																	
05:00 PM	1	1	0	2	0	144	34	178	25	0	36	61	15	189	0	204	445
05:15 PM	0	0	0	0	0	155	30	185	16	0	13	29	20	211	0	231	445
05:30 PM	1	0	0	1	0	130	22	152	20	0	33	53	29	201	0	230	436
05:45 PM	0	0	0	0	0	187	12	199	15	0	12	27	12	192	0	204	430
Total Volume	2	1	0	3	0	616	98	714	76	0	94	170	76	793	0	869	1756
% App. Total	66.7	33.3	0		0	86.3	13.7		44.7	0	55.3		8.7	91.3	0		
PHF	.500	.250	.000	.375	.000	.824	.721	.897	.760	.000	.653	.697	.655	.940	.000	.940	.987

Traffic Data Service

Campbell, CA
 (408) 377-2988
 tdsbay@cs.com

File Name : 100PM FINAL
 Site Code : 00000100
 Start Date : 6/4/2013
 Page No : 2

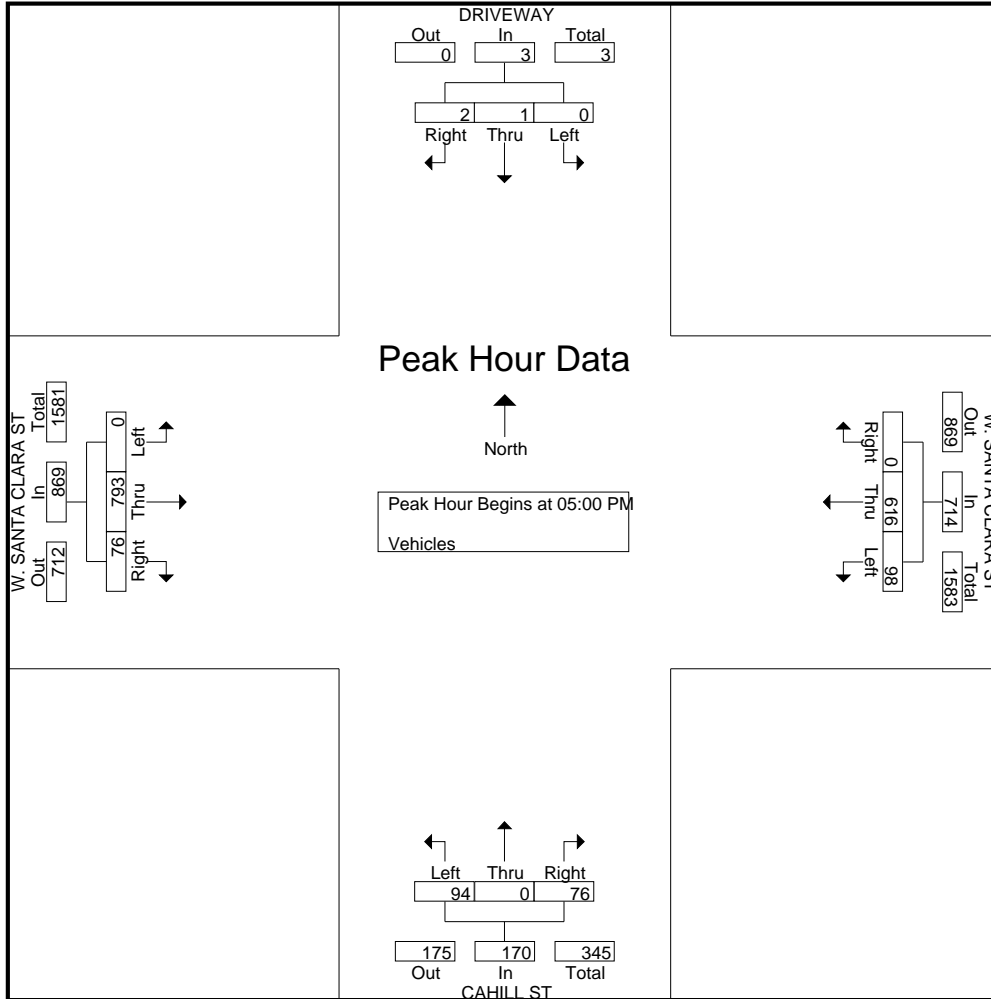

Traffic Data Service

Campbell, CA
 (408) 377-2988
 tdsbay@cs.com

File Name : 100PM FINAL
 Site Code : 00000100
 Start Date : 6/4/2013
 Page No : 1

Groups Printed- Bikes

Start Time	DRIVEWAY Southbound					W. SANTA CLARA ST Westbound					CAHILL ST Northbound					W. SANTA CLARA ST Eastbound					Int. Total
	Right	Thru	Left	Peds	App. Total	Right	Thru	Left	Peds	App. Total	Right	Thru	Left	Peds	App. Total	Right	Thru	Left	Peds	App. Total	
04:00 PM	0	0	0	0	0	0	0	0	0	0	0	0	0	0	0	3	0	0	0	3	3
04:15 PM	0	0	0	0	0	0	1	2	0	3	0	0	0	0	0	1	2	0	0	3	6
04:30 PM	0	0	0	0	0	0	2	1	0	3	0	0	1	0	1	0	0	0	0	0	4
04:45 PM	0	0	0	0	0	0	0	2	0	2	0	0	0	0	0	0	1	0	0	1	3
Total	0	0	0	0	0	0	3	5	0	8	0	0	1	0	1	4	3	0	0	7	16
05:00 PM	0	0	0	0	0	0	2	1	0	3	0	0	3	0	3	0	1	0	0	1	7
05:15 PM	0	1	0	0	1	0	0	1	0	1	0	0	0	0	0	0	1	0	0	1	3
05:30 PM	0	0	0	0	0	0	1	2	0	3	2	0	1	0	3	1	2	0	0	3	9
05:45 PM	0	0	0	0	0	0	3	0	0	3	0	0	0	0	0	0	0	0	0	0	3
Total	0	1	0	0	1	0	6	4	0	10	2	0	4	0	6	1	4	0	0	5	22
Grand Total	0	1	0	0	1	0	9	9	0	18	2	0	5	0	7	5	7	0	0	12	38
Apprch %	0	100	0	0		0	50	50	0		28.6	0	71.4	0		41.7	58.3	0	0		
Total %	0	2.6	0	0	2.6	0	23.7	23.7	0	47.4	5.3	0	13.2	0	18.4	13.2	18.4	0	0	31.6	

Start Time	DRIVEWAY Southbound					W. SANTA CLARA ST Westbound					CAHILL ST Northbound					W. SANTA CLARA ST Eastbound					Int. Total
	Right	Thru	Left	Peds	App. Total	Right	Thru	Left	Peds	App. Total	Right	Thru	Left	Peds	App. Total	Right	Thru	Left	Peds	App. Total	
04:45 PM	0	0	0	0	0	0	0	2	2	0	0	0	0	0	0	1	0	0	1	3	
05:00 PM	0	0	0	0	0	0	2	1	3	0	0	3	3	0	1	0	0	1	7		
05:15 PM	0	1	0	0	1	0	0	1	1	0	0	0	0	0	0	1	0	0	1	3	
05:30 PM	0	0	0	0	0	0	1	2	3	2	0	1	3	1	2	0	0	3	9		
Total Volume	0	1	0	0	1	0	3	6	9	2	0	4	6	1	5	0	0	6	22		
% App. Total	0	100	0	0		0	33.3	66.7		33.3	0	66.7		16.7	83.3	0	0				
PHF	.000	.250	.000	.000	.250	.000	.375	.750	.750	.250	.000	.333	.500	.250	.625	.000	.000	.500	.611		

Peak Hour Analysis From 04:00 PM to 05:45 PM - Peak 1 of 1

Peak Hour for Entire Intersection Begins at 04:45 PM

Traffic Data Service

Campbell, CA
(408) 377-2988
tdsbay@cs.com

File Name : 100PM FINAL
Site Code : 00000100
Start Date : 6/4/2013
Page No : 2

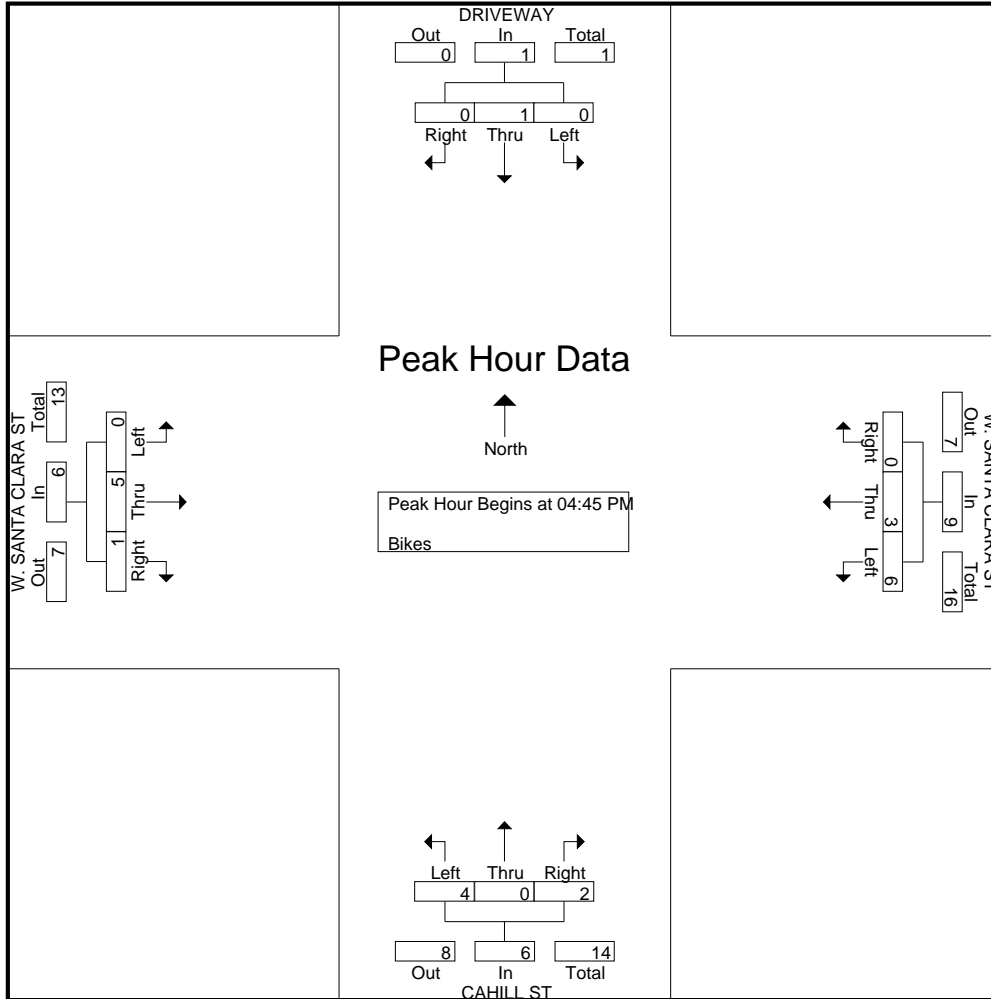

Traffic Data Service

Campbell, CA
 (408) 377-2988
 tdsbay@cs.com

File Name : 101AM FINAL
 Site Code : 00000101
 Start Date : 6/4/2013
 Page No : 1

Groups Printed- Vehicles

Start Time	S. MONTGOMERY ST Southbound					W. SAN FERNANDO ST Westbound					S. MONTGOMERY ST Northbound					W. SAN FERNANDO ST Eastbound					Int. Total
	Right	Thru	Left	Peds	App. Total	Right	Thru	Left	Peds	App. Total	Right	Thru	Left	Peds	App. Total	Right	Thru	Left	Peds	App. Total	
07:00 AM	1	30	3	1	35	0	29	12	1	42	0	0	0	0	0	11	10	0	3	24	101
07:15 AM	0	21	5	3	29	0	36	18	1	55	0	0	0	1	1	10	12	0	0	22	107
07:30 AM	1	48	4	8	61	0	39	33	2	74	0	0	0	1	1	21	12	0	2	35	171
07:45 AM	3	57	8	3	71	0	40	15	0	55	0	0	0	4	4	29	11	0	4	44	174
Total	5	156	20	15	196	0	144	78	4	226	0	0	0	6	6	71	45	0	9	125	553
08:00 AM	1	54	4	4	63	0	20	9	2	31	0	0	0	2	2	16	11	0	1	28	124
08:15 AM	2	44	7	1	54	0	23	15	1	39	0	0	0	3	3	18	9	0	1	28	124
08:30 AM	1	42	2	3	48	0	24	11	1	36	0	0	0	4	4	14	7	0	3	24	112
08:45 AM	1	34	4	2	41	0	14	17	1	32	0	0	0	4	4	16	7	0	2	25	102
Total	5	174	17	10	206	0	81	52	5	138	0	0	0	13	13	64	34	0	7	105	462
Grand Total	10	330	37	25	402	0	225	130	9	364	0	0	0	19	19	135	79	0	16	230	1015
Apprch %	2.5	82.1	9.2	6.2		0	61.8	35.7	2.5		0	0	0	100		58.7	34.3	0	7		
Total %	1	32.5	3.6	2.5	39.6	0	22.2	12.8	0.9	35.9	0	0	0	1.9	1.9	13.3	7.8	0	1.6	22.7	

Start Time	S. MONTGOMERY ST Southbound				W. SAN FERNANDO ST Westbound				S. MONTGOMERY ST Northbound				W. SAN FERNANDO ST Eastbound				Int. Total
	Right	Thru	Left	App. Total	Right	Thru	Left	App. Total	Right	Thru	Left	App. Total	Right	Thru	Left	App. Total	
Peak Hour Analysis From 07:00 AM to 08:45 AM - Peak 1 of 1																	
Peak Hour for Entire Intersection Begins at 07:30 AM																	
07:30 AM	1	48	4	53	0	39	33	72	0	0	0	0	21	12	0	33	158
07:45 AM	3	57	8	68	0	40	15	55	0	0	0	0	29	11	0	40	163
08:00 AM	1	54	4	59	0	20	9	29	0	0	0	0	16	11	0	27	115
08:15 AM	2	44	7	53	0	23	15	38	0	0	0	0	18	9	0	27	118
Total Volume	7	203	23	233	0	122	72	194	0	0	0	0	84	43	0	127	554
% App. Total	3	87.1	9.9		0	62.9	37.1		0	0	0		66.1	33.9	0		
PHF	.583	.890	.719	.857	.000	.763	.545	.674	.000	.000	.000	.000	.724	.896	.000	.794	.850

Traffic Data Service

Campbell, CA

(408) 377-2988

tdsbay@cs.com

File Name : 101AM FINAL

Site Code : 00000101

Start Date : 6/4/2013

Page No : 2

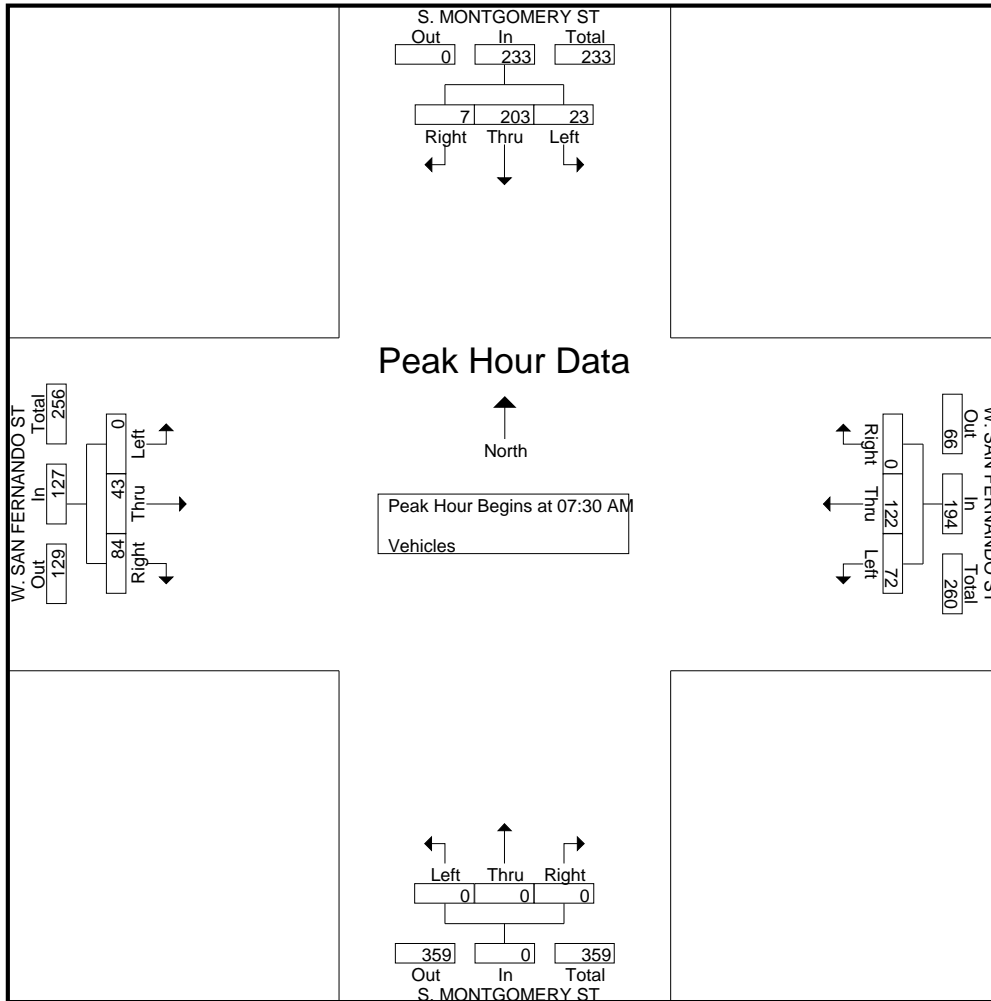

Traffic Data Service

Campbell, CA
(408) 377-2988
tdsbay@cs.com

File Name : 101AM FINAL
Site Code : 00000101
Start Date : 6/4/2013
Page No : 1

Groups Printed- Bikes

Start Time	S. MONTGOMERY ST Southbound					W. SAN FERNANDO ST Westbound					S. MONTGOMERY ST Northbound					W. SAN FERNANDO ST Eastbound					Int. Total
	Right	Thru	Left	Peds	App. Total	Right	Thru	Left	Peds	App. Total	Right	Thru	Left	Peds	App. Total	Right	Thru	Left	Peds	App. Total	
07:00 AM	0	0	0	0	0	0	3	1	0	4	0	0	0	0	0	1	1	0	0	2	6
07:15 AM	0	0	0	0	0	0	4	1	0	5	0	0	0	0	0	0	1	0	0	1	6
07:30 AM	0	0	0	0	0	0	8	0	0	8	0	0	0	0	0	0	0	0	0	0	8
07:45 AM	0	0	0	0	0	0	1	0	0	1	0	0	0	0	0	0	0	0	0	0	1
Total	0	0	0	0	0	0	16	2	0	18	0	0	0	0	0	1	2	0	0	3	21
08:00 AM	0	0	1	0	1	0	3	0	0	3	0	0	0	0	0	1	3	0	0	4	8
08:15 AM	0	0	1	0	1	0	2	0	0	2	0	0	0	0	0	0	0	0	0	0	3
08:30 AM	0	0	0	0	0	0	1	0	0	1	0	0	0	0	0	2	7	0	0	9	10
08:45 AM	0	1	1	0	2	0	2	0	0	2	0	0	0	0	0	4	4	0	0	8	12
Total	0	1	3	0	4	0	8	0	0	8	0	0	0	0	0	7	14	0	0	21	33
Grand Total	0	1	3	0	4	0	24	2	0	26	0	0	0	0	0	8	16	0	0	24	54
Apprch %	0	25	75	0		0	92.3	7.7	0		0	0	0	0		33.3	66.7	0	0		
Total %	0	1.9	5.6	0	7.4	0	44.4	3.7	0	48.1	0	0	0	0	0	14.8	29.6	0	0	44.4	

Start Time	S. MONTGOMERY ST Southbound				W. SAN FERNANDO ST Westbound				S. MONTGOMERY ST Northbound				W. SAN FERNANDO ST Eastbound				Int. Total
	Right	Thru	Left	App. Total	Right	Thru	Left	App. Total	Right	Thru	Left	App. Total	Right	Thru	Left	App. Total	
Peak Hour Analysis From 07:00 AM to 08:45 AM - Peak 1 of 1																	
Peak Hour for Entire Intersection Begins at 08:00 AM																	
08:00 AM	0	0	1	1	0	3	0	3	0	0	0	0	1	3	0	4	8
08:15 AM	0	0	1	1	0	2	0	2	0	0	0	0	0	0	0	0	3
08:30 AM	0	0	0	0	0	1	0	1	0	0	0	0	2	7	0	9	10
08:45 AM	0	1	1	2	0	2	0	2	0	0	0	0	4	4	0	8	12
Total Volume	0	1	3	4	0	8	0	8	0	0	0	0	7	14	0	21	33
% App. Total	0	25	75		0	100	0		0	0	0		33.3	66.7	0		
PHF	.000	.250	.750	.500	.000	.667	.000	.667	.000	.000	.000	.000	.438	.500	.000	.583	.688

Traffic Data Service

Campbell, CA
(408) 377-2988
tdsbay@cs.com

File Name : 101AM FINAL
Site Code : 00000101
Start Date : 6/4/2013
Page No : 2

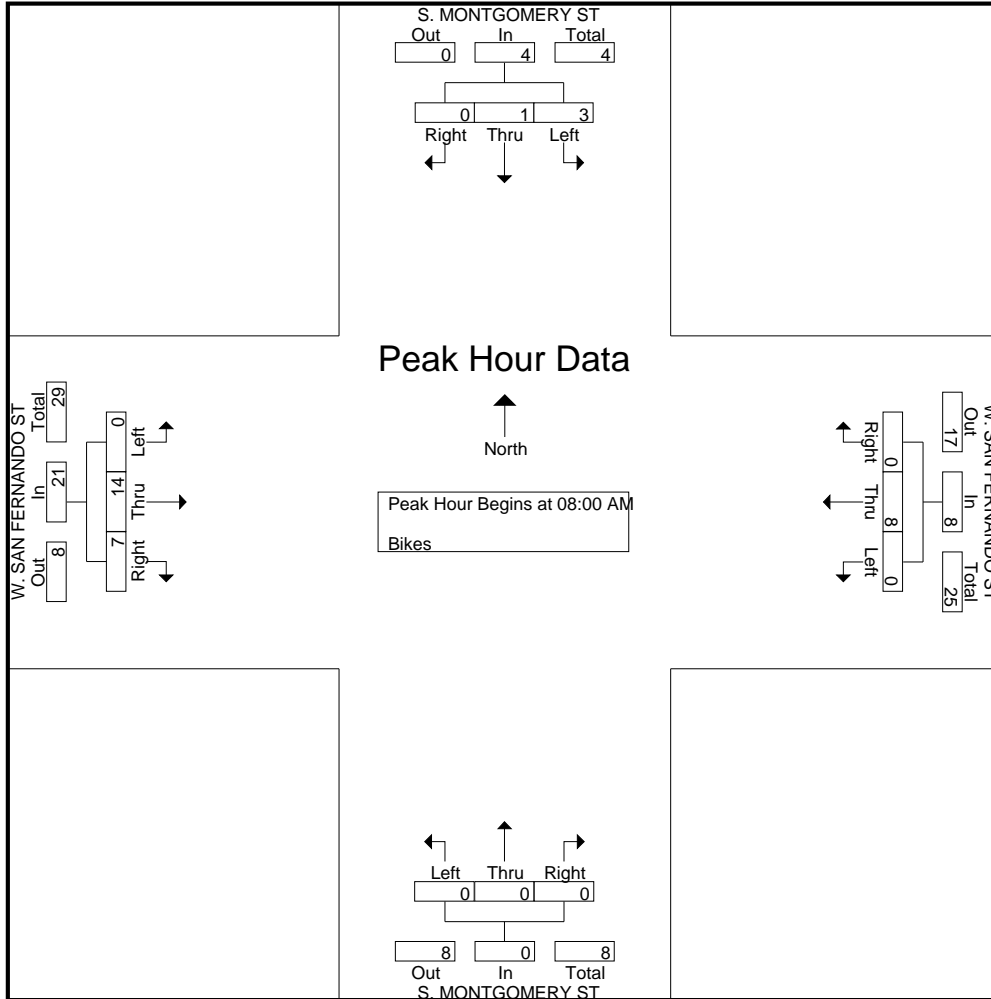

Traffic Data Service

Campbell, CA
 (408) 377-2988
 tdsbay@cs.com

File Name : 101PM FINAL
 Site Code : 00000101
 Start Date : 6/4/2013
 Page No : 1

Groups Printed- Vehicles

Start Time	S. MONTGOMERY ST Southbound					W. SAN FERNANDO ST Westbound					S. MONTGOMERY ST Northbound					W. SAN FERNANDO ST Eastbound					Int. Total
	Right	Thru	Left	Peds	App. Total	Right	Thru	Left	Peds	App. Total	Right	Thru	Left	Peds	App. Total	Right	Thru	Left	Peds	App. Total	
04:00 PM	0	97	7	1	105	0	20	16	1	37	0	0	0	4	4	13	4	0	4	21	167
04:15 PM	4	70	4	2	80	0	28	16	1	45	0	0	0	1	1	10	10	0	1	21	147
04:30 PM	0	95	2	2	99	0	14	27	1	42	0	0	0	5	5	12	7	0	4	23	169
04:45 PM	3	92	11	2	108	0	23	15	1	39	0	0	0	2	2	17	12	0	8	37	186
Total	7	354	24	7	392	0	85	74	4	163	0	0	0	12	12	52	33	0	17	102	669
05:00 PM	3	232	16	1	252	0	21	22	0	43	0	0	0	3	3	32	29	0	2	63	361
05:15 PM	11	133	9	5	158	0	37	31	0	68	0	0	0	5	5	14	10	0	2	26	257
05:30 PM	1	175	14	14	204	0	31	24	4	59	0	0	0	12	12	37	18	0	7	62	337
05:45 PM	1	142	9	5	157	0	20	29	3	52	0	0	0	3	3	13	13	0	3	29	241
Total	16	682	48	25	771	0	109	106	7	222	0	0	0	23	23	96	70	0	14	180	1196
Grand Total	23	1036	72	32	1163	0	194	180	11	385	0	0	0	35	35	148	103	0	31	282	1865
Apprch %	2	89.1	6.2	2.8		0	50.4	46.8	2.9		0	0	0	100		52.5	36.5	0	11		
Total %	1.2	55.5	3.9	1.7	62.4	0	10.4	9.7	0.6	20.6	0	0	0	1.9	1.9	7.9	5.5	0	1.7	15.1	

Start Time	S. MONTGOMERY ST Southbound				W. SAN FERNANDO ST Westbound				S. MONTGOMERY ST Northbound				W. SAN FERNANDO ST Eastbound				Int. Total
	Right	Thru	Left	App. Total	Right	Thru	Left	App. Total	Right	Thru	Left	App. Total	Right	Thru	Left	App. Total	
05:00 PM	3	232	16	251	0	21	22	43	0	0	0	0	32	29	0	61	355
05:15 PM	11	133	9	153	0	37	31	68	0	0	0	0	14	10	0	24	245
05:30 PM	1	175	14	190	0	31	24	55	0	0	0	0	37	18	0	55	300
05:45 PM	1	142	9	152	0	20	29	49	0	0	0	0	13	13	0	26	227
Total Volume	16	682	48	746	0	109	106	215	0	0	0	0	96	70	0	166	1127
% App. Total	2.1	91.4	6.4		0	50.7	49.3		0	0	0		57.8	42.2	0		
PHF	.364	.735	.750	.743	.000	.736	.855	.790	.000	.000	.000	.000	.649	.603	.000	.680	.794

Peak Hour Analysis From 04:00 PM to 05:45 PM - Peak 1 of 1

Peak Hour for Entire Intersection Begins at 05:00 PM

Traffic Data Service

Campbell, CA

(408) 377-2988

tdsbay@cs.com

File Name : 101PM FINAL

Site Code : 00000101

Start Date : 6/4/2013

Page No : 2

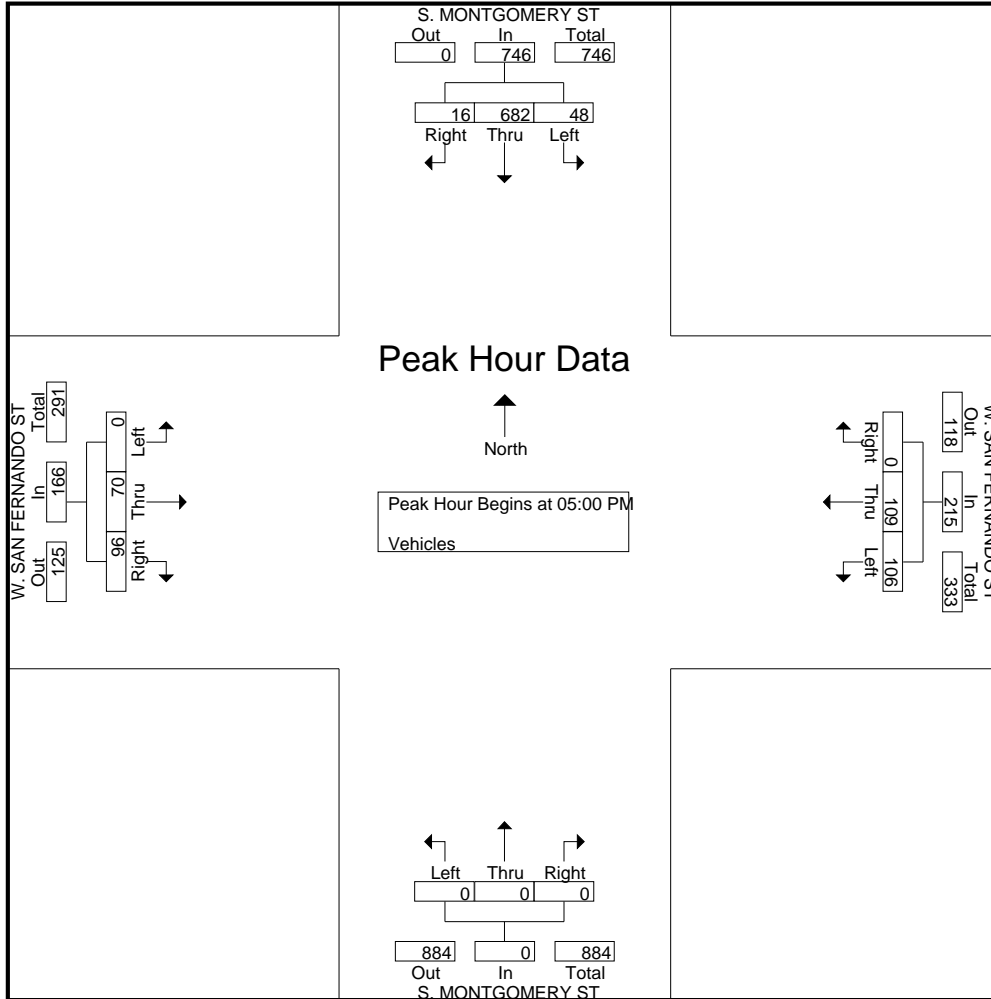

Traffic Data Service

Campbell, CA
 (408) 377-2988
 tdsbay@cs.com

File Name : 101PM FINAL
 Site Code : 00000101
 Start Date : 6/4/2013
 Page No : 1

Groups Printed- Bikes

Start Time	S. MONTGOMERY ST Southbound					W. SAN FERNANDO ST Westbound					S. MONTGOMERY ST Northbound					W. SAN FERNANDO ST Eastbound					Int. Total
	Right	Thru	Left	Peds	App. Total	Right	Thru	Left	Peds	App. Total	Right	Thru	Left	Peds	App. Total	Right	Thru	Left	Peds	App. Total	
04:00 PM	0	0	0	0	0	0	6	1	0	7	0	0	0	0	0	1	0	0	0	1	8
04:15 PM	0	0	1	0	1	0	5	0	0	5	0	0	0	0	0	0	0	0	0	0	6
04:30 PM	0	0	0	0	0	0	3	0	0	3	0	0	0	0	0	0	1	0	0	1	4
04:45 PM	0	0	0	0	0	0	2	0	0	2	0	0	0	0	0	2	0	0	0	2	4
Total	0	0	1	0	1	0	16	1	0	17	0	0	0	0	0	3	1	0	0	4	22
05:00 PM	0	2	1	0	3	0	3	1	0	4	0	0	0	0	0	5	2	0	0	7	14
05:15 PM	0	0	0	0	0	0	7	3	0	10	0	0	0	0	0	0	0	0	0	0	10
05:30 PM	0	3	2	0	5	0	3	0	0	3	0	0	0	0	0	7	5	0	0	12	20
05:45 PM	0	3	0	0	3	0	1	1	0	2	0	0	0	0	0	0	4	0	0	4	9
Total	0	8	3	0	11	0	14	5	0	19	0	0	0	0	0	12	11	0	0	23	53
Grand Total	0	8	4	0	12	0	30	6	0	36	0	0	0	0	0	15	12	0	0	27	75
Apprch %	0	66.7	33.3	0		0	83.3	16.7	0		0	0	0	0		55.6	44.4	0	0		
Total %	0	10.7	5.3	0	16	0	40	8	0	48	0	0	0	0	0	20	16	0	0	36	

Start Time	S. MONTGOMERY ST Southbound				W. SAN FERNANDO ST Westbound				S. MONTGOMERY ST Northbound				W. SAN FERNANDO ST Eastbound				Int. Total
	Right	Thru	Left	App. Total	Right	Thru	Left	App. Total	Right	Thru	Left	App. Total	Right	Thru	Left	App. Total	
Peak Hour Analysis From 04:00 PM to 05:45 PM - Peak 1 of 1																	
Peak Hour for Entire Intersection Begins at 05:00 PM																	
05:00 PM	0	2	1	3	0	3	1	4	0	0	0	0	5	2	0	7	14
05:15 PM	0	0	0	0	0	7	3	10	0	0	0	0	0	0	0	0	10
05:30 PM	0	3	2	5	0	3	0	3	0	0	0	0	7	5	0	12	20
05:45 PM	0	3	0	3	0	1	1	2	0	0	0	0	0	4	0	4	9
Total Volume	0	8	3	11	0	14	5	19	0	0	0	0	12	11	0	23	53
% App. Total	0	72.7	27.3		0	73.7	26.3		0	0	0		52.2	47.8	0		
PHF	.000	.667	.375	.550	.000	.500	.417	.475	.000	.000	.000	.000	.429	.550	.000	.479	.663

Traffic Data Service

Campbell, CA
(408) 377-2988
tdsbay@cs.com

File Name : 101PM FINAL
Site Code : 00000101
Start Date : 6/4/2013
Page No : 2

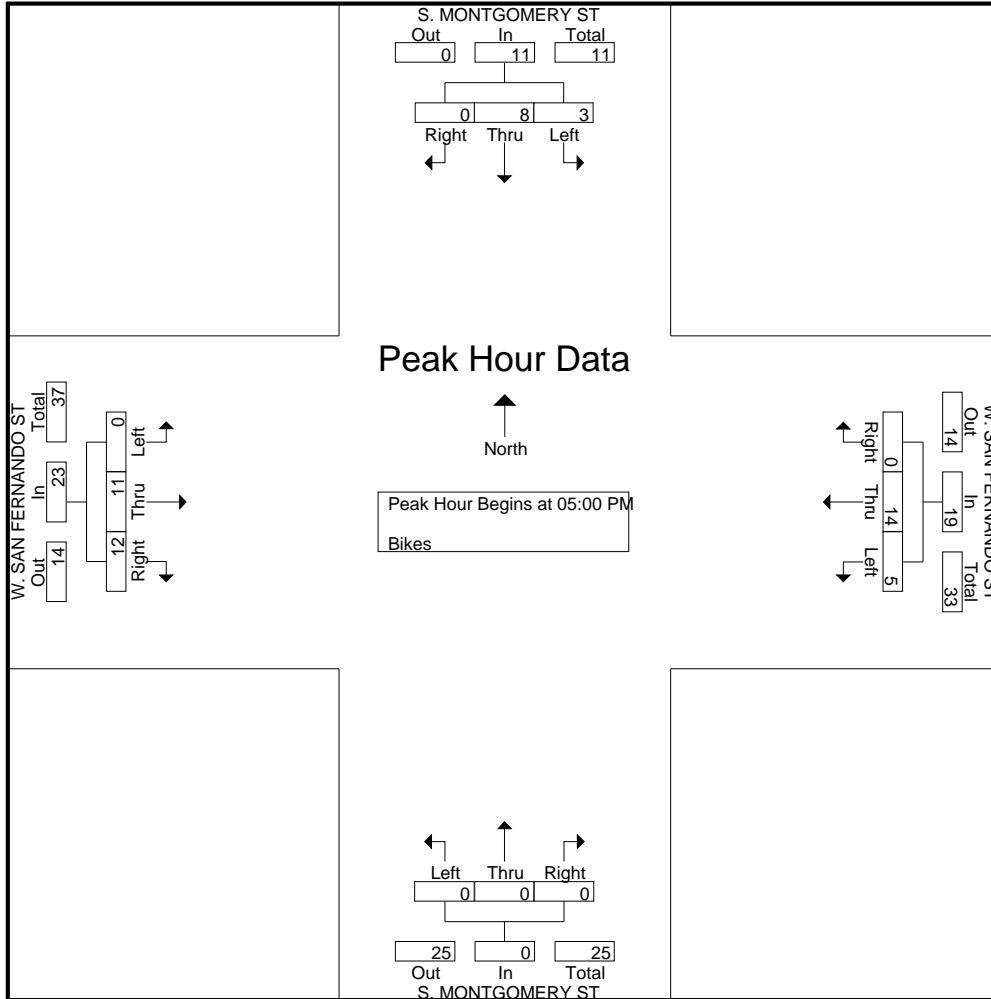

Traffic Data Service

Campbell, CA
 (408) 377-2988
 tdsbay@cs.com

File Name : 30AM FINAL
 Site Code : 00000030
 Start Date : 5/23/2013
 Page No : 1

Groups Printed- Vehicles

Start Time	LICK AVE Southbound					W. ALMA AVE Westbound					SHADOW RUN DR Northbound					W. ALMA AVE Eastbound					Int. Total
	Right	Thru	Left	Peds	App. Total	Right	Thru	Left	Peds	App. Total	Right	Thru	Left	Peds	App. Total	Right	Thru	Left	Peds	App. Total	
07:00 AM	6	0	20	4	30	19	146	1	0	166	2	1	9	0	12	2	75	3	1	81	289
07:15 AM	2	0	7	2	11	25	129	0	0	154	4	4	15	5	28	0	80	6	2	88	281
07:30 AM	10	0	14	5	29	51	139	0	0	190	6	4	14	5	29	2	99	8	6	115	363
07:45 AM	12	0	17	0	29	62	131	0	0	193	2	2	6	0	10	4	123	12	3	142	374
Total	30	0	58	11	99	157	545	1	0	703	14	11	44	10	79	8	377	29	12	426	1307
08:00 AM	10	0	14	4	28	16	153	0	0	169	1	3	8	0	12	1	88	3	1	93	302
08:15 AM	6	1	9	2	18	30	147	0	0	177	2	2	2	2	8	1	100	6	4	111	314
08:30 AM	11	1	6	2	20	19	116	1	1	137	3	1	8	1	13	2	101	2	1	106	276
08:45 AM	15	0	3	4	22	17	122	0	0	139	3	4	8	2	17	5	112	6	2	125	303
Total	42	2	32	12	88	82	538	1	1	622	9	10	26	5	50	9	401	17	8	435	1195
Grand Total	72	2	90	23	187	239	1083	2	1	1325	23	21	70	15	129	17	778	46	20	861	2502
Apprch %	38.5	1.1	48.1	12.3		18	81.7	0.2	0.1		17.8	16.3	54.3	11.6		2	90.4	5.3	2.3		
Total %	2.9	0.1	3.6	0.9	7.5	9.6	43.3	0.1	0	53	0.9	0.8	2.8	0.6	5.2	0.7	31.1	1.8	0.8	34.4	

Start Time	LICK AVE Southbound				W. ALMA AVE Westbound				SHADOW RUN DR Northbound				W. ALMA AVE Eastbound				Int. Total
	Right	Thru	Left	App. Total	Right	Thru	Left	App. Total	Right	Thru	Left	App. Total	Right	Thru	Left	App. Total	
Peak Hour Analysis From 07:00 AM to 08:45 AM - Peak 1 of 1																	
Peak Hour for Entire Intersection Begins at 07:30 AM																	
07:30 AM	10	0	14	24	51	139	0	190	6	4	14	24	2	99	8	109	347
07:45 AM	12	0	17	29	62	131	0	193	2	2	6	10	4	123	12	139	371
08:00 AM	10	0	14	24	16	153	0	169	1	3	8	12	1	88	3	92	297
08:15 AM	6	1	9	16	30	147	0	177	2	2	2	6	1	100	6	107	306
Total Volume	38	1	54	93	159	570	0	729	11	11	30	52	8	410	29	447	1321
% App. Total	40.9	1.1	58.1		21.8	78.2	0		21.2	21.2	57.7		1.8	91.7	6.5		
PHF	.792	.250	.794	.802	.641	.931	.000	.944	.458	.688	.536	.542	.500	.833	.604	.804	.890

Traffic Data Service

Campbell, CA
(408) 377-2988
tdsbay@cs.com

File Name : 30AM FINAL
Site Code : 00000030
Start Date : 5/23/2013
Page No : 2

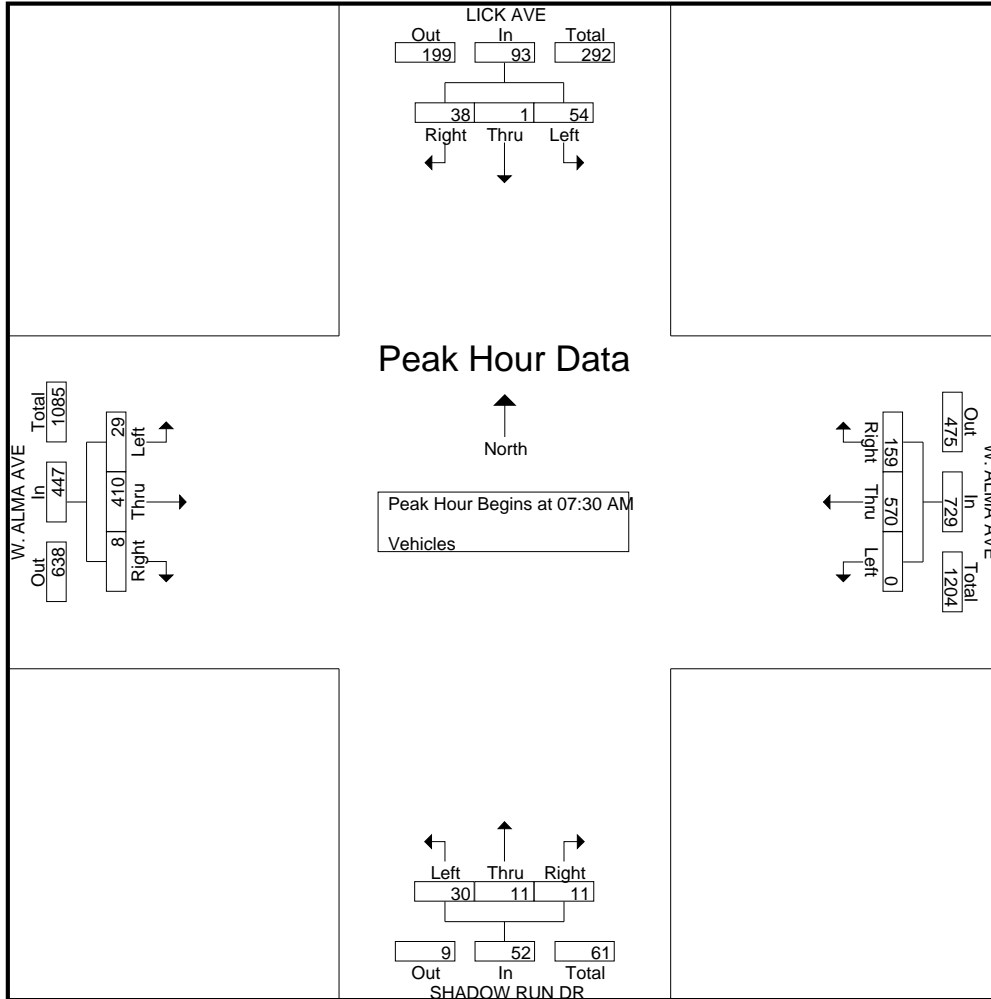

Traffic Data Service

Campbell, CA
 (408) 377-2988
 tdsbay@cs.com

File Name : 30AM FINAL
 Site Code : 00000030
 Start Date : 5/23/2013
 Page No : 1

Groups Printed- Bikes

Start Time	LICK AVE Southbound					W. ALMA AVE Westbound					SHADOW RUN DR Northbound					W. ALMA AVE Eastbound					Int. Total
	Right	Thru	Left	Peds	App. Total	Right	Thru	Left	Peds	App. Total	Right	Thru	Left	Peds	App. Total	Right	Thru	Left	Peds	App. Total	
07:00 AM	0	0	1	0	1	0	1	0	0	1	0	0	0	0	0	0	0	0	0	0	2
07:15 AM	0	0	0	0	0	0	1	0	0	1	0	0	0	0	0	0	0	0	0	0	1
07:30 AM	0	0	0	0	0	0	0	0	0	0	0	1	0	0	1	0	0	0	0	0	1
07:45 AM	0	0	0	0	0	0	0	0	0	0	0	0	0	0	0	0	0	0	0	0	0
Total	0	0	1	0	1	0	2	0	0	2	0	1	0	0	1	0	0	0	0	0	4
08:00 AM	0	0	0	0	0	0	1	0	0	1	0	0	0	0	0	0	0	0	0	0	1
08:15 AM	0	0	0	0	0	1	0	0	0	1	0	0	0	0	0	0	0	0	0	0	1
08:30 AM	0	0	0	0	0	0	0	0	0	0	0	0	0	0	0	0	0	0	0	0	0
08:45 AM	0	0	0	0	0	0	0	0	0	0	0	0	0	0	0	0	1	0	0	1	1
Total	0	0	0	0	0	1	1	0	0	2	0	0	0	0	0	0	1	0	0	1	3
Grand Total	0	0	1	0	1	1	3	0	0	4	0	1	0	0	1	0	1	0	0	1	7
Apprch %	0	0	100	0		25	75	0	0		0	100	0	0		0	100	0	0		
Total %	0	0	14.3	0	14.3	14.3	42.9	0	0	57.1	0	14.3	0	0	14.3	0	14.3	0	0	14.3	

Start Time	LICK AVE Southbound				W. ALMA AVE Westbound				SHADOW RUN DR Northbound				W. ALMA AVE Eastbound				Int. Total
	Right	Thru	Left	App. Total	Right	Thru	Left	App. Total	Right	Thru	Left	App. Total	Right	Thru	Left	App. Total	
07:00 AM	0	0	1	1	0	1	0	1	0	0	0	0	0	0	0	0	2
07:15 AM	0	0	0	0	0	1	0	1	0	0	0	0	0	0	0	0	1
07:30 AM	0	0	0	0	0	0	0	0	0	1	0	1	0	0	0	0	1
07:45 AM	0	0	0	0	0	0	0	0	0	0	0	0	0	0	0	0	0
Total Volume	0	0	1	1	0	2	0	2	0	1	0	1	0	0	0	0	4
% App. Total	0	0	100		0	100	0		0	100	0		0	0	0		
PHF	.000	.000	.250	.250	.000	.500	.000	.500	.000	.250	.000	.250	.000	.000	.000	.000	.500

Peak Hour Analysis From 07:00 AM to 08:45 AM - Peak 1 of 1

Peak Hour for Entire Intersection Begins at 07:00 AM

Traffic Data Service

Campbell, CA

(408) 377-2988

tdsbay@cs.com

File Name : 30AM FINAL

Site Code : 00000030

Start Date : 5/23/2013

Page No : 2

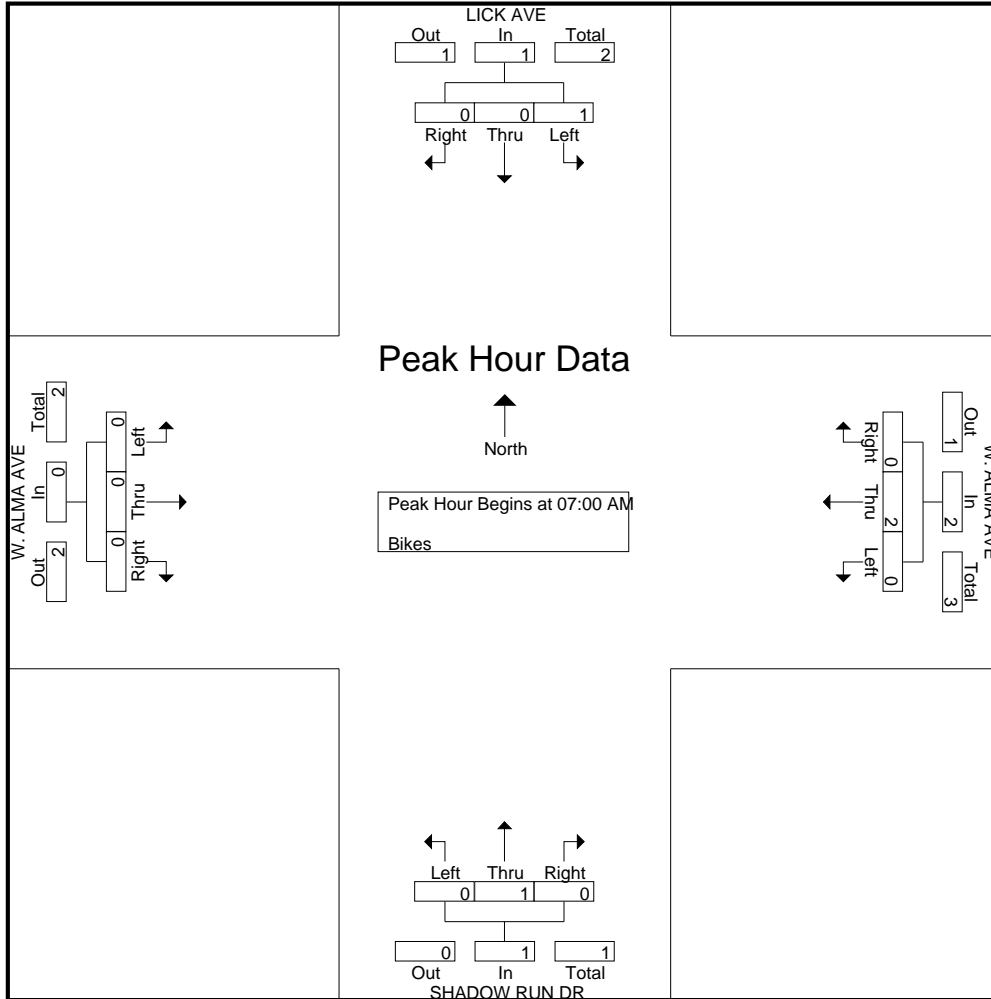

Traffic Data Service

Campbell, CA
 (408) 377-2988
 tdsbay@cs.com

File Name : 30PM FINAL
 Site Code : 00000030
 Start Date : 5/23/2013
 Page No : 1

Groups Printed- Vehicles

Start Time	LICK AVE Southbound					W. ALMA AVE Westbound					SHADOW RUN DR Northbound					W. ALMA AVE Eastbound					Int. Total
	Right	Thru	Left	Peds	App. Total	Right	Thru	Left	Peds	App. Total	Right	Thru	Left	Peds	App. Total	Right	Thru	Left	Peds	App. Total	
04:00 PM	9	1	14	2	26	9	137	2	0	148	2	1	3	6	12	3	157	2	3	165	351
04:15 PM	11	1	11	3	26	8	125	1	0	134	0	0	6	2	8	8	155	6	1	170	338
04:30 PM	7	2	8	2	19	10	140	1	0	151	3	0	3	4	10	5	145	4	5	159	339
04:45 PM	23	2	14	1	40	6	110	6	0	122	1	0	2	2	5	11	151	7	0	169	336
Total	50	6	47	8	111	33	512	10	0	555	6	1	14	14	35	27	608	19	9	663	1364
05:00 PM	12	1	27	2	42	8	167	3	0	178	1	0	4	1	6	8	107	13	2	130	356
05:15 PM	12	2	30	5	49	14	138	3	1	156	2	2	5	1	10	10	122	9	1	142	357
05:30 PM	7	3	15	9	34	14	137	2	0	153	2	0	5	8	15	12	125	12	10	159	361
05:45 PM	23	1	94	3	121	15	116	2	0	133	2	0	6	0	8	6	132	16	8	162	424
Total	54	7	166	19	246	51	558	10	1	620	7	2	20	10	39	36	486	50	21	593	1498
Grand Total	104	13	213	27	357	84	1070	20	1	1175	13	3	34	24	74	63	1094	69	30	1256	2862
Apprch %	29.1	3.6	59.7	7.6		7.1	91.1	1.7	0.1		17.6	4.1	45.9	32.4		5	87.1	5.5	2.4		
Total %	3.6	0.5	7.4	0.9	12.5	2.9	37.4	0.7	0	41.1	0.5	0.1	1.2	0.8	2.6	2.2	38.2	2.4	1	43.9	

Start Time	LICK AVE Southbound				W. ALMA AVE Westbound				SHADOW RUN DR Northbound				W. ALMA AVE Eastbound				Int. Total
	Right	Thru	Left	App. Total	Right	Thru	Left	App. Total	Right	Thru	Left	App. Total	Right	Thru	Left	App. Total	
Peak Hour Analysis From 04:00 PM to 05:45 PM - Peak 1 of 1																	
Peak Hour for Entire Intersection Begins at 05:00 PM																	
05:00 PM	12	1	27	40	8	167	3	178	1	0	4	5	8	107	13	128	351
05:15 PM	12	2	30	44	14	138	3	155	2	2	5	9	10	122	9	141	349
05:30 PM	7	3	15	25	14	137	2	153	2	0	5	7	12	125	12	149	334
05:45 PM	23	1	94	118	15	116	2	133	2	0	6	8	6	132	16	154	413
Total Volume	54	7	166	227	51	558	10	619	7	2	20	29	36	486	50	572	1447
% App. Total	23.8	3.1	73.1		8.2	90.1	1.6		24.1	6.9	69		6.3	85	8.7		
PHF	.587	.583	.441	.481	.850	.835	.833	.869	.875	.250	.833	.806	.750	.920	.781	.929	.876

Traffic Data Service

Campbell, CA

(408) 377-2988

tdsbay@cs.com

File Name : 30PM FINAL

Site Code : 00000030

Start Date : 5/23/2013

Page No : 2

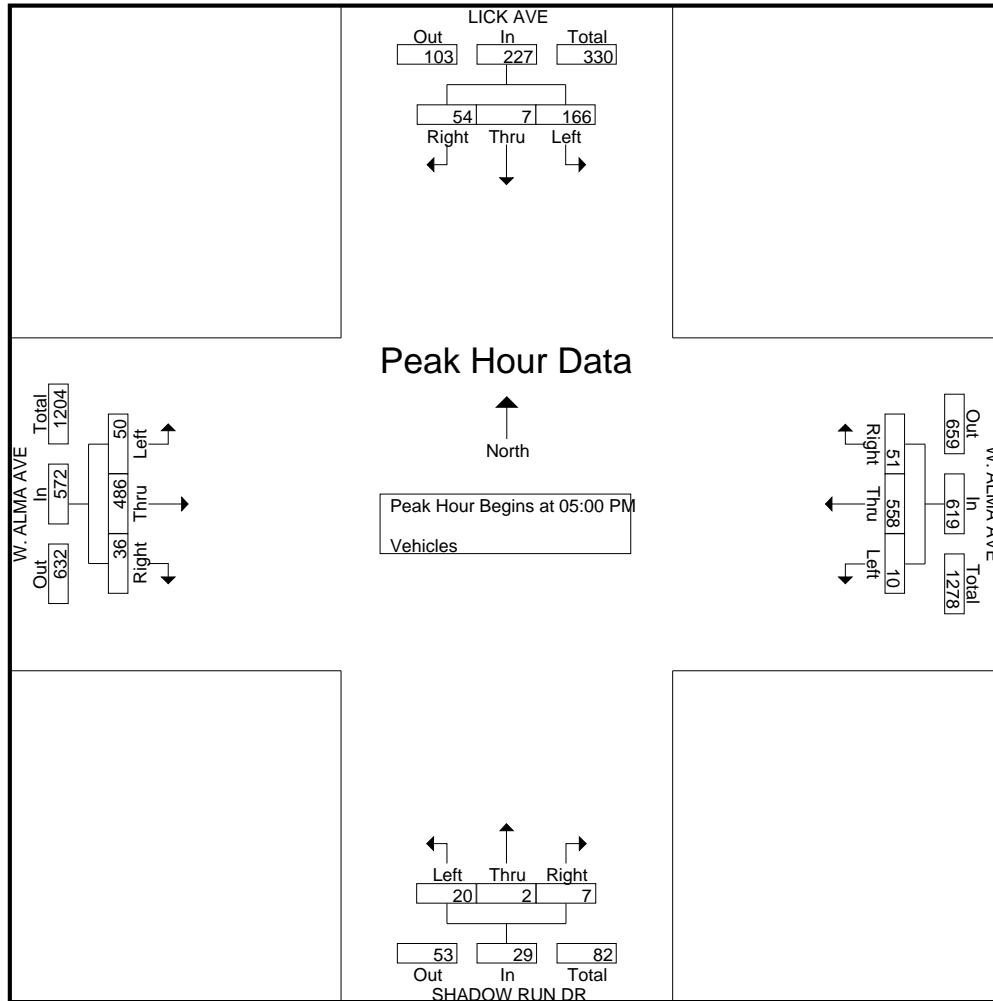

Traffic Data Service

Campbell, CA
(408) 377-2988
tdsbay@cs.com

File Name : 30PM FINAL
Site Code : 00000030
Start Date : 5/23/2013
Page No : 1

Groups Printed- Bikes

Start Time	LICK AVE Southbound					W. ALMA AVE Westbound					SHADOW RUN DR Northbound					W. ALMA AVE Eastbound					Int. Total
	Right	Thru	Left	Peds	App. Total	Right	Thru	Left	Peds	App. Total	Right	Thru	Left	Peds	App. Total	Right	Thru	Left	Peds	App. Total	
04:00 PM	0	0	1	0	1	0	0	0	0	0	0	0	0	0	0	0	0	0	0	0	1
04:15 PM	0	0	3	0	3	1	0	0	0	1	0	0	0	0	0	0	0	0	0	0	4
04:30 PM	0	0	1	0	1	1	0	0	0	1	0	0	0	0	0	0	1	1	0	0	4
04:45 PM	0	0	0	0	0	0	0	0	0	0	0	0	0	0	0	0	1	0	0	0	1
Total	0	0	5	0	5	2	0	0	0	2	0	0	0	0	0	0	2	1	0	3	10
05:00 PM	0	0	0	0	0	0	1	0	0	1	0	0	0	0	0	0	0	0	0	0	1
05:15 PM	0	0	0	0	0	0	0	0	0	0	0	0	0	0	0	0	0	0	0	0	0
05:30 PM	0	0	0	0	0	0	0	0	0	0	0	0	0	0	0	0	1	0	0	0	1
05:45 PM	0	0	1	0	1	0	0	0	0	0	0	0	0	0	0	0	2	0	0	0	3
Total	0	0	1	0	1	0	1	0	0	1	0	0	0	0	0	0	3	0	0	3	5
Grand Total	0	0	6	0	6	2	1	0	0	3	0	0	0	0	0	0	5	1	0	6	15
Apprch %	0	0	100	0		66.7	33.3	0	0		0	0	0	0		0	83.3	16.7	0		
Total %	0	0	40	0	40	13.3	6.7	0	0	20	0	0	0	0	0	0	33.3	6.7	0	40	

Start Time	LICK AVE Southbound				W. ALMA AVE Westbound				SHADOW RUN DR Northbound				W. ALMA AVE Eastbound				Int. Total
	Right	Thru	Left	App. Total	Right	Thru	Left	App. Total	Right	Thru	Left	App. Total	Right	Thru	Left	App. Total	
Peak Hour Analysis From 04:00 PM to 05:45 PM - Peak 1 of 1																	
Peak Hour for Entire Intersection Begins at 04:00 PM																	
04:00 PM	0	0	1	1	0	0	0	0	0	0	0	0	0	0	0	0	1
04:15 PM	0	0	3	3	1	0	0	1	0	0	0	0	0	0	0	0	4
04:30 PM	0	0	1	1	1	0	0	1	0	0	0	0	0	1	1	0	4
04:45 PM	0	0	0	0	0	0	0	0	0	0	0	0	0	1	0	0	1
Total Volume	0	0	5	5	2	0	0	2	0	0	0	0	0	2	1	3	10
% App. Total	0	0	100		100	0	0		0	0	0		0	66.7	33.3		
PHF	.000	.000	.417	.417	.500	.000	.000	.500	.000	.000	.000	.000	.000	.500	.250	.375	.625

Traffic Data Service

Campbell, CA

(408) 377-2988

tdsbay@cs.com

File Name : 30PM FINAL

Site Code : 00000030

Start Date : 5/23/2013

Page No : 2

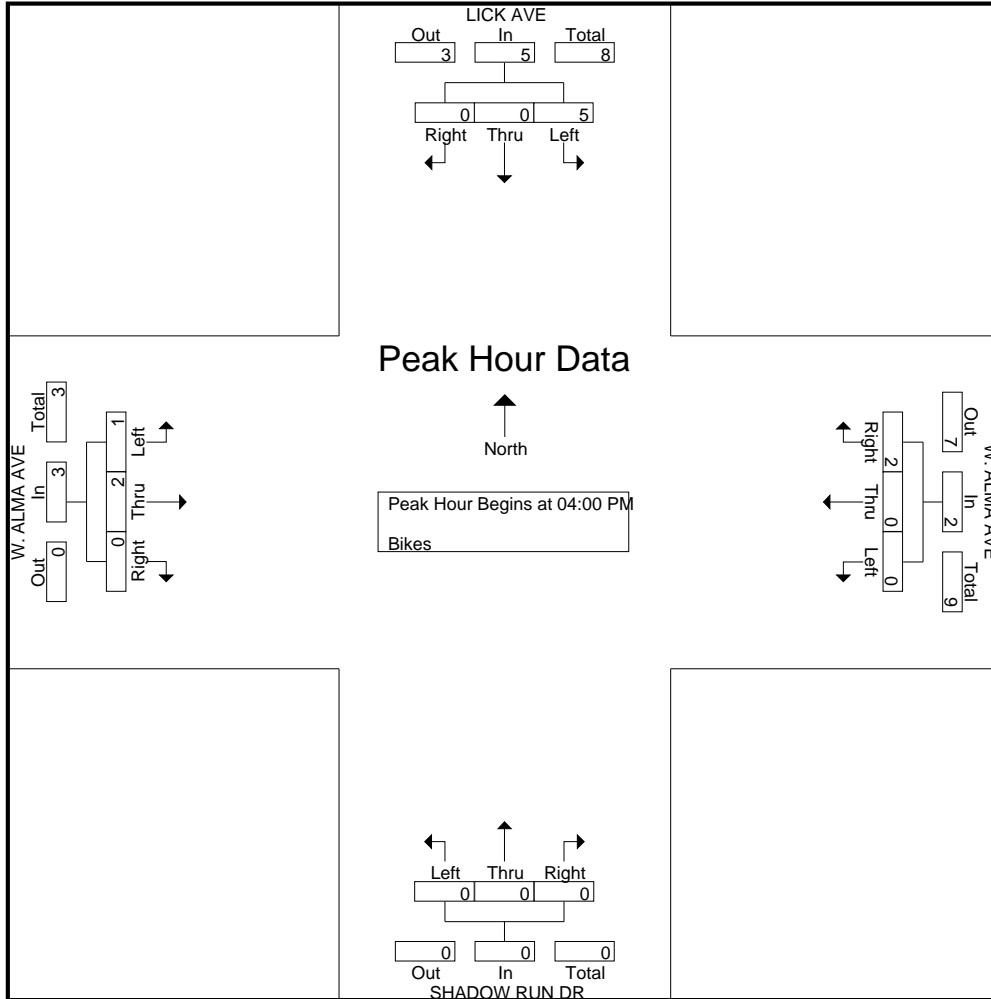

**ATTACHMENT I EXISTING CALTRAIN
SCHEDULE (2013)**



Printer-Friendly Caltrain Schedule

Northbound - Weekday Service

Morning to Early Afternoon - Page 1 of 2



GILROY / SAN JOSE to SAN FRANCISCO - Northbound

WEEKDAY SERVICE

See Page 2 For Early Afternoon and Evening Times

Train #	101	103	305	207	309	211	313	215	217	319	221	323	225	227	329	231	233	135	237	139	143	147	151	155	257
Gilroy									6:07		6:28			7:05											
San Martin	AM								6:16		6:37			7:14							AM	PM			
Morgan Hill									6:22		6:43			7:20											
Blossom Hill									6:35		6:56			7:33											
Capitol									6:41		7:02			7:39											
Tamien	-	4:58		5:50	5:56				6:49	6:56	7:10			7:47	7:56		8:33		9:33						2:33
San Jose Diridon	4:30	5:05	5:45	5:57	6:03	6:20	6:45	6:50	6:57	7:03	7:18	7:45	7:50	7:55	8:03	8:20	8:40	9:10	9:40	10:10	11:10	12:10	1:10	2:10	2:40
College Park	-	-	-	-	-	-	-	-	-	-	-	-	-	7:58	-	-	-	-	-	-	-	-	-	-	-
Santa Clara	4:35	5:10	-	6:02	-	6:25	-	-	7:02	-	7:23	-	-	8:02	-	8:25	8:45	9:15	9:45	10:15	11:15	12:15	1:15	2:15	2:45
Lawrence	4:40	5:15	-	6:12	-	-	-	-	7:12	-	7:28	-	-	8:12	-	-	8:50	9:20	9:50	10:20	11:20	12:20	1:20	2:20	2:50
Sunnyvale	4:44	5:19	-	6:18	6:13	6:32	-	7:00	7:18	7:13	7:32	-	8:00	8:18	8:13	8:32	8:54	9:24	9:54	10:24	11:24	12:24	1:24	2:24	2:54
Mountain View	4:49	5:24	5:57	6:23	-	6:37	6:57	7:05	7:23	-	7:37	7:57	8:05	8:23	-	8:37	8:59	9:29	9:59	10:29	11:29	12:29	1:29	2:29	2:59
San Antonio	4:53	5:28	-	6:27	-	-	-	-	7:27	-	-	-	-	8:27	-	-	9:03	9:33	10:03	10:33	11:33	12:33	1:33	2:33	3:03
California Avenue	4:57	5:32	-	6:31	-	-	-	7:11	7:31	-	-	-	8:11	8:31	-	9:07	9:37	10:07	10:37	11:37	12:37	1:37	2:37	3:07	
Palo Alto	5:01	5:36	6:05	6:36	6:23	-	7:05	7:16	7:36	7:23	-	8:05	8:16	8:36	8:23	-	9:11	9:41	10:11	10:41	11:41	12:41	1:41	2:41	3:11
Menlo Park	5:04	5:39	-	6:39	-	6:45	-	-	7:39	-	7:45	-	-	8:39	-	8:45	9:14	9:44	10:14	10:44	11:44	12:44	1:44	2:44	3:14
Redwood City	5:09	5:44	-	6:45	6:30	6:51	-	-	7:45	7:30	7:51	-	-	8:45	8:30	8:51	9:19	9:49	10:19	10:49	11:49	12:49	1:49	2:49	3:19
San Carlos	5:13	5:48	-	-	-	6:55	-	7:24	-	-	7:55	-	8:24	-	-	8:55	9:23	9:53	10:23	10:53	11:53	12:53	1:53	2:53	3:23
Belmont	5:16	5:51	-	-	-	6:58	-	-	-	-	7:58	-	-	-	-	8:58	9:26	9:56	10:26	10:56	11:56	12:56	1:56	2:56	3:26
Hillsdale	5:19	5:54	6:16	6:51	-	7:02	7:16	7:28	7:51	-	8:02	8:16	8:28	8:51	-	9:02	9:29	9:59	10:29	10:59	11:59	12:59	1:59	2:59	3:29
Hayward Park	5:22	5:57	-	-	-	7:05	-	-	-	-	8:05	-	-	-	-	9:05	-	10:02	-	11:02	12:02	1:02	2:02	3:02	-
San Mateo	5:25	6:00	-	-	6:39	7:08	-	7:32	-	7:39	8:08	-	8:32	-	8:39	9:08	9:33	10:05	10:33	11:05	12:05	1:05	2:05	3:05	3:33
Burlingame	5:28	6:03	-	-	-	7:11	-	7:35	-	-	8:11	-	8:35	-	-	9:11	9:36	10:08	10:36	11:08	12:08	1:08	2:08	3:08	3:36
Millbrae	5:33	6:08	6:24	6:59	6:45	7:17	7:24	-	7:59	7:45	8:17	8:24	-	8:59	8:45	9:17	9:41	10:13	10:41	11:13	12:13	1:13	2:13	3:13	3:41
San Bruno	5:37	6:12	-	-	-	7:21	-	7:42	-	-	8:21	-	8:42	-	-	9:21	9:45	10:17	10:45	11:17	12:17	1:17	2:17	3:17	3:45
So. San Francisco	5:41	6:16	-	7:05	-	7:25	-	-	8:05	-	8:25	-	-	9:05	-	9:25	-	10:21	-	11:21	12:21	1:21	2:21	3:21	-
Bayshore	5:47	6:22	-	-	-	7:33+	-	-	-	-	8:33+	-	-	-	-	9:31	-	10:27	-	11:27	12:27	1:27	2:27	3:27	-
22nd Street	5:52	6:27	-	-	-	7:40+	-	-	-	-	8:40+	-	-	-	-	9:37	-	10:32	-	11:32	12:32	1:32	2:32	3:32	-
San Francisco	6:01	6:36	6:42	7:19	7:02	7:48	7:42	7:57	8:19	8:02	8:48	8:42	8:57	9:19	9:02	9:45	10:02	10:41	11:02	11:41	12:41	1:41	2:41	3:41	4:02

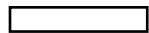

Local



Limited



Baby Bullet



Timed Transfers

- Train bypasses station.

+ Train may leave up to 5 minutes early.

EFFECTIVE OCTOBER 1, 2012

Printer-Friendly Caltrain Schedule

Northbound - Weekday Service

Early Afternoon to Evening - Page 2 of 2



GILROY / SAN JOSE to SAN FRANCISCO - Northbound

WEEKDAY SERVICE

See Page 1 For Morning and Early Afternoon Times

	159	261	263	365	267	269	371	273	375	277	NORTHBOUND	279	381	283	385	287	289	191	193	195	197	*199	
PM											Gilroy												PM
											San Martin												
											Morgan Hill												
											Blossom Hill												
											Capitol												
											Tamien	5:32		5:58		6:24					8:23	9:23	
	3:05	3:37	3:58	4:23	4:31	4:39	4:45	5:05	5:23	5:31	San Jose Diridon	5:39	5:45	6:05	6:23	6:31	6:45	6:50	7:30	8:30	9:30	10:30	
	3:08	-	-	-	-	-	-	-	-	-	College Park	-	-	-	-	-	-	-	-	-	-	-	-
	3:12	3:49	4:10	-	-	4:44	-	5:10	-	-	Santa Clara	5:44	-	6:10	-	-	-	6:55	7:35	8:35	9:35	10:35	
	3:17	3:54	-	-	4:39	4:52	-	-	-	5:39	Lawrence	5:52	-	-	-	6:39	6:53	7:00	7:40	8:40	9:40	10:40	
	3:21	3:58	-	-	-	4:58	-	-	-	-	Sunnyvale	5:58	-	-	-	-	-	7:04	7:44	8:44	9:44	10:44	
	3:26	4:03	-	4:35	4:46	5:03	4:58	-	5:35	5:46	Mountain View	6:03	5:58	-	6:35	6:46	7:00	7:09	7:49	8:49	9:49	10:49	
	3:30	4:07	-	-	-	5:07	-	-	-	-	San Antonio	6:07	-	-	-	-	-	7:13	7:53	8:53	9:53	10:53	
	3:34	4:11	-	-	-	5:11	-	-	-	-	California Avenue	6:11	-	-	-	-	7:06	7:17	7:57	8:57	9:57	10:57	
	3:38	4:16	4:24	4:43	4:54	5:16	5:06	5:24	5:43	5:54	Palo Alto	6:16	6:06	6:24	6:43	6:54	7:10	7:21	8:01	9:01	10:01	11:01	
	3:41	4:19	-	4:46	4:57	5:19	-	-	5:46	5:57	Menlo Park	6:19	-	-	6:46	6:57	7:13	7:24	8:04	9:04	10:04	11:04	
	3:46	4:25	4:31	4:52	-	5:25	-	5:31	5:52	-	Redwood City	6:25	-	6:31	6:52	-	7:19	7:29	8:09	9:09	10:09	11:09	
	3:50	4:29	4:35	-	5:04	5:29	-	5:35	-	6:04	San Carlos	6:29	-	6:35	-	7:04	7:23	7:33	8:13	9:13	10:13	11:13	
	3:53	-	4:38	-	-	-	-	5:38	-	-	Belmont	-	-	6:38	-	-	-	7:36	8:16	9:16	10:16	11:16	
	3:56	-	4:42	-	5:08	-	5:17	5:42	-	6:08	Hillsdale	-	6:17	6:42	-	7:08	7:28	7:39	8:19	9:19	10:19	11:19	
	3:59	-	4:45	-	-	-	-	5:45	-	-	Hayward Park	-	-	6:45	-	-	-	7:42	8:22	9:22	10:22	11:22	
	4:02	4:36	4:48	-	5:12	5:36	-	5:48	-	6:12	San Mateo	6:36	-	6:48	-	7:12	7:32	7:45	8:25	9:25	10:25	11:25	
	4:05	-	4:51	-	5:15	-	-	5:51	-	6:15	Burlingame	-	-	6:51	-	7:15	7:35	7:48	8:28	9:28	10:28	11:28	
	4:10	4:43	4:57	5:05	-	5:43	5:25	5:57	6:05	-	Millbrae	6:43	6:25	6:57	7:05	-	7:41	7:53	8:33	9:33	10:33	11:33	
	4:14	-	5:01	-	5:22	-	-	6:01	-	6:22	San Bruno	-	-	7:01	-	7:22	-	7:57	8:37	9:37	10:37	11:37	
	4:18	-	5:05	-	-	-	-	6:05	-	-	So. San Francisco	-	-	7:05	-	-	-	8:01	8:41	9:41	10:41	11:41	
	4:24	-	5:13+	-	-	-	-	6:13+	-	-	Bayshore	-	-	7:13+	-	-	-	8:07	8:47	9:47	10:47	11:47	
	4:29	4:55	5:21+	5:17	-	5:55	5:37	6:21+	6:17	-	22 nd Street	6:55	6:37	7:21+	7:17	-	7:53	8:12	8:52	9:52	10:52	11:52	
	4:38	5:03	5:29	5:24	5:39	6:02	5:44	6:29	6:24	6:39	San Francisco	7:02	6:44	7:29	7:24	7:39	8:00	8:21	9:01	10:01	11:01	12:01	

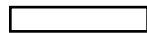

Local

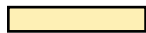

Limited



Baby Bullet



Timed Transfers

- Train bypasses station. + Train may leave up to 5 minutes early.

* Train departure may be delayed up to 15 minutes.

EFFECTIVE OCTOBER 1, 2012

10.12 - RJC

Printer-Friendly Caltrain Schedule

Southbound - Weekday Service

Morning to Early Afternoon - Page 1 of 2



SAN FRANCISCO to SAN JOSE / GILROY - Southbound

WEEKDAY SERVICE

See Page 2 For Early Afternoon and Evening Times

Train #	102	104	206	208	210	312	314	216	218	220	322	324	226	228	230	332	134	236	138	142	146	150	152	254
Zone 1 San Francisco	4:55	5:25	6:11	6:24	6:44	6:57	7:14	7:19	7:24	7:44	7:57	8:14	8:19	8:24	8:44	8:57	9:07	9:37	10:07	11:07	12:07	1:07	2:07	2:37
22 nd Street	5:00	5:30	6:16	6:29	6:49	7:02	7:19	-	7:29	7:49	8:02	8:19	-	8:29	8:49	9:02	9:12	-	10:12	11:12	12:12	1:12	2:12	-
Bayshore	5:05	5:35	-	6:34	-	-	-	-	7:34	-	-	-	-	8:34	-	-	9:17	-	10:17	11:17	12:17	1:17	2:17	-
So. San Francisco	5:11	5:41	-	6:40	-	-	-	-	7:40	-	-	-	-	8:40	-	-	9:23	-	10:23	11:23	12:23	1:23	2:23	-
San Bruno	5:15	5:45	-	6:44	-	-	-	7:33	7:44	-	-	-	8:33	8:44	-	-	9:27	9:51	10:27	11:27	12:27	1:27	2:27	2:51
Zone 2 Millbrae	5:19	5:49	6:29	6:48	7:01	7:15	7:32	-	7:48	8:01	8:15	8:32	-	8:48	9:01	9:15	9:31	9:55	10:31	11:31	12:31	1:31	2:31	2:55
Burlingame	5:23	5:53	6:33	6:52	-	-	-	7:38	7:52	-	-	-	8:38	8:52	-	-	9:35	9:59	10:35	11:35	12:35	1:35	2:35	2:59
San Mateo	5:26	5:56	6:36	6:55	7:07	-	-	7:42	7:55	8:07	-	-	8:42	8:55	9:07	-	9:38	10:02	10:38	11:38	12:38	1:38	2:38	3:02
Hayward Park	5:29	5:59	-	6:58	-	-	-	-	7:58	-	-	-	-	8:58	-	-	9:41	-	10:41	11:41	12:41	1:41	2:41	-
Hillsdale	5:32	6:02	6:40	7:01	-	-	7:40	7:46	8:01	-	-	8:40	8:46	9:01	-	-	9:44	10:06	10:44	11:44	12:44	1:44	2:44	3:06
Belmont	5:35	6:05	-	7:04	-	-	-	-	8:04	-	-	-	-	9:04	-	-	9:47	10:09	10:47	11:47	12:47	1:47	2:47	3:09
San Carlos	5:38	6:08	6:44	7:07	7:13	-	-	7:50	8:07	8:13	-	-	8:50	9:07	9:13	-	9:50	10:12	10:50	11:50	12:50	1:50	2:50	3:12
Redwood City	5:43	6:13	6:49	7:12	7:18	7:28	-	-	8:12	8:18	8:28	-	-	9:12	9:18	9:28	9:55	10:17	10:55	11:55	12:55	1:55	2:55	3:17
Zone 3 Menlo Park	5:48	6:18	6:54	-	7:23	7:33	-	7:58	-	8:23	8:33	-	8:58	-	9:23	9:33	10:00	10:22	11:00	12:00	1:00	2:00	3:00	3:22
Palo Alto	5:51	6:21	6:57	7:18	7:26	7:36	7:51	8:01	8:18	8:26	8:36	8:51	9:01	9:18	9:26	9:36	10:03	10:25	11:03	12:03	1:03	2:03	3:03	3:25
California Avenue	5:55	6:25	7:01	-	7:30	-	-	-	-	8:30	-	-	-	-	9:30	-	10:07	10:29	11:07	12:07	1:07	2:07	3:07	3:29
San Antonio	5:59	6:29	-	-	7:34	-	-	-	-	8:34	-	-	-	-	9:34	-	10:11	10:33	11:11	12:11	1:11	2:11	3:11	3:33
Mountain View	6:03	6:33	7:07	-	7:38	7:44	7:58	8:09	-	8:38	8:44	8:58	9:09	-	9:38	9:44	10:15	10:37	11:15	12:15	1:15	2:15	3:15	3:37
Sunnyvale	6:08	6:38	-	-	7:43	-	-	-	-	8:43	-	-	-	-	9:43	-	10:20	10:42	11:20	12:20	1:20	2:20	3:20	3:42
Zone 4 Lawrence	6:12	6:42	7:12	-	7:49 ⁺	-	-	8:16	-	8:49 ⁺	-	-	9:16	-	9:49 ⁺	-	10:24	10:46	11:24	12:24	1:24	2:24	3:24	3:46
Santa Clara	6:17	6:47	-	7:34	7:56 ⁺	-	-	-	8:34	8:56 ⁺	-	-	-	9:34	9:56 ⁺	-	10:29	10:51	11:29	12:29	1:29	2:29	3:29	3:51
College Park	-	-	-	-	7:59 ⁺	-	-	-	-	-	-	-	-	-	-	-	-	-	-	-	-	-	-	-
San Jose Diridon	6:26	6:56	7:24	7:43	8:06	7:58	8:13	8:28	8:43	9:05	8:58	9:13	9:28	9:43	10:05	9:58	10:38	11:00	11:38	12:38	1:38	2:38	3:38	4:00
Tamien	-	7:03	-	7:50	8:13	-	-	-	8:50	9:12	-	-	-	9:50	10:12	-	-	11:07	-	-	-	-	-	4:07
Zone 5 Capitol Blossom Hill																								
Zone 6 Morgan Hill San Martin Gilroy	AM																AM			PM				

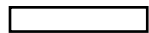

Local

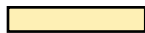

Limited



Baby Bullet



Timed Transfers

- Train bypasses station.

+ Train may leave up to 5 minutes early.

EFFECTIVE OCTOBER 1, 2012

10.12 - RJC

Printer-Friendly Caltrain Schedule

Southbound - Weekday Service

Early Afternoon to Evening - Page 2 of 2



SAN FRANCISCO to SAN JOSE / GILROY - Southbound

WEEKDAY SERVICE

See Page 1 For Morning and Early Afternoon Times

	156	258	360	262	SOUTHBOUND	264	366	268	370	272	274	376	278	380	282	284	386	288	190	192	194	196	198	
Zone 1	3:07	3:37	4:09	4:19	San Francisco	4:27	4:33	4:56	5:14	5:20	5:27	5:33	5:56	6:14	6:20	6:27	6:33	6:56	7:30	8:40	9:40	10:40	12:01	
	3:12	-	-	-	22 nd Street	4:32	-	-	-	-	5:32	-	-	-	-	6:32	-	-	7:35	8:45	9:45	10:45	12:06	
	3:17	-	-	-	Bayshore	4:40	-	-	-	-	5:40	-	-	-	-	6:40	-	-	7:40	8:50	9:50	10:50	12:11	
	3:23	-	-	-	So. San Francisco	4:48	-	5:08	-	-	5:48	-	6:08	-	-	6:48	-	7:08	7:46	8:56	9:56	10:56	12:17	
	3:27	3:51	-	4:33	San Bruno	4:52	-	-	-	5:34	5:52	-	-	-	6:34	6:52	-	-	7:50	9:00	10:00	11:00	12:21	
Zone 2	3:31	3:55	4:25	-	Millbrae	4:56	4:49	5:14	5:30	-	5:56	5:49	6:14	6:30	-	6:56	6:49	7:14	7:54	9:04	10:04	11:04	12:25	
	3:35	3:59	-	4:38	Burlingame	5:00	-	-	-	5:39	6:00	-	-	-	6:39	7:00	-	-	7:58	9:08	10:08	11:08	12:29	
	3:38	4:02	-	4:42	San Mateo	5:04	4:57	-	-	5:43	6:04	5:57	-	-	6:43	7:04	6:57	-	8:01	9:11	10:11	11:11	12:32	
	3:41	-	-	-	Hayward Park	5:07	-	-	-	-	6:07	-	-	-	-	7:07	-	-	-	8:04	9:14	10:14	11:14	12:35
	3:44	4:06	4:33	4:47	Hillsdale	5:11	-	5:22	5:38	5:48	6:11	-	6:22	6:38	6:48	7:11	-	7:22	8:07	9:17	10:17	11:17	12:38	
	3:47	4:09	-	-	Belmont	5:14	-	-	-	-	6:14	-	-	-	-	7:14	-	-	-	8:10	9:20	10:20	11:20	12:41
	3:50	4:12	-	4:51	San Carlos	5:18	-	-	-	5:52	6:18	-	-	-	6:52	7:18	-	-	-	8:13	9:23	10:23	11:23	12:44
	3:55	4:17	-	-	Redwood City	5:22	5:06	5:28	-	-	6:22	6:06	6:28	-	-	7:22	7:06	7:28	-	8:18	9:28	10:28	11:28	12:49
Zone 3	4:00	4:22	-	-	Menlo Park	5:28	-	5:34	-	-	6:28	-	6:34	-	-	7:28	-	7:34	8:23	9:33	10:33	11:33	12:54	
	4:03	4:25	4:44	5:01	Palo Alto	-	5:12	5:38	5:49	6:02	-	6:12	6:38	6:49	7:02	-	7:12	7:38	8:26	9:36	10:36	11:36	12:57	
	4:07	4:29	-	5:05	California Avenue	-	-	5:42	-	6:06	-	-	6:42	-	7:06	-	-	7:42	8:30	9:40	10:40	11:40	1:01	
	4:11	4:33	-	-	San Antonio	-	-	5:46	-	-	-	-	6:46	-	-	-	-	7:46	8:34	9:44	10:44	11:44	1:05	
	4:15	4:37	4:51	5:11	Mountain View	5:36	-	5:50	5:56	6:12	6:36	-	6:50	6:56	7:12	7:36	-	7:50	8:38	9:48	10:48	11:48	1:09	
	4:20	4:42	-	5:16	Sunnyvale	5:41	5:21	5:55	-	6:17	6:41	6:21	6:55	-	7:17	7:41	7:21	7:55	8:43	9:53	10:53	11:53	1:14	
Zone 4	4:24	4:46	-	-	Lawrence	-	-	6:01 ⁺	-	-	6:45	-	7:01 ⁺	-	-	-	-	7:59	8:47	9:57	10:57	11:57	1:18	
	4:29	4:51	-	-	Santa Clara	5:49	-	6:08 ⁺	-	-	6:50	-	7:08 ⁺	-	-	7:49	-	8:04	8:52	10:02	11:02	12:02	1:23	
	4:32	-	-	-	College Park	-	-	-	-	-	-	-	-	-	-	-	-	-	-	-	-	-	-	
	4:39	5:00	5:06	5:27	San Jose Diridon	5:57	5:32	6:16	6:11	6:28	6:58	6:32	7:16	7:11	7:28	7:57	7:32	8:12	9:01	10:11	11:11	12:11	1:32	
	4:45	5:07	-	-	Tamien	-	5:39	6:22	-	-	7:04	6:39	7:23	-	-	-	7:39	8:19	-	10:18	11:18	-	-	
Zone 5	4:52	-	-	-	Capitol	-	-	6:29	-	-	7:11	-	-	-	-	-	-	-	-	-	-	-	-	
	4:58	-	-	-	Blossom Hill	-	-	6:35	-	-	7:17	-	-	-	-	-	-	-	-	-	-	-	-	
Zone 6	5:11	-	-	-	Morgan Hill	-	-	6:48	-	-	7:30	-	-	-	-	-	-	-	-	-	-	-	-	
	5:17	PM	-	-	San Martin	-	-	6:54	-	-	7:36	-	-	-	-	-	-	-	-	PM	AM	-	-	
	5:30	-	-	-	Gilroy	-	-	7:07	-	-	7:49	-	-	-	-	-	-	-	-	-	-	-	-	

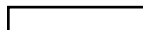

Local

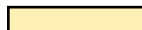

Limited



Baby Bullet



Timed Transfers

- Train bypasses station.

+ Train may leave up to 5 minutes early.

EFFECTIVE OCTOBER 1, 2012

10.12 - RJC



SATURDAY / SUNDAY - Northbound

SAN JOSE to SAN FRANCISCO

		SAT ONLY																SAT ONLY							
Train No.		421	423	425	427	801	429	431	433	435	437	439	441	803	443	445	447	449	*451						
		<div style="display: flex; justify-content: space-between;"> AM PM </div>																							
Shuttle Bus		-																							
Departs: Tamien		-																							
Arrives SJ Diridon		-																							
Mile Post		7:00	7:05	7:10	7:14	7:19	7:23	7:27	7:31	7:34	7:37	7:41	7:45	7:48	7:51	7:54	7:57	8:00	8:03	8:08	8:12	8:17	8:23	8:28	8:36
47.5	San Jose Diridon	8:00	8:05	8:10	8:14	8:19	8:23	8:27	8:31	8:34	8:37	8:41	8:45	8:48	8:51	8:54	8:57	9:00	9:03	9:08	9:12	9:17	9:23	9:28	9:36
44.7	Santa Clara	9:00	9:05	9:10	9:14	9:19	9:23	9:27	9:31	9:34	9:37	9:41	9:45	9:48	9:51	9:54	9:57	10:00	10:03	10:08	10:12	10:17	10:23	10:28	10:36
40.8	Lawrence	10:00	10:05	10:10	10:14	10:19	10:23	10:27	10:31	10:34	10:37	10:41	10:45	10:48	10:51	10:54	10:57	11:00	11:03	11:08	11:12	11:17	11:23	11:28	11:36
38.8	Sunnyvale	11:00	11:05	11:10	11:14	11:19	11:23	11:27	11:31	11:34	11:37	11:41	11:45	11:48	11:51	11:54	11:57	12:00	12:03	12:08	12:12	12:17	12:23	12:28	12:36
36.1	Mountain View	12:00	12:05	12:10	12:14	12:19	12:23	12:27	12:31	12:34	12:37	12:41	12:45	12:48	12:51	12:54	12:57	1:00	1:03	1:08	1:12	1:17	1:23	1:28	1:36
34.1	San Antonio	1:00	1:05	1:10	1:14	1:19	1:23	1:27	1:31	1:34	1:37	1:41	1:45	1:48	1:51	1:54	1:57	2:00	2:03	2:08	2:12	2:17	2:23	2:28	2:36
31.8	California Avenue	2:00	2:05	2:10	2:14	2:19	2:23	2:27	2:31	2:34	2:37	2:41	2:45	2:48	2:51	2:54	2:57	3:00	3:03	3:08	3:12	3:17	3:23	3:28	3:36
30.1	Palo Alto	3:00	3:05	3:10	3:14	3:19	3:23	3:27	3:31	3:34	3:37	3:41	3:45	3:48	3:51	3:54	3:57	4:00	4:03	4:08	4:12	4:17	4:23	4:28	4:36
28.9	Menlo Park	4:00	4:05	4:10	4:14	4:19	4:23	4:27	4:31	4:34	4:37	4:41	4:45	4:48	4:51	4:54	4:57	5:00	5:03	5:08	5:12	5:17	5:23	5:28	5:36
27.8	Atherton	5:00	5:05	5:10	5:14	5:19	5:23	5:27	5:31	5:34	5:37	5:41	5:45	5:48	5:51	5:54	5:57	6:00	6:03	6:08	6:12	6:17	6:23	6:28	6:36
25.4	Redwood City	6:00	6:05	6:10	6:14	6:19	6:23	6:27	6:31	6:34	6:37	6:41	6:45	6:48	6:51	6:54	6:57	7:00	7:03	7:08	7:12	7:17	7:23	7:28	7:36
23.2	San Carlos	7:00	7:05	7:10	7:14	7:19	7:23	7:27	7:31	7:34	7:37	7:41	7:45	7:48	7:51	7:54	7:57	8:00	8:03	8:08	8:12	8:17	8:23	8:28	8:36
21.9	Belmont	8:00	8:05	8:10	8:14	8:19	8:23	8:27	8:31	8:34	8:37	8:41	8:45	8:48	8:51	8:54	8:57	9:00	9:03	9:08	9:12	9:17	9:23	9:28	9:36
20.3	Hillsdale	9:00	9:05	9:10	9:14	9:19	9:23	9:27	9:31	9:34	9:37	9:41	9:45	9:48	9:51	9:54	9:57	10:00	10:03	10:08	10:12	10:17	10:23	10:28	10:36
19.1	Hayward Park	10:00	10:05	10:10	10:14	10:19	10:23	10:27	10:31	10:34	10:37	10:41	10:45	10:48	10:51	10:54	10:57	11:00	11:03	11:08	11:12	11:17	11:23	11:28	11:36
17.9	San Mateo	11:00	11:05	11:10	11:14	11:19	11:23	11:27	11:31	11:34	11:37	11:41	11:45	11:48	11:51	11:54	11:57	12:00	12:03	12:08	12:12	12:17	12:23	12:28	12:36
16.3	Burlingame	12:00	12:05	12:10	12:14	12:19	12:23	12:27	12:31	12:34	12:37	12:41	12:45	12:48	12:51	12:54	12:57	1:00	1:03	1:08	1:12	1:17	1:23	1:28	1:36
15.2	Broadway	1:00	1:05	1:10	1:14	1:19	1:23	1:27	1:31	1:34	1:37	1:41	1:45	1:48	1:51	1:54	1:57	2:00	2:03	2:08	2:12	2:17	2:23	2:28	2:36
13.7	Millbrae	2:00	2:05	2:10	2:14	2:19	2:23	2:27	2:31	2:34	2:37	2:41	2:45	2:48	2:51	2:54	2:57	3:00	3:03	3:08	3:12	3:17	3:23	3:28	3:36
11.6	San Bruno	3:00	3:05	3:10	3:14	3:19	3:23	3:27	3:31	3:34	3:37	3:41	3:45	3:48	3:51	3:54	3:57	4:00	4:03	4:08	4:12	4:17	4:23	4:28	4:36
9.3	So. San Francisco	4:00	4:05	4:10	4:14	4:19	4:23	4:27	4:31	4:34	4:37	4:41	4:45	4:48	4:51	4:54	4:57	5:00	5:03	5:08	5:12	5:17	5:23	5:28	5:36
5.2	Bayshore	5:00	5:05	5:10	5:14	5:19	5:23	5:27	5:31	5:34	5:37	5:41	5:45	5:48	5:51	5:54	5:57	6:00	6:03	6:08	6:12	6:17	6:23	6:28	6:36
1.9	22nd Street	6:00	6:05	6:10	6:14	6:19	6:23	6:27	6:31	6:34	6:37	6:41	6:45	6:48	6:51	6:54	6:57	7:00	7:03	7:08	7:12	7:17	7:23	7:28	7:36
0.2	San Francisco	7:00	7:05	7:10	7:14	7:19	7:23	7:27	7:31	7:34	7:37	7:41	7:45	7:48	7:51	7:54	7:57	8:00	8:03	8:08	8:12	8:17	8:23	8:28	8:36

Weekend Express Pilot Project

* Train departure may be delayed up to 15 minutes.

On weekends, a shuttle bus connects the Tamien and Diridon stations. Caltrain fare policies apply. Timetable subject to change without notice.



SATURDAY / SUNDAY - Southbound

SAN FRANCISCO to SAN JOSE

		SATURDAY ONLY																	
Train No.		422	424	426	428	802	430	432	434	436	438	440	442	804	444	446	448	450	454
0.2	San Francisco	8:15	9:15	10:15	11:15	11:59	12:15	1:15	2:15	3:15	4:15	5:15	6:15	6:59	7:15	8:15	9:15	10:15	12:01
1.9	22nd Street	8:20	9:20	10:20	11:20	-	12:20	1:20	2:20	3:20	4:20	5:20	6:20	-	7:20	8:20	9:20	10:20	12:06
5.2	Bayshore	8:25	9:25	10:25	11:25	-	12:25	1:25	2:25	3:25	4:25	5:25	6:25	-	7:25	8:25	9:25	10:25	12:11
9.3	So. San Francisco	8:31	9:31	10:31	11:31	-	12:31	1:31	2:31	3:31	4:31	5:31	6:31	-	7:31	8:31	9:31	10:31	12:17
11.6	San Bruno	8:35	9:35	10:35	11:35	-	12:35	1:35	2:35	3:35	4:35	5:35	6:35	-	7:35	8:35	9:35	10:35	12:21
13.7	Millbrae	8:39	9:39	10:39	11:39	12:15	12:39	1:39	2:39	3:39	4:39	5:39	6:39	7:15	7:39	8:39	9:39	10:39	12:25
15.2	Broadway	8:43	9:43	10:43	11:43	-	12:43	1:43	2:43	3:43	4:43	5:43	6:43	-	7:43	8:43	9:43	10:43	12:29
16.3	Burlingame	8:45	9:45	10:45	11:45	-	12:45	1:45	2:45	3:45	4:45	5:45	6:45	-	7:45	8:45	9:45	10:45	12:31
17.9	San Mateo	8:49	9:49	10:49	11:49	12:21	12:49	1:49	2:49	3:49	4:49	5:49	6:49	7:21	7:49	8:49	9:49	10:49	12:35
19.1	Hayward Park	8:52	9:52	10:52	11:52	-	12:52	1:52	2:52	3:52	4:52	5:52	6:52	-	7:52	8:52	9:52	10:52	12:38
20.3	Hillsdale	8:55	9:55	10:55	11:55	12:25	12:55	1:55	2:55	3:55	4:55	5:55	6:55	7:25	7:55	8:55	9:55	10:55	12:41
21.9	Belmont	8:58	9:58	10:58	11:58	-	12:58	1:58	2:58	3:58	4:58	5:58	6:58	-	7:58	8:58	9:58	10:58	12:44
23.2	San Carlos	9:01	10:01	11:01	12:01	-	1:01	2:01	3:01	4:01	5:01	6:01	7:01	-	8:01	9:01	10:01	11:01	12:47
25.4	Redwood City	9:07	10:07	11:07	12:07	12:33	1:07	2:07	3:07	4:07	5:07	6:07	7:07	7:33	8:07	9:07	10:07	11:07	12:53
27.8	Atherton	9:11	10:11	11:11	12:11	-	1:11	2:11	3:11	4:11	5:11	6:11	7:11	-	8:11	9:11	10:11	11:11	12:57
28.9	Menlo Park	9:14	10:14	11:14	12:14	-	1:14	2:14	3:14	4:14	5:14	6:14	7:14	-	8:14	9:14	10:14	11:14	1:00
30.1	Palo Alto	9:17	10:17	11:17	12:17	12:39	1:17	2:17	3:17	4:17	5:17	6:17	7:17	7:39	8:17	9:17	10:17	11:17	1:03
31.8	California Avenue	9:21	10:21	11:21	12:21	-	1:21	2:21	3:21	4:21	5:21	6:21	7:21	-	8:21	9:21	10:21	11:21	1:07
34.1	San Antonio	9:25	10:25	11:25	12:25	-	1:25	2:25	3:25	4:25	5:25	6:25	7:25	-	8:25	9:25	10:25	11:25	1:11
36.1	Mountain View	9:29	10:29	11:29	12:29	12:47	1:29	2:29	3:29	4:29	5:29	6:29	7:29	7:47	8:29	9:29	10:29	11:29	1:15
38.8	Sunnyvale	9:34	10:34	11:34	12:34	12:52	1:34	2:34	3:34	4:34	5:34	6:34	7:34	7:52	8:34	9:34	10:34	11:34	1:20
40.8	Lawrence	9:38	10:38	11:38	12:38	-	1:38	2:38	3:38	4:38	5:38	6:38	7:38	-	8:38	9:38	10:38	11:38	1:24
44.7	Santa Clara																		